

Assembly Instructions

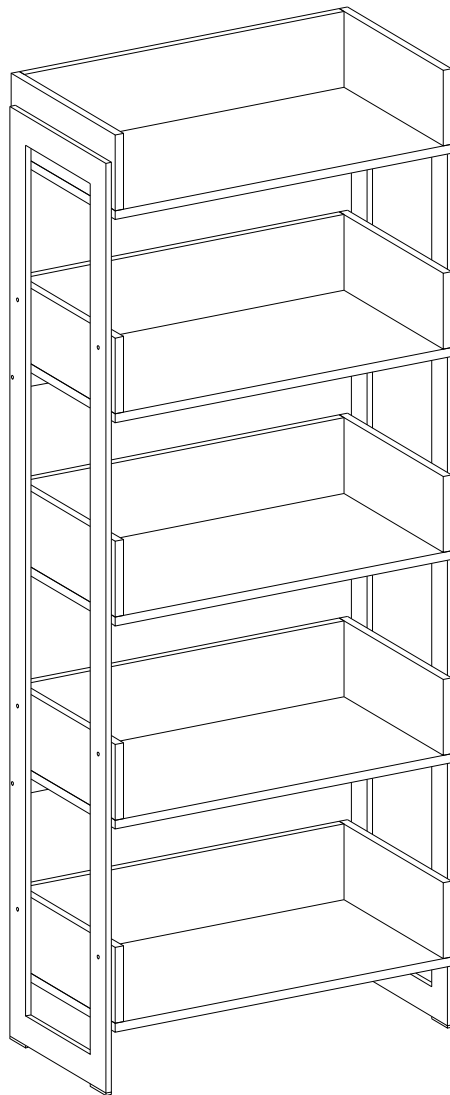

General Assembly Guidelines

- I. Ensure that all parts and hardware are available before beginning assembly.
- II. Follow each step carefully to ensure the proper assembly of this product.
- III. Two people are recommended for ease in the assembly of this product.
- IV. The three main types of hardware used to assemble this product are: wood dowels, screws and bolts.
- V. The provided glue is to secure wood dowels in place. When first inserting dowels, locate the appropriate hole for the dowel, place a small amount of glue in the hole and insert the dowel. Wipe away excess glue immediately.

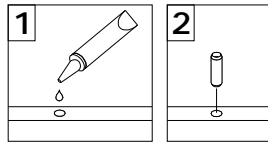

In future assembly steps when dowels are necessary to attach assembly parts together, place a small amount of glue on the end of the dowel before attaching parts together. Wipe away excess glue immediately.

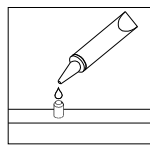

- VI. A Phillips head screwdriver is required for the assembly of this product .

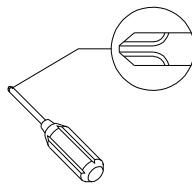

- VII. Power tools should not be used to assemble this product.

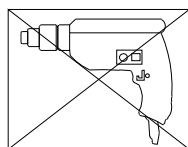





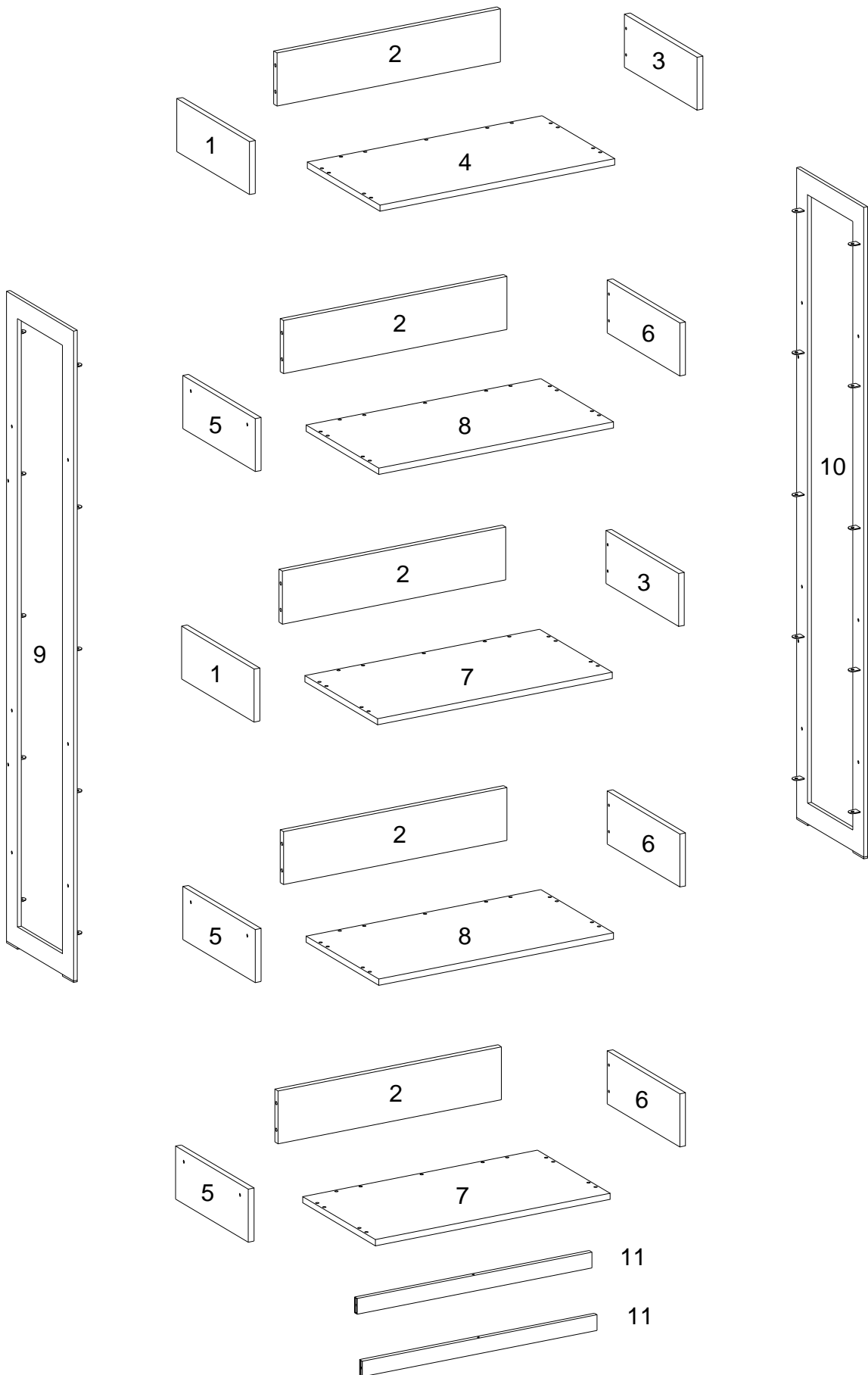



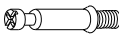

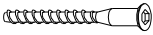

- VIII. Drill may be needed for securing product to wall.

Parts List

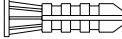

Hardware List

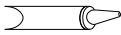
A		Ø8x30mm	Wooden dowel	30	pcs
B		Ø6x35mm	Cam bolt	20	pcs
C		Ø15x11mm	Cam lock	20	pcs
D		Ø30mm	Sticker	20	pcs
E		Ø6x38mm	Screw	35	pcs
F		Ø1/4"x12mm	Bolt	21	pcs
G		Ø1/4"x30mm	Bolt	4	pcs
H		M 4	Hex key	1	pc
J		Ø1/4"x18mm	Bolt	12	pcs
K			Bracket	1	pc
L			Flat washer	1	pc
M		Ø4x30mm	Screw	1	pc
N			Wall anchor	1	pc
P		Ø4x50mm	Screw	2	pcs
Q			Glue tube	1	pc

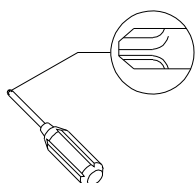

Philips head screwdriver required for assembly
(not included)

*The hardware quantities listed above are required for proper assembly.
Some extra hardware may also have been included.*

Step 1

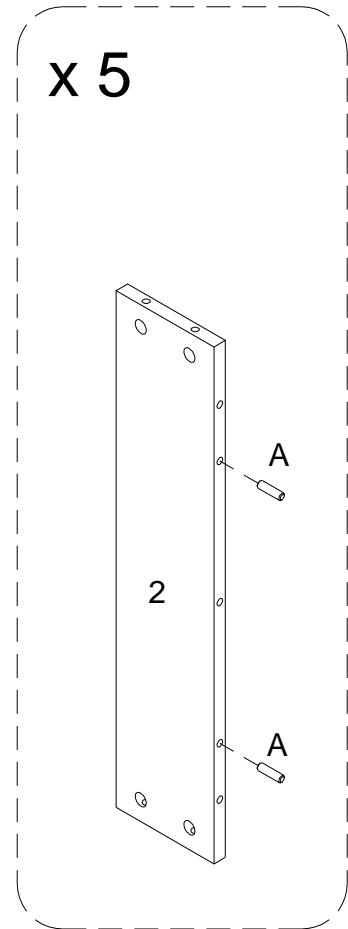
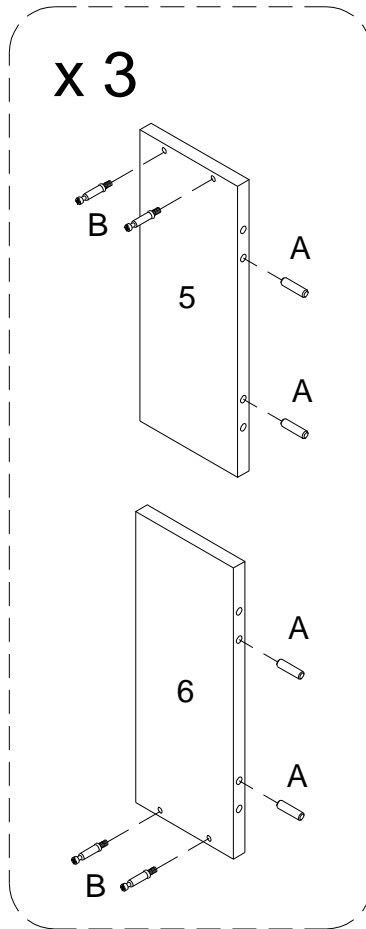
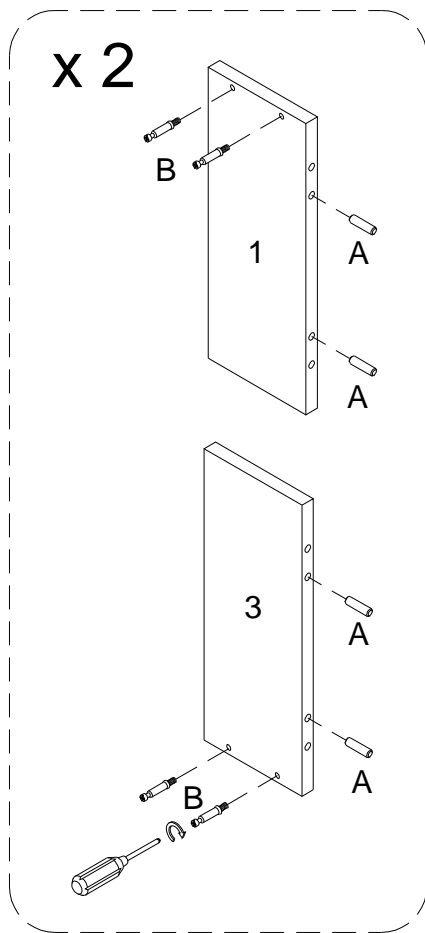

Insert wooden dowel (A) into parts (1,2,3,5,6), then secure cam bolt (B) into parts (1,3,5,6) with Philips head screwdriver as per diagram.

Step 2

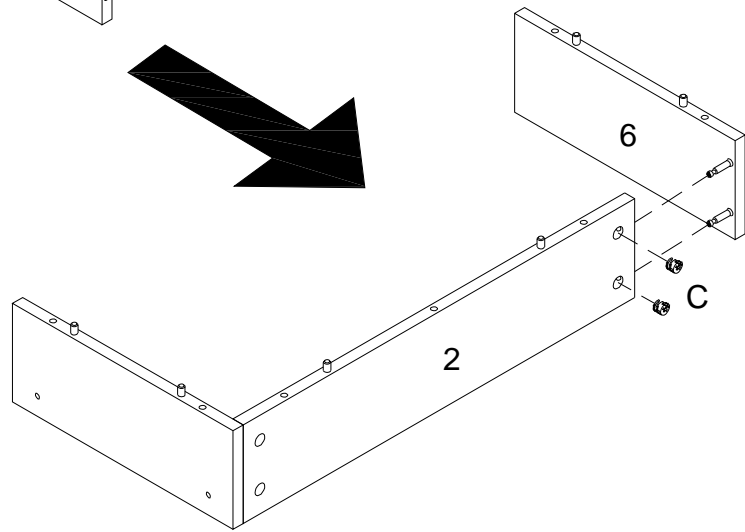
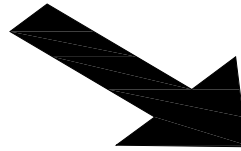
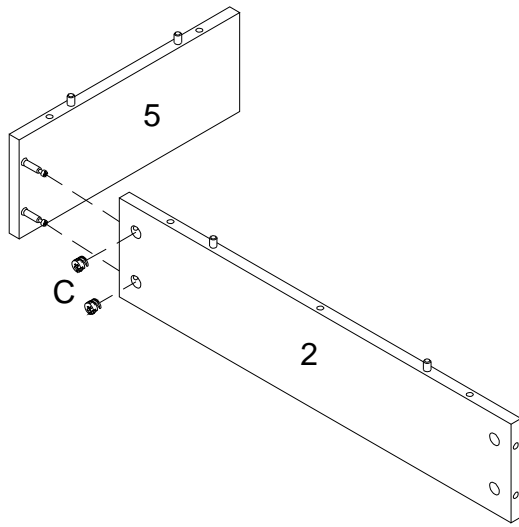
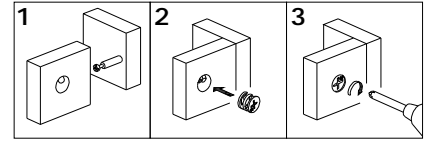

x 3

Using Cam lock(C) secure parts (5,6) to part (2) with Philips head screwdriver as per diagram.

Step 3

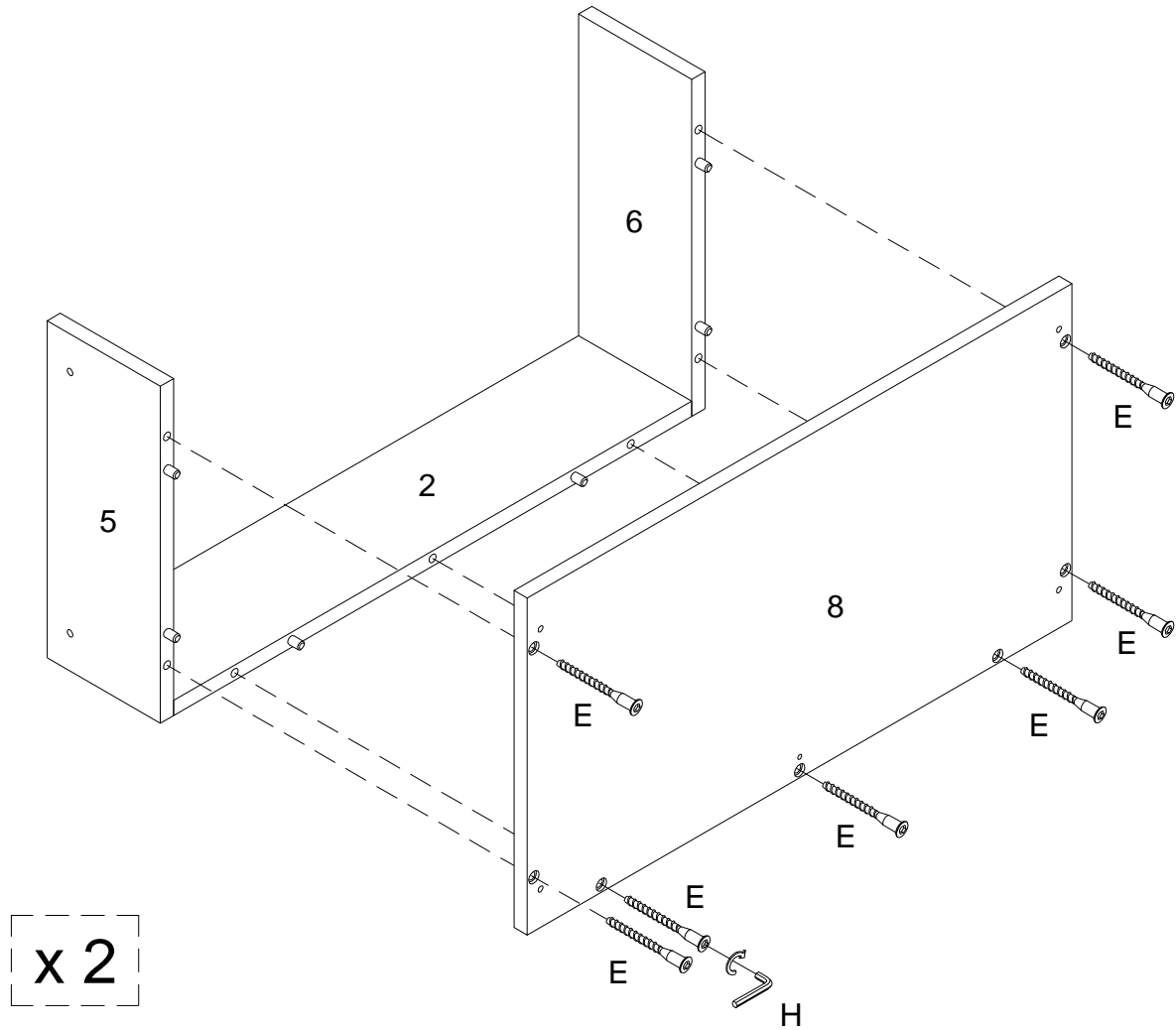

Using Screw (E) attach part (8) into parts (2,5,6) with hex key (H) as per diagram.

Step 4

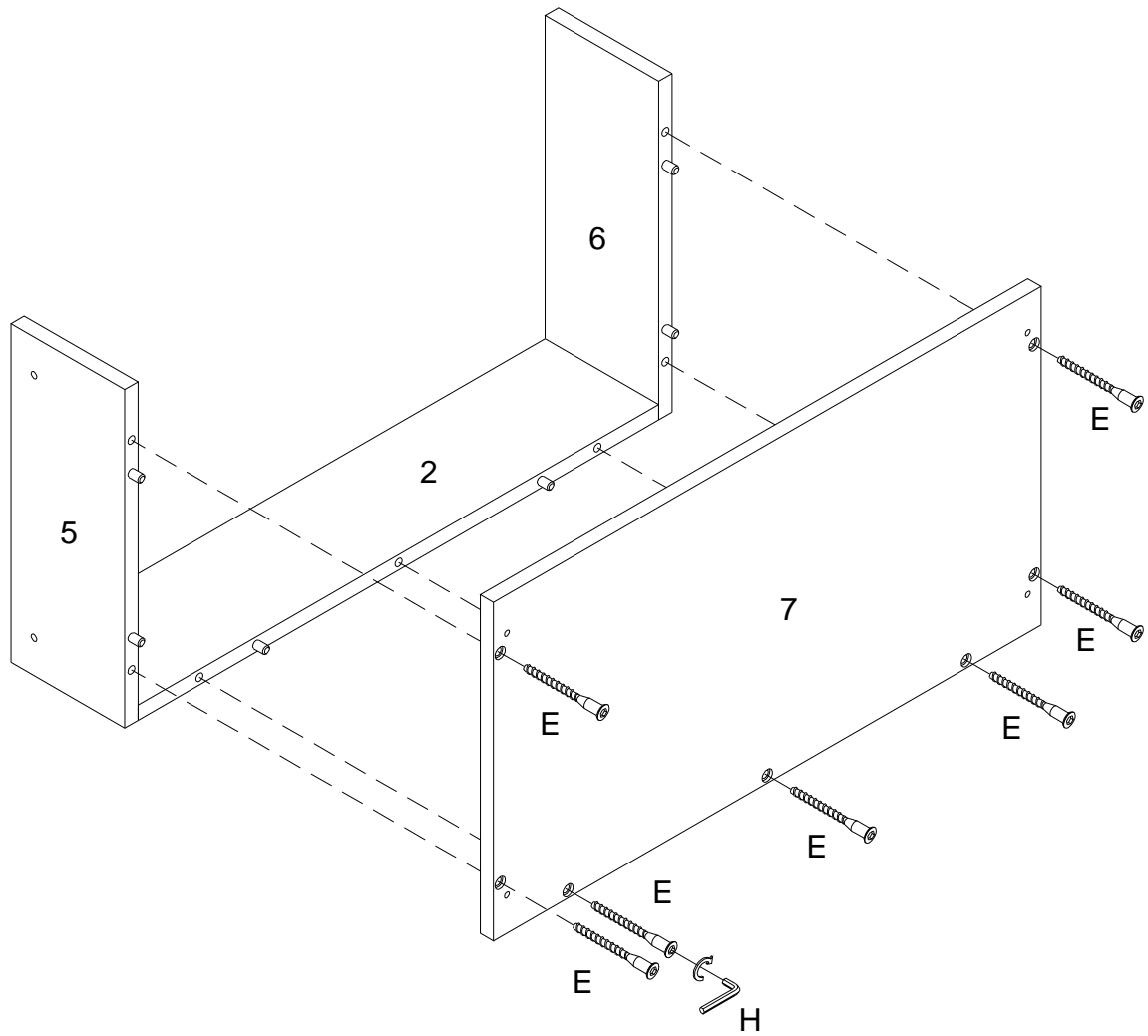

Using Screw (E) attach part (7) into parts (2,5,6) with hex key (H) as per diagram.

Step 5

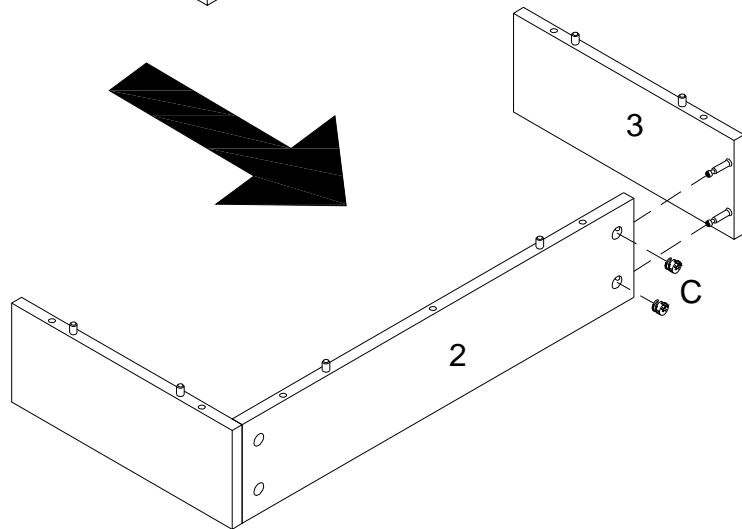
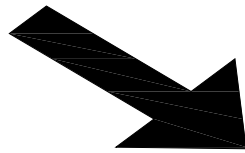
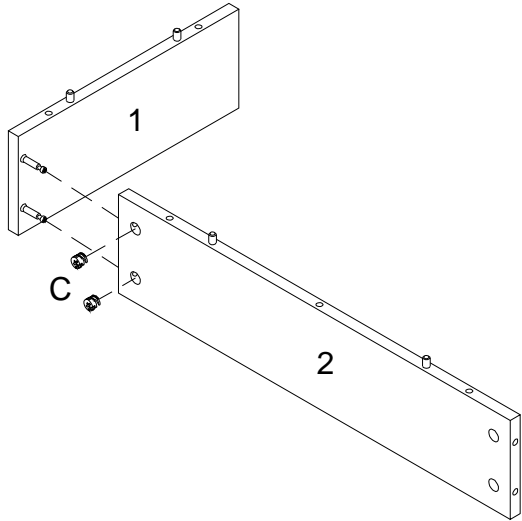
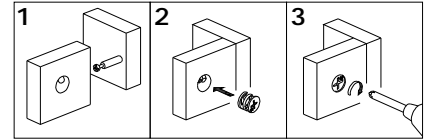

x 2

Using Cam lock(C) secure parts (1,3) to part (2) with Philips head screwdriver as per diagram.

Step 6

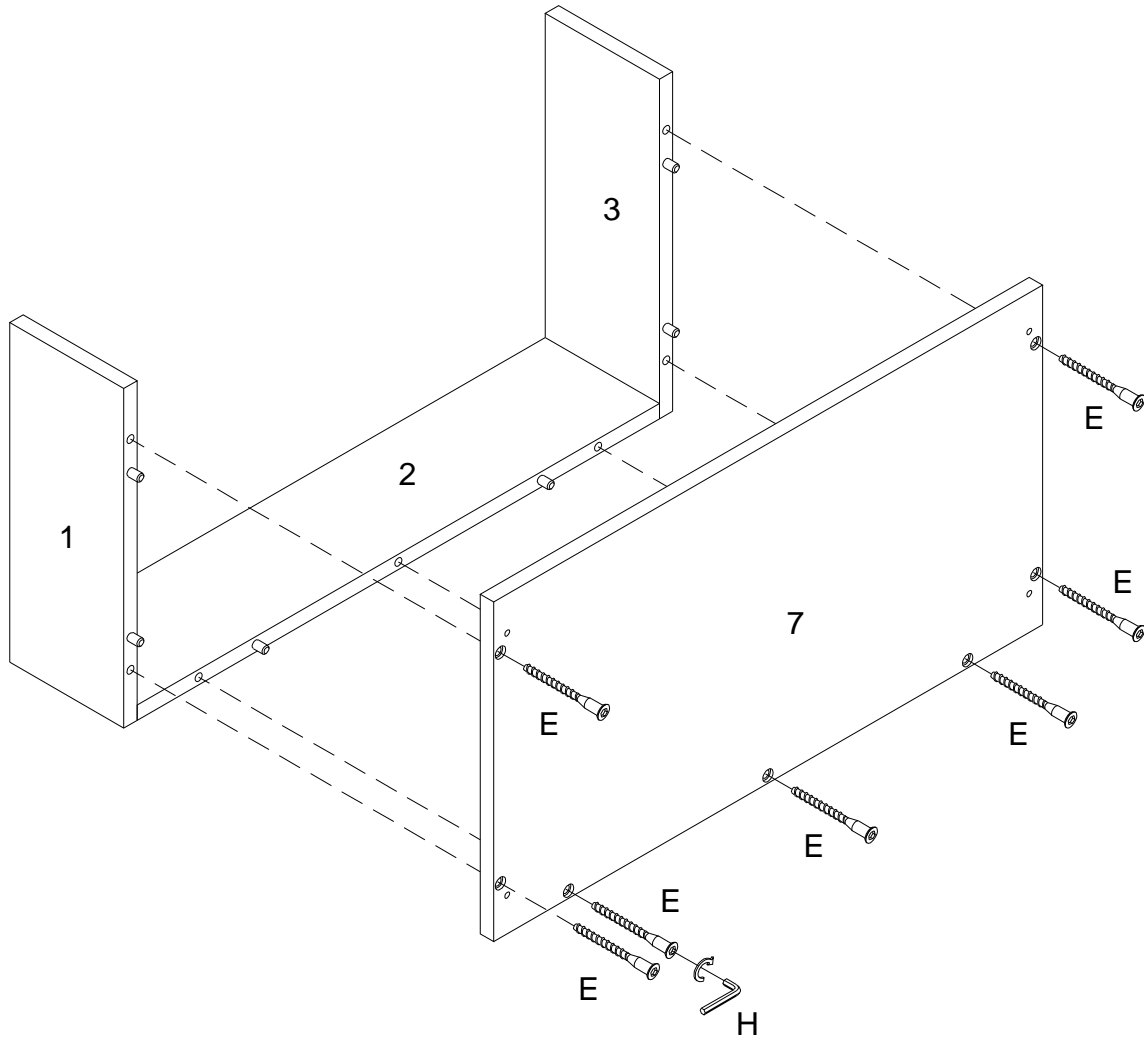

Using Screw (E) attach part (7) into parts (1,2,3) with Hex key (H) as per diagram.

Step 7

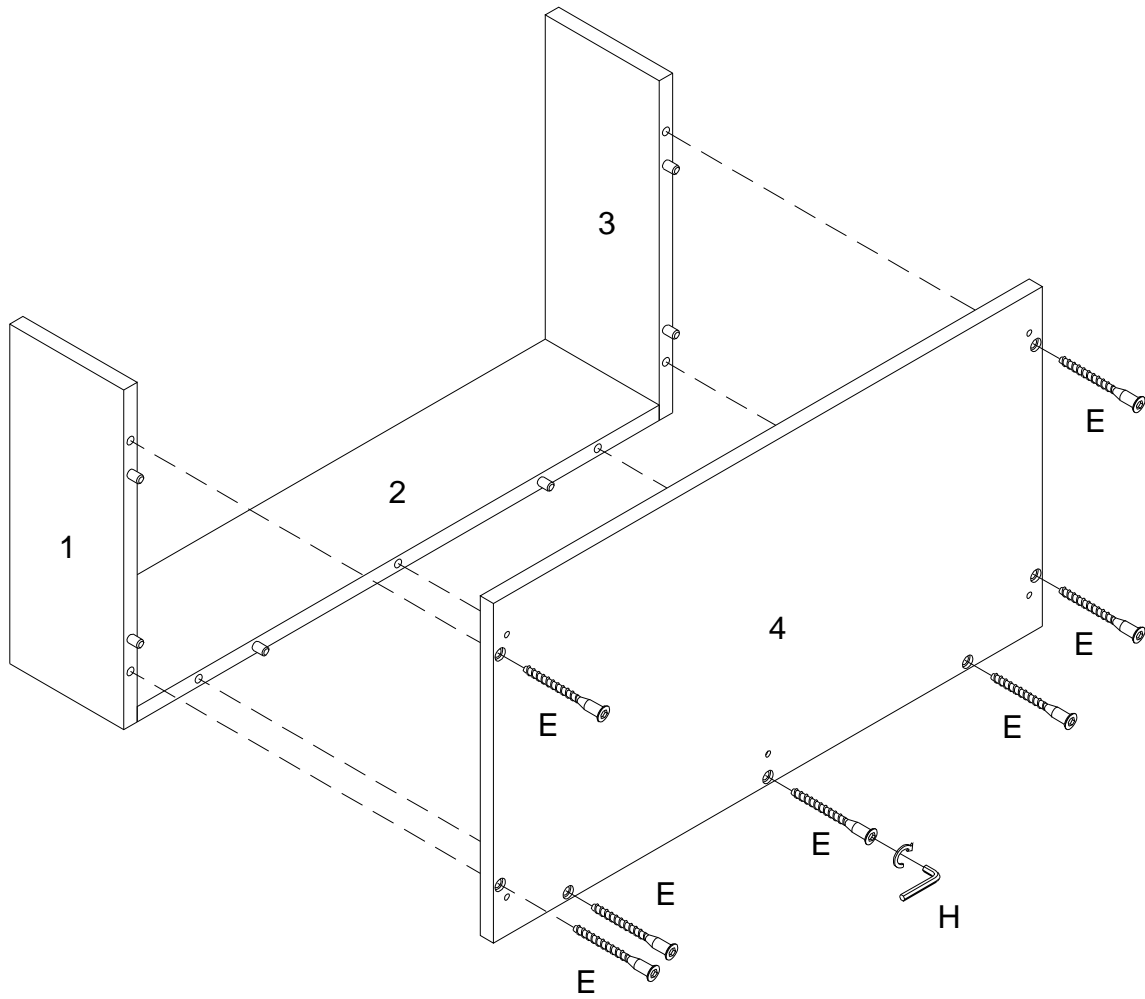

Using Screw (E) attach part (4) into parts (1,2,3) with Hex key (H) as per diagram.

Step 8

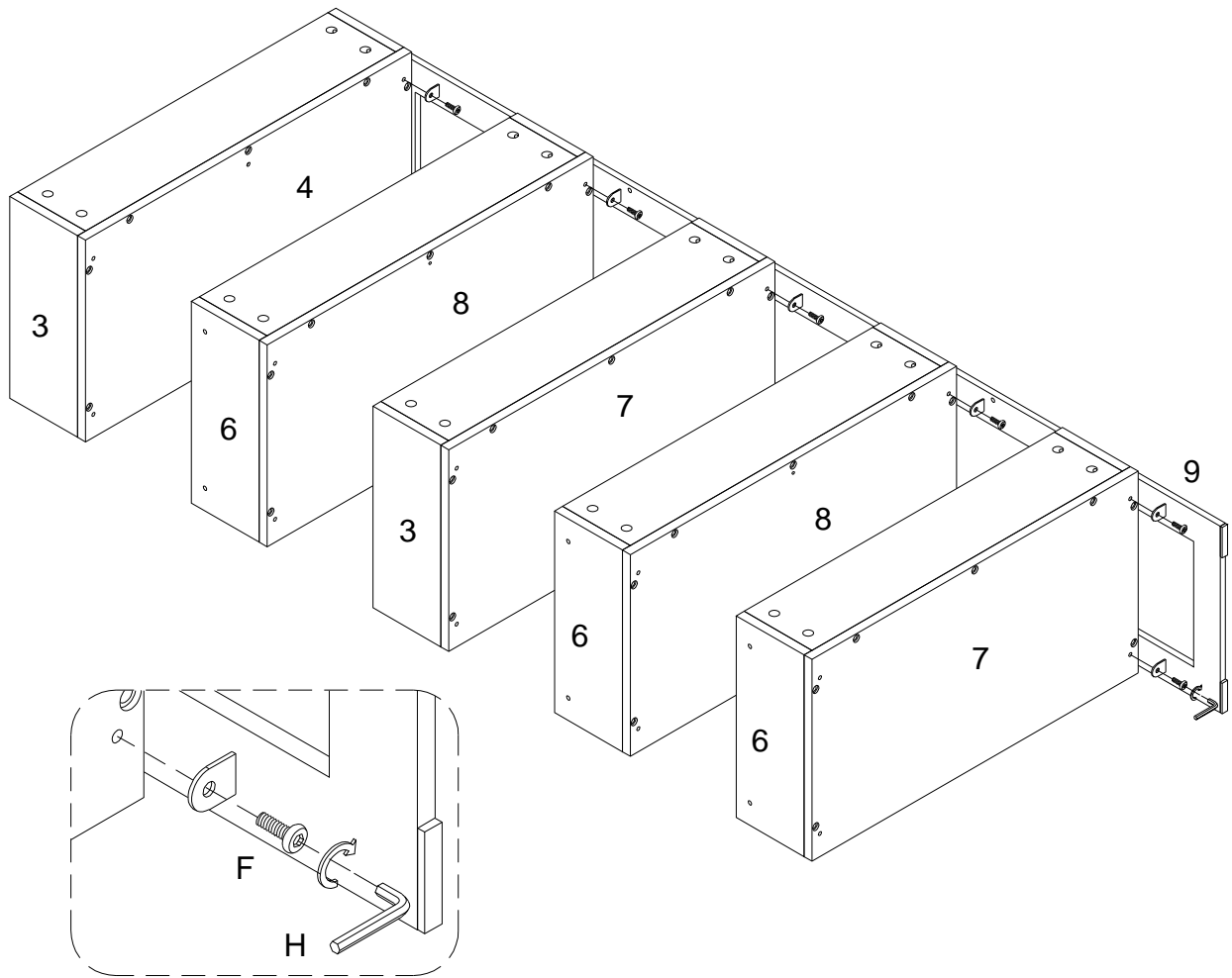

Using Bolt (F) attach part (9) to parts (4,7,8) with Hex key (H) as per diagram.
Note: Do not fully tighten all bolts .

Step 9

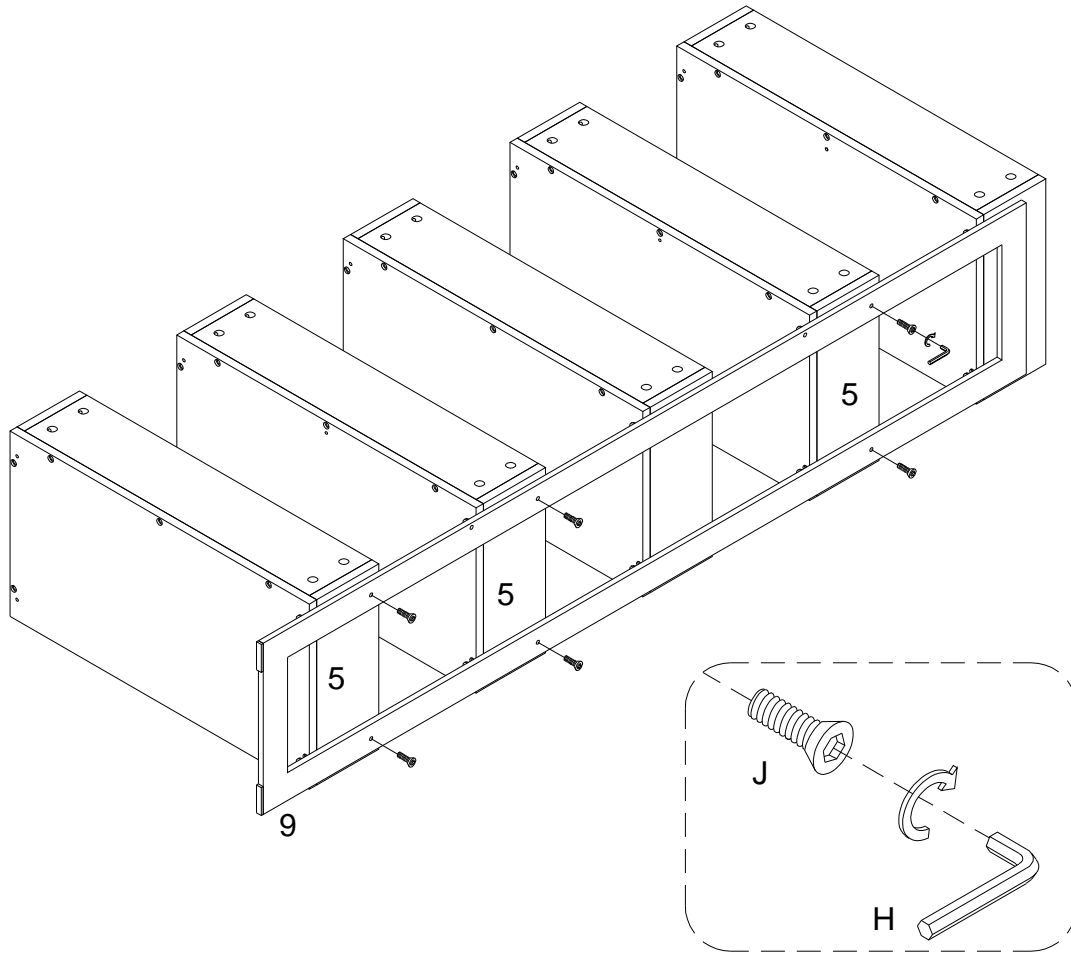

Using Bolt (J) attach part (9) to parts (5) with Hex key (H) as per diagram.

Step 10

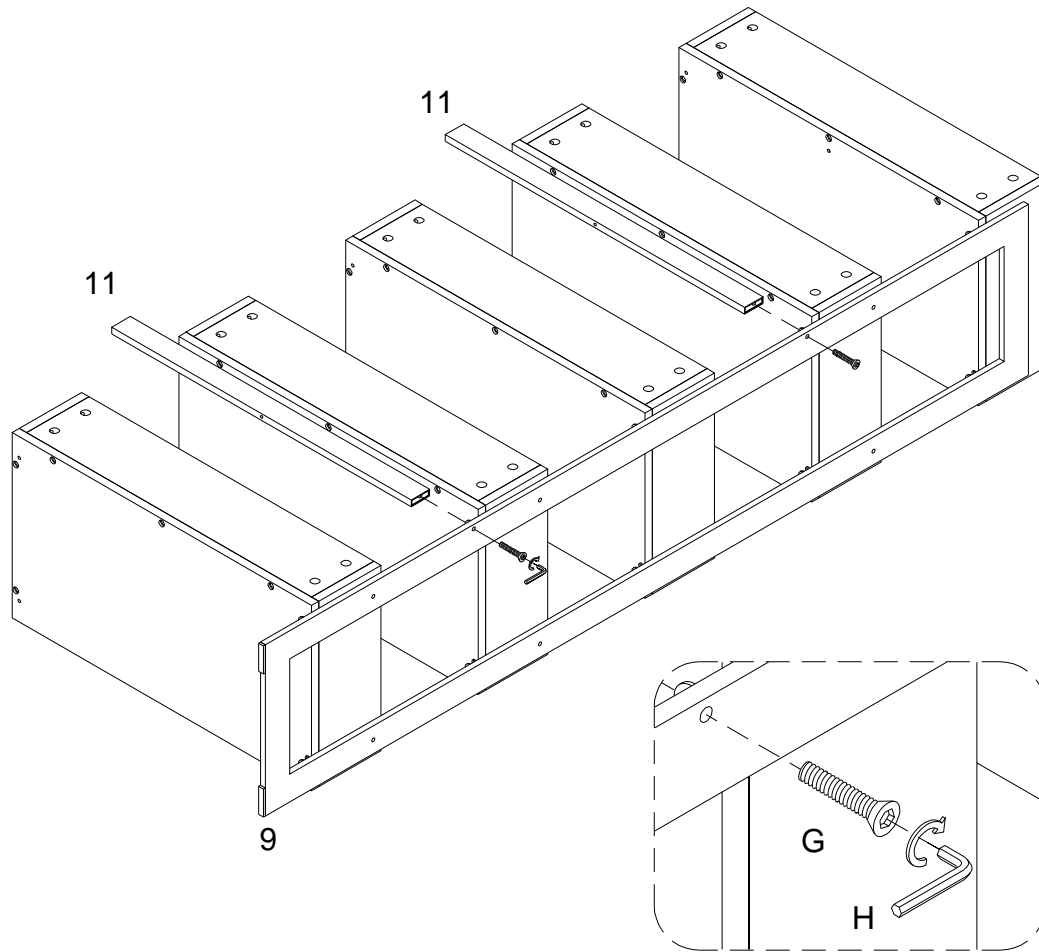

Using Bolt (G) attach part (9) into part (11) with Hex key (H) as per diagram.

Step 11

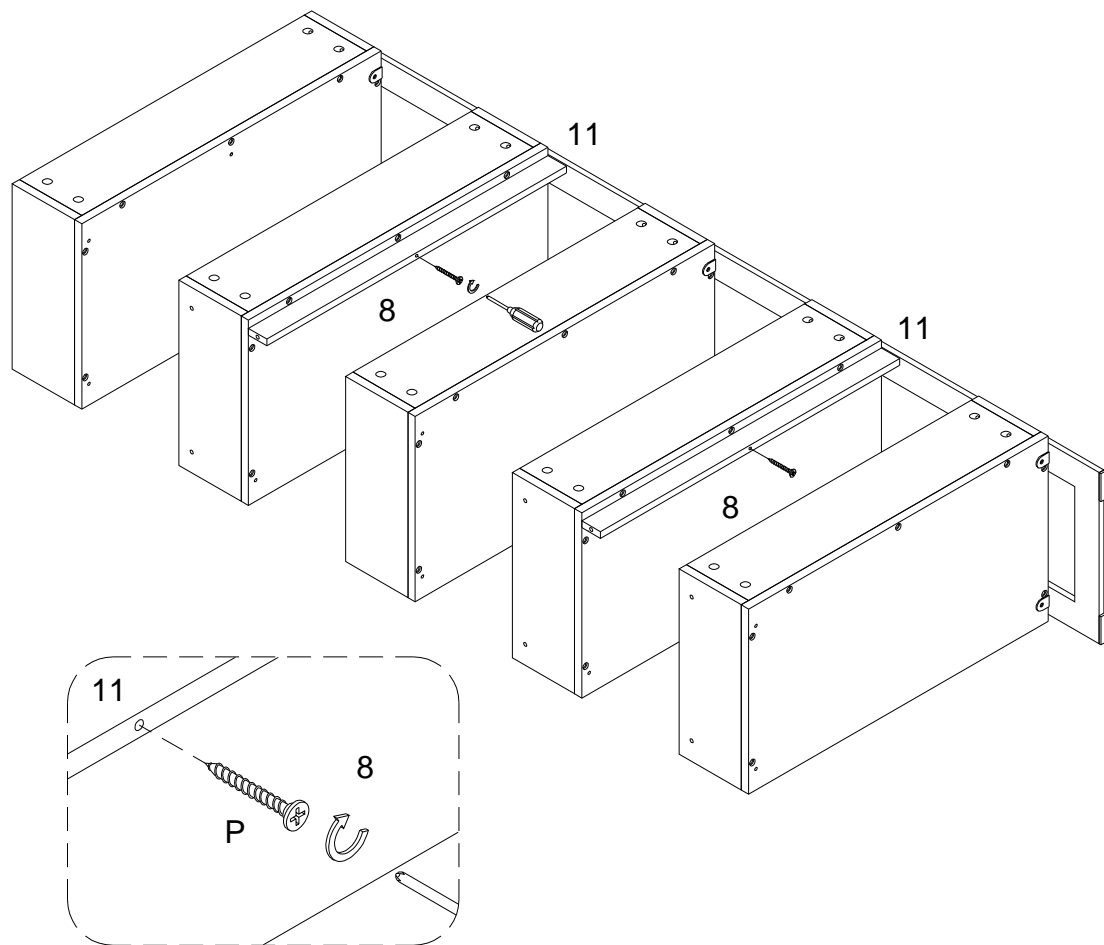

Using Screw (P) attach part (8) into part (11) with Philips head screwdriver as per diagram.

Step 12

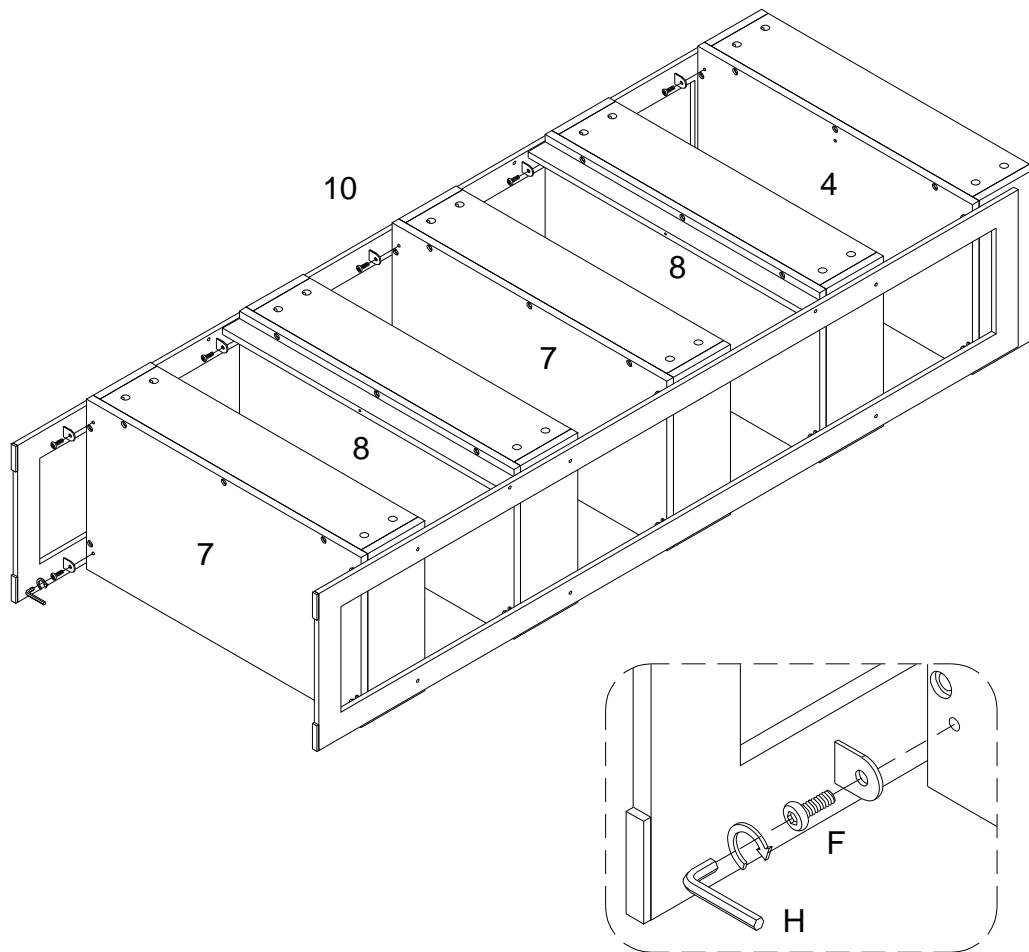

Using Bolt (F) attach part (10) into parts (4,7,8) with Hex key (H) as per diagram.

Step 13

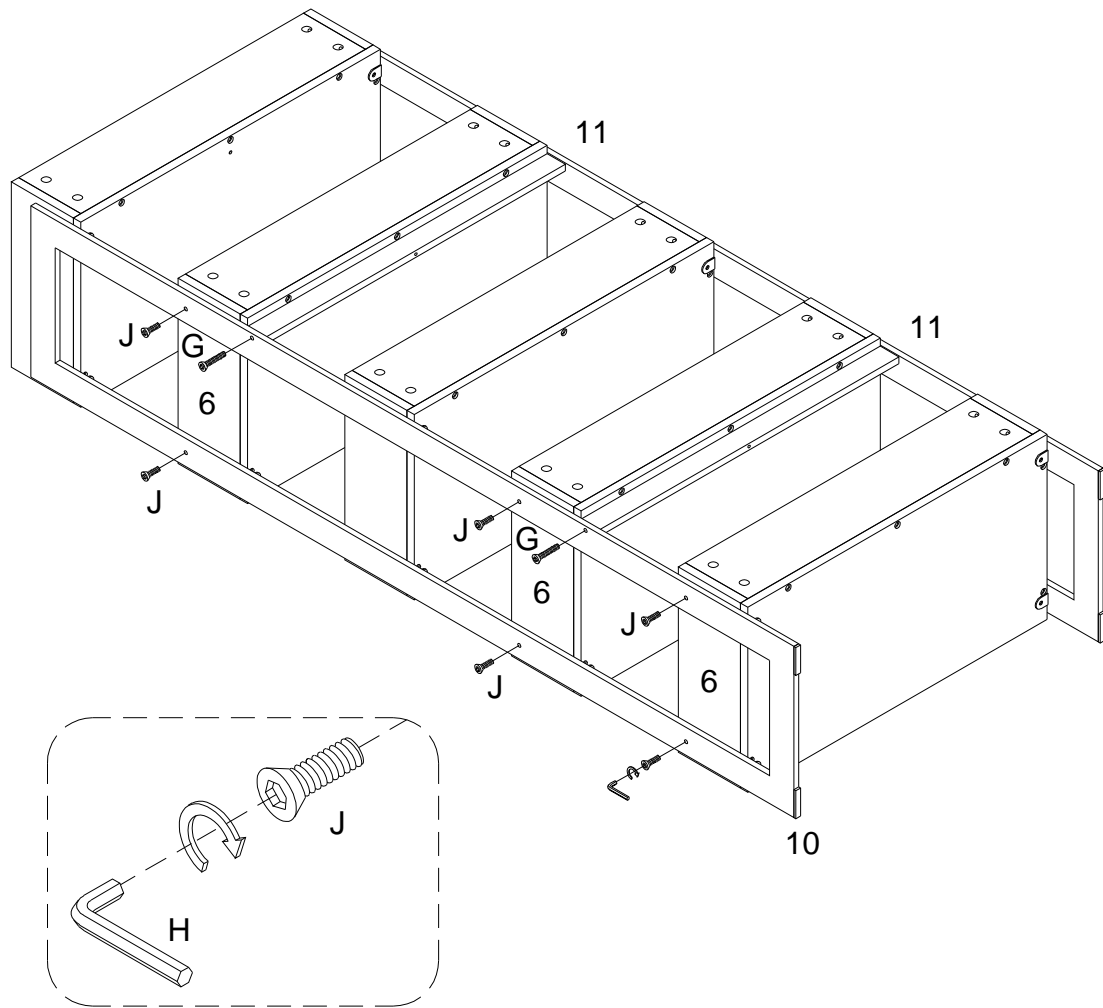

Using Bolt (J) attach part (10) into part (6) , then using Bolt (G) attach part (10) to part (11) with Hex key (H) as per diagram.

Note: Fully tighten all bolts.

Step 14

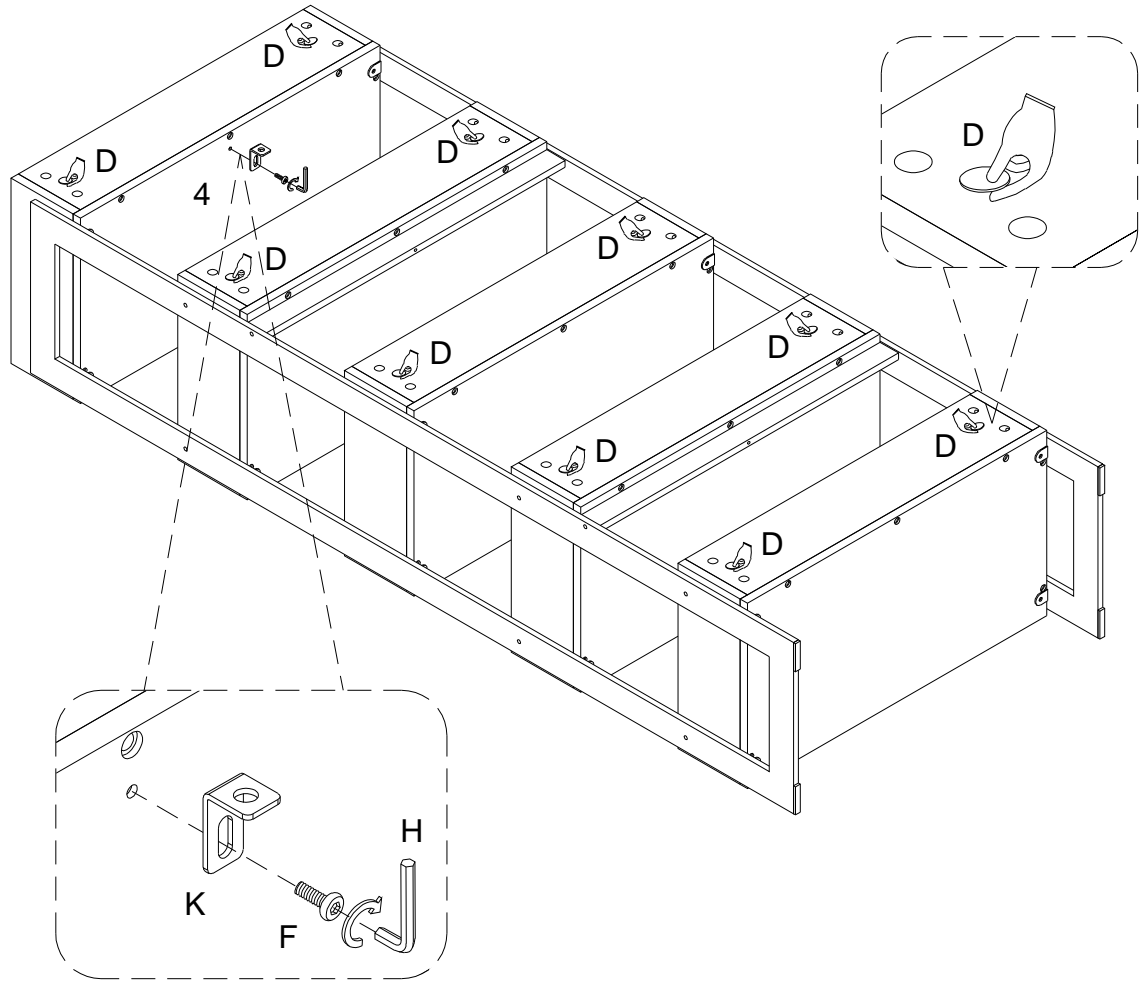

Place sticker (D) cover the holes ,then using Bolt (F) attach Bracket (K) to part (4) with Hex key (H) as per diagram.

Step 15

WARNING

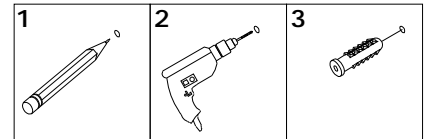

Serious or fatal injuries can occur from furniture tipping over. To prevent the furniture from tipping over we recommend that it is permanently fixed to the wall. Wall anchor and hardware are included with this product. Please make sure hardware is suitable for your walls before installing, as different wall materials may require different types of anchors.

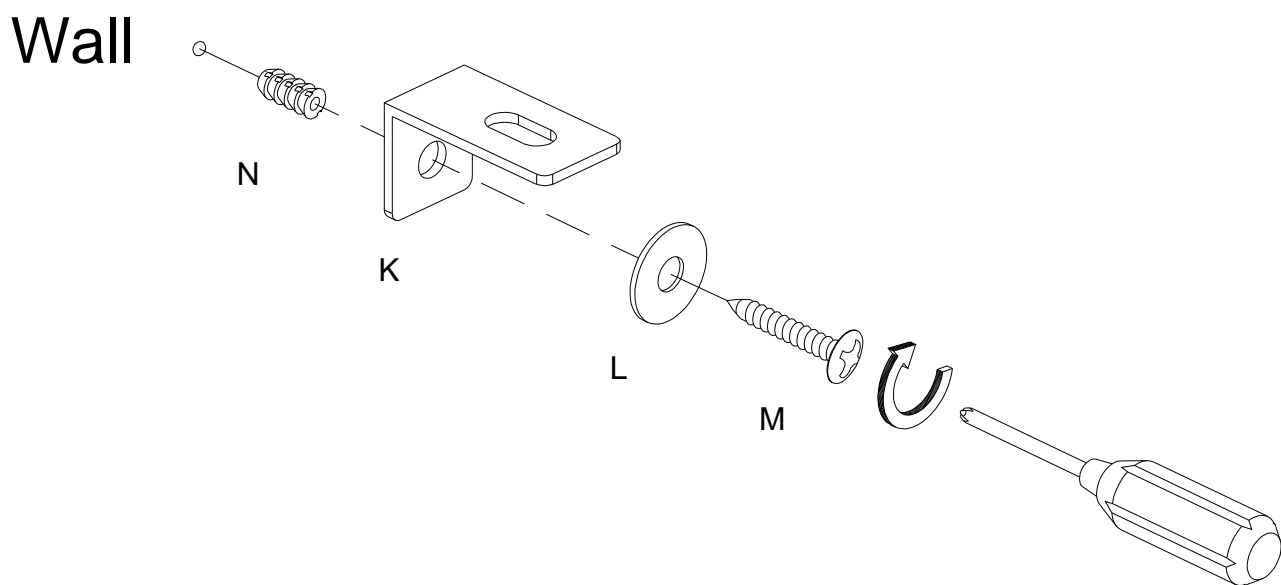

Using Screw (M) attach Flat washer (L) ,Bracket (K) and wall anchor (N) to Wall with Philips head screwdriver as per diagram.

Step 16

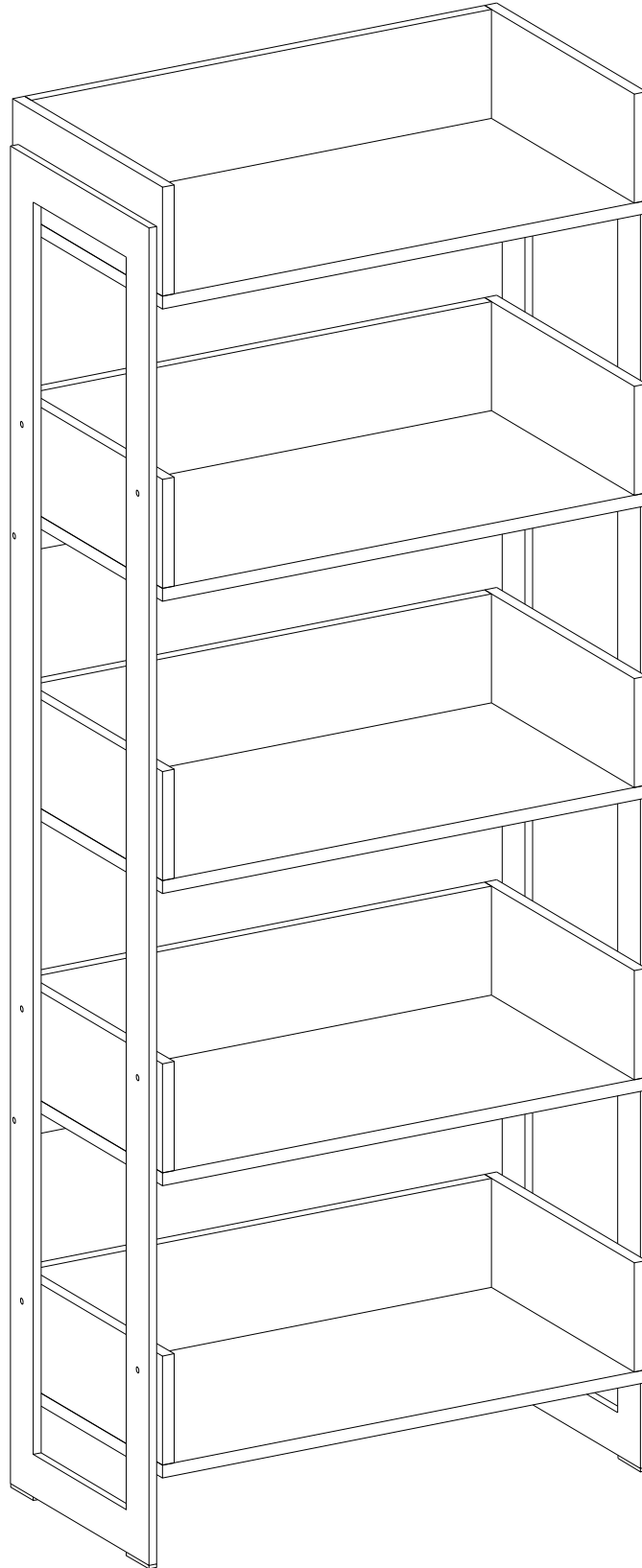

Final Assembly