

- EN** - Please read this instruction manual carefully before attempting to install.
- DE** - Bitte lesen Sie diese Bedienungsanleitung vor der Montage gründlich durch.
- ES** - Por favor lea con atención el manual de instrucciones antes de llevar a cabo el ensamble.
- FR** - Lisez attentivement cette notice avant de commencer le montage.
- IT** - Si prega di consultare il libretto delle istruzioni prima del montaggio.

IMPORTANT/WICHTIG/ATENCIÓN

IMPORTANT/IMPORTANTE



EN - We recommend **1** or more people to install.
DE - Wir empfehlen, dass die Montage von **1** oder mehreren Personen durchgeführt werden sollte.
ES - Recomendamos realizar el ensamble con **1** o más personas.
FR - Il est recommandé d'effectuer le montage à **1** personne(s) ou plus.
IT - È necessaria la presenza di **1** o più persone per il montaggio di questo prodotto.



EN - The expected assembly time is **1 h**.
DE - Die Montagezeit beträgt durchschnittlich **1 h**.
ES - El tiempo aproximado de ensamble es de **1 h**.
FR - Le temps nécessaire est estimé à **1 h**.
IT - Il tempo previsto per il corretto assemblaggio è di **1 h**.



EN - Not intended for use by children.
DE - Nicht geeignet für Kinder.
ES - Producto no apto para niños.
FR - Produit non destiné à être utilisé par des enfants.
IT - Questo prodotto non è destinato all'uso da parte dei bambini.











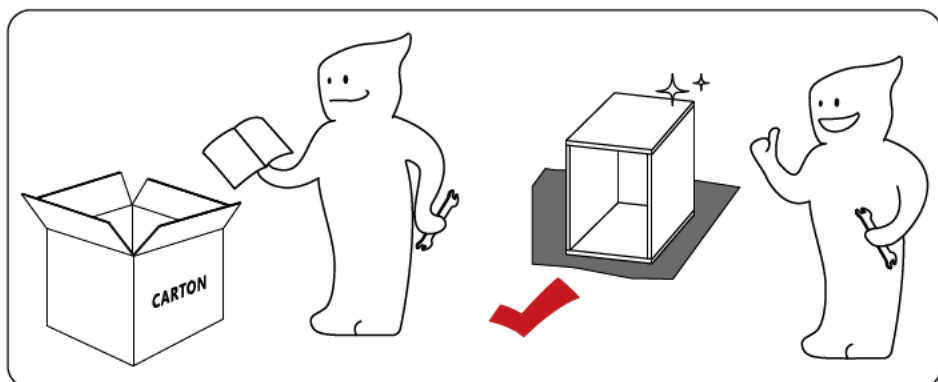
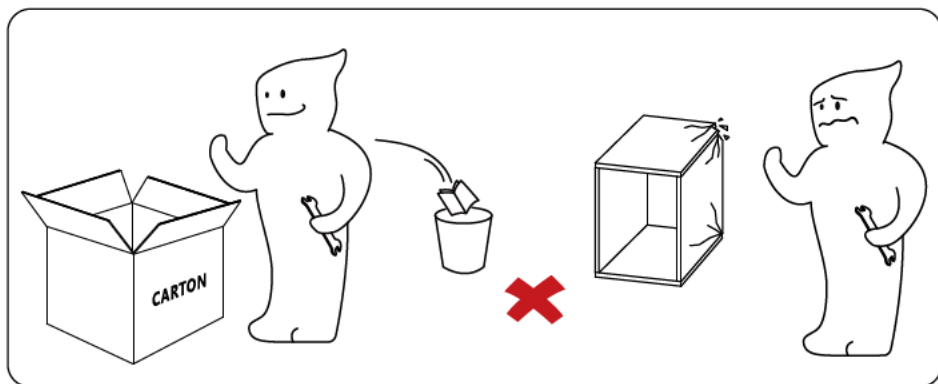



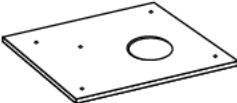
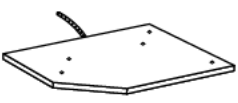
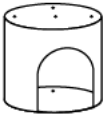
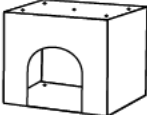

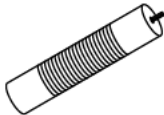
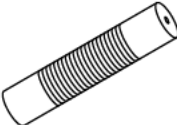
EN - Keep away from fire or other heat sources.
DE - Bitte von Feuer und Hitzequellen fernhalten.
ES - Manténgase alejado de las llamas y otras fuentes de calor.
FR - Tenir à distance des flammes et autres sources de chaleur.
IT - Tenere lontano dal fuoco o da altre fonti di calore.



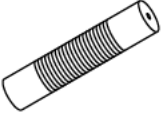
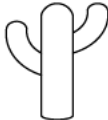

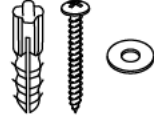

EN - We recommend wearing protective gloves.
DE - Wir empfehlen das Tragen von Schutzhandschuhen.
ES - Recomendamos el uso de guantes de seguridad.
FR - Il est recommandé de porter des gants de protection.
IT - Per il processo di assemblaggio, consigliamo fortemente l'utilizzo di guanti protettivi.

- EN** - Please follow the instruction manuals and use a pad to avoid damage during assembly.
- DE** - Bitte folgen Sie der Anleitung und verwenden Sie eine Unterlage, um Beschädigungen bei der Montage zu vermeiden.
- ES** - Por favor, siga las instrucciones del manual y utilice una cubierta o lona para proteger el producto y el suelo durante la instalación.
- FR** - Suivez les instructions de la notice et utilisez une couverture ou une bâche pour protéger le produit et les sols pendant le montage.
- IT** - Si prega di consultare il manuale illustrativo durante il montaggio e di utilizzare un cuscinetto per evitare possibili danni.





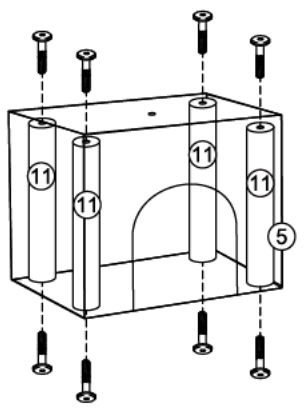
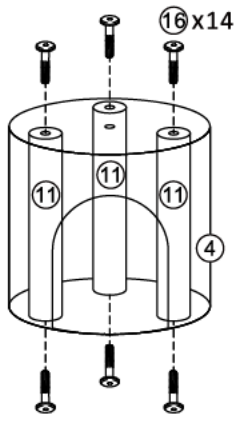

<p>① × 1</p> 	<p>② × 1</p> 	<p>③ × 1</p> 	
<p>④ × 1</p> 	<p>⑤ × 1</p> 	<p>⑥ × 1</p> 	
<p>⑦ × 1</p>  <p>35cm</p>	<p>⑧ × 4</p>  <p>40cm</p>	<p>⑨ × 2</p>  <p>40cm</p>	
<p>⑩ × 1</p>  <p>15cm</p>	<p>⑪ × 7</p>  <p>22cm</p>	<p>⑫ × 1</p>  <p>30cm</p>	
<p>⑬ × 1</p> 	<p>⑭ × 1</p> 	<p>⑮ × 1</p> 	<p>⑯ × 26</p>  <p>35mm</p>
<p>⑰ × 2</p>  <p>25mm</p>	<p>⑱ × 3</p> 	<p>⑲ × 1</p> 	<p>⑳ × 1</p> 

1

④		x1
⑤		x1
⑪		x7
⑯		x14



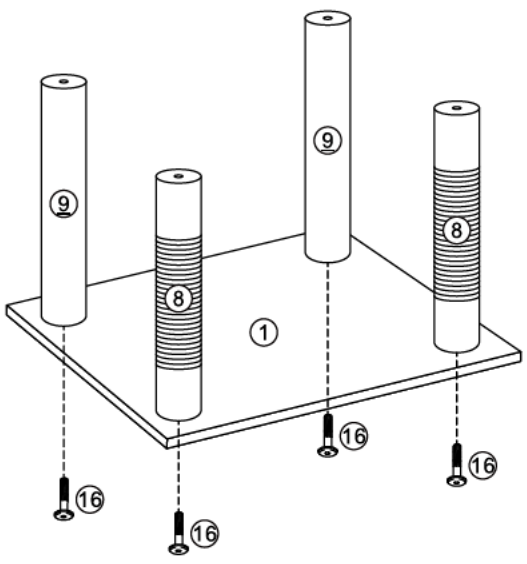

2

①		x1
⑧		x2
⑨		x2
⑯		x4



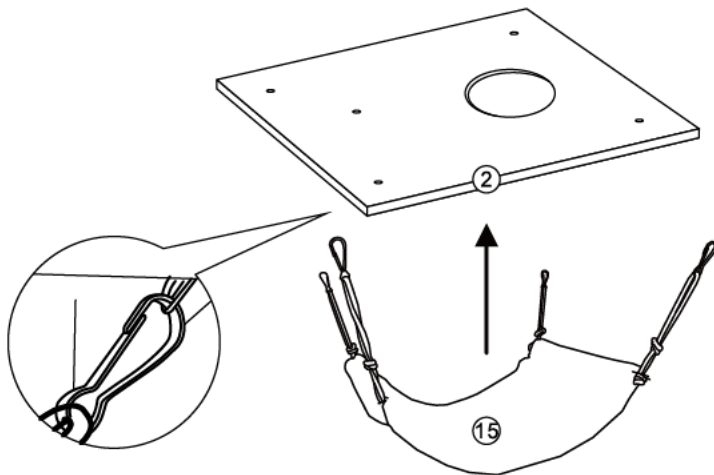

3

②	 x1
⑮	 x1



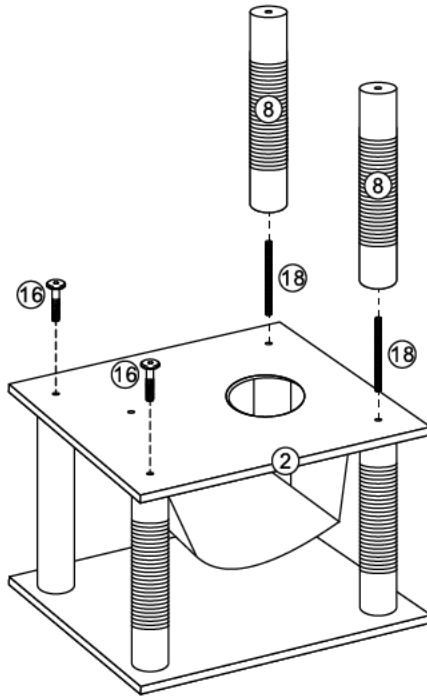
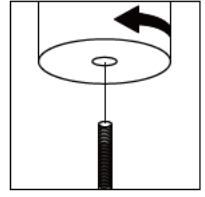
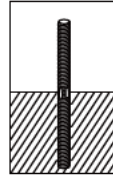
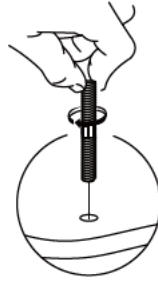

4

⑧		x2
⑯		x2
⑱		x2



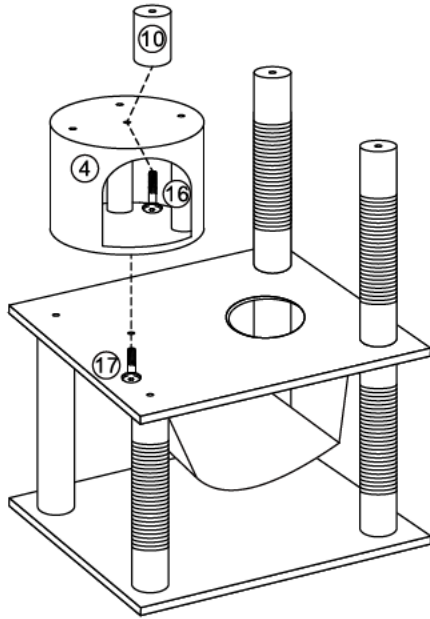

5

10		x1
16		x1
17		x1





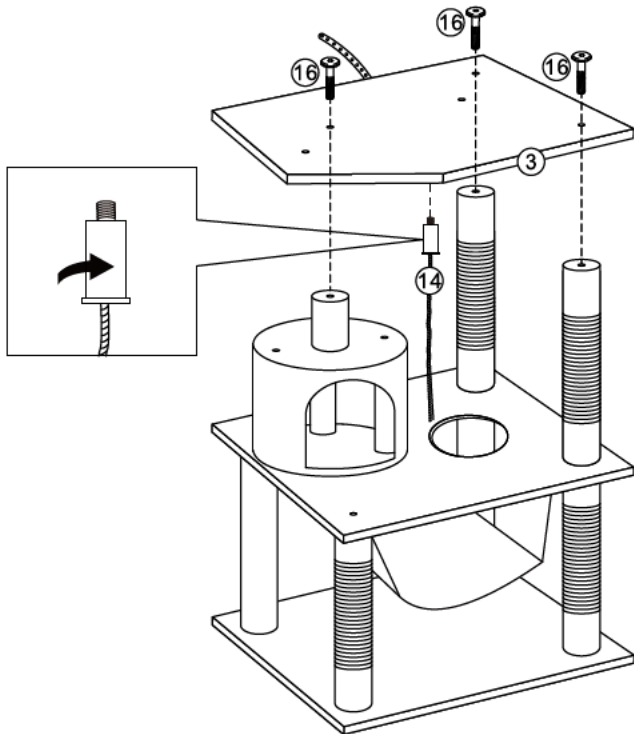

6

3		x1
14		x1
16		x3



8

⑥		x1
⑦		x1
⑬		x1
⑯		x1
⑱		x1

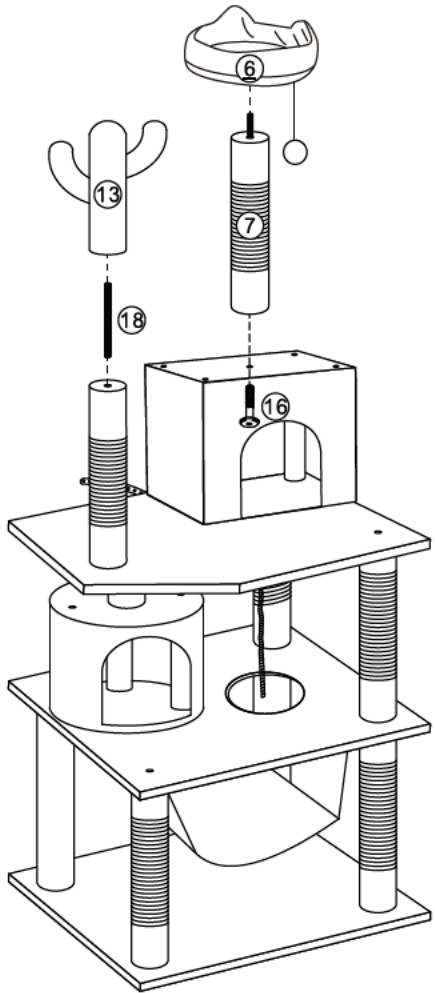

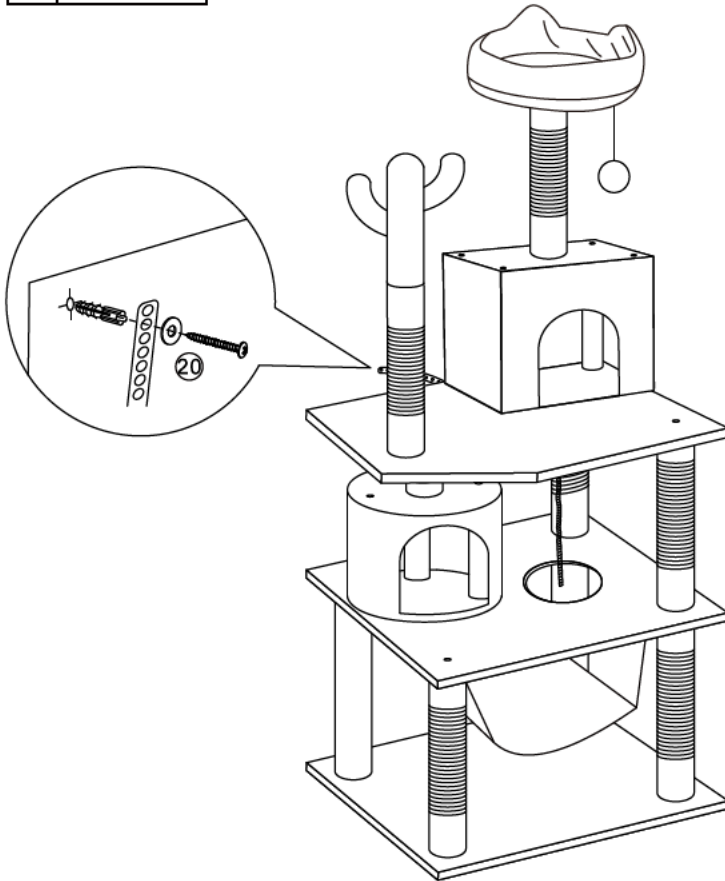
9

EN - Note: Please remove the bell(s) on the hanging fur ball(s) if your cats tend to eat foreign objects.

DE - Hinweis: Bitte entfernen Sie die Glocke(n) an den hängenden Fellbällen, wenn Ihre Katzen dazu neigen, Fremdkörper zu fressen.

ES - Nota: Por favor, retira los cascabeles de la(s) bola(s) de pelo colgante(s) si tus gatos tienden a comer cosas extrañas.

FR - NB: Veuillez retirer la/les clochette(s) de la/des boule(s) de fourrure suspendue(s) si vos chats ont tendance à manger des corps étrangers.

IT - Nota: Se i vostri gatti tendono a ingerire corpi estranei, si prega di rimuovere le campane dalle palle di pelo appese.