

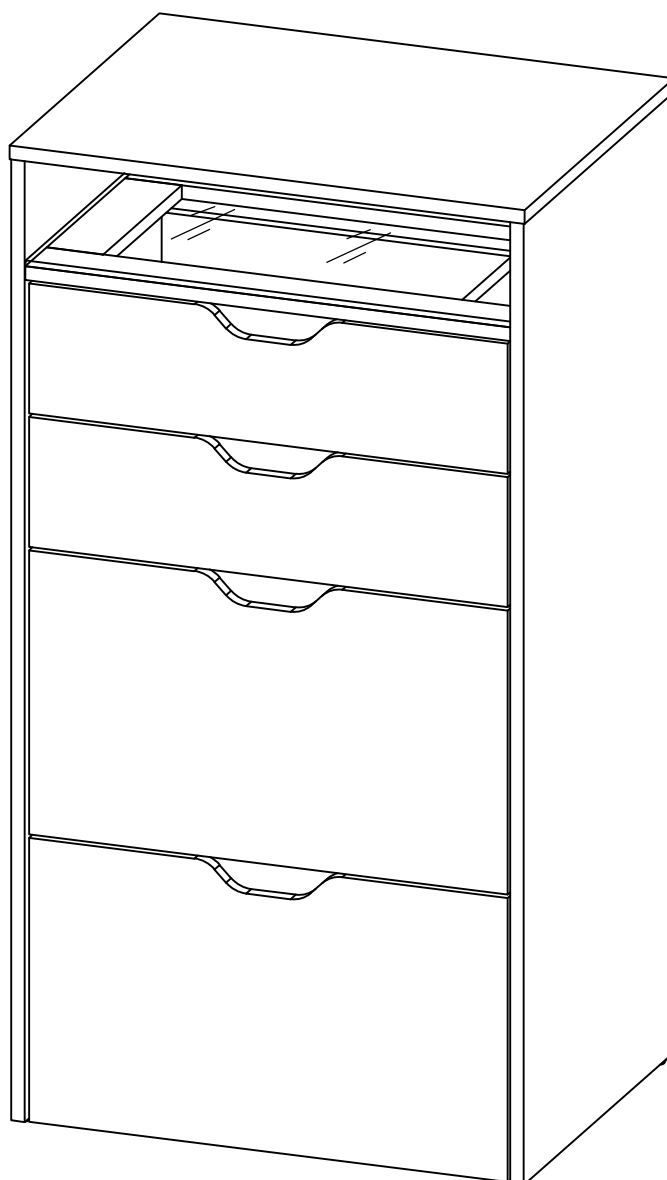

# Table

## Item # HS202502-07

### INSTRUCTION



 Part of the steps suggest  
two people install

# Main Components

Please check you have all the parts listed below

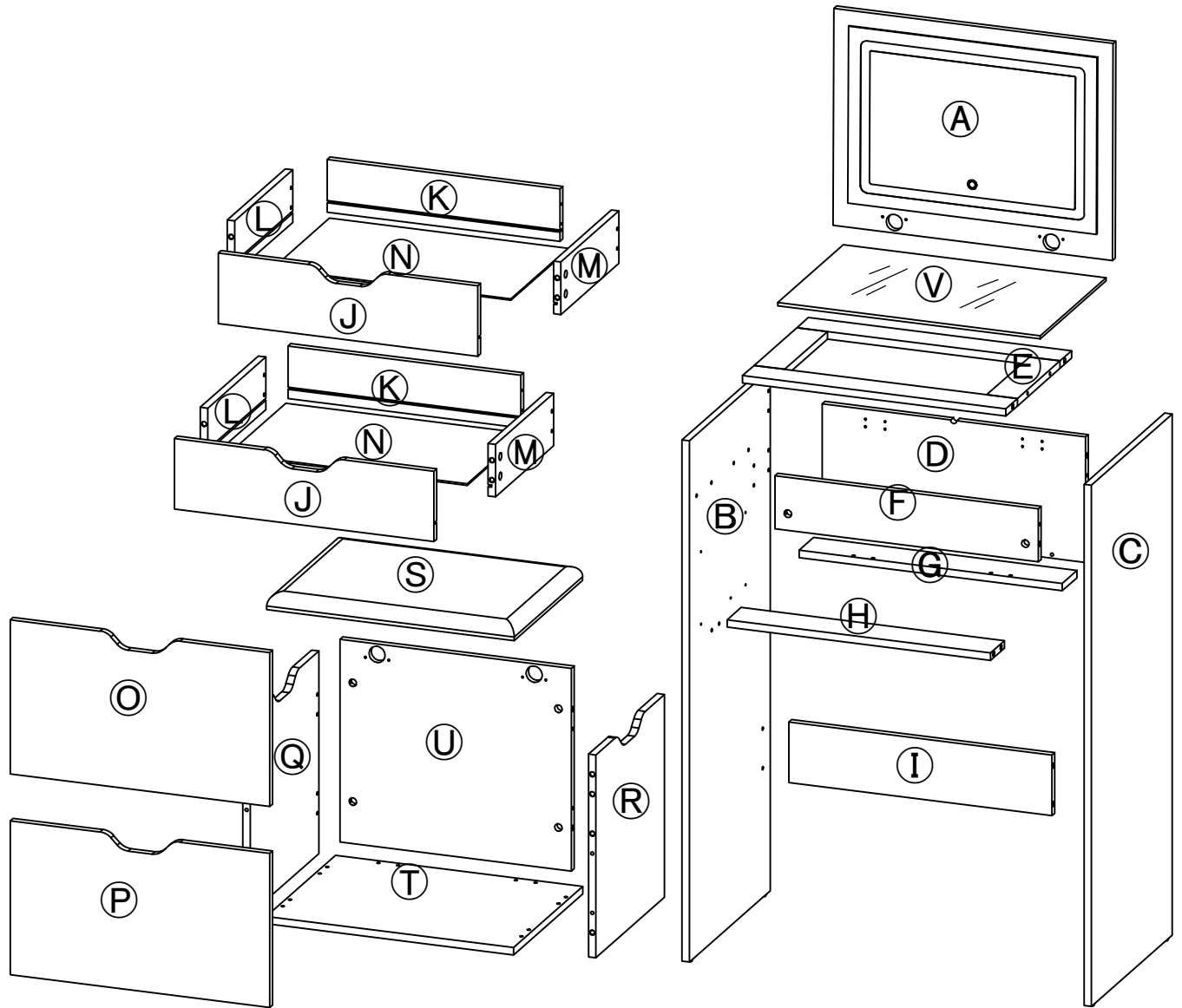

# Component Panels & Part List

Please check you have all the parts listed below

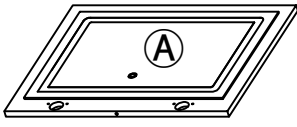

1PC

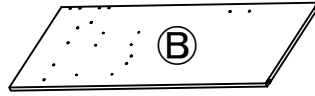

1PC

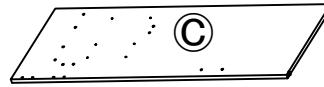

1PC

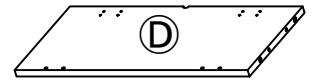

1PC

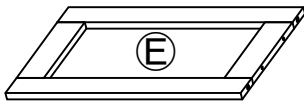

1PC

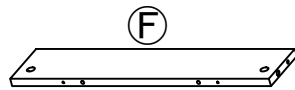

1PC

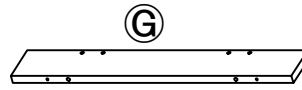

1PC

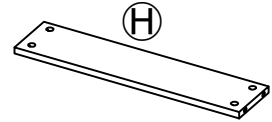

1PC

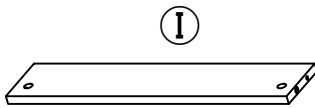

1PC

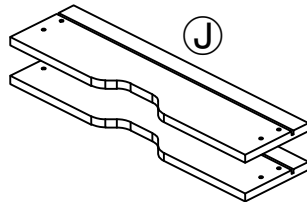

2PCS

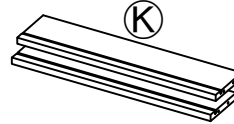

2PCS

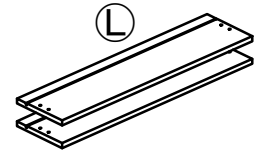

2PCS

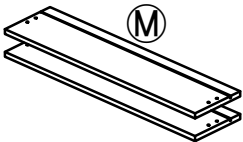

2PCS

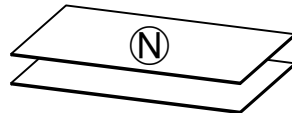

2PCS

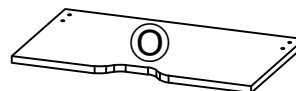

1PC

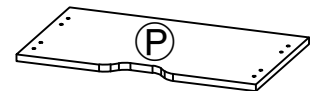

1PC

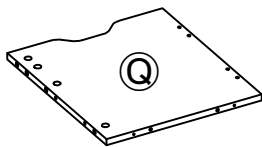

1PC

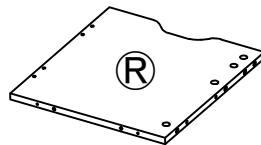

1PC

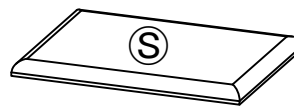

1PC

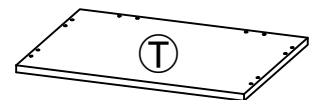

1PC

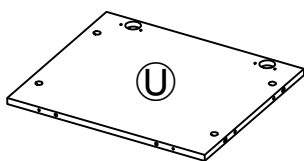

1PC



1PC

# Fixings, Fittings And Tools

Please check all the fittings listed below

**Note:** The quantities below are the correct amount to complete the assembly. In some case more fittings may be supplied than be required.

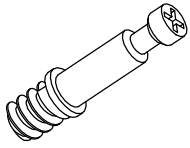

① Ø6\*L27mm  
36PCS

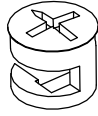

② Ø12\*9mm  
36PCS



③ Ø5\*30mm  
30PCS

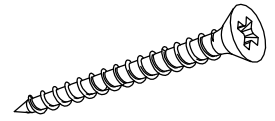

④ Ø4\*38mm  
18PCS



⑤ Ø3.5\*11mm  
20PCS

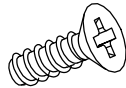

⑥ Ø4\*12mm  
24+1PCS

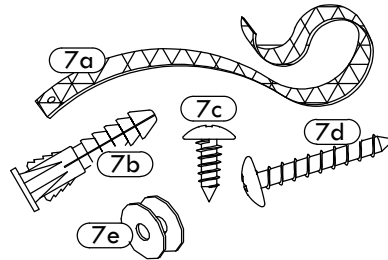

⑦ 1SET



⑧ Ø20\*6MM  
4PCS



⑨ Ø4\*12mm  
1PC



⑩ Ø3.3\*17mm  
1PC

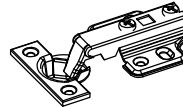

⑪ Ø26mm  
2PCS

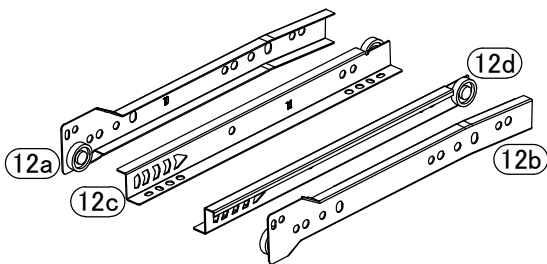

⑫ 10"  
2SETS



⑬ Ø26mm  
2PCS

# Assembly Step

## Step 1

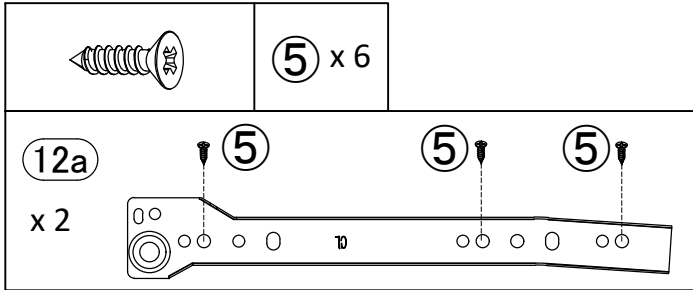
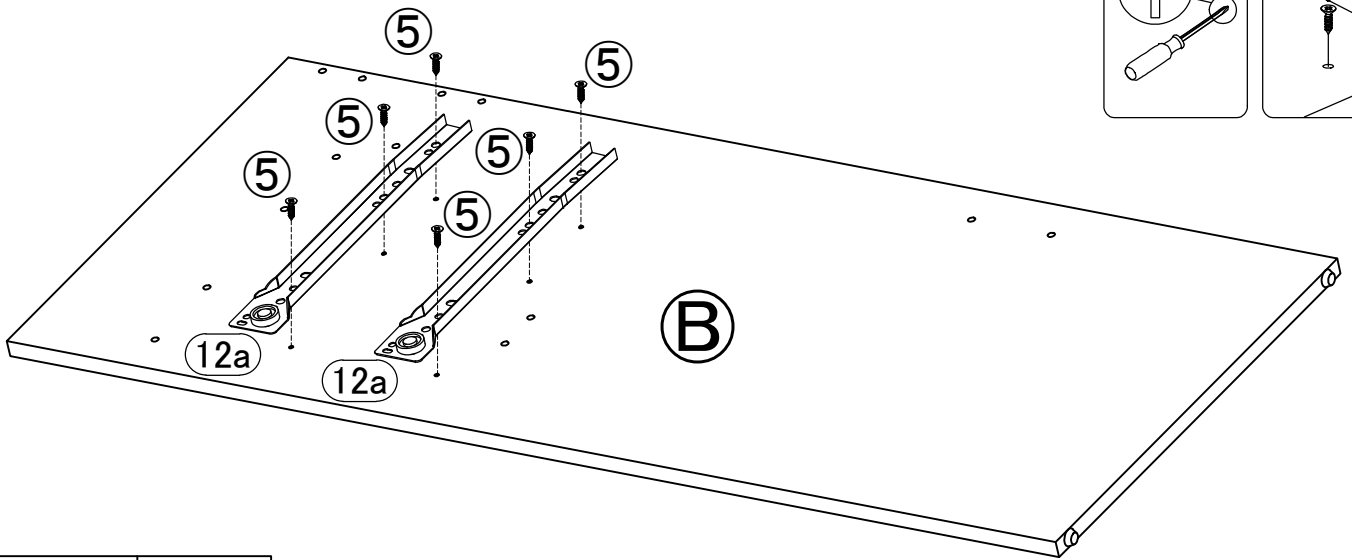
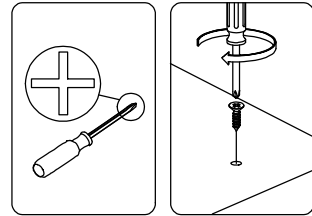

## Step 2

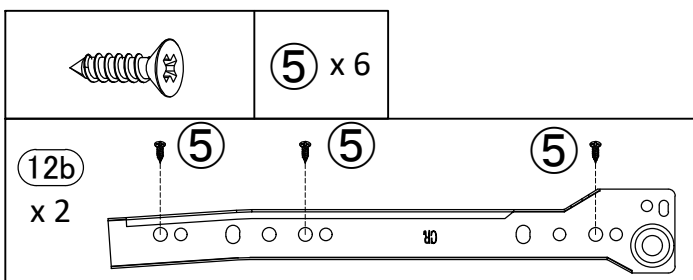
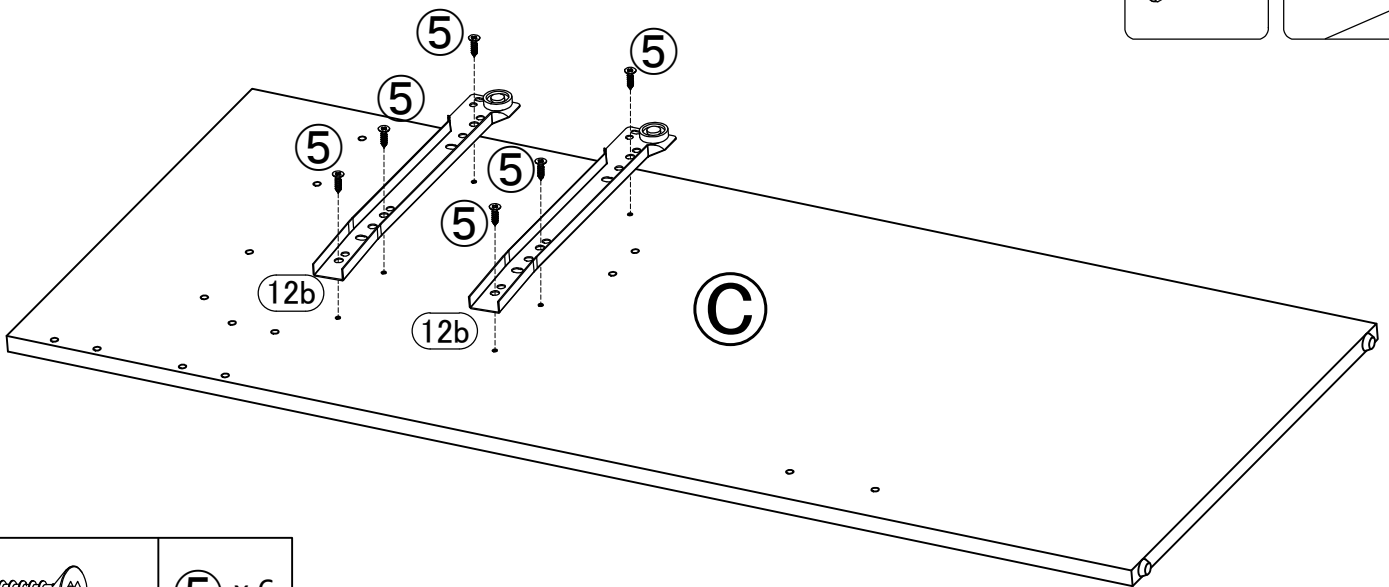
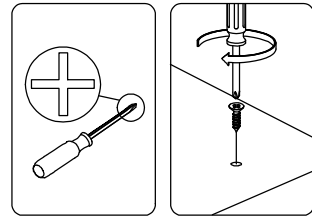

# Assembly Step

## Step 3

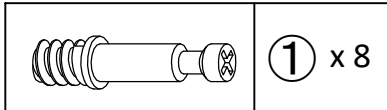
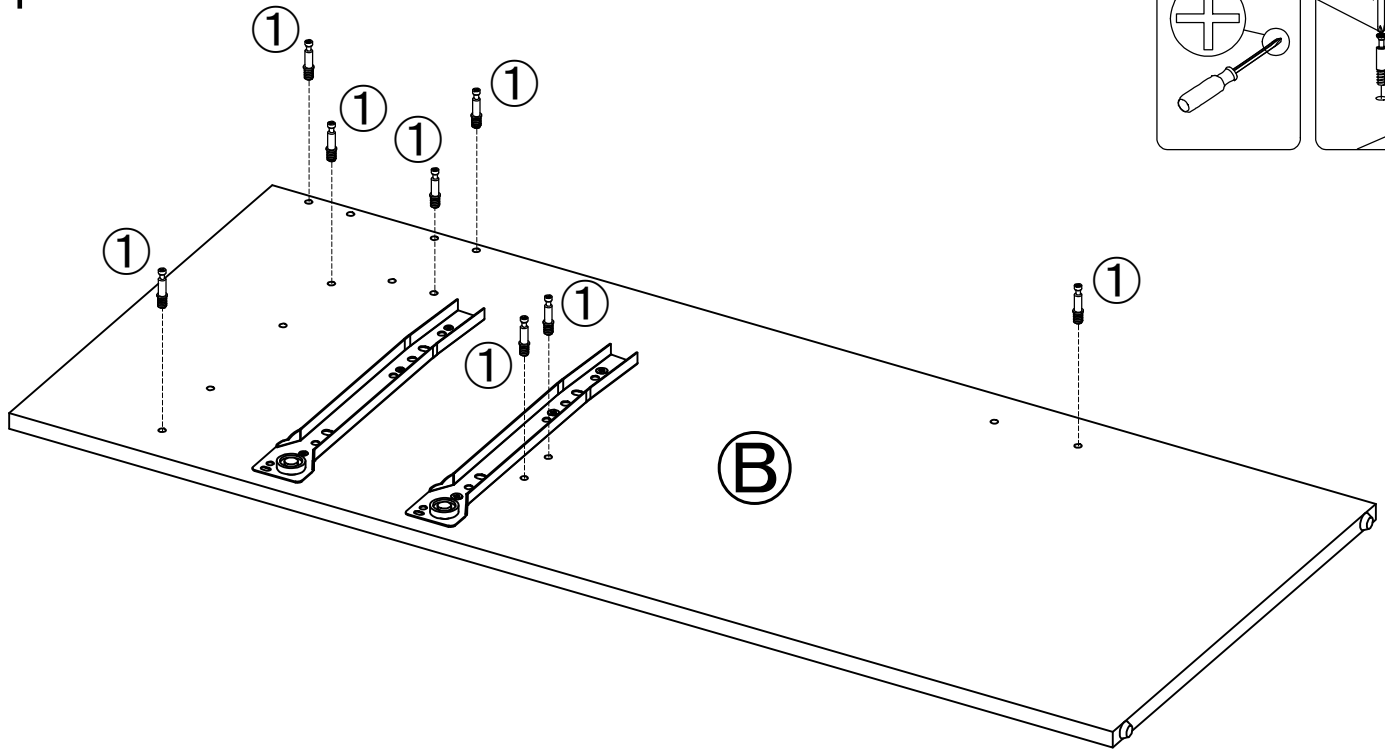
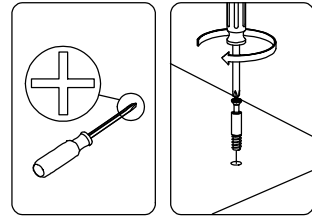

## Step 4

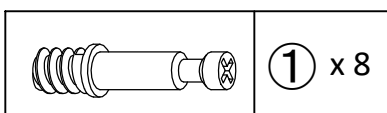
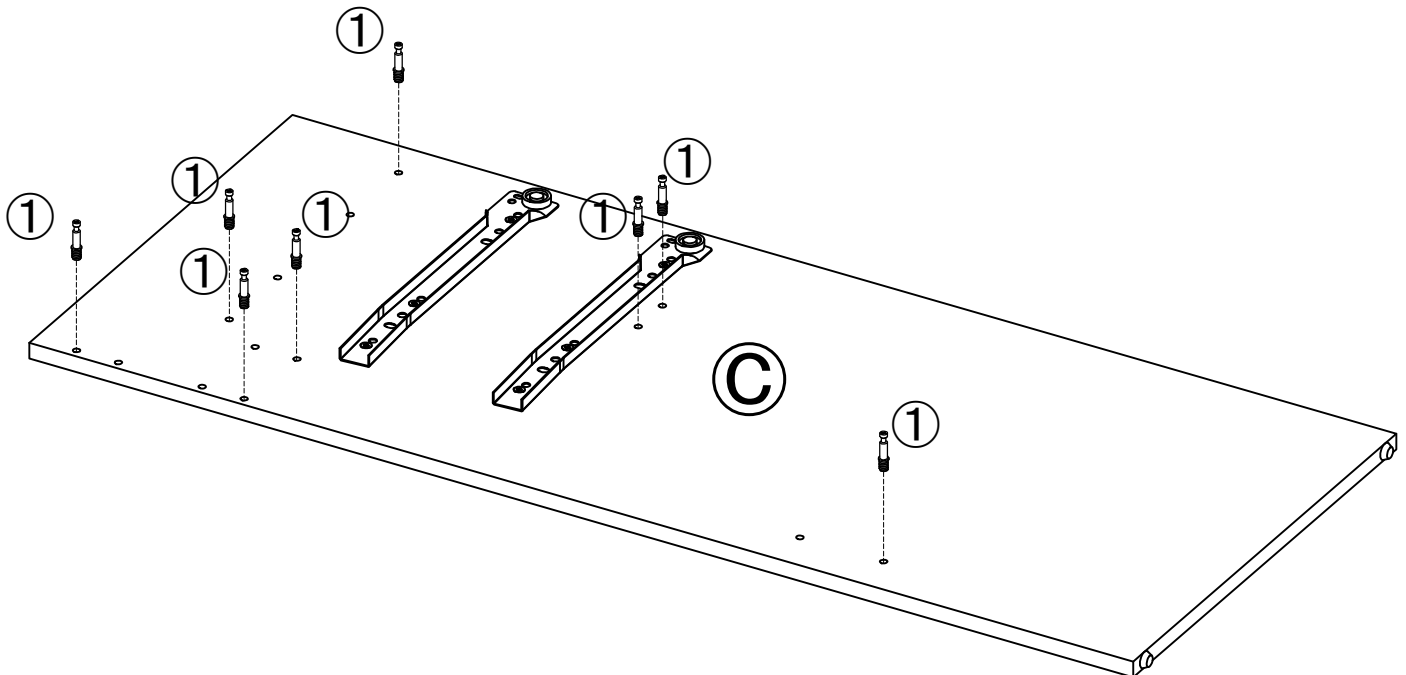
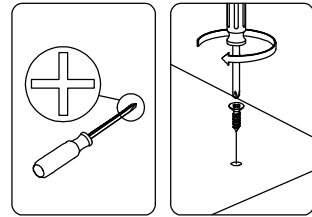

# Assembly Step

## Step 5

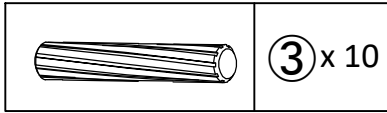
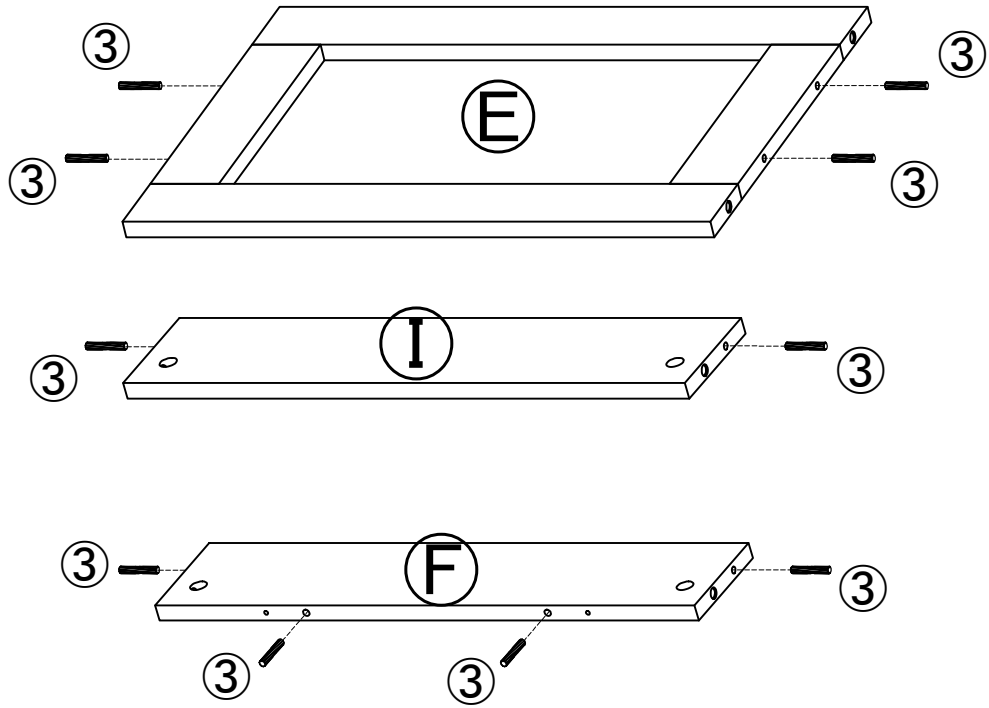

## Step 6

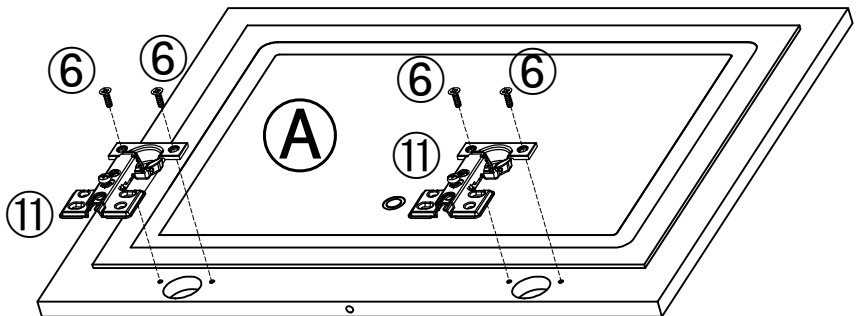
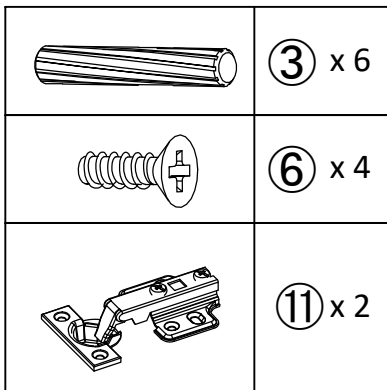
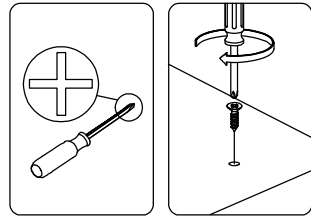
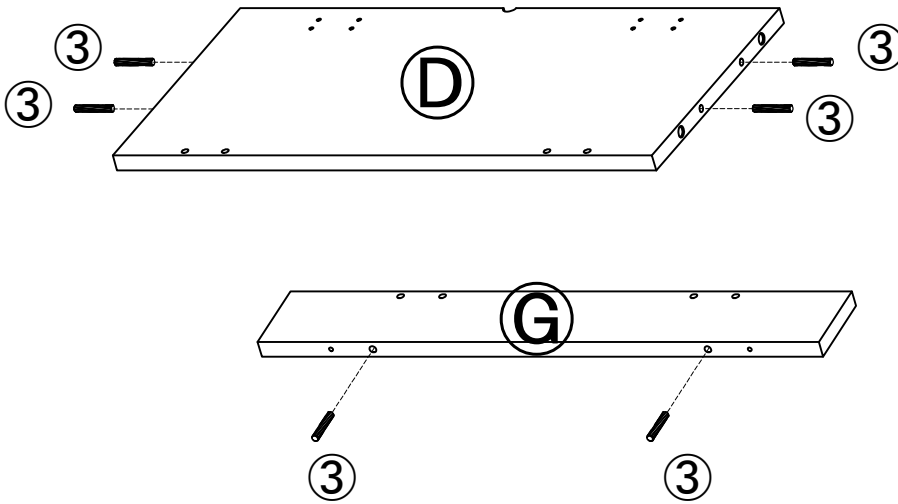

# Assembly Step

## Step 7

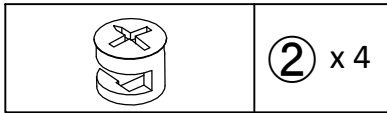
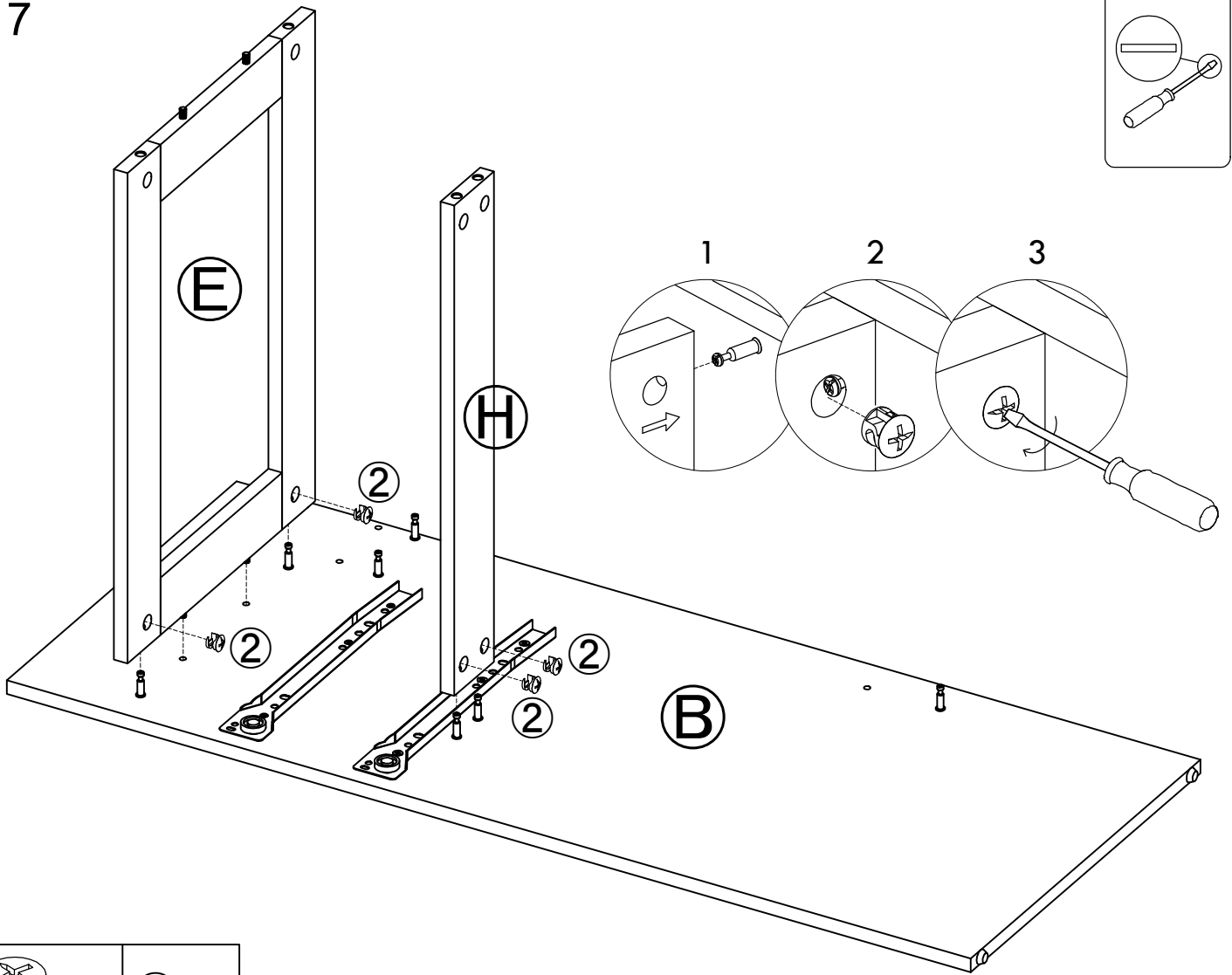

## Step 8

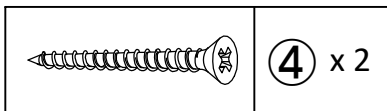
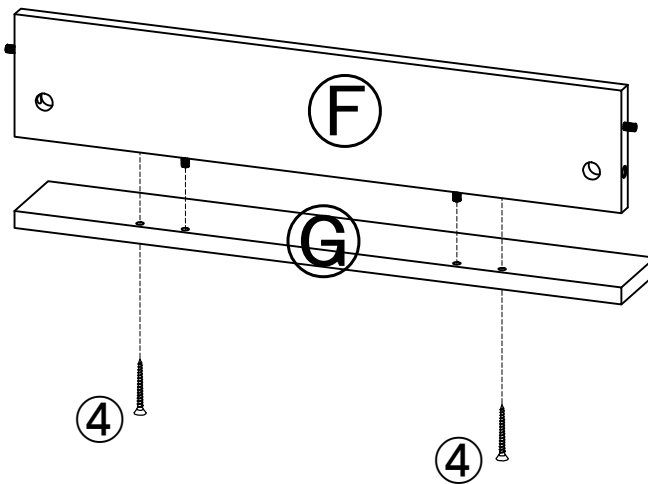

# Assembly Step

## Step 9

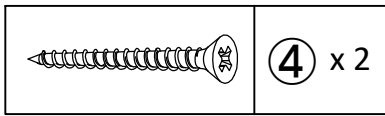
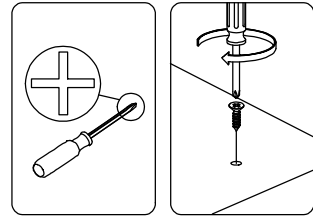
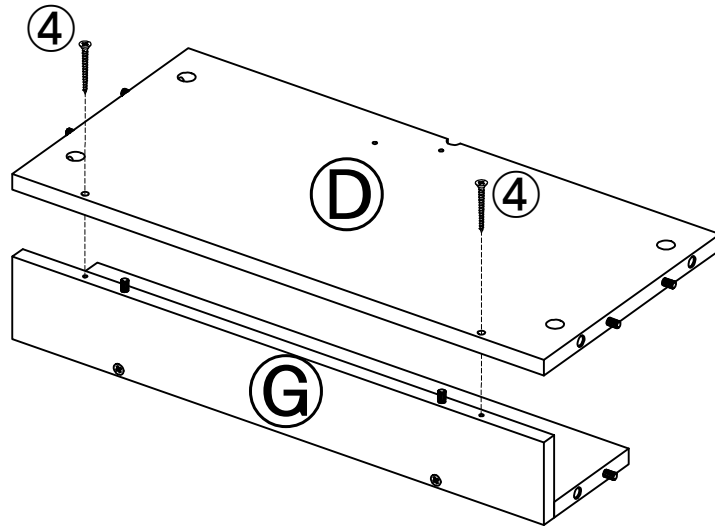

## Step 10

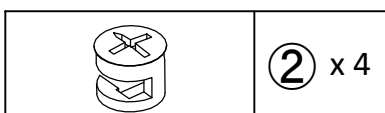
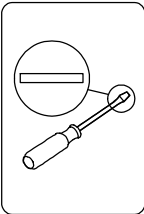
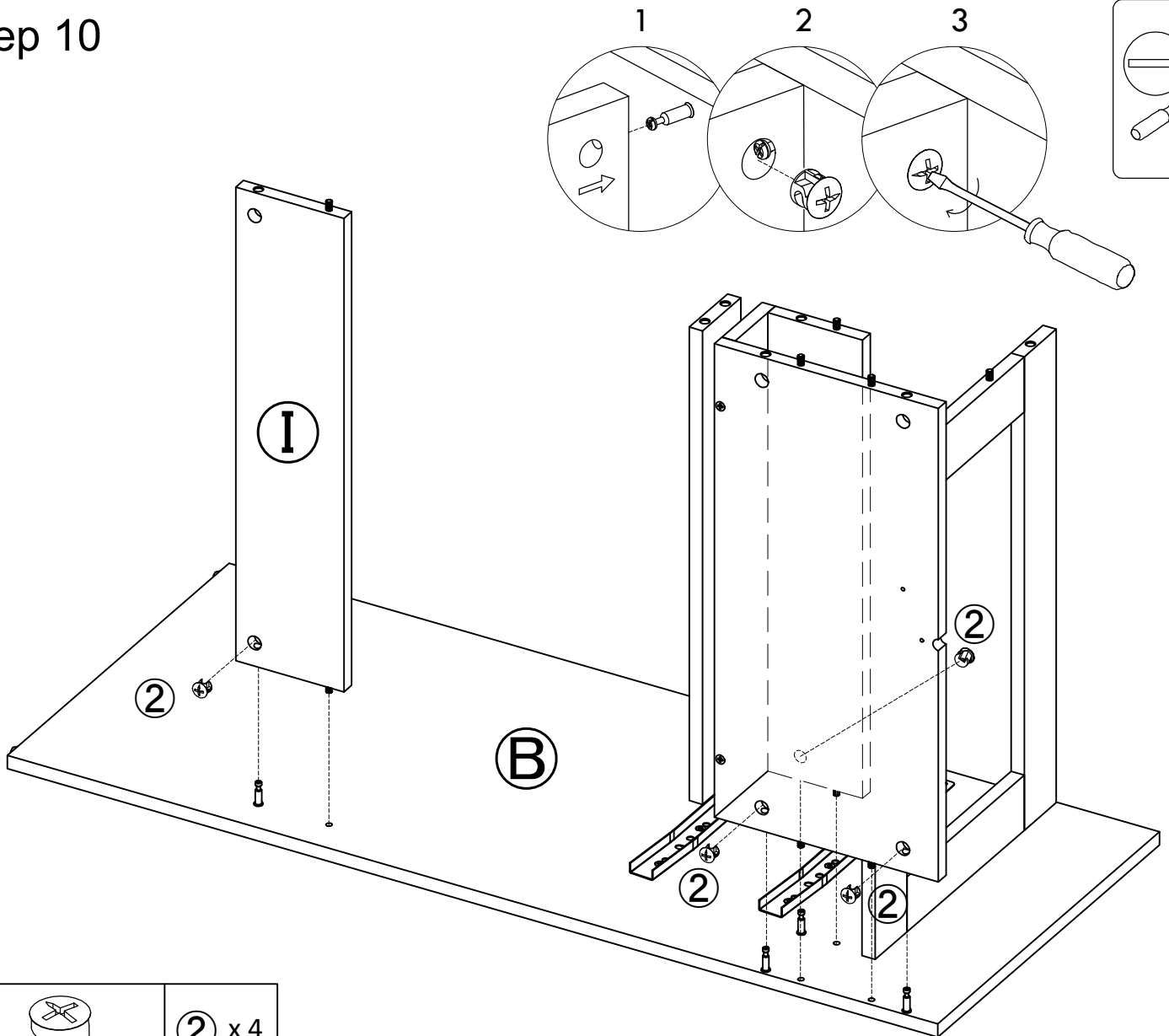



# Assembly Step

## Step 12

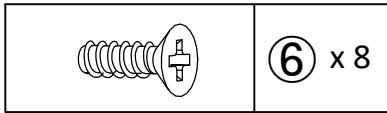
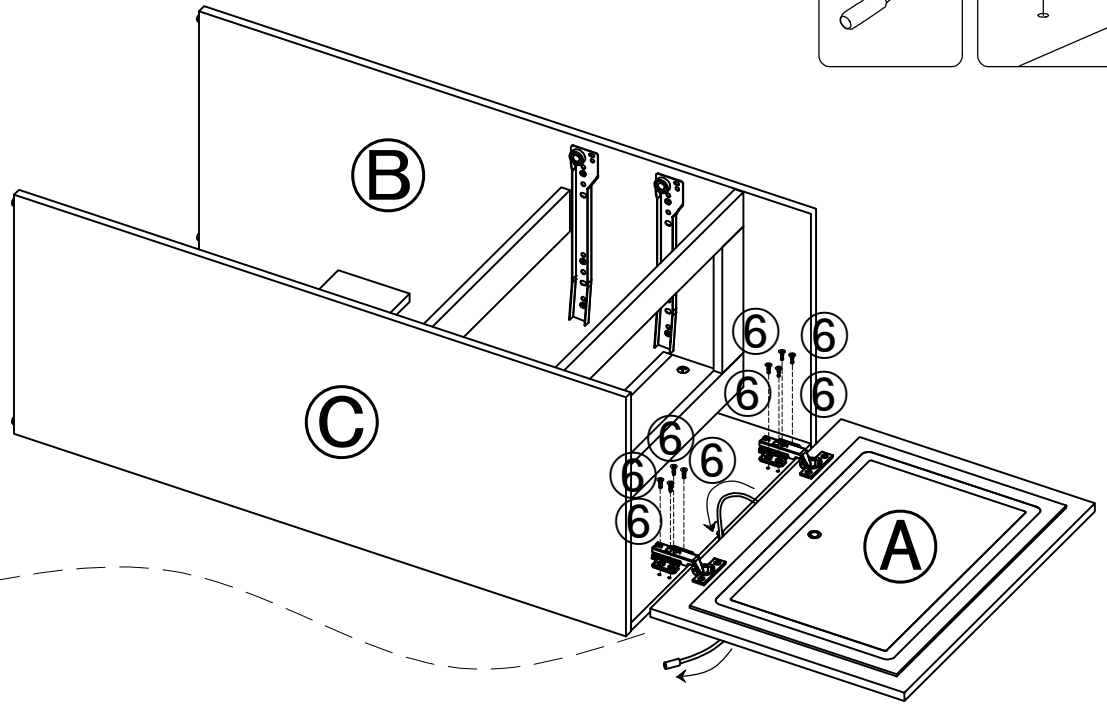
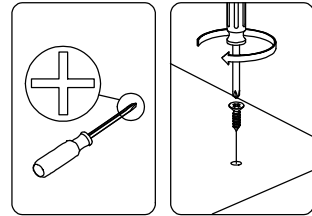
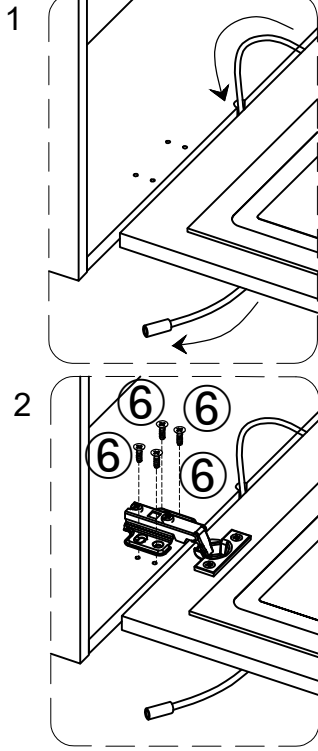

## Step 13

If necessary, adjust hinges to properly align doors as shown below.

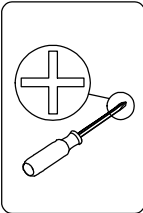

Adjusting possibilities

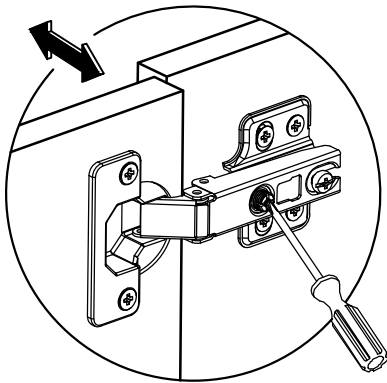

Lateral Adjustment

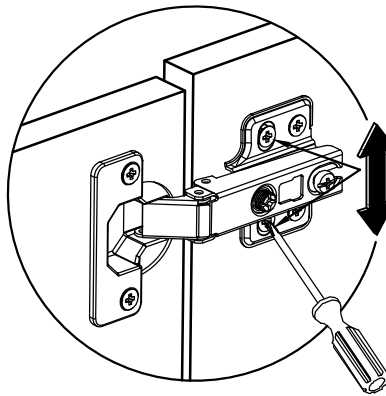

Vertical adjustment

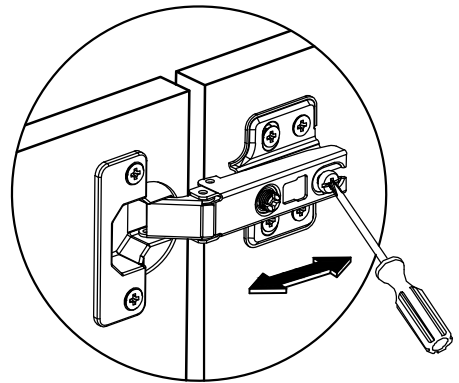

Forward/backwards adjustment

# Assembly Step

## Step 14

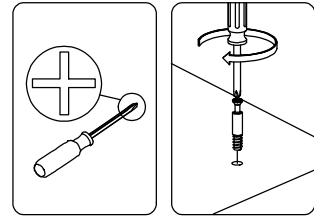
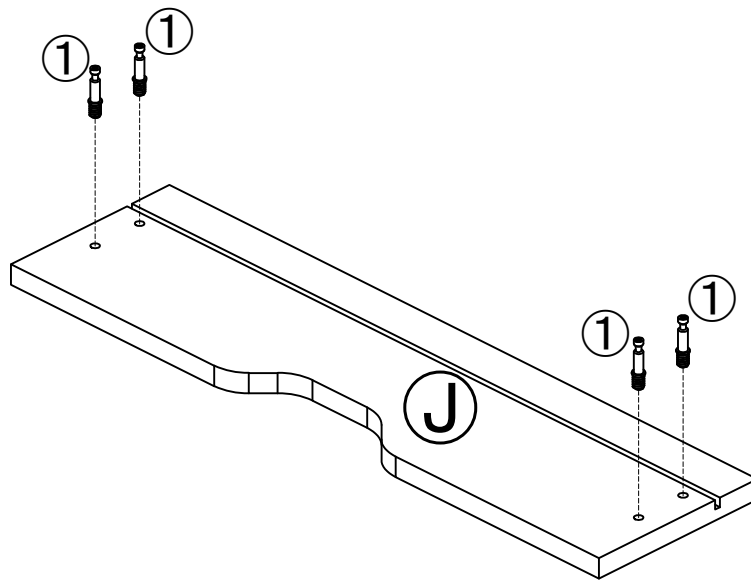

x 2

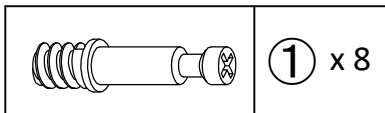

## Step 15

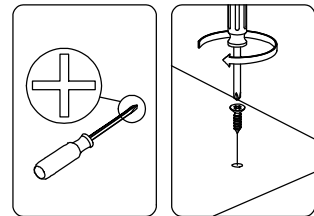
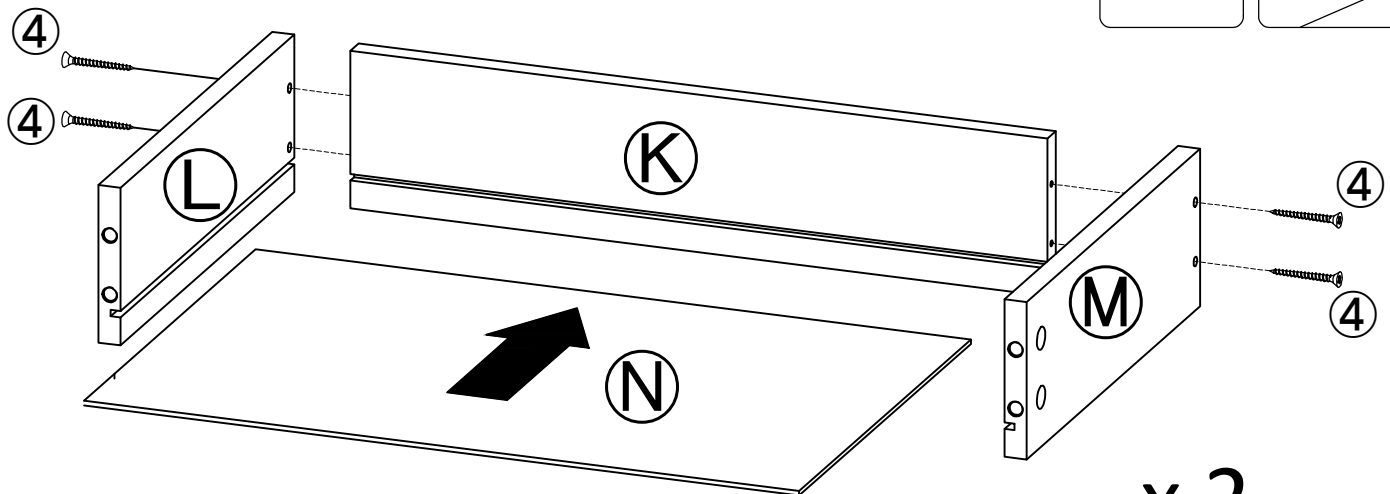

x 2

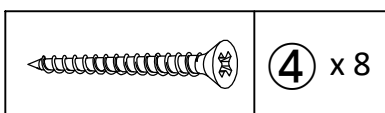

# Assembly Step

## Step 16

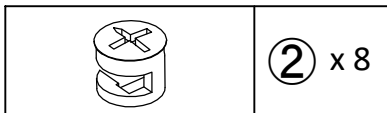
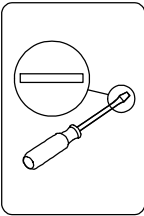
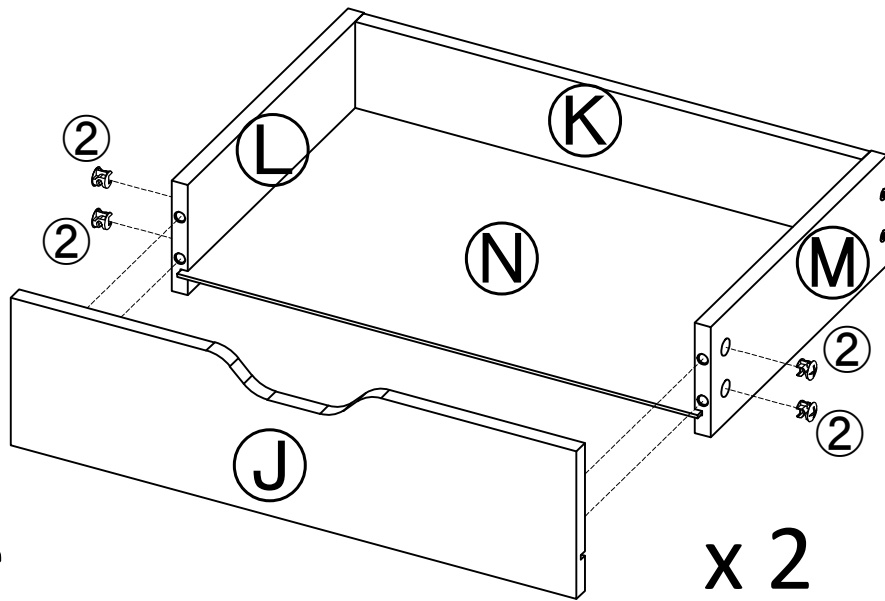
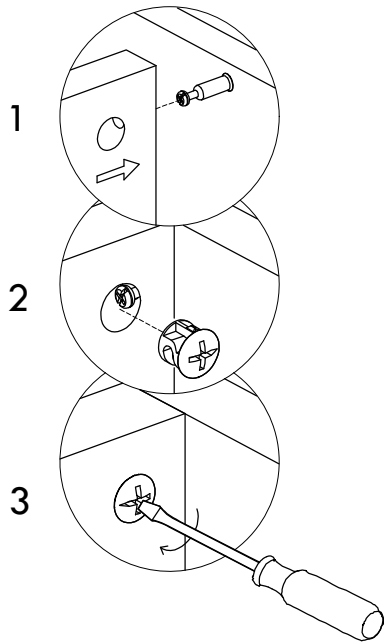

## Step 17

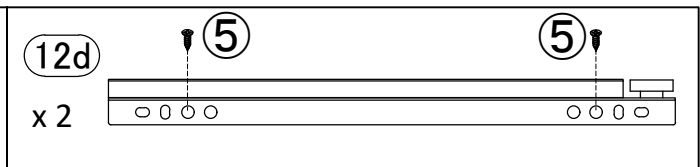
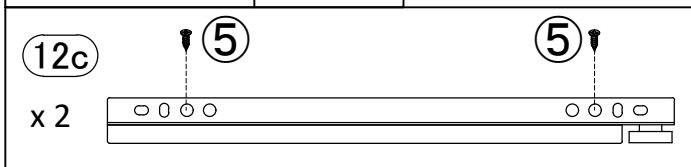
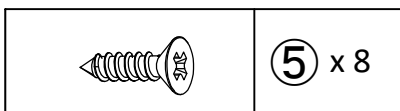
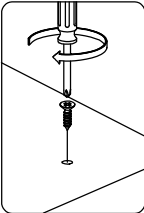
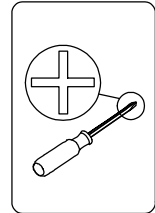
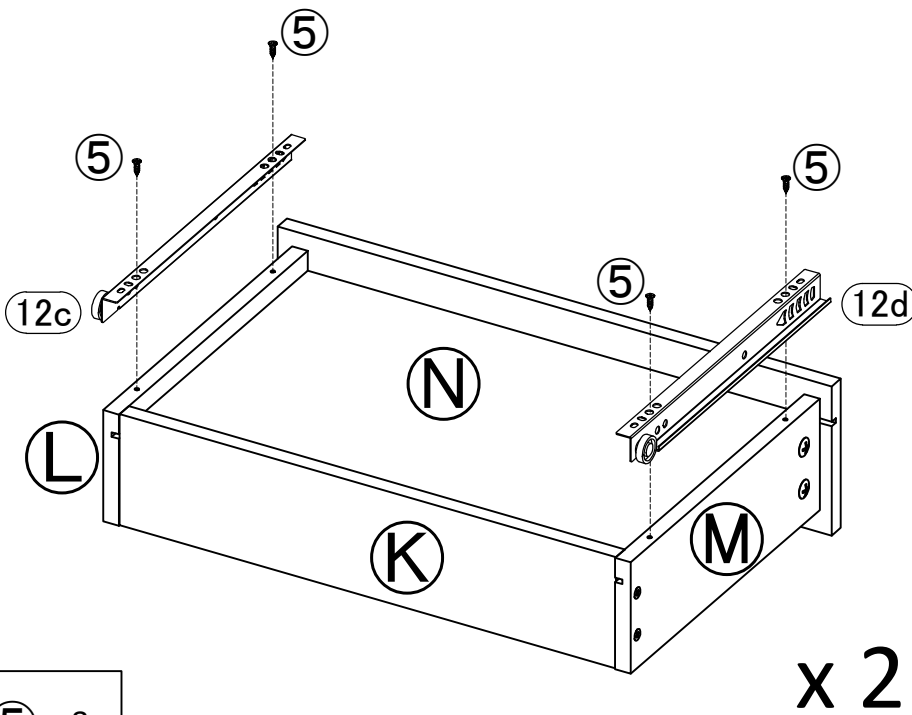

# Assembly Step

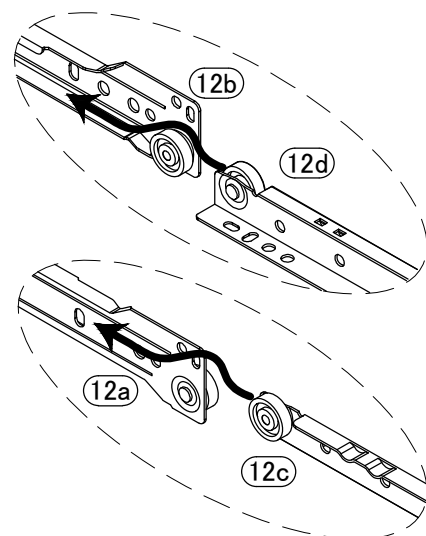
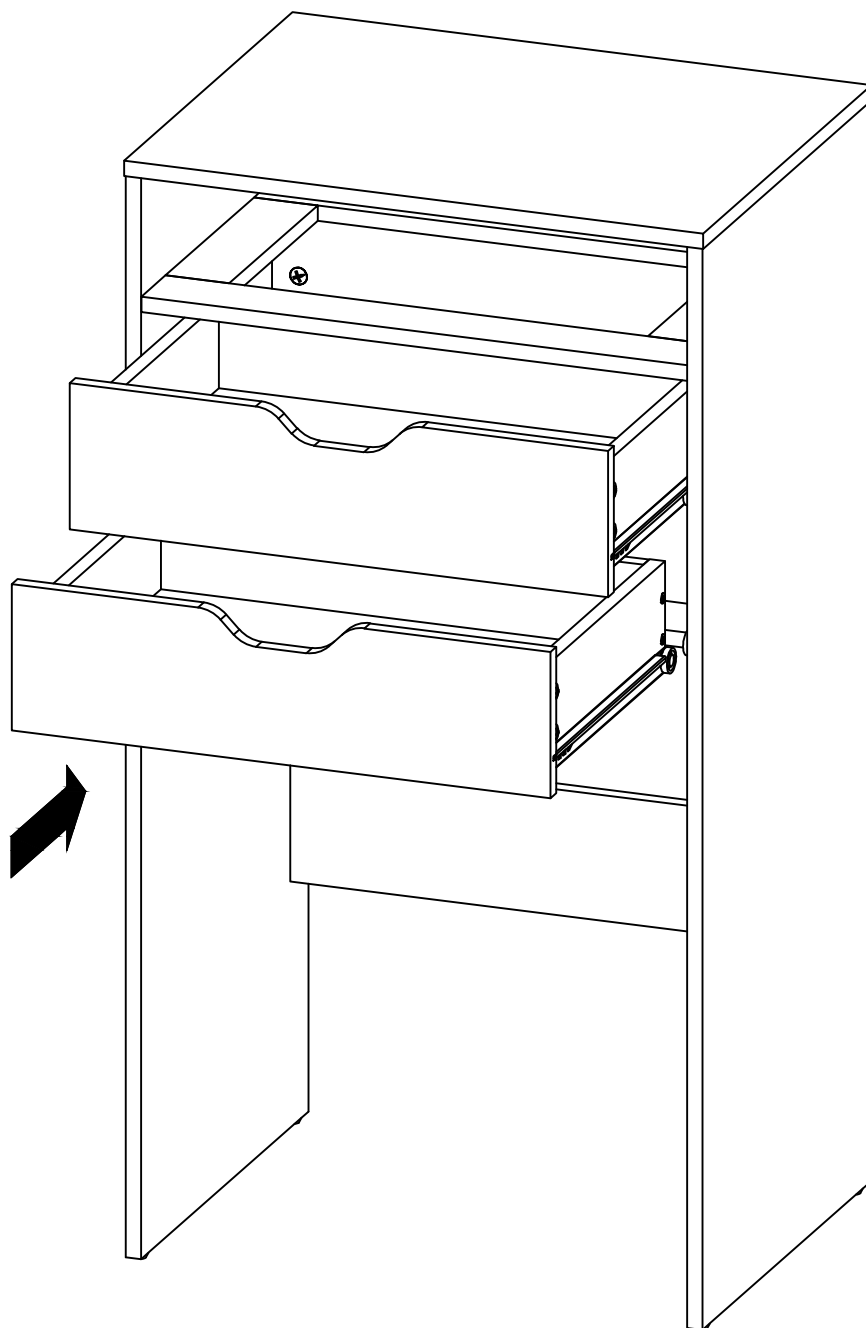

## Step 18

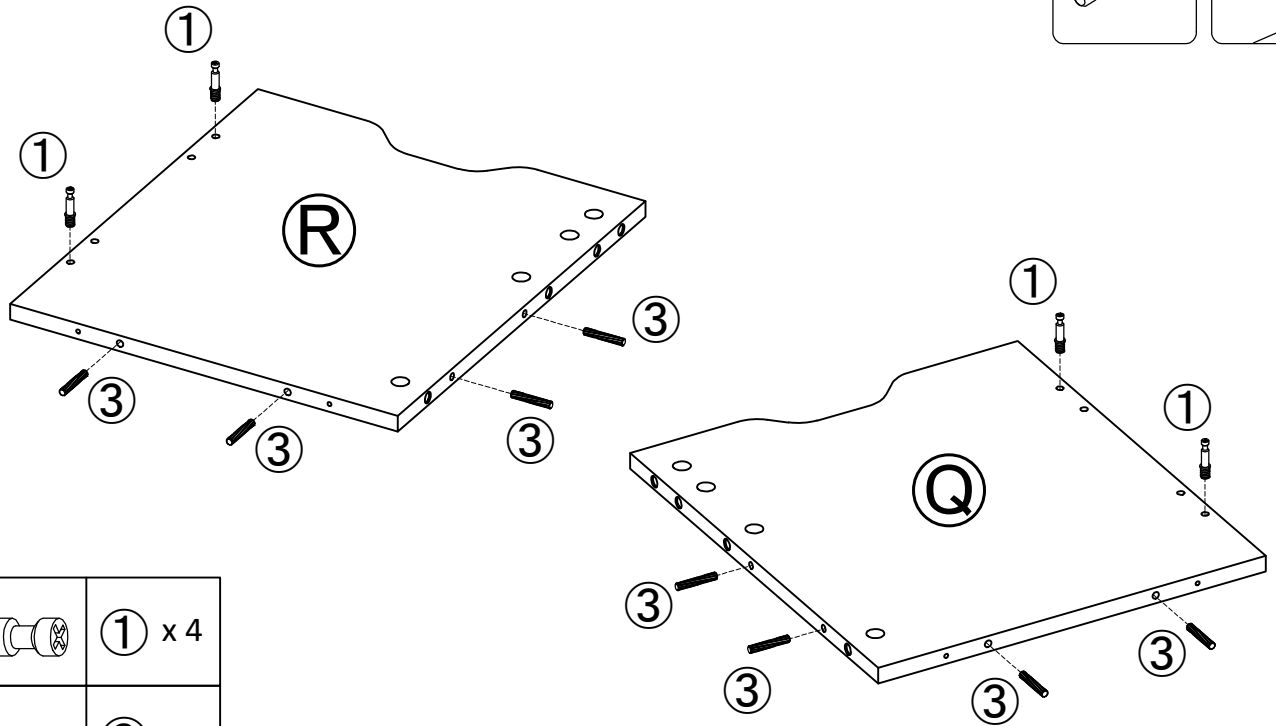
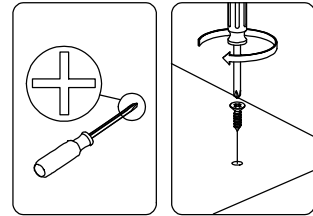

# Assembly Step

## Step 19

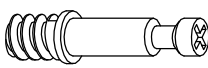

	① x 4
	③ x 8

## Step 20

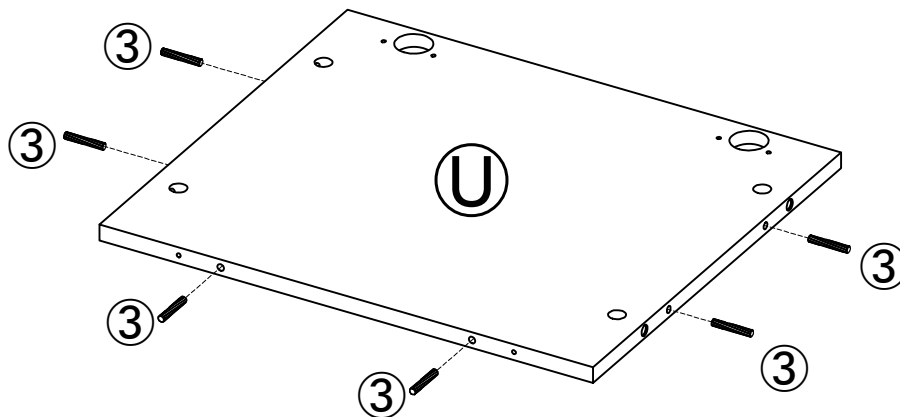

	③ x 6
--	-------

# Assembly Step

## Step 21

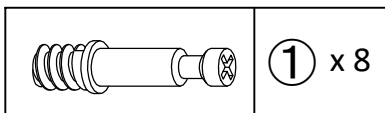
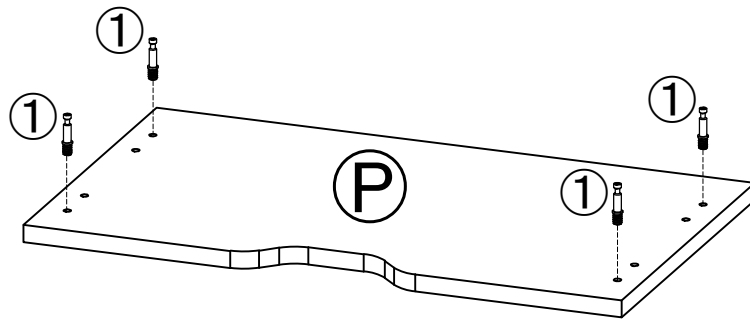
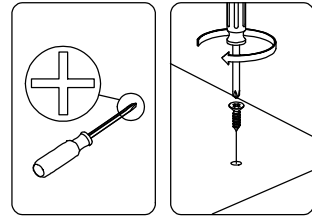
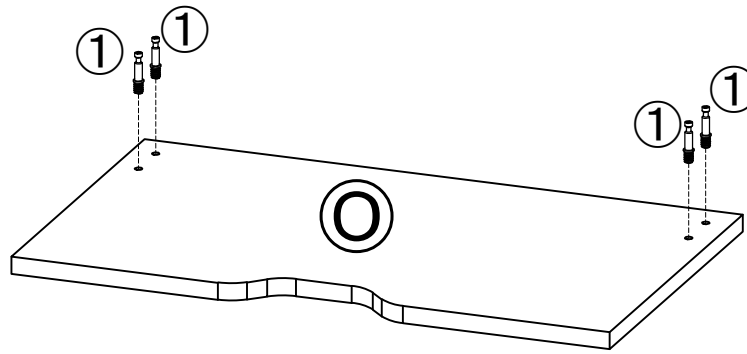

## Step 22

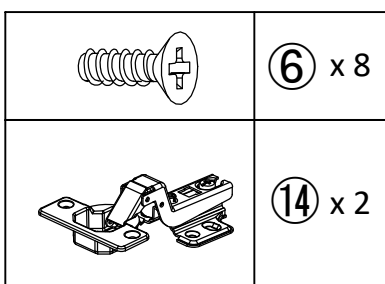
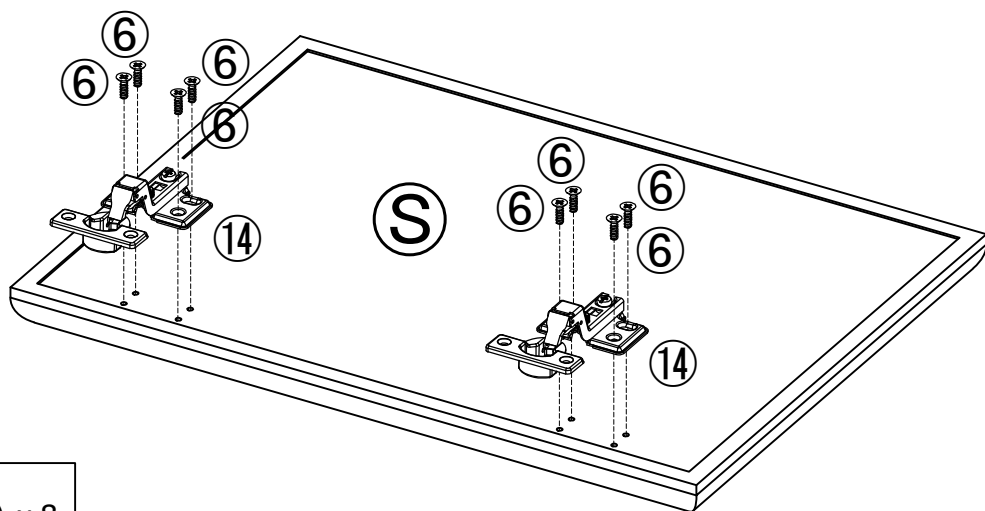
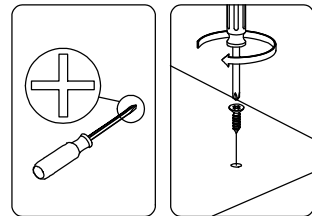

# Assembly Step

## Step 23

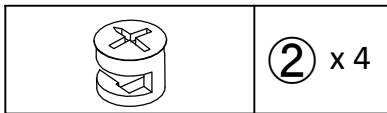
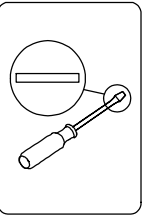
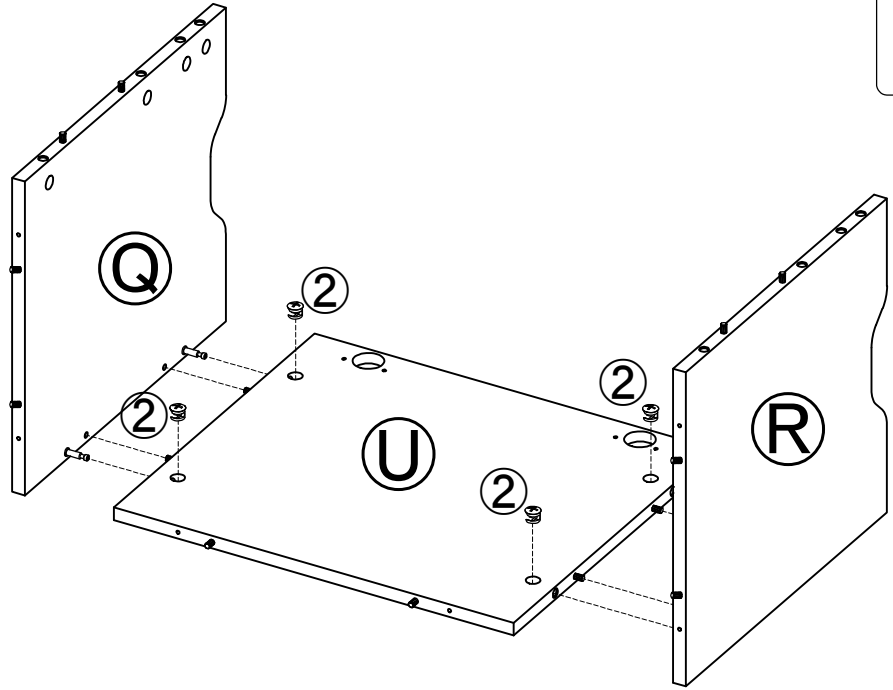
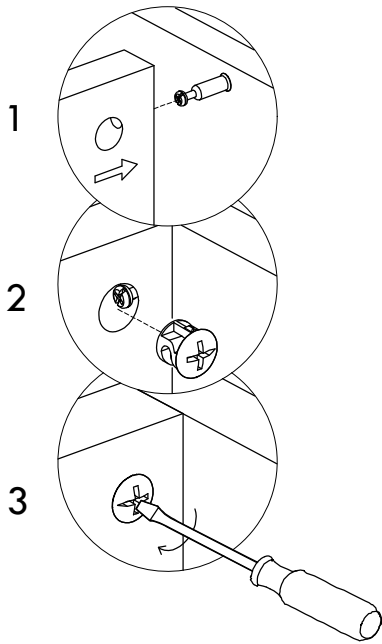

## Step 24

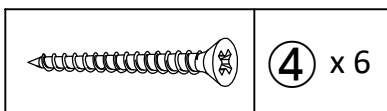
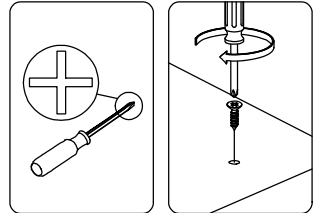
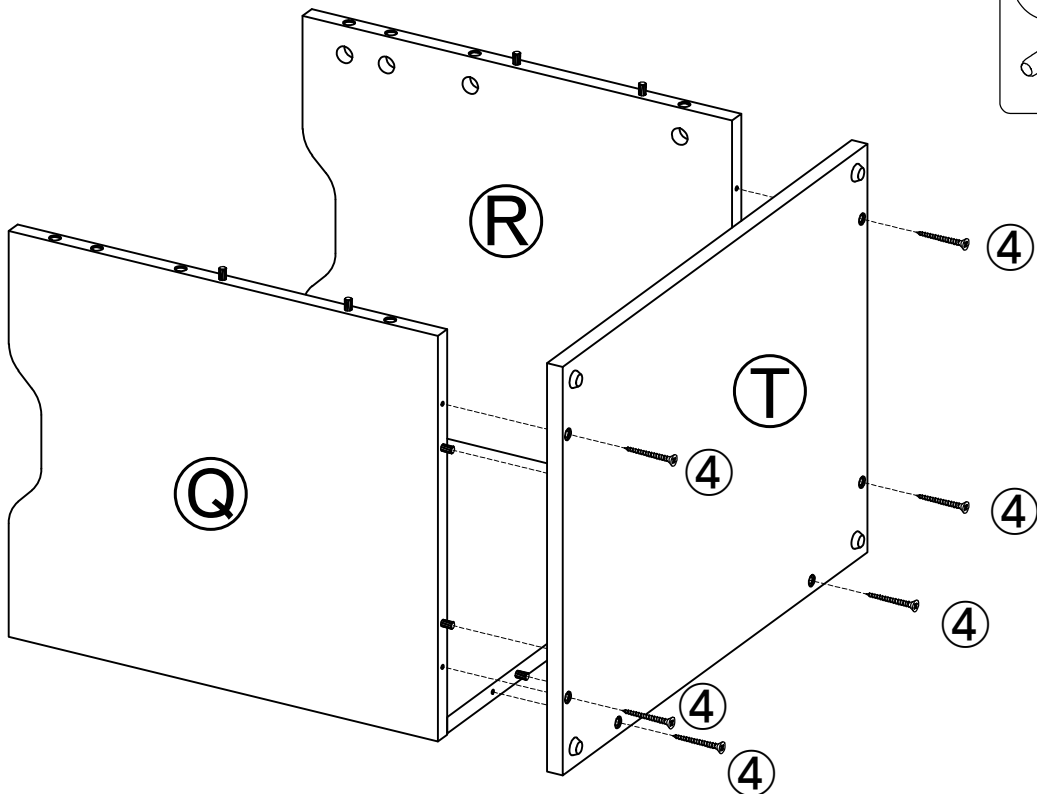

# Assembly Step

## Step 25

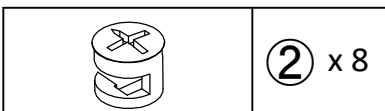
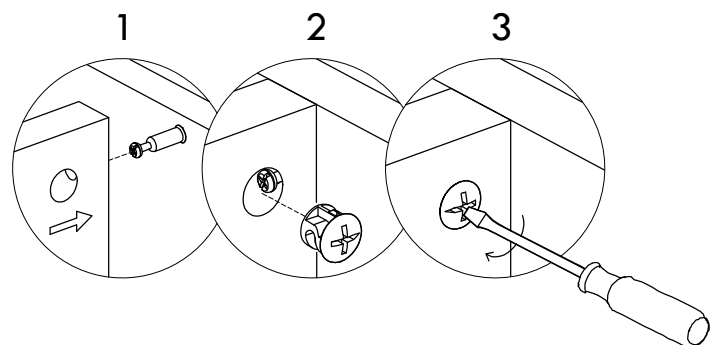
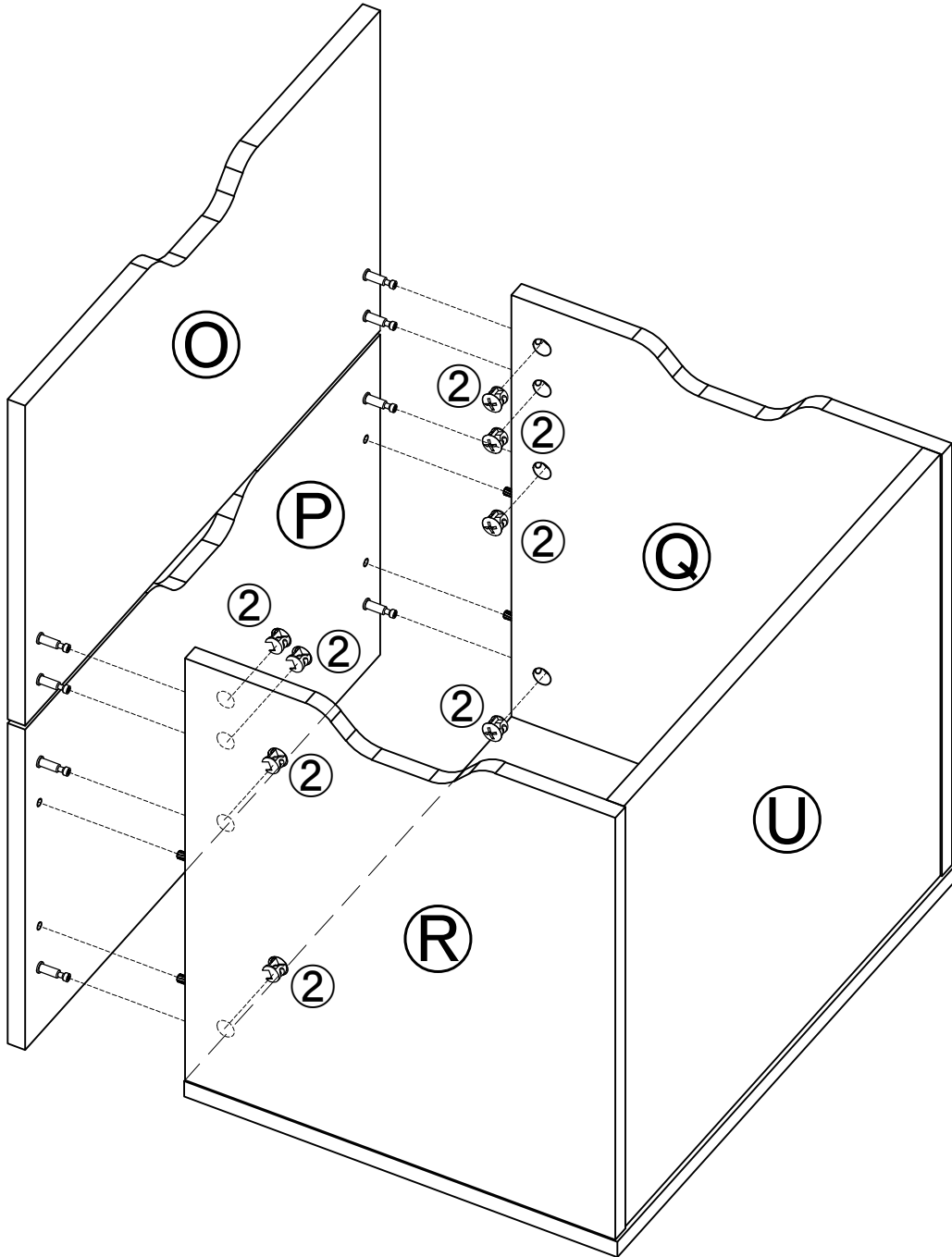
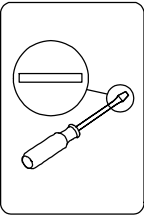

# Assembly Step

## Step 26

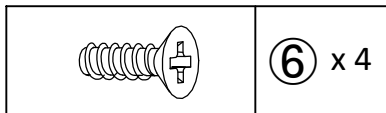
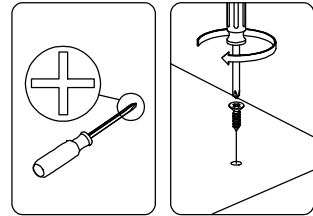
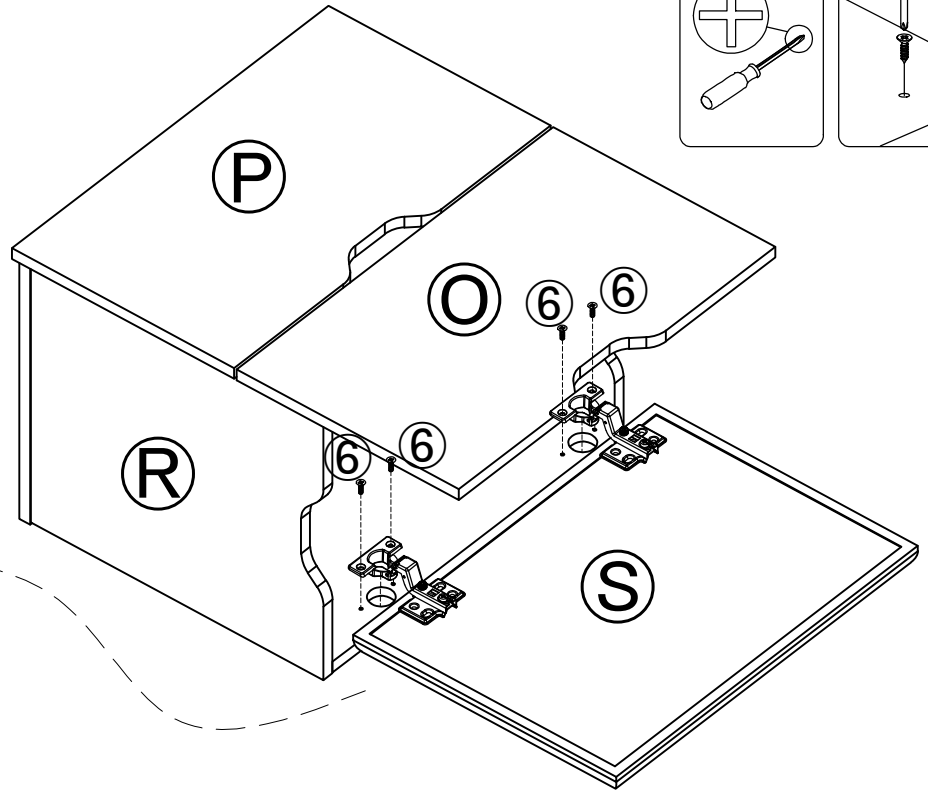
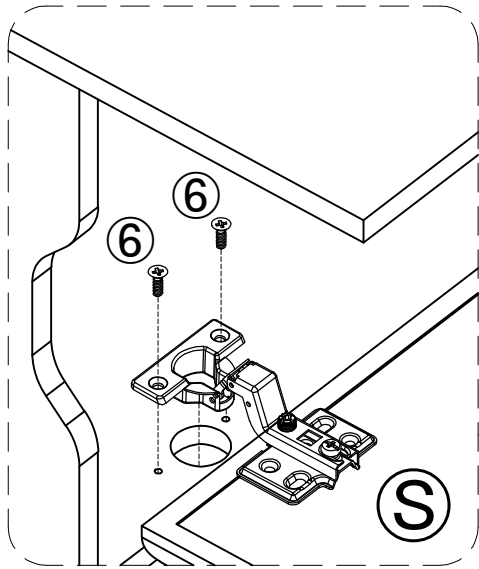

## Step 27

If necessary, adjust hinges to properly align doors as shown below.

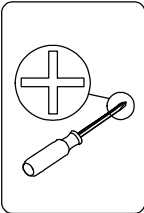

Adjusting possibilities

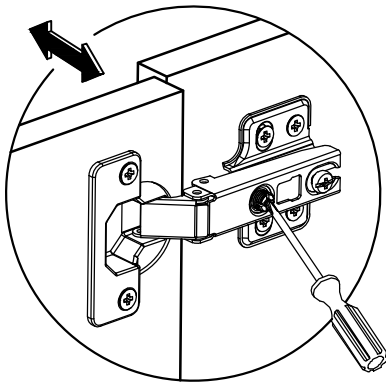

Lateral Adjustment

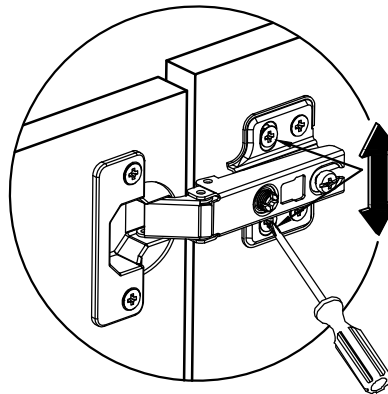

Vertical adjustment

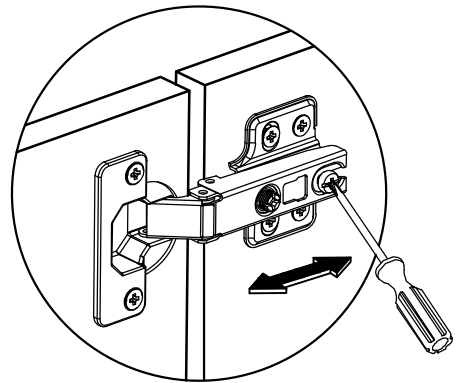

Forward/backwards adjustment

# Assembly Step

## Step 28

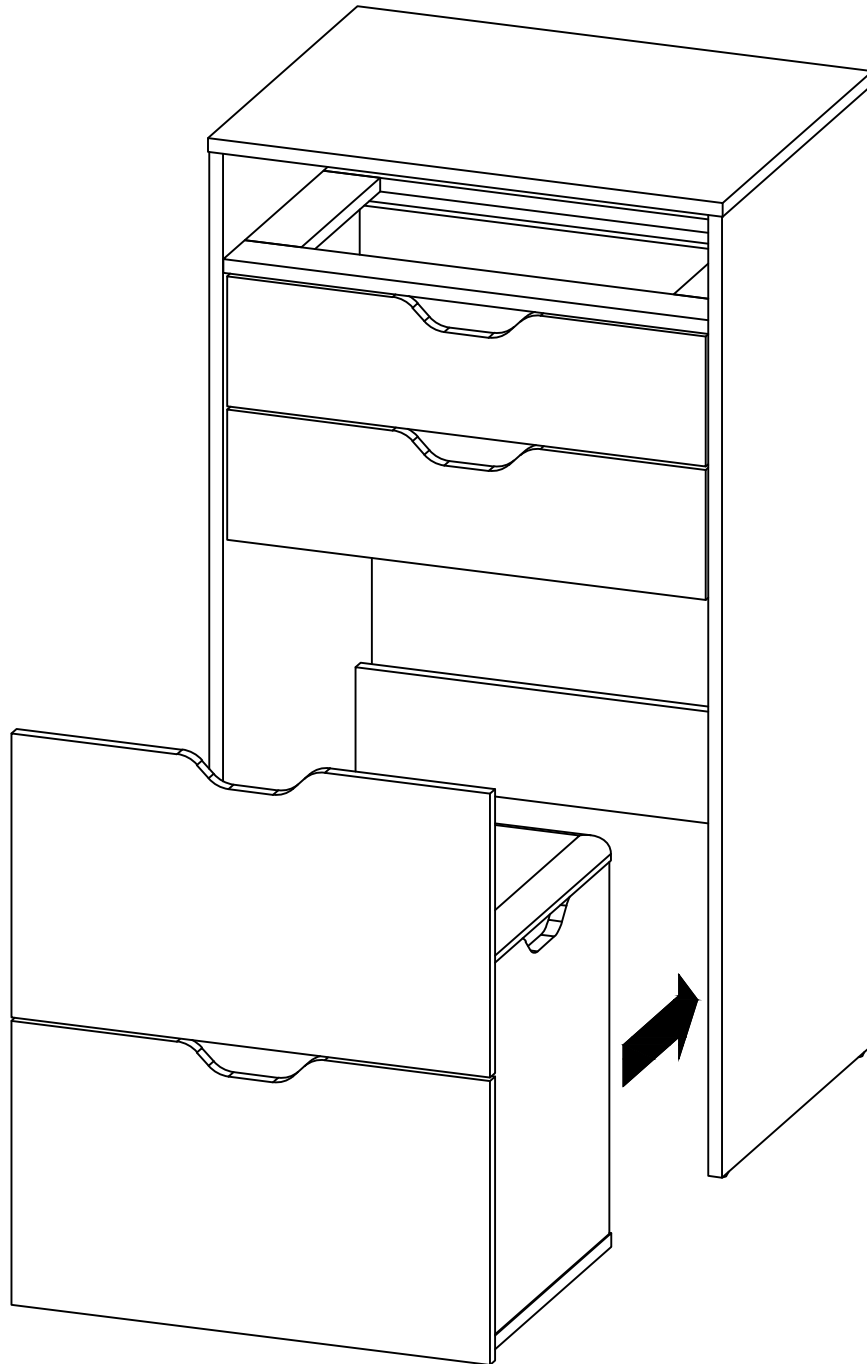

# Assembly Step

## Step 29

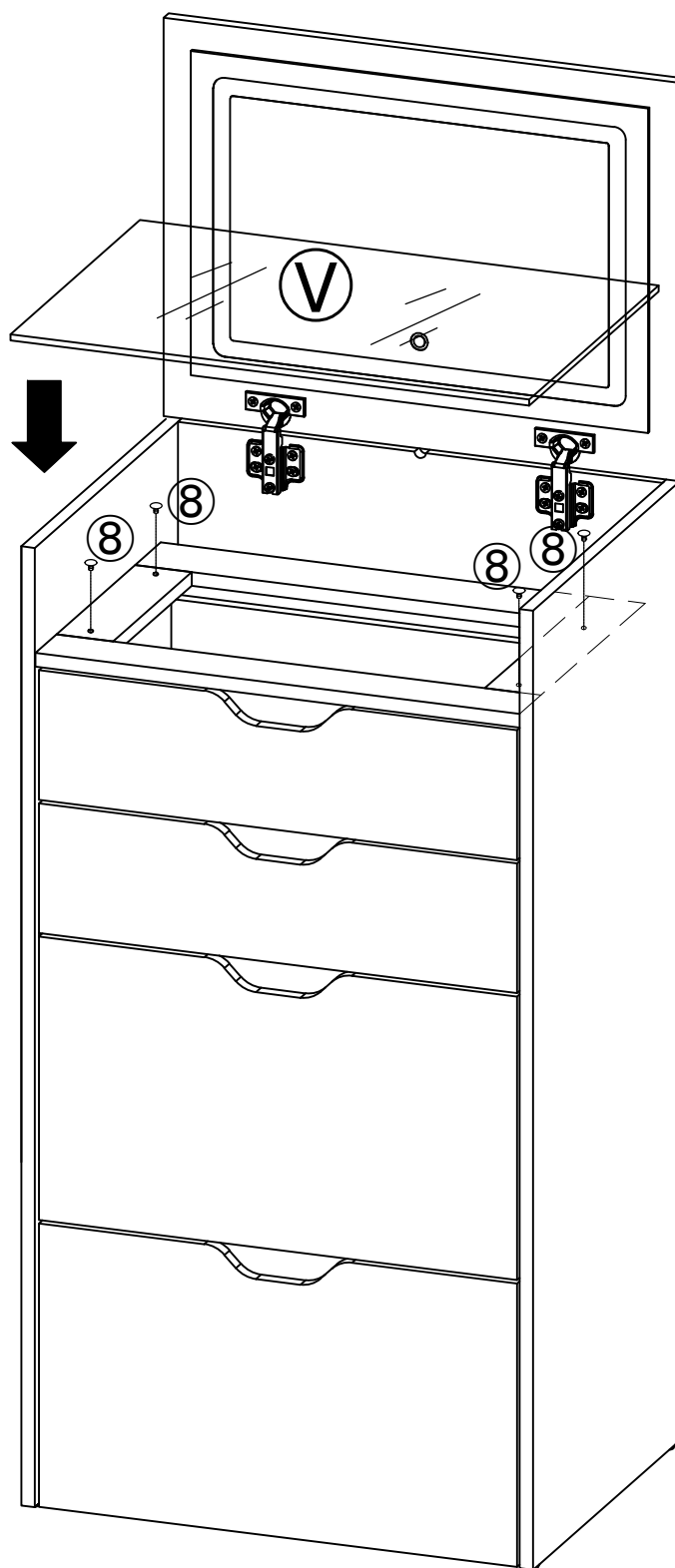

# Assembly Step

## Step 30

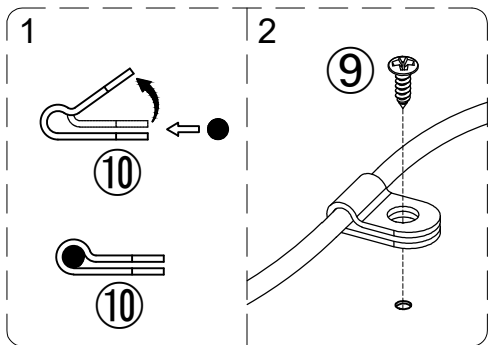
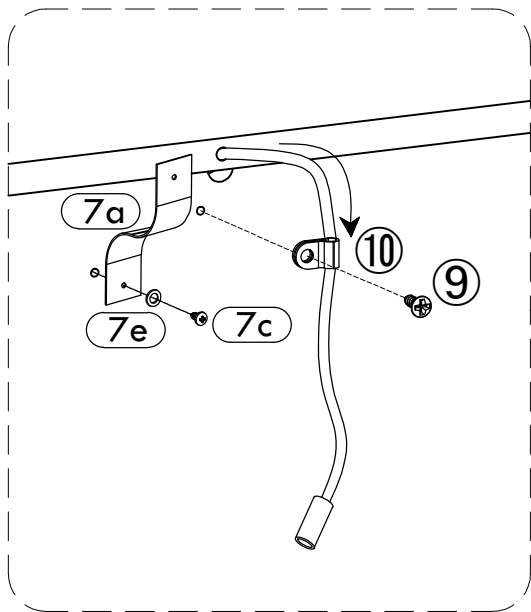
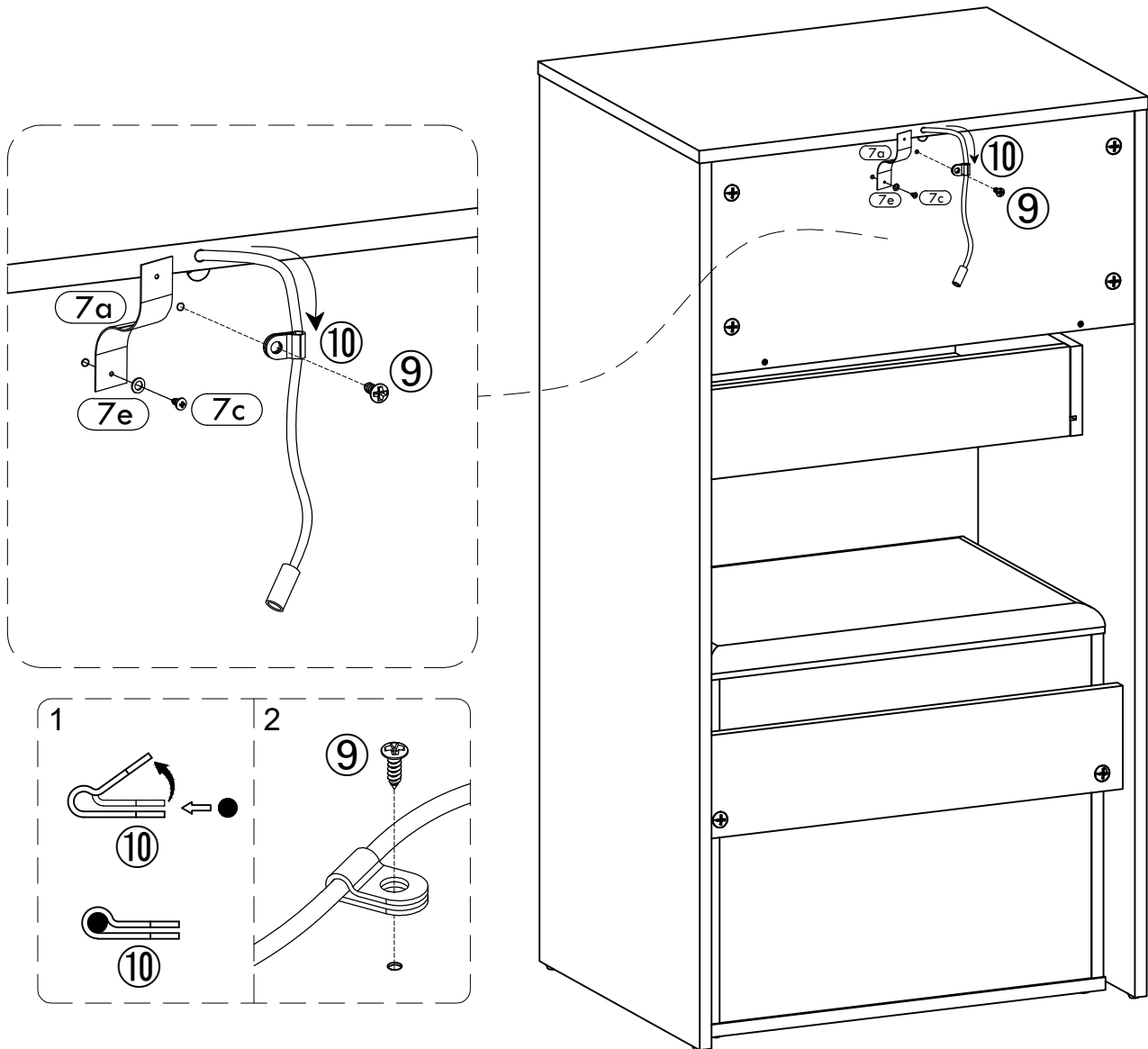
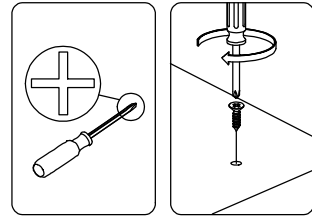

	9 x 1		7 x 1
	10 x 1		

# Assembly Step

## Step 31

