

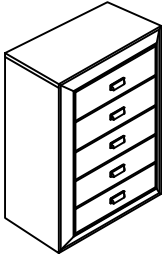

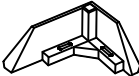

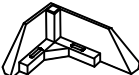

# ASSEMBLY INSTRUCTIONS

REVISION : A

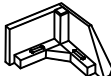
NO	PARTS LIST		
A	Chest		1
B	FR Front Right Feet		1
C	FL Front Left Feet		1
D	BR Rear Right Feet		1
E	BL Rear Left Feet		1
HARDWARE LIST			
F	JCBC M6 x 35mm		8
G	Spring Washer		8
H	Washer $\text{Ø}\frac{1}{4}$ " x 20mm		8
I	Allen Key M4		1

## STEP 1

Take out Assembly Instruction sheet, Hardware Pack and Feet Packaging from the Drawer which marked with the rope.

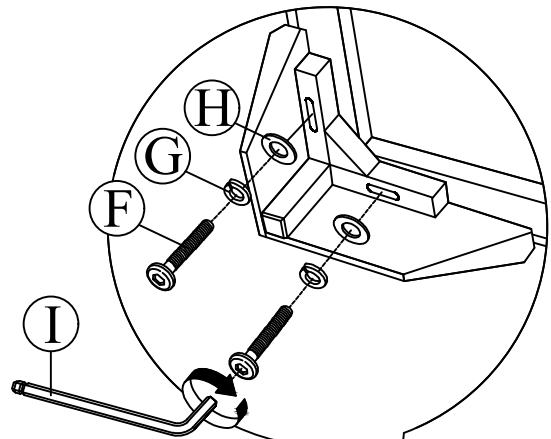
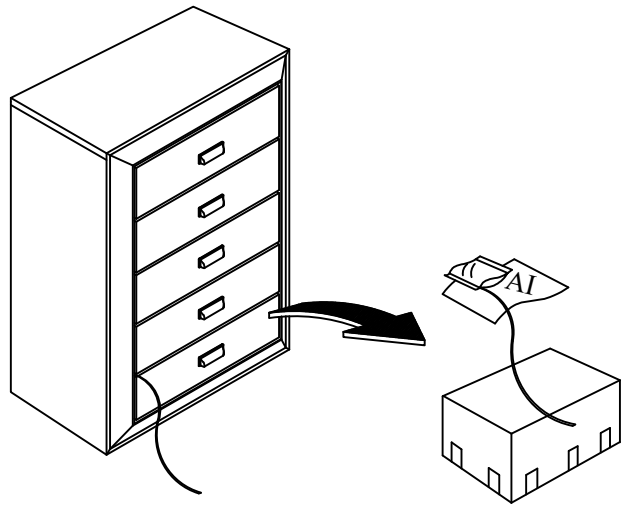

"FR" & "FL" Marking at bottom of the Unit & top of the Leg

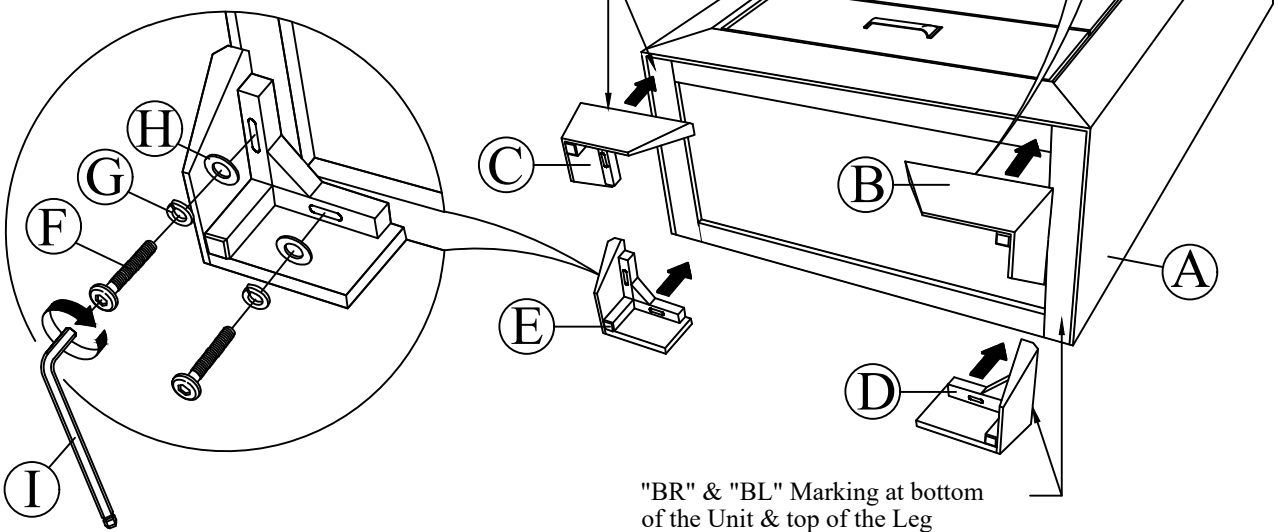

"BR" & "BL" Marking at bottom of the Unit & top of the Leg

## STEP 2

Align & fasten feet (B),(C),(D) and (E) to Unit according to the position left and right follow the label correctly using bolt (F), lock washer (G) and flat washer (H) and fully tighten with Allen Key (I).