



ASSEMBLY INSTRUCTIONS

Pour le français, voir la page 2. Para el español, ver la página 3.

11' x 13.5'

STORAGE SHED

MODEL 6415

BEFORE ASSEMBLY:

- Assemble on a level platform.
- At least 3 people for setup recommended.



FOR DOMESTIC USE ONLY!

IMPORTANT, RETAIN FOR FUTURE REFERENCE: READ CAREFULLY.

TOOLS REQUIRED

(Not included—unless otherwise indicated*)



TABLE OF CONTENTS

Icon legend.....	4
Warnings & notices.....	5
Platform construction.....	6
Truss assembly.....	11
Gable assembly.....	16
Door assembly.....	18
Domed skylight assembly.....	27
Floor assembly.....	31
Wall assembly.....	35
Truss installation.....	40
Shelving installation.....	47
Parts identifier.....	49
Door & gable installation.....	60
Trim installation.....	68
Roof assembly.....	71
Window installation.....	80
Pegboard strip installation.....	87
Door alignment.....	89
Shed anchoring.....	92
Cleaning & care.....	99
Registration.....	100
Warranty.....	101

QUESTIONS?

Call:
1-800-225-3865
 (English, French, Spanish)

CONTACT LIFETIME® CUSTOMER SERVICE:

Live Chat:
www.lifetime.com/customerservice/home
 (click on "LIVE CHAT" tab)

For Customer Service in mainland
 Europe and the United Kingdom, E-mail:
csinternational@lifetime.com

Model Number: **6415**
 Product ID:



INSTRUCTIONS D'ASSEMBLAGE

For English, see page 1. Para el español, ver la página 3.

ABRI EXTÉRIEUR DE 3,4 m x 4,1 m

MODÈLE n° 6415

AVANT L'ASSEMBLAGE :

- Assembler sur une plat-forme nivelée.
- Nous recommandons, au moins, 3 adultes pour l'assemblage.



POUR L'USAGE DOMESTIQUE SEULEMENT !

IMPORTANT, CONSERVER POUR RÉFÉRENCE : LIRE AVEC PRUDENCE !

OUTILS REQUIS

(Non inclus — sauf indication contraire*)



SOMMAIRE

Légende des icônes.....	4
Avertissements et avis.....	5
Assemblage de la plate-forme.....	6
Assemblage des fermes.....	11
Assemblage des pignons.....	16
Assemblage des portes.....	18
Assemblage des lucarnes.....	27
Assemblage du plancher.....	31
Assemblage des murs.....	35
Instalación des fermes.....	40
Installation du rayonnage.....	47
Identificateur de pièces.....	49
Installation des portes.....	60
Installation des moulures.....	68
Assemblage du toit.....	71
Installation des fenêtres.....	80
Installation des organisateurs.....	87
Alignement des portes.....	89
L'ancrage de l'abri.....	92
Nettoyage et entretien.....	99
Enregistrement.....	100
Garantie.....	102

QUESTIONS ?

Composer le
1-800-225-3865
(anglais, français, espagnol)

CONTACTER AUX SERVICES À LA CLIENTÈLE LIFETIME® :

Entretien en direct:
www.lifetime.com/customerservice/home
(cliquer sur la languette « LIVE CHAT »)

Pour les services à la clientèle du
continent européen, E-mail:
csinternational@lifetime.com

N° de pièce : 6415
Référence du produit :



INSTRUCCIONES DE ENSAMBLAJE

For English, see page 1. Pour le français, voir la page 2.

CASETA EXTERIOR DE 3,4 m x 4,1 m

MODELO n° 6415

ANTES DE ENSAMBLAR:

- Ensamblar en una plataforma nivelada.
- Recomendamos, al menos, 3 adultos para el ensamblaje.



¡SÓLO PARA USO DOMÉSTICO!

¡IMPORTANTE, GUARDAR PARA FUTURA REFERENCIA: LEER CUIDADOSAMENTE!

INSTRUMENTAL REQUERIDO

(No incluido, salvo indicación contratia*)



ÍNDICE

Leyenda de íconos.....	4
Advertencias y avisos.....	5
Ensamblaje de la plataforma.....	6
Ensamblaje de las cerchas.....	11
Ensamblaje de las fachadas.....	16
Ensamblaje de las puertas.....	18
Ensamblaje de los tragaluces.....	27
Ensamblaje del piso.....	31
Ensamblaje de los muros.....	35
Instalación de las cerchas.....	40
Instalación de la estantería.....	47
Identificador de piezas.....	49
Instalación de las puertas.....	60
Instalación de las molduras.....	68
Ensamblaje del tejado.....	71
Instalación de las ventanas.....	80
Instalación de los organizadores.....	87
Alineación de las puertas.....	89
Anclaje de la caseta.....	92
Limpieza y cuidado.....	99
Registro.....	100
Garantía.....	103

¿PREGUNTAS?

PONERSE EN CONTACTO CON LOS SERVICIOS DE CLIENTES LIFETIME®:

Llame al:
1-800-225-3865
(Inglés, francés, español)

Chat Live:
www.lifetime.com/customerservice/home
(clicquee en la lengüeta «LIVE CHAT»)

Para el servicio a clientes en el continente europeo, correo electrónico:
csinternational@lifetime.com

Numero di modello: **6415**
Numero di prodotto:



ICON LEGEND / LÉGENDE DES ICÔNES / SIGNIFICADO DE LOS ÍCONOS



- Indicates special heed should be taken when reading.
- Indique qu'une attention spéciale doit être portée à la lecture.
- Indica que uno debe prestar atención al leer.

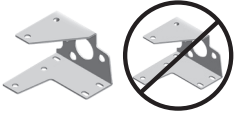

- Indicates the parts/no parts required for a section.
- Indique les pièces à utiliser/qu'aucune pièce n'est requise pour une section.
- Indica las piezas que se usarán/que no necesitan en una sección.



- Indicates the hardware to be used for a section.
- Indique la quincaillerie à utiliser pour une section.
- Indica los artículos de ferretería que se usarán para una sección.



- Indicates no hardware required for a specific page or section.
- Indique qu'aucun matériel n'est requis pour une page précise.
- Indica que no se necesitan los artículos de ferretería para una página específica.



- Indicates the tools to be used for a section.
- Indique les outils à utiliser pour une section.
- Indica las herramientas que se utilizarán para una sección.



- Indicates to use/not use an electric drill for a specific step.
- Indique quand utiliser une/que ne pas utiliser de perceuse électrique pour une étape précise.
- Indica la utilización de/que no utilizar un taladro eléctrico para un paso específico.



- These nuts are centerlock nuts. They are designed to be tight; therefore, they will be harder to tighten. Tighten until flush with the metal or plastic.
- Ces écrous sont des écrous de blocage central. Ils sont conçus pour être serrés; de ce fait, ils seront plus difficiles à resserrer. Serrer jusqu'à ce qu'ils soient au ras du métal ou du plastique.
- Estas tuercas son tuercas de bloqueo central. Están diseñadas para estar apretadas; por lo tanto, serán más difíciles de apretar. Apriételas hasta que estén al ras del metal o plástico.



- Indicates the number of adults required to perform a specific step, e.g., 2, 3, 4, etc.
- Indique le nombre d'adultes requis pour effectuer une étape spécifique, p. ex., 2, 3, 4, etc.
- Indica el número de adultos requeridos para realizar un paso específico, p.ej., 2, 3, 4, etc.

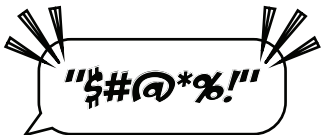

- Indicates a specific step is more difficult to complete.
- Indique qu'une étape spécifique est plus difficile à exécuter.
- Indica que un paso específico es más difícil de realizar.





WARNINGS & NOTICES / AVERTISSEMENTS ET AVIS / ADVERTENCIAS Y AVISOS



English:

- **Failure to follow these warnings may result in serious injury or property damage and will void warranty.**
- To ensure safety, do not attempt to assemble this product without following the instructions carefully.
- Consult all local building codes to verify if the shed requires a building permit.
- Verify the platform foundation is completely level before assembling the shed.
- Be aware that plastic pieces can be damaged by overtightening the screws. To avoid damage, we strongly recommend the use of a drill with a low torque setting. A #2 Phillips screwdriver may also be used.
- Three capable adults are required for assembly.
- All who participate in the assembly process should wear safety glasses throughout the assembly.
- If using a ladder during assembly, use extreme caution.
-  In heavy snowfall areas, we recommend removing snow from the roof. Remove the snow from the roof when the depth of snow equals the length of your hand.
- Do not use or store hot objects near the product.
- Proper and complete assembly are essential to reduce the risk of accident or injury.
- When drilling through metal, beware of burrs, shavings and other sharp edges.
- During and after assembly, do not slide or lift the shed by pushing up on the roof. Move the shed by pushing on the corner panels only.
- Failure to anchor the shed may result in property damage and/or personal injury. The last section, *Shed Anchoring*, in this manual shows the hardware you will need to complete the anchoring. You can find the hardware at your local hardware store.
- **Most injuries are caused by misuse and/or not following instructions. Use caution when using this product.**

Français :

- **Ne pas suivre ces avertissements peut entraîner des blessures graves ou des dommages à la propriété et annulera la garantie.**
- Afin d'assurer la sécurité, ne pas tenter d'assembler ce produit sans suivre attentivement les instructions.
- Consulter tous les codes du bâtiment afin de vérifier si l'abri nécessite un permis de construire.
- Vérifier que la fondation de la plate-forme est complètement à niveau avant l'assemblage de l'abri.
- Ne pas oublier que les pièces de plastique peuvent être endommagées en serrant trop les vis. Afin d'éviter les dommages, nous recommandons fortement l'utilisation d'une perceuse à faible couple. Un tournevis cruciforme n° 2 peut aussi être utilisé.
- Trois adultes en bonne condition physique sont nécessaires pour l'assemblage.
- Tout ceux qui participent au processus de l'assemblage doivent porter des lunettes de sécurité tout au long de l'assemblage.
- Si une échelle est utilisée pour l'assemblage, il faut être extrêmement prudent.
- Dans les zones de fortes tombées de neige, il est recommandé de dégager le toit. Enlever la neige du toit quand la profondeur est égale à la longueur de la main.
- Ne pas utiliser ou entreposer des objets très chauds près de ce produit.
-  Un bon assemblage complet est nécessaire pour réduire le risque d'accident ou de blessure.
-  En perçant le métal, faire attention aux bavures, copeaux et autre bords aiguisés.
- Pendant et après l'assemblage, ne pas faire glisser ou soulever l'abri en poussant le toit vers le haut. Déplacer l'abri en poussant les panneaux muraux angulaires seulement.
- Si vous n'ancrez pas votre abri, des dommages à la propriété et/ou des blessures peuvent en résulter. La dernière section, *Ancrage de l'abri*, de ce manuel indique les matériaux nécessaires pour l'ancrage. Les matériaux se trouvent dans la quincaillerie locale.
- **La majorité des blessures sont causées par une mauvaise utilisation et/ou le non suivi des instructions. Être prudent en utilisant ce produit.**

Español:

- **No seguir estas advertencias puede resultar en lesiones graves o daños a la propiedad y anulará la garantía.**
- A fin de garantizar la seguridad, no intentar ensamblar este producto sin seguir cuidadosamente las instrucciones.
- Consultar todos los códigos de construcción locales para verificar si el cobertizo requiere un permiso de construcción.
- Verificar que el concreto de la plataforma esté nivelado completamente antes de ensamblar el cobertizo.
- Tener en cuenta que las piezas de plástico pueden dañarse si los tornillos se aprietan de más. A fin de evitar daños, lo exhortamos a que use un taladro con función de torque bajo. También puede usarse un desatornillador Phillips no. 2.
- Se necesitan tres adultos para el ensamble.
- Todos los que participan en el proceso de ensamble debe usar anteojos de seguridad durante todo el ensamble.
- Si se usa una escalera durante el ensamblado, es preciso tener cuidado.
- En áreas de nevadas fuertes, recomendamos retirar la nieve del techo. Quitar la nieve del tejado cuando la profundidad de ella es igual a la longitud de la mano.
- No usar ni guardar objetos calientes cerca del producto.
-  El ensamblaje correcto y completo son esenciales para reducir el riesgo de accidente o lesión.
-  Al perforar metal, tenga cuidado las rebabas, virutas y otros bordes afilados.
- Durante y después del ensamblaje, no deslizar ni levantar el cobertizo para empujar en el tejado. Mover el cobertizo para empujar los paneles murales angulares solamente.
- No anclar el cobertizo puede resultar en daños a la propiedad y/o en lesiones personales. La última sección, *Anclaje de el cobertizo*, en este manual muestra el herraje necesaria para terminar el anclaje. Se encuentra el herraje en la ferretería local.
- **La mayoría de las lesiones suceden a causa del mal uso y/o por no seguir las instrucciones. Tener precaución al usar este producto.**



• You must provide a platform on which to assemble your shed. Proper building permit documentation may be required in your neighborhood. Consult all local building codes prior to assembling the shed. Before beginning assembly, you must pour or construct a platform. There are two types:

- Concrete
- Wood Frame

Select the type, but know the surface must be leveled and flat before installation. If the surface is not properly leveled and flat, the shed will not assemble correctly. Proper surface leveling will save you time in the long run, so please do not ignore this step. **We recommend a Concrete platform. It will be the most durable and long-lasting choice. The platform you choose must be built above ground in order to avoid water pooling inside the shed. All lumber must be rated for outdoor use!**



• Il faut construire une plate-forme sur laquelle vous devez assembler votre abri. Il est possible que votre quartier exige une documentation visant les permis de construire. Consultez tous les codes du bâtiment locaux, ainsi que les décrets des villes et comtés, pour vérifier que la construction de l'abri extérieur n'exige pas un permis de construire. Avant de commencer l'assemblage, il faut couler ou construire une plate-forme. Il y a deux styles :

- Béton
- Cadre à bois

Sélectionnez le style, mais sachez que la surface d'installation doit être de niveau et plate. Si la surface n'est pas correctement de niveau et plate, l'assemblage de l'abri ne se fera pas correctement. Vous gagnerez du temps sur le long terme grâce à une surface bien de niveau, ne négligez donc pas cette étape. **Nous recommandons une plate-forme en Béton. Ce choix sera le plus durable. La plate-forme que vous choisissez doit être construite au-dessus du sol afin d'éviter l'accumulation d'eau à l'intérieur de l'abri. Tous le bois d'oeuvre doit être approuvé pour l'usage à l'extérieur!**



• Es preciso construir una plataforma sobre la cual usted debe ensamblar su caseta. Puede suceder que en su vecindario se requiera la documentación apropiada de un permiso de construcción. Consulte todos los códigos locales de construcción y los reglamentos de la ciudad y el municipio para asegurarse de que la construcción de la caseta no requiere un permiso de construcción. Antes de comenzar el ensamble, es necesario verter o construir una plataforma. Hay dos clases:

- Concreto
- Armazón de madera

Seleccione la clase, mas sepa que la superficie debe estar nivelada y plana antes de comenzar el ensamble. Si la superficie no está nivelada y plana de manera adecuada, el cobertizo no podrá armarse correctamente. La nivelación de la superficie le ahorrará tiempo de trabajo, por lo tanto, le pedimos que no ignore este paso. **Recomendamos una plataforma hecho de concreto. Será la elección más perdurable. La plataforma debe ser construida arriba del suelo para evitar el flujo de agua dentro de la caseta. ¡Toda la madera debe estar clasificada para el uso externo!**

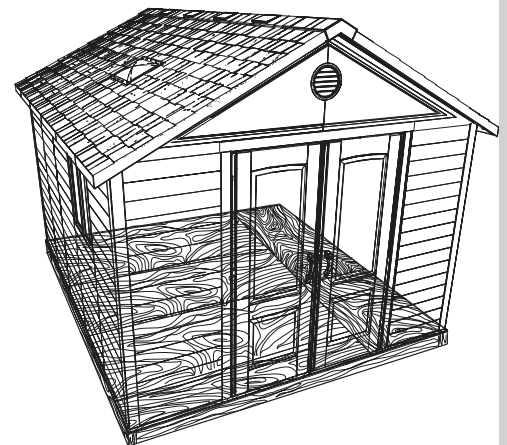
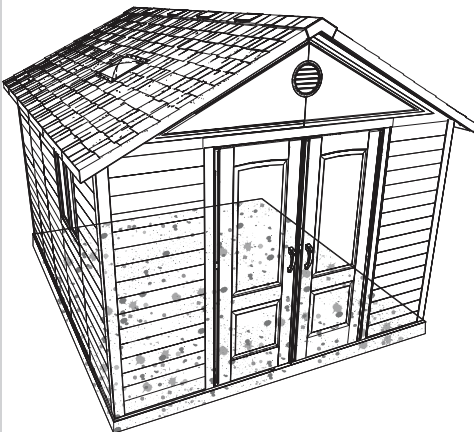

► SECTION 1 (CONTINUED) / SECTION 1 (SUITE) / SECCIÓN 1 (CONTINUACIÓN)

CONCRETE REQUIRED / BÉTON REQUIS / CONCRETO REQUERIDO



1.5 yd³ (≈1,15 m³)

1.1

CONCRETE PLATFORM / PLATE-FORME EN BÉTON / PLATAFORMA DE CONCRETO

- The concrete should be approximately 4" (≈10,2 cm) thick. The actual dimensions of the shed, at its widest and longest points, are 132" x 162" (≈3,35 m x ≈4,12 m). Ensure you select a site that will accommodate these measurements. **The floor dimensions are a bit smaller than those of the roof; therefore, you will need to build a level surface of 123 1/2" x 153 1/2" (≈3,14 m x ≈3,90 m).**
- Le béton doit être un épaisseur de ≈10,2 cm (4 po). Les dimensions réelles de votre abri, aux points les plus large et long, sont ≈3,35 m x ≈4,12 m (132 po x 162 po). Assurez-vous de sélectionner un site qui accommodera ces dimensions. **Les dimensions du plancher de votre abri sont plus petites que le toit; ensuite, il faut créer une surface nivelée de ≈3,14 m x ≈3,90 m (123 1/2 po x 153 1/2 po).**
- El concreto debe tener, por lo menos, ≈10,2 cm (4 in.) de espesor. Las dimensiones reales de la caseta, a sus puntos más ancho y largo, son ≈3,35 m x ≈4,12 m (132 in. x 162 in.). Asegúrese de seleccionar un sitio que acomodará estas medidas. **Las dimensiones del piso de la caseta son más pequeñas que el tejado; entonces, necesitará crear una superficie nivelada de ≈3,14 m x ≈3,90 m (123 1/2 in. x 153 1/2 in.).**

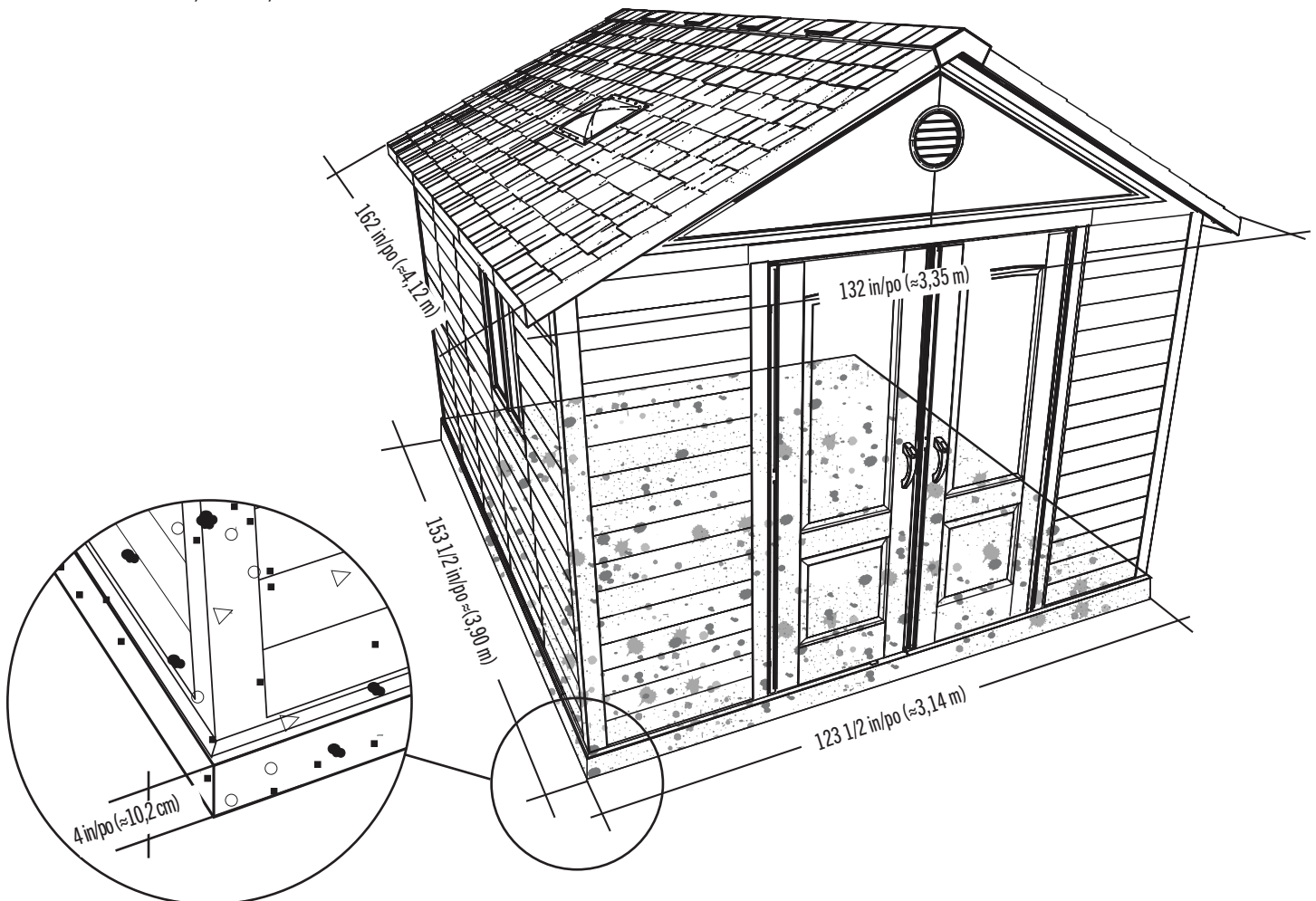

► SECTION 1 (CONTINUED) / SECTION 1 (SUITE) / SECCIÓN 1 (CONTINUACIÓN)

WOOD REQUIRED / BOIS REQUIS / MADERA REQUERIDA

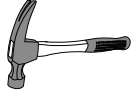

1.2

WOOD PLATFORM / PLATE-FORME EN BOIS / PLATAFORMA DE MADERA

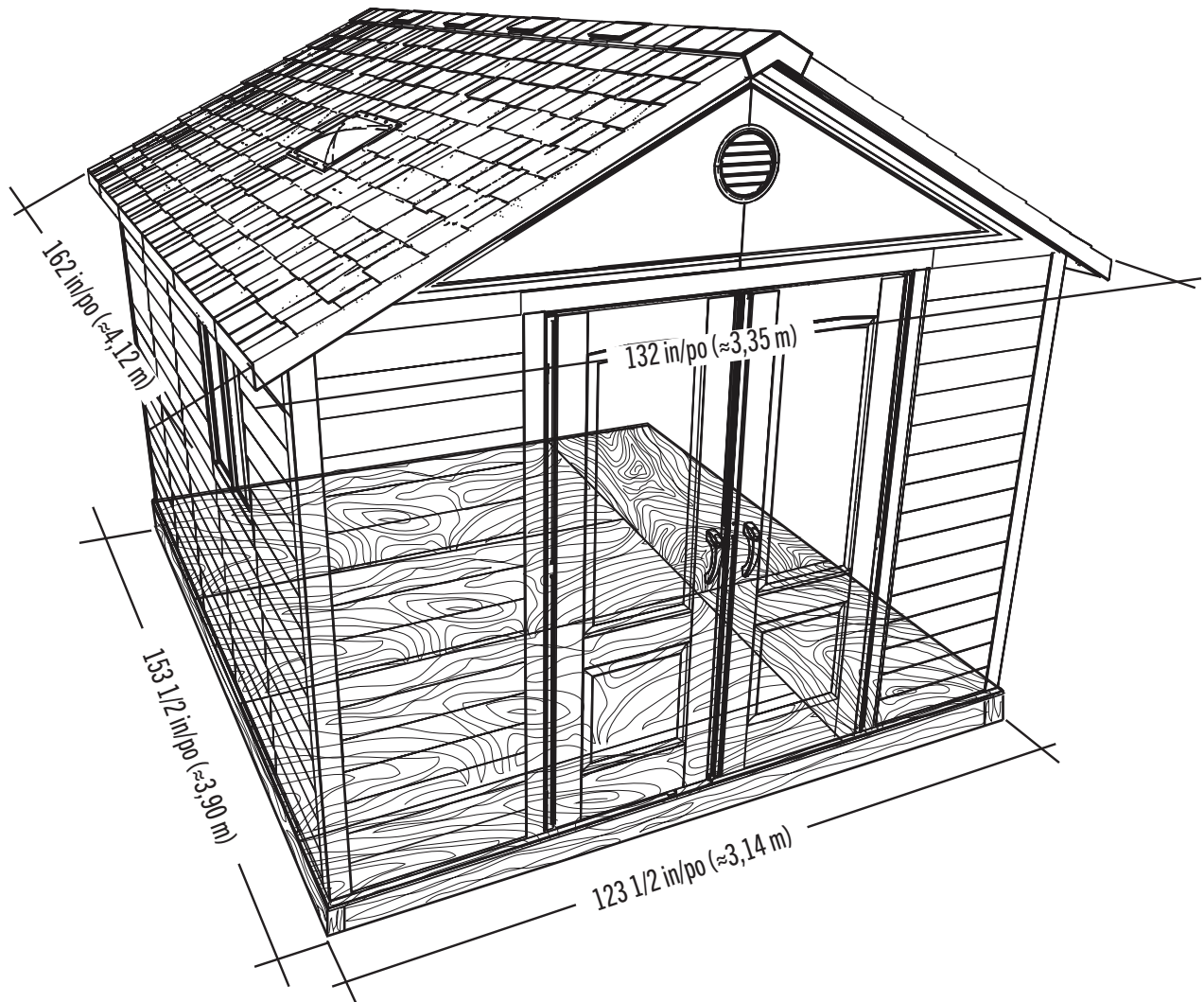

► SECTION 1 (CONTINUED) / SECTION 1 (SUITE) / SECCIÓN 1 (CONTINUACIÓN)

TOOLS, PARTS, AND HARDWARE REQUIRED / OUTILS, PIÈCES, ET QUINCAILLERIE REQUIS / INSTRUMENTAL, PIEZAS, Y HERRAJE REQUERIDOS

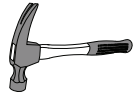

2 in/po x 4 in/po x 153 1/2 in/po (≈3,90 m) (x2)



2 in/po x 4 in/po x 120 1/2 in/po (≈3,06 m) (x11)

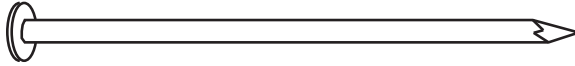

16d 3 1/2 in/po (16d x ≈8,89 cm) (x44)

1.2.1

WOOD PLATFORM / PLATE-FORME EN BOIS / PLATAFORMA DE MADERA

- Ensure all lumber is treated and approved for outdoor use. Build frame to 123 1/2" x 153 1/2" (≈3,14 m x ≈3,90 m) (**outside dimensions**).
- Vérifiez que votre bois d'œuvre à été traité et approuvé pour l'utilisation à l'extérieur. Construisez un cadre de ≈3,14 m x ≈3,90 m (123 1/2 po x 153 1/2 po) (**dimensions extérieures**).
- Asegure que use madera tratada y aprobada para el uso externo. Construya el armazón a ≈3,14 m x ≈3,90 m (123 1/2 in. x 153 1/2 in.) (**dimensiones exteriores**).

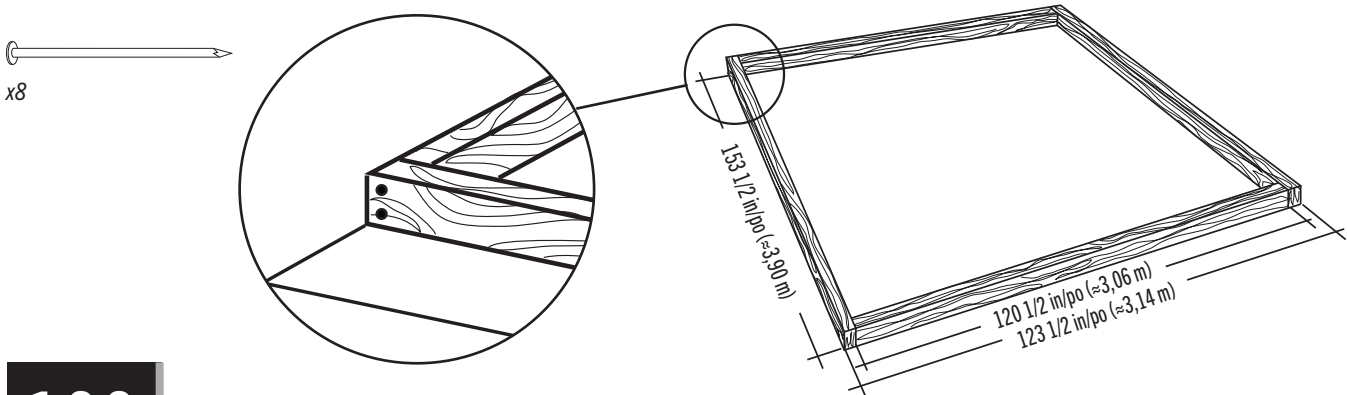

1.2.2

- Nail the first inner stud 16" (≈40,1 cm) from the front corner. Then nail the rest 16" (40,1 cm) on center.
- Clouez le premier montant intérieur ≈40,1 cm (16 po) de l'angle avant. Ensuite, clouez les montants intérieurs restants 40,1 cm (16") de centre à centre du montant intérieur précédent.
- Clave el primer montante interior ≈40,1 cm (16 in.) del ángulo delantero. Entonces, clave los montantes interiores restantes ≈40,1 cm (16 in.) a partir del centro del montante interior anterior.

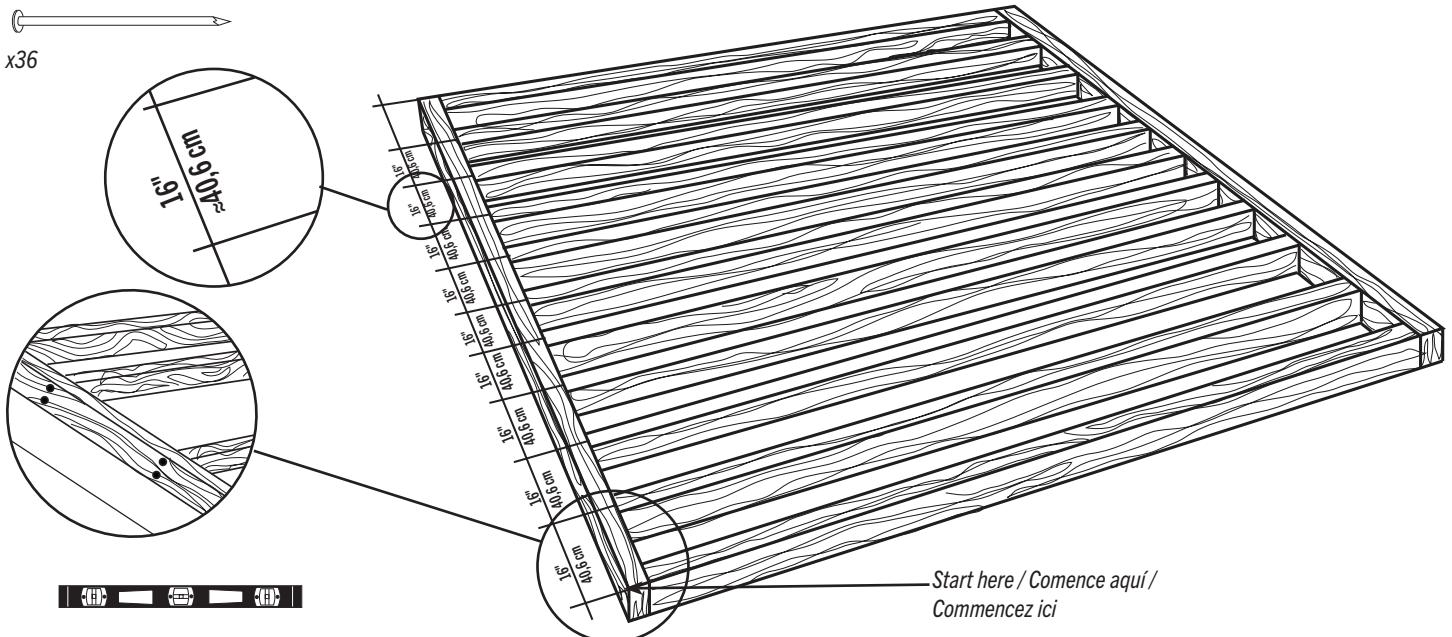

SECTION 1 (CONTINUED) / SECTION 1 (SUITE) / SECCIÓN 1 (CONTINUACIÓN)

TOOLS, PARTS, AND HARDWARE REQUIRED / OUTILS, PIÈCES, ET QUINCAILLERIE REQUIS / INSTRUMENTAL, PIEZAS, Y HERRAJE REQUERIDOS

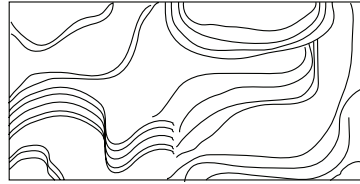
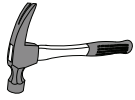

48 in/po x 96 in/po x 3/4 in/po
(≈1,22 m x ≈2,44 m x ≈19 mm) (x3)

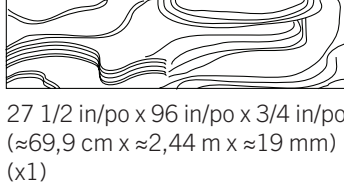

27 1/2 in/po x 96 in/po x 3/4 in/po
(≈69,9 cm x ≈2,44 m x ≈19 mm) (x1)



27 1/2 in/po x 57 1/2 in/po x 3/4 in/po
(≈69,9 cm x ≈1,46 m x ≈19 mm) (x1)

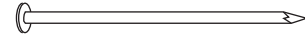

8d 2 1/2 in/po
(8d x ≈6,35 cm) (x76)

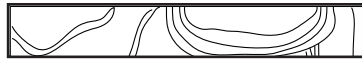

9 1/2 in/po x 96 in/po x 3/4 in/po
(≈24,1 cm x ≈2,44 m x ≈19 mm) (x1)

1.2.3

- Square the frame, measuring from corner to corner. **Measurement A & B should be about the same length.**
- Carrez le cadre en mesurant d'angle à angle. **La mesure « A » et « B » doivent être à peu près la même longueur.**
- Cuadre el armazón midiendo de esquina a esquina. **La medida «A» y «B» deben ser aproximadamente el mismo largo.**

A = B

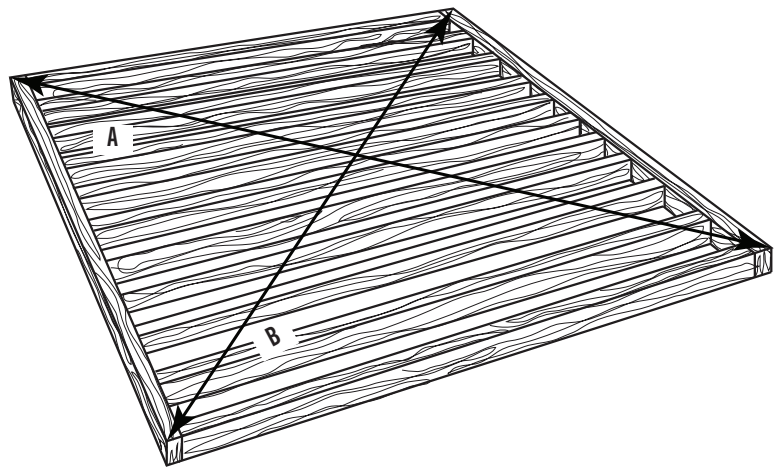

1.2.4

- Using nails, fasten the plywood to the frame. Then, drill 5/16" (≈8 mm) holes for drainage.
- Usando unos clavos, sujete el contrachapado al armazón. Entonces, taladre agujeros de 5/16 po (≈8 mm) para el drenaje.
- En utilisant des clous, attachez bien le contreplaqué au cadre. Ensuite, percez des trous de 5/16 in (≈8 mm) pour le drainage.

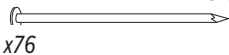

x76

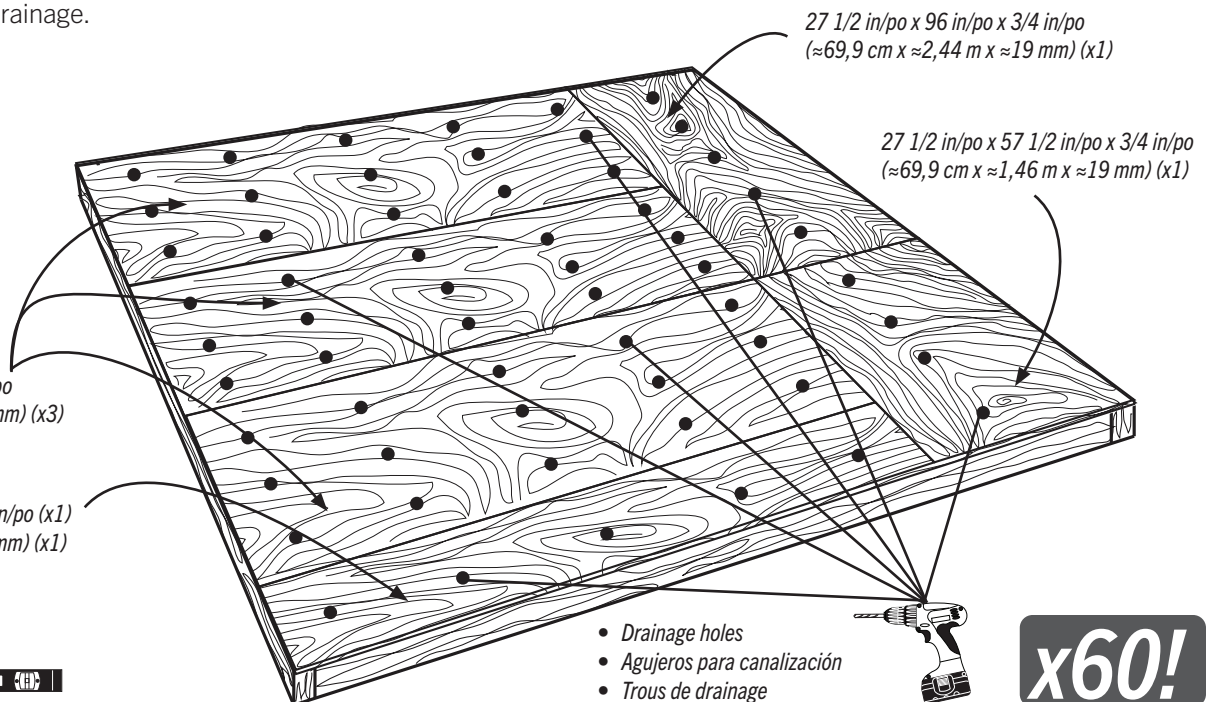

x60!

2

TRUSS ASSEMBLY / ASSEMBLAGE DES FERMES / ENSAMBLAJE DE LAS CERCHAS



HARDWARE REQUIRED / QUINCAILLERIE REQUISE / HERRAJE REQUERIDO

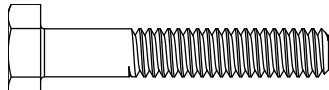

AAK (x50)



ADJ (x50)

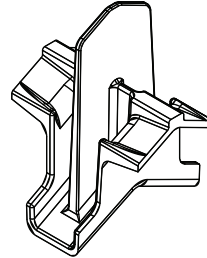

AIP (x5)

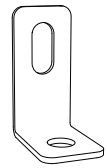

AHT (x10)



PARTS REQUIRED / PIEZAS REQUERIDAS / PIÈCES REQUISES

Metal parts / Pièces en métal / Piezas de metal

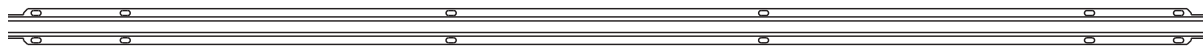

71 11/16 in/po (1,82 m)

AFH (x10)



79 1/2 in/po (2,02 m)

AFG (x5)



79 1/2 in/po (2,02 m)

AFQ (x10)

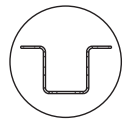

20 1/8 in/po (51 cm)

AFP (x10)



TOOLS REQUIRED / OUTILS REQUIS / INSTRUMENTAL REQUERIDO

(Not included—unless otherwise indicated*) / (Non inclus — sauf indication contraire*) / (No incluido, salvo indicación contratia*)



7/16 in/po (≈11 mm) (x2)

► SECTION 2 (CONTINUED) / SECTION 2 (SUITE) / SECCIÓN 2 (CONTINUACIÓN)

TOOLS AND HARDWARE REQUIRED / OUTILS ET QUINCAILLERIE REQUIS / INSTRUMENTAL Y HERRAJE REQUERIDOS

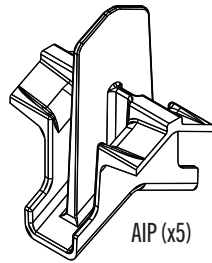

AIP (x5)

2.1

- Place a **truss connector (AIP)** down inside the ends of two **truss gutter channels (AFH)** as shown.
- Insérez un **connecteur de fermes (AIP)** dans les extrémités de deux **canaux de gouttière (AFH)** comme illustré.
- Coloque un **connector de canales (AIP)** en los extremos de dos **canalones de la cercha (AFH)** como se muestra.

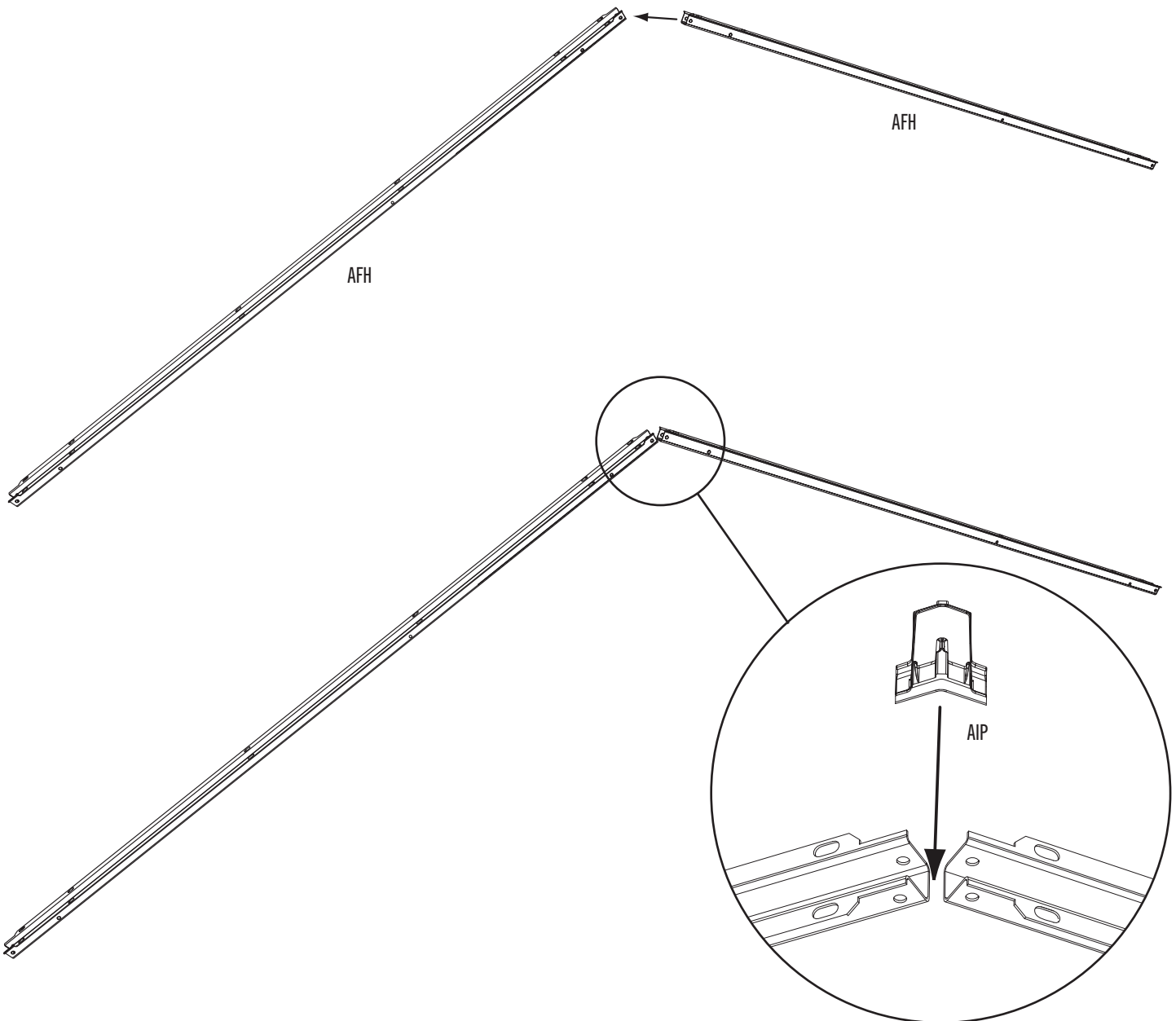

► SECTION 2 (CONTINUED) / SECTION 2 (SUITE) / SECCIÓN 2 (CONTINUACIÓN)

TOOLS AND HARDWARE REQUIRED / OUTILS ET QUINCAILLERIE REQUIS / INSTRUMENTAL Y HERRAJE REQUERIDOS



7/16 in/po (x2)
≈11 mm

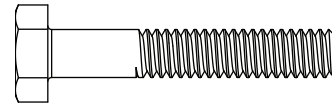

AAK (x10)



ADJ (x10)

2.2

- Insert two (2) bolts (AAK) through the first vertical truss brace (AFP), the holes in the truss gutter channels, over the truss connector, and out through the truss gutter channels and second vertical truss support (AFP). Secure with two cap nuts (ADJ). Do not overtighten the nuts.
- Insérez deux (2) boulons (AAK) à travers le premier support vertical (AFP), les trous dans les canaux de gouttière, over le connecteur de fermes, et à travers les canaux et le deuxième support vertical (AFP). Attachez-les bien à l'aide de deux écrous borgnes (ADJ). Ne pas trop serrer.
- Inserte dos (2) pernos (AAK) a través del primer soporte vertical (AFP), los agujeros en los canalones de la cercha, encima del conector de cerchas, y a través de los canalones de la cercha y el segundo soporte vertical (AFP). Sujételos con dos tuercas ciegas (ADJ). No apriete demasiado las tuercas.

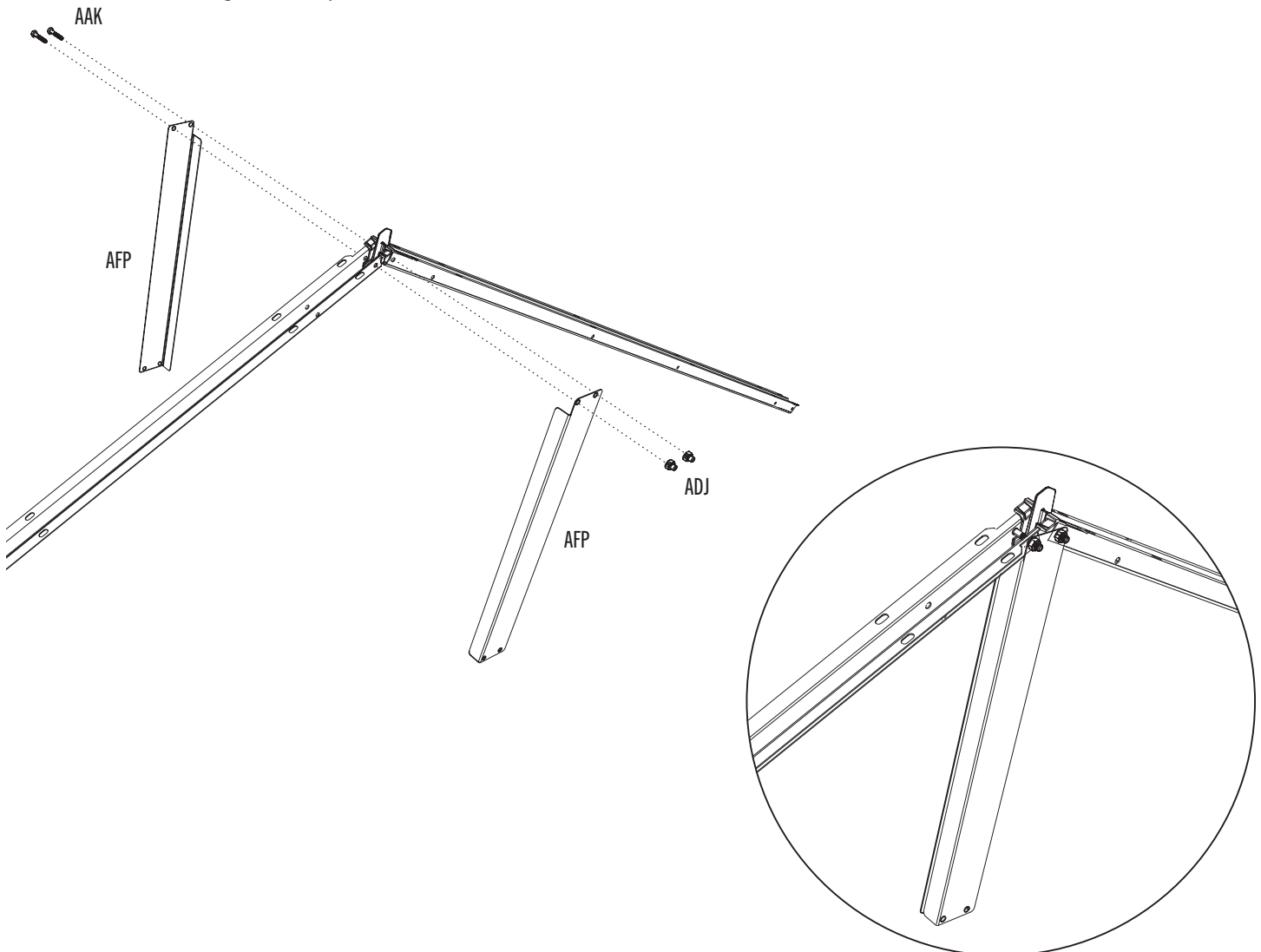

► SECTION 2 (CONTINUED) / SECTION 2 (SUITE) / SECCIÓN 2 (CONTINUACIÓN)

TOOLS AND HARDWARE REQUIRED / OUTILS ET QUINCAILLERIE REQUIS / INSTRUMENTAL Y HERRAJE REQUERIDOS



7/16 in/po (x2)
≈11 mm

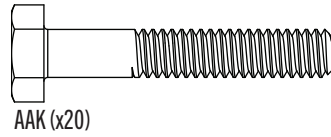

AAK (x20)



ADJ (x20)

2.3

- Secure a **horizontal truss brace (AFG)** to the channels and the vertical truss braces using four (4) **bolts (AAK)** and **cap nuts (ADJ)**. **Do not overtighten the nuts.**
- Attachez bien un **support horizontal (AFG)** aux canaux et aux supports verticaux à l'aide de quatre (4) **boulons (AAK)** et **écrous borgnes (ADJ)**. **Ne pas trop serrer.**
- Sujete un **soporte horizontal (AFG)** a los canalones y los soportes verticales usando cuatro (4) **pernos (AAK)** y **tuercas ciegas (ADJ)**. **No apriete demasiado las tuercas.**

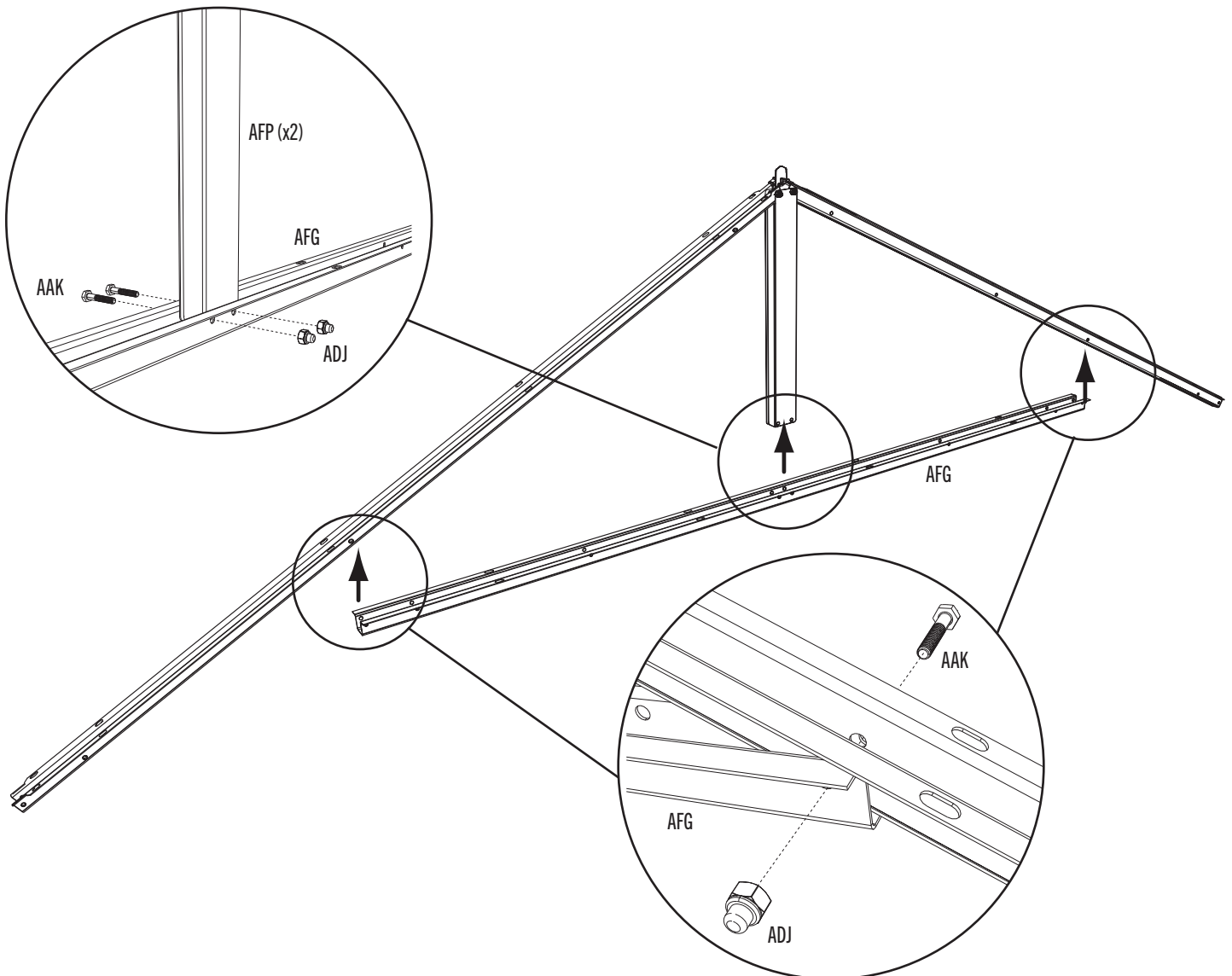

SECTION 2 (CONTINUED) / SECTION 2 (SUITE) / SECCIÓN 2 (CONTINUACIÓN)

TOOLS AND HARDWARE REQUIRED / OUTILS ET QUINCAILLERIE REQUIS / INSTRUMENTAL Y HERRAJE REQUERIDOS



7/16 in/po (x2)
≈11 mm

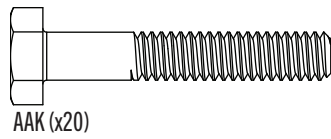

AAK (x20)



ADJ (x20)

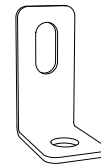

AHT (x10)

2.4

- Attach a **wall support channel (AFQ)** to each end of the truss assembly using the hardware provided. **Do not overtighten.**
- Attachez un **canal de support pour le mur (AFQ)** à chaque extrémité de l'ensemble de la ferme à l'aide de la quincaillerie incluse. **Ne pas trop serrer.**
- Sujete un **canal de soporte para el muro (AFQ)** a cada extremo del conjunto de la cercha usando el herraje incluido. **No apriete demasiado.**

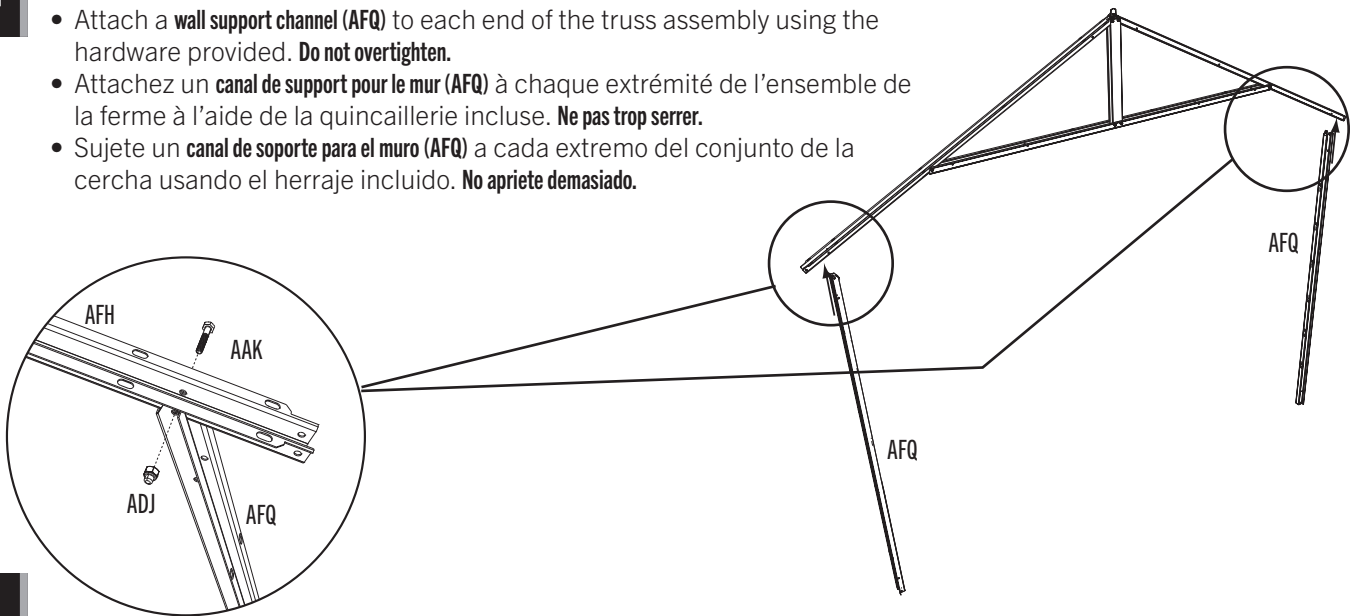

2.5

- Attach a **floor bracket (AHT)** to the bottom of each wall support channel. **Do not overtighten. Repeat this section four times.**
- Attachez un **support de la ferme (AHT)** à l'extrémité inférieure de chaque canal de support à mur. **Ne pas trop serrer. Répétez cette section quatre fois.**
- Sujete un **soporte para la cercha (AHT)** al extremo inferior de cada canal de soporte para el muro. **No apriete demasiado. Repita esta sección cuatro veces.**

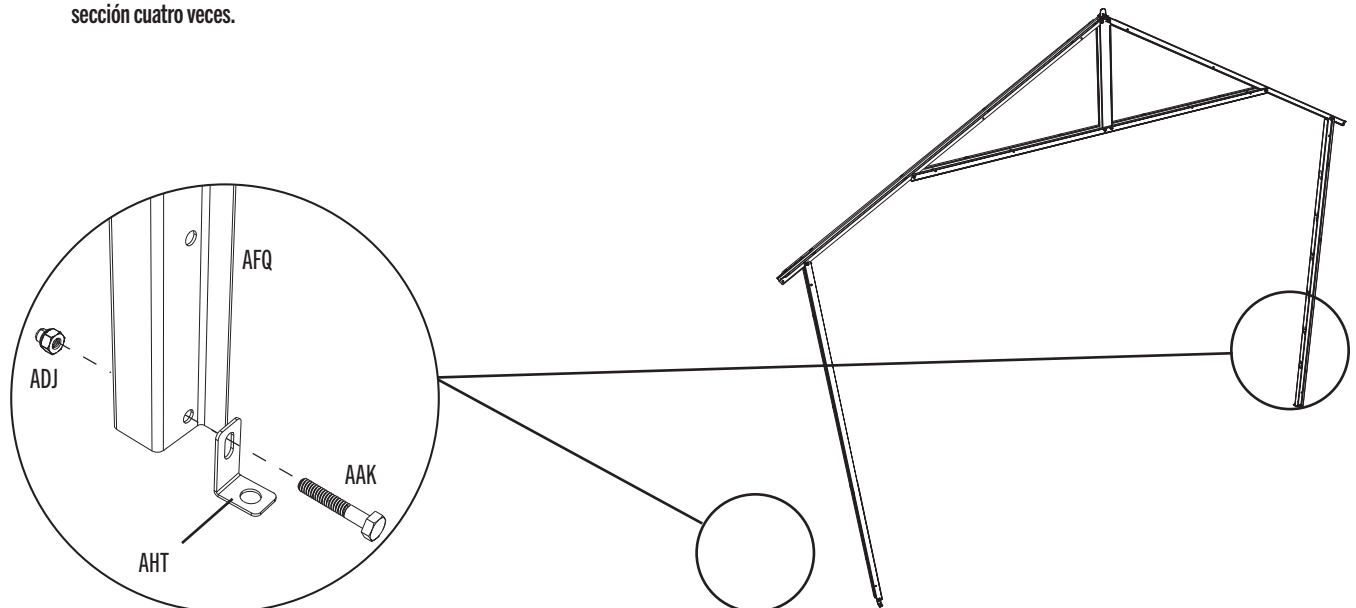

3

GABLE ASSEMBLY / ASSEMBLAGE DES PIGNONS / ENSAMBLAJE DE LAS FACHADAS



HARDWARE REQUIRED / QUINCAILLERIE REQUISE / HERRAJE REQUERIDO

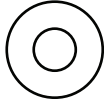

AEE (x10)

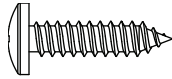

ADW (x10)

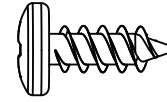

ADZ (x8)

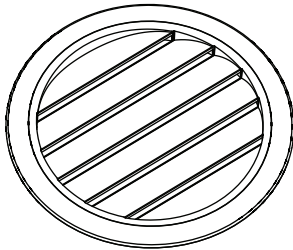

AGP (x2)

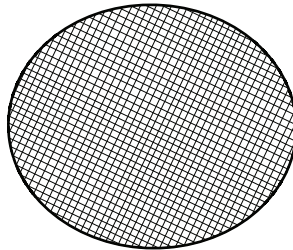

AIQ (x2)



PARTS REQUIRED / PIÈCES REQUISES / PIEZAS REQUERIDAS

Plastic parts / Pièces en plastique / Piezas de plástico

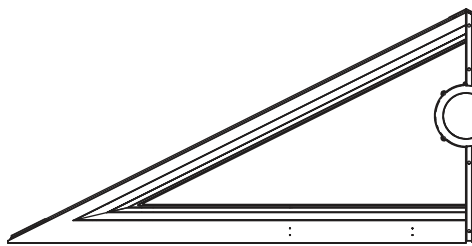

AGH (x2)

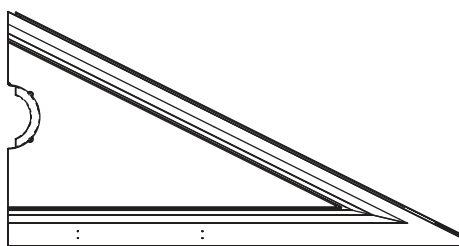

AGI (x2)



TOOLS REQUIRED / OUTILS REQUIS / INSTRUMENTAL REQUERIDO

(Not included—unless otherwise indicated*) / (Non inclus — sauf indication contraire*) / (No incluido, salvo indicación contratia*)



► SECTION 3 (CONTINUED) / SECTION 3 (SUITE) / SECCIÓN 3 (CONTINUACIÓN)

TOOLS AND HARDWARE REQUIRED / OUTILS ET QUINCAILLERIE REQUIS / INSTRUMENTAL Y HERRAJE REQUERIDOS

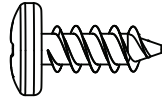

ADZ (x8)

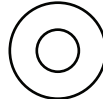

AEE (x10)

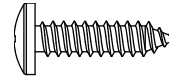

ADW (x10)

3.1

- Set the edge of **gable side A (AGH)** over the edge of **gable side B (AGI)**, and align the four holes.
- Mettre le bord du **pignon A (AGH)** sur le bord du **pignon B (AGI)**, et aligner les quatre trous.
- Colocar el borde de la **fachada A (AGH)** encima del borde de la **fachada B (AGI)**, y alinear los cuatro agujeros.

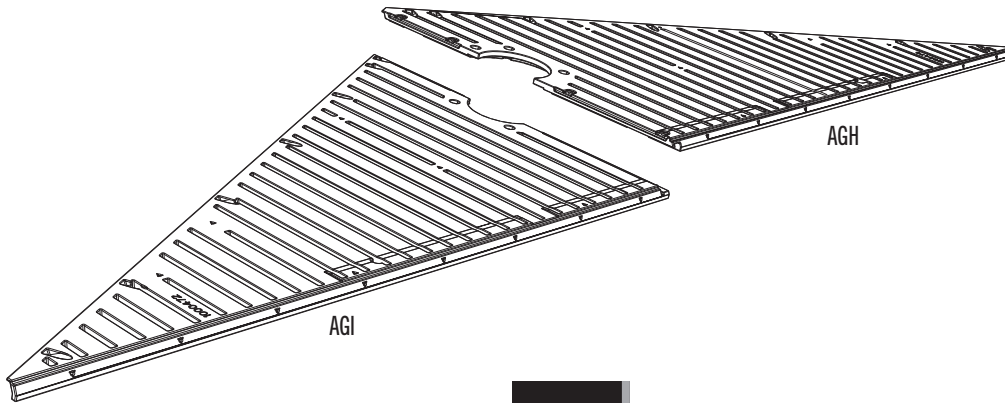

3.2

- Secure gable side A to gable side B using the hardware included.
- Attacher le pignon A au pignon B à l'aide de la quincaillerie incluse.
- Sujetar la fachada A a la fachada B usando el herraje incluido.

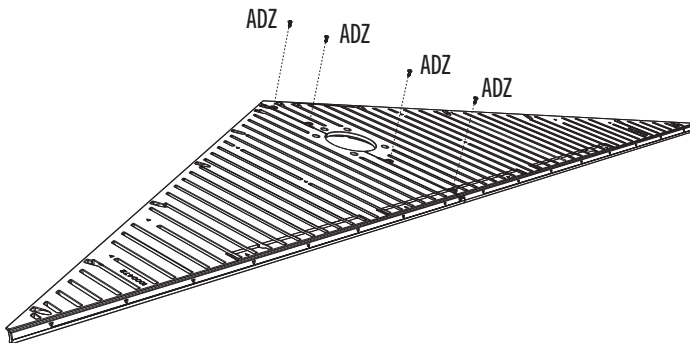

3.3



- Place a **screen (AIQ)** over a **vent (AGP)**. Set the gable assembly over the screen and vent so the holes in the gable align with those in the vent. Secure with the hardware included. **Repeat these steps for the second gable.**
- Mettre un **mosquitaire (AIQ)** sur un **évent (AGP)**. Mettre le pignon sur le mosquitaire et l'évent pour que les trous dans le pignon s'alignent avec ceux de l'évent. Attacher l'évent au pignon à l'aide des accessoires inclus. **Répéter ces étapes pour le deuxième pignon.**
- Colocar un **mosquitero (AIQ)** encima de una **ventila (AGP)**. Colocar la fachada encima del mosquitero y la ventila para que los agujeros en la fachada se alineen con ellos en la ventila. Sujetar la la ventila a la fachada usando el herraje incluido. **Repitir estos pasos para la segunda fachada.**

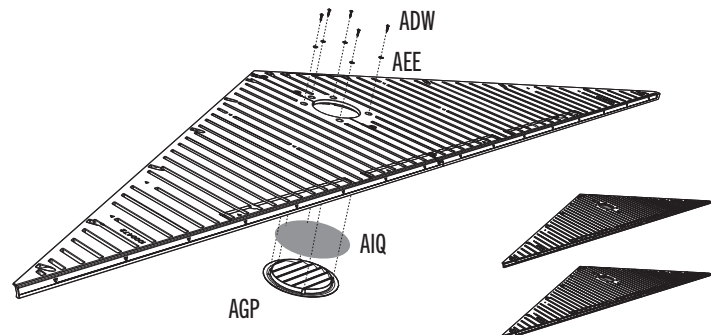

4

LEFT DOOR ASSEMBLY / ASSEMBLAGE DE LA PORTE GAUCHE / ENSAMBLAJE DE LA PUERTA IZQUIERDA



HARDWARE REQUIRED / QUINCAILLERIE REQUISE / HERRAJE REQUERIDO

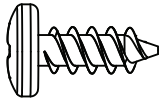

ADZ (x9)

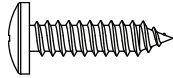

ADW (x3)

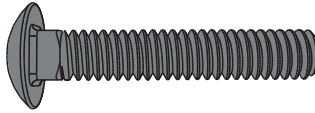

ACH (x2)



ADJ (x2)

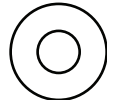

AEE (x3)



AHZ (x1)

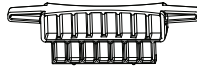

AHM (x2)

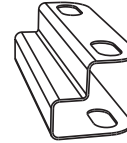

AIB (x1)

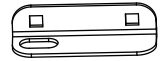

AIA (x1)



PARTS REQUIRED / PIÈCES REQUISES / PIEZAS REQUERIDAS

Metal parts / Pièces en métal / Piezas de metal



77 13/16 in/po (1,98 m)

AFC (x1)

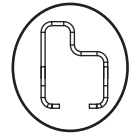

EGL



18 1/2 in/po (47 cm)

AFB (x3)

Plastic parts / Pièces en plastique / Piezas de plástico

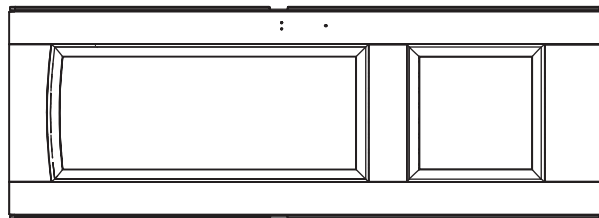

AGO (x1)



TOOLS REQUIRED / OUTILS REQUIS / INSTRUMENTAL REQUERIDO

(Not included—unless otherwise indicated*) / (Non inclus — sauf indication contraire*) / (No incluido, salvo indicación contraria*)

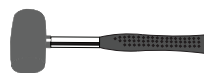

7/16 in/po (≈11 mm)

► SECTION 4 (CONTINUED) / SECTION 4 (SUITE) / SECCIÓN 4 (CONTINUACIÓN)

TOOLS AND HARDWARE REQUIRED / OUTILS ET QUINCAILLERIE REQUIS / INSTRUMENTAL Y HERRAJE REQUERIDOS

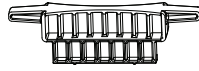

AHM (x2)

4.1

- Set the **deadbolts (AHM)** down into the recesses at the top and bottom of the door. Then, slide the **door end channel (AFC)** over the edge of the door and the bottom of the deadbolts as shown.
- Mettez les **loquets à pêne dormant (AHM)** dans les encoches aux parties supérieure et inférieure de la porte. Ensuite, faites glisser le **canal pour l'extrémité de la porte (AFC)** sur le bord de la porte et les parties inférieures des loquets à pêne dormant comme illustré.
- Ponga los **cerrojos (AHM)** en las muescas a las partes superior e inferior de la puerta. Entonces, deslice el **canal para el borde de la puerta (AFC)** sobre el borde de la puerta y las partes inferiores de los cerrojos como se muestra.

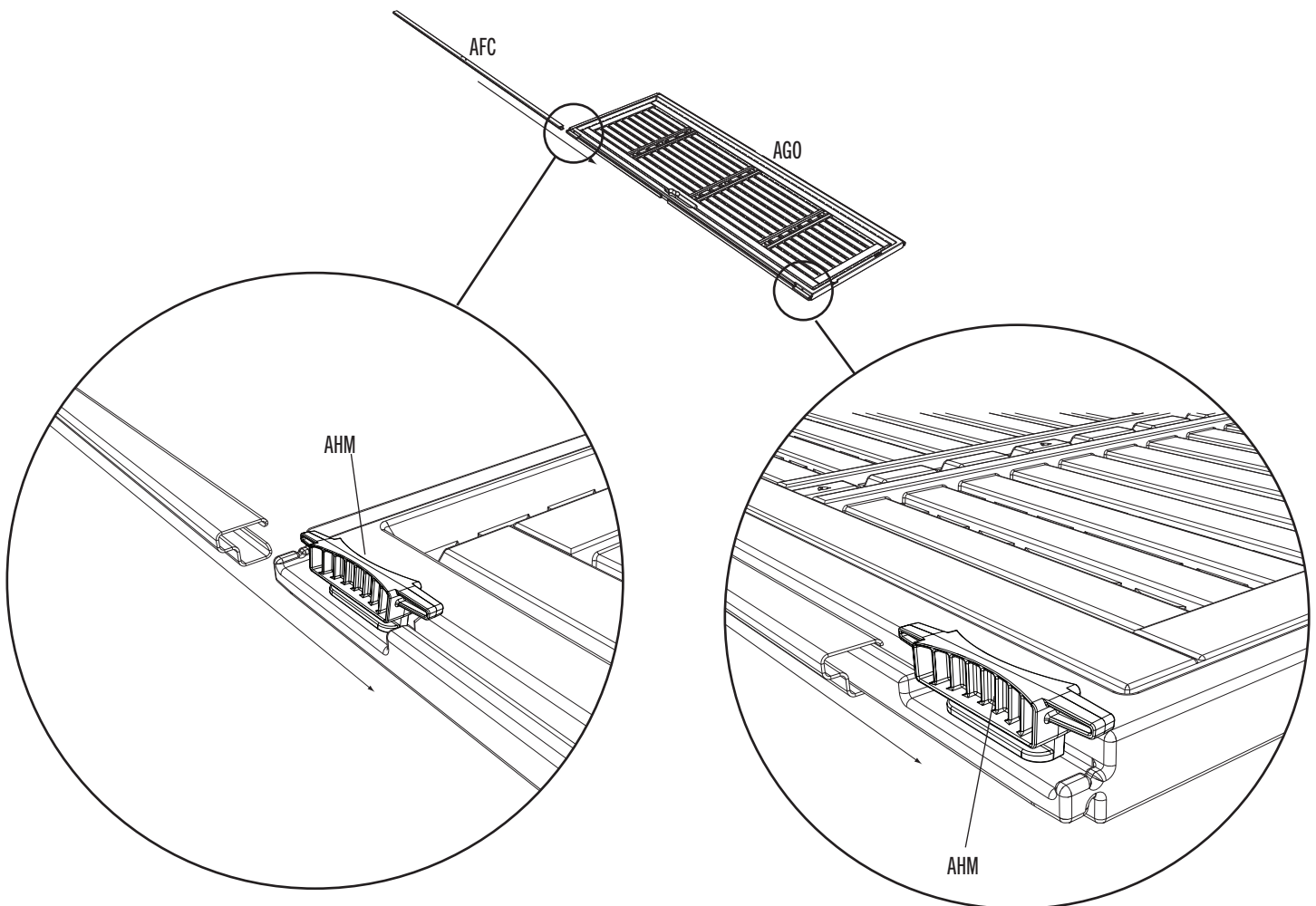

► SECTION 4 (CONTINUED) / SECTION 4 (SUITE) / SECCIÓN 4 (CONTINUACIÓN)

TOOLS AND HARDWARE REQUIRED / OUTILS ET QUINCAILLERIE REQUIS / INSTRUMENTAL Y HERRAJE REQUERIDOS

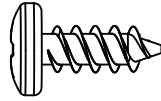

ADZ (x9)



- The deadbolts are used for locking the door. They may not move freely at first. You may need to tap them up and down a few times with a rubber mallet to work them in.
- On utilise les loquets pour fermer la porte. Au début, il se peut que les Loquets ne se déplacent librement. Vous devrez peut-être les taper légèrement à l'aide d'un maillet en caoutchouc pour les desserrer.
- Se usan los cerrojos para cerrar la puerta. Al principio, pueden que no se desplacen libremente. Puede que necesite darlos unos golpecitos con un mazo de goma para aflojarlos.

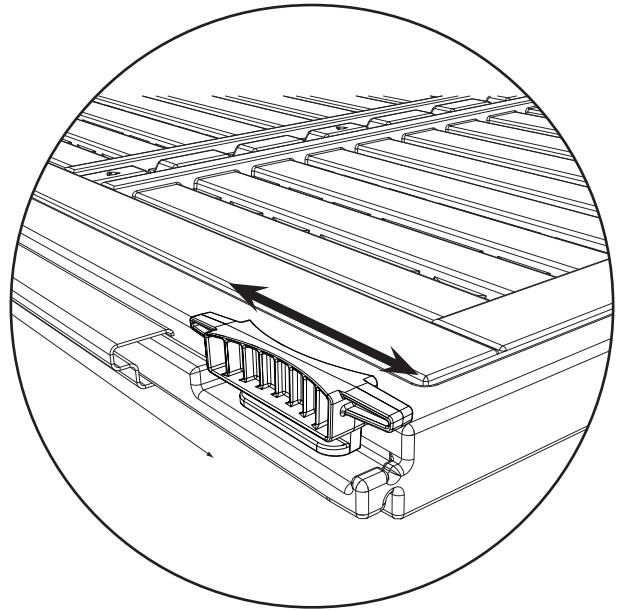

4.2

- Attach three (3) **door braces (AFB)** to the back of the left door.
- Attachez trois (3) **supports à la porte (AFB)** au côté arrière de la porte gauche.
- Sujete tres (3) **soportes para la puerta (AFB)** a la cara trasera de la puerta izquierda.

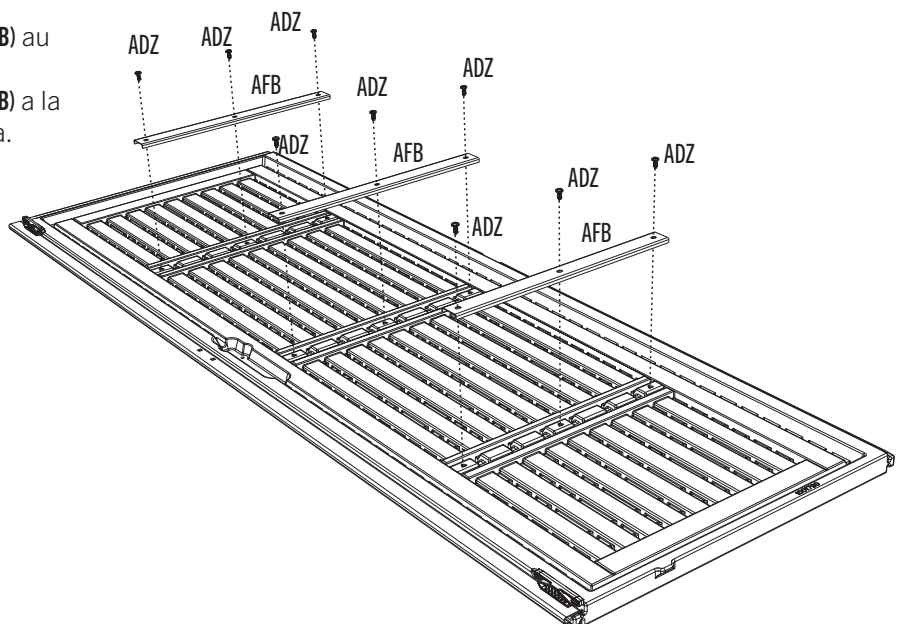

SECTION 4 (CONTINUED) / SECTION 4 (SUITE) / SECCIÓN 4 (CONTINUACIÓN)

TOOLS AND HARDWARE REQUIRED / OUTILS ET QUINCAILLERIE REQUIS / INSTRUMENTAL Y HERRAJE REQUERIDOS



7/16 in/po (x2)
(≈11 mm)

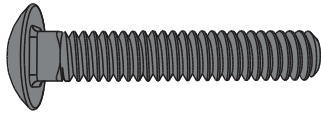

ACH (x2)

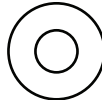

AEE (x3)



ADJ (x2)

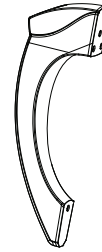

AHZ (x1)

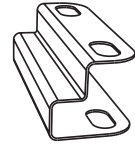

AIB (x1)

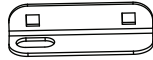

AIA (x1)

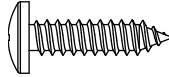

ADW (x3)

4.3

- Slide the **strike plate (AIB)** over the door end channel, and align the holes.
- Faites glisser la **gâche (AIB)** sur le canal au bord de la porte, et alignez les trous.
- Deslice la **placa de refuerzo (AIB)** sobre el canal para el borde de la puerta, y alinee los agujeros.

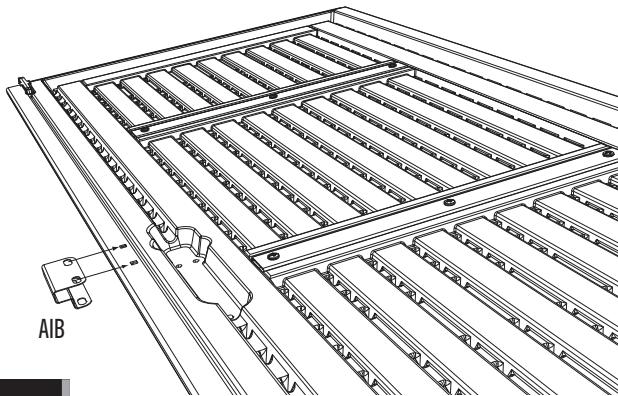

4.4

- Secure the **left door latch (AIA)** to the left door using the hardware provided. **Do not overtighten.**
- Bien attachez le **loquet gauche (AIA)** à la porte gauche à l'aide de la quincaillerie incluse. **Ne pas trop serrer.**
- Sujete el **pestillo de cierre izquierdo (AIA)** a la puerta izquierda usando el herraje incluido. **No apriete demasiado.**

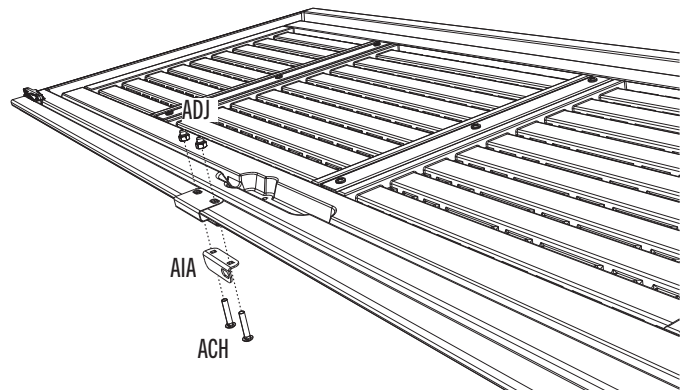

4.5

- Secure the **left door handle (AHZ)** to the left door using the hardware provided. **Do not overtighten.**
- Attachez bien la **poignée (AHZ)** à la porte gauche à l'aide de la quincaillerie incluse. **Ne pas trop serrer.**
- Sujete el **picaporte izquierdo (AHZ)** a la puerta izquierda usando el herraje incluido. **No apriete demasiado.**

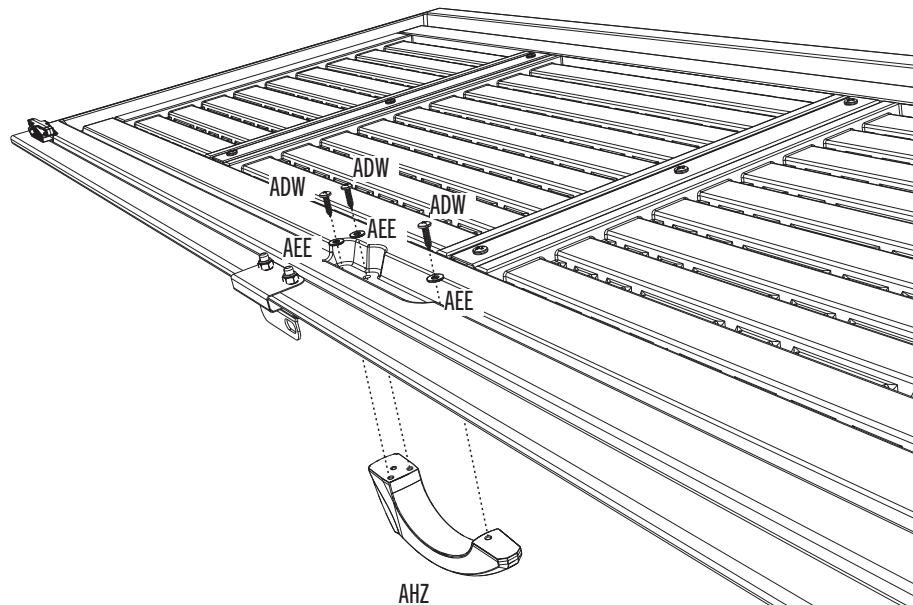

5

RIGHT DOOR ASSEMBLY / ASSEMBLAGE DE LA PORTE DROITE / ENSAMBLAJE DE LA PUERTA DERECHA



HARDWARE REQUIRED / QUINCAILLERIE REQUISE / HERRAJE REQUERIDO

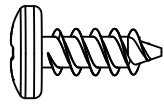

ADZ (x9)

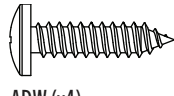

ADW (x4)

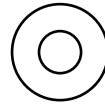

AEE (x3)

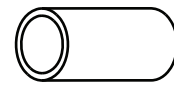

ADB (x2)

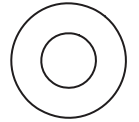

AEB (x2)

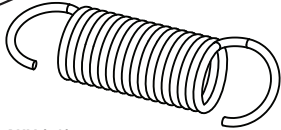

AHY (x1)

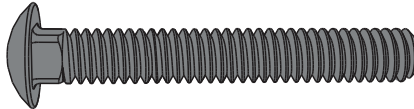

ACI (x2)

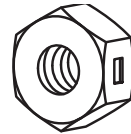

AAB (x2)

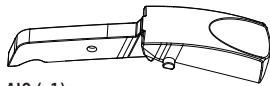

AIO (x1)

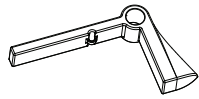

AHV (x1)



AIK (x1)

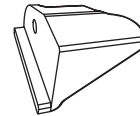

AHW (x1)

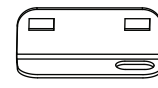

AIL (x1)

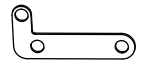

AHX (x1)



PARTS REQUIRED / PIÈCES REQUISES / PIEZAS REQUERIDAS

Metal parts / Pièces en métal / Piezas de metal



AFC (x1)

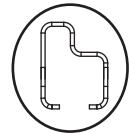

EGL

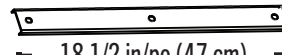

AFB (x3)

Plastic parts / Pièces en plastique / Piezas de plástico

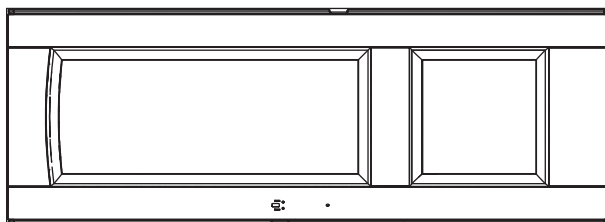

AGZ (x1)



TOOLS REQUIRED / OUTILS REQUIS / INSTRUMENTAL REQUERIDO

(Not included—unless otherwise indicated*) / (Non inclus — sauf indication contraire*) / (No incluido, salvo indicación contraria*)

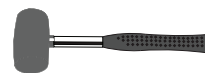
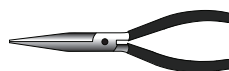

7/16 in/po (≈11 mm)

► SECTION 5 (CONTINUED) / SECTION 5 (SUITE) / SECCIÓN 5 (CONTINUACIÓN)

TOOLS AND HARDWARE REQUIRED / OUTILS ET QUINCAILLERIE REQUIS / INSTRUMENTAL Y HERRAJE REQUERIDOS



5.1

- Slide the **door end channel (AFC)** over the edge of the door as shown.
- Faites glisser le **canal pour le bord de la porte (AFC)** sur le bord de la porte comme illustré.
- Deslice el **canal para el borde de la puerta (AFC)** sobre el borde de la puerta como se muestra.

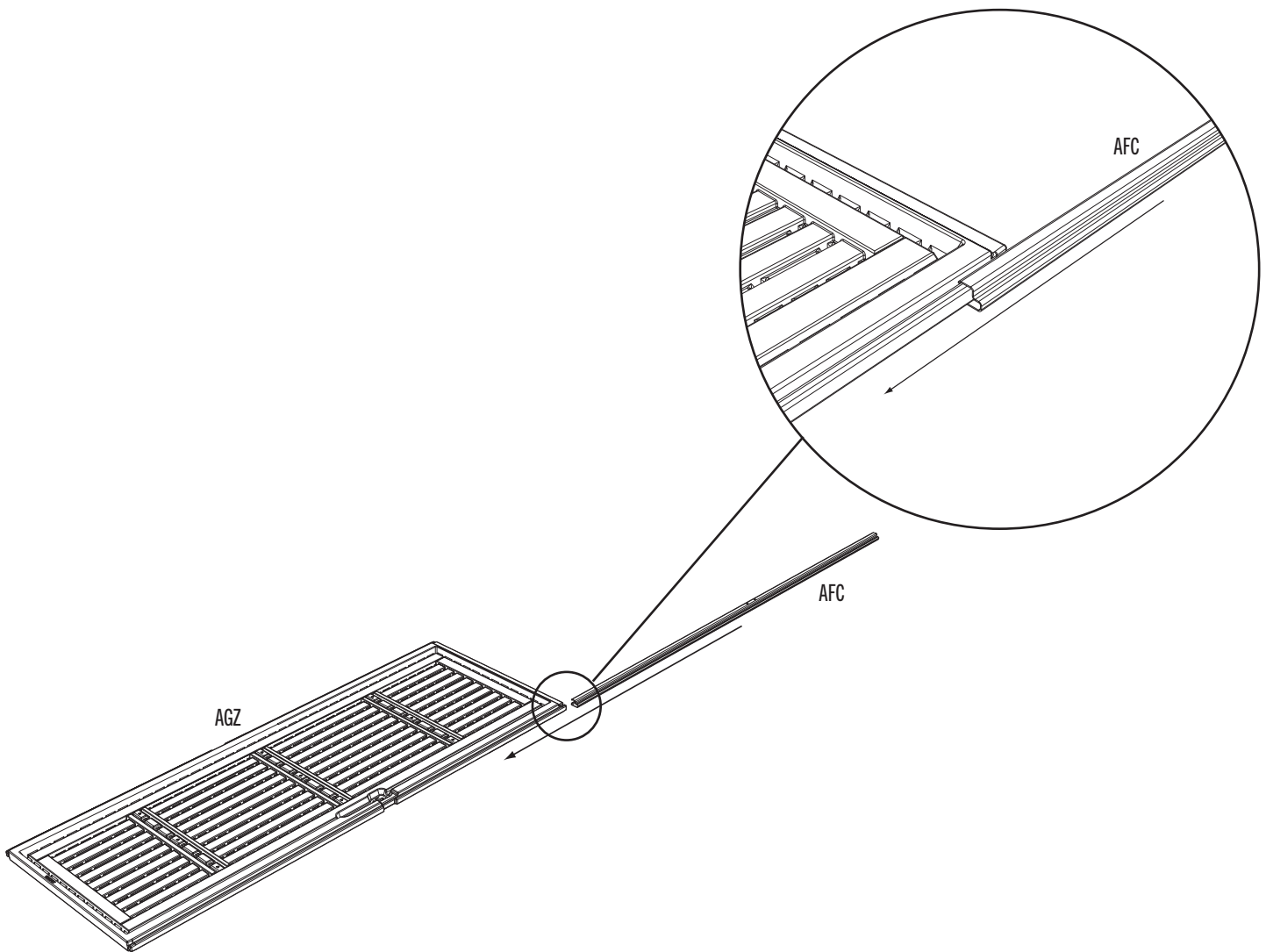

► SECTION 5 (CONTINUED) / SECTION 5 (SUITE) / SECCIÓN 5 (CONTINUACIÓN)

TOOLS AND HARDWARE REQUIRED / OUTILS ET QUINCAILLERIE REQUIS / INSTRUMENTAL Y HERRAJE REQUERIDOS

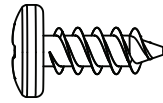

ADZ (9)

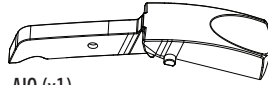

AIO (x1)

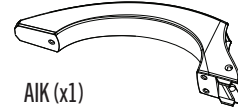

AIK (x1)

5.2

- Attach three (3) **door braces (AFB)** to the back of the right door.
- Attachez trois (3) **supports de la porte (AFB)** au côté arrière de la porte droite.
- Sujete tres (3) **soportes de la puerta (AFB)** a la cara trasera de la puerta derecha.

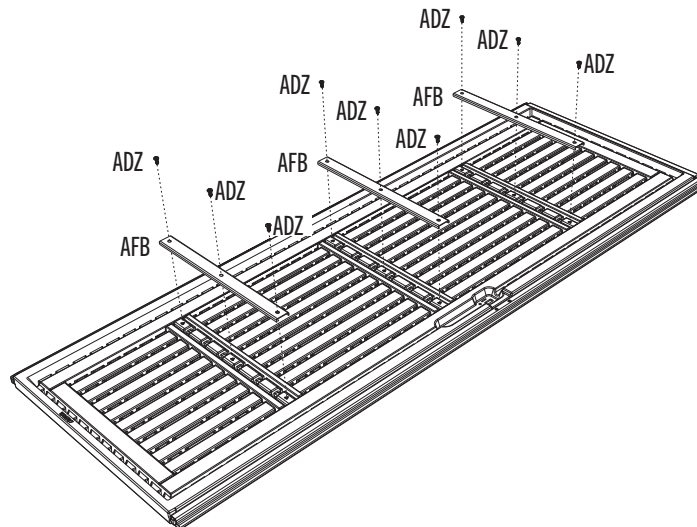

5.3

- Slide the **thumb lever (AIO)** down into the grooves in the **door handle (AIK)** until the nubs fit into the holes.
- Faites glisser le **levier poussoir (AIO)** dans les rainures de la **poignée (AIK)** jusqu'à ce que les petites bosses se fixent dans les trous.
- Deslice la **palanca de pulgar (AIO)** en las ranuras del **picaporte (AIK)** hasta que los nudos se encajen en los agujeros.

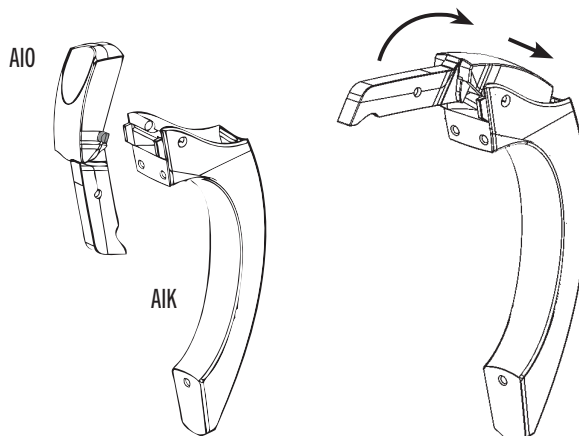

SECTION 5 (CONTINUED) / SECTION 5 (SUITE) / SECCIÓN 5 (CONTINUACIÓN)

TOOLS AND HARDWARE REQUIRED / OUTILS ET QUINCAILLERIE REQUIS / INSTRUMENTAL Y HERRAJE REQUERIDOS

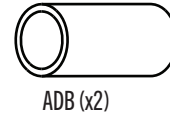
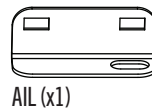
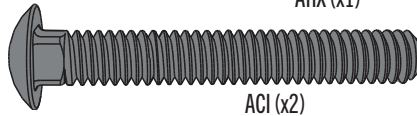
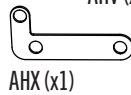
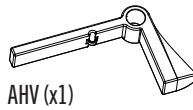
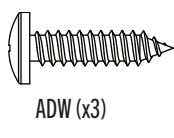
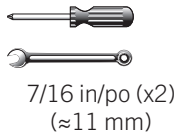

5.4

- Insert the thumb lever through the slot, and attach the handle using the hardware provided.
- Insérez le levier poussoir à travers la fente, et attachez la poignée à l'aide de la quincaillerie incluse.
- Inserte la palanca de pulgar a través de la ranura, y sujete el picaporte usando el herraje incluido.

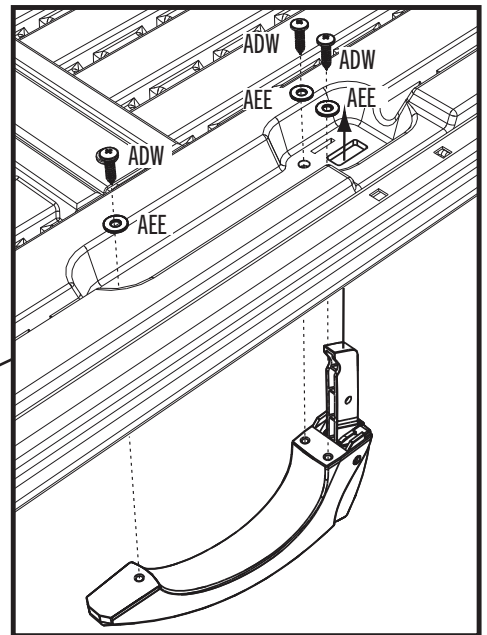
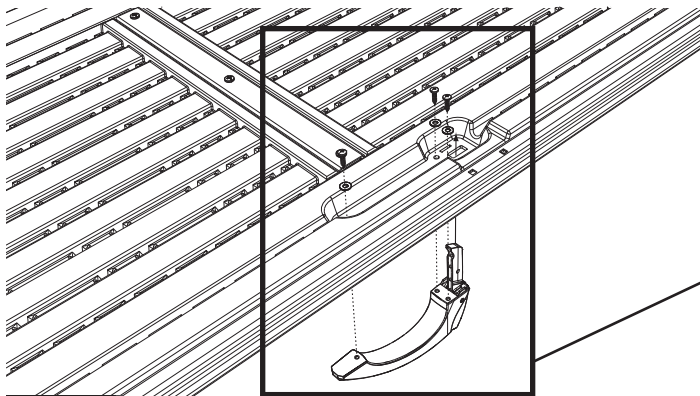

5.5

- Attach the locking hardware using the hardware provided. **The arm of the latch rests on top of the thumb lever.**
- Attachez les accessoires de verrouillage à l'aide de la quincaillerie incluse. **Le bras du loquet doit rester sur le levier poussoir.**
- Sujete los accesorios de cierre usando el herraje incluido. **El brazo del pestillo se queda sobre la palanca de pulgar.**

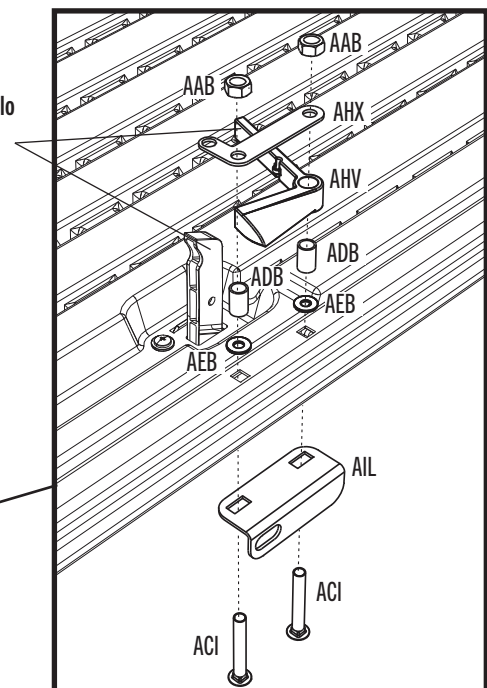
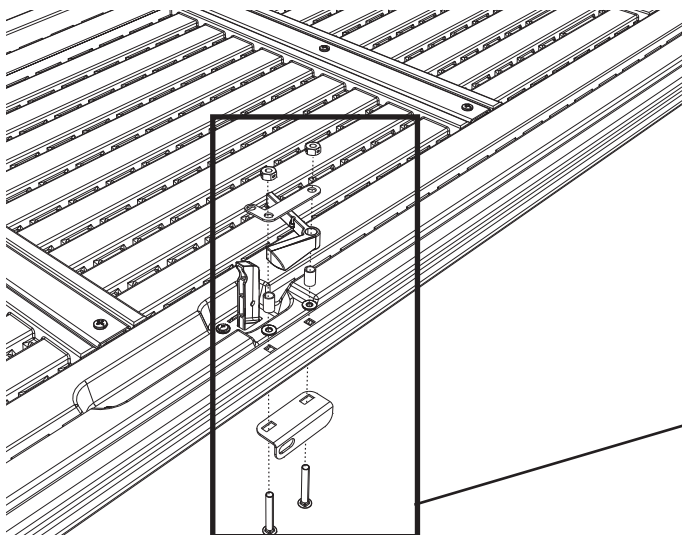

► SECTION 5 (CONTINUED) / SECTION 5 (SUITE) / SECCIÓN 5 (CONTINUACIÓN)

TOOLS AND HARDWARE REQUIRED / OUTILS ET QUINCAILLERIE REQUIS / INSTRUMENTAL Y HERRAJE REQUERIDOS

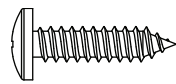
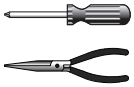

ADW (x1)

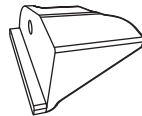

AHW (x1)

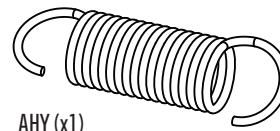

AHY (x1)

5.6

- Attach the **thumb lever support (AHW)** to the **thumb lever (AIO)** using a **screw (ADW)**. The edge of the support goes underneath the thumb lever.
- Attachez le **support du levier poussoir (AHW)** au **levier poussoir (AIO)** à l'aide d'une **vis (ADW)**. Le bord du support se fixe sous le levier poussoir.
- Sujete el **soporte de la palanca de pulgar (AHW)** a la **palanca de pulgar (AIO)** usando un **tornillo (ADW)**. El borde del soporte se fija debajo la palanca de pulgar.

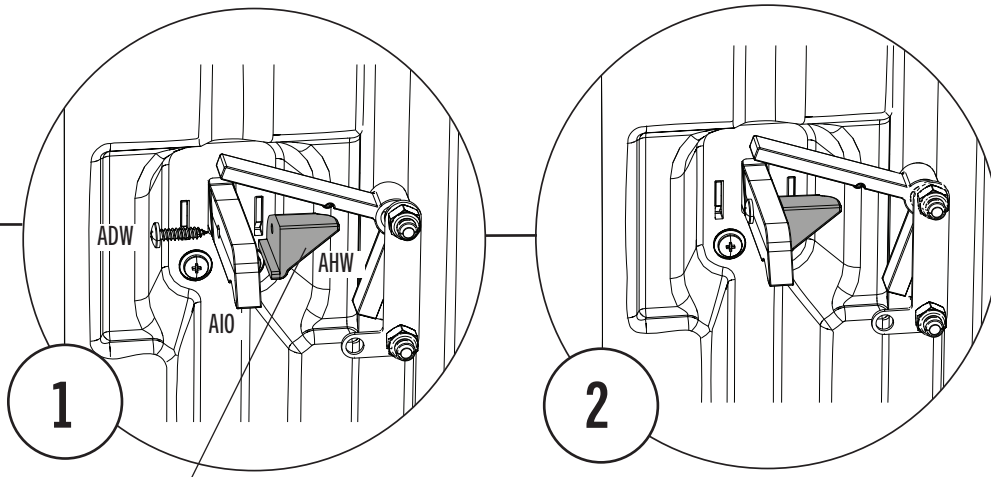
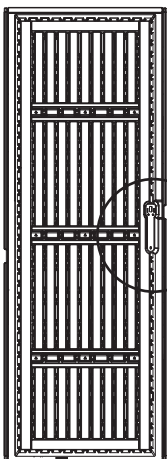

The edge of the support / Le bord du levier poussoir / El borde de la palanca de pulgar

5.7

- Attach the **spring (AHY)** to the **latch (AHV)** and **latch cover plate (AHX)** as shown.
- Attachez le **ressort (AHY)** au **loquet (AHV)** et la **plaque protectrice du loquet (AHX)** comme illustré.
- Sujete el **resorte (AHY)** al **pestillo (AHV)** y a la **placa cubrepestillo (AHX)** como se muestra.

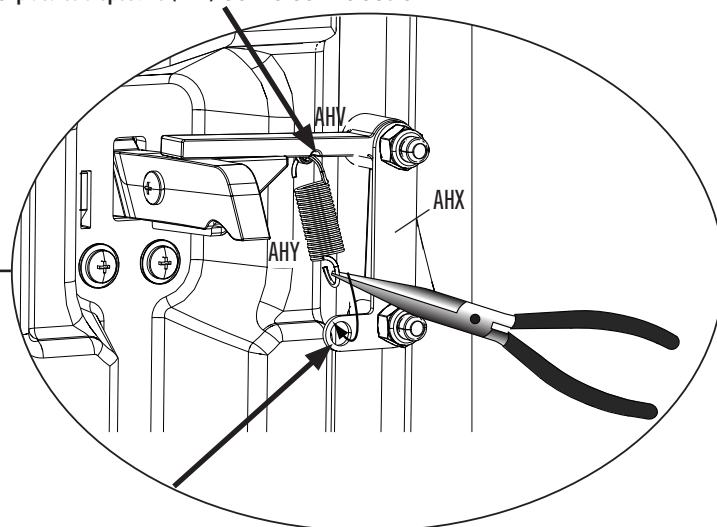
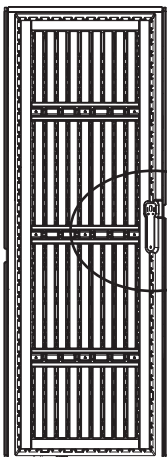

6

DOMED SKYLIGHT ASSEMBLY / ASSEMBLAGE DES LUCARNES EN FORME DE DÔME / ENSAMBLAJE DE LOS TRAGALUCES EN FORMA DE CÚPULA



HARDWARE REQUIRED / HERRAJE REQUERIDO / QUINCAILLERIE REQUISE



EFA (x24)



ADK (x24)

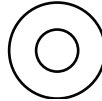

AEE (x48)



AHI (x2)



PARTS REQUIRED / PIÈCES REQUISES / PIEZAS REQUERIDAS

Plastic parts / Pièces en plastique / Piezas de plástico

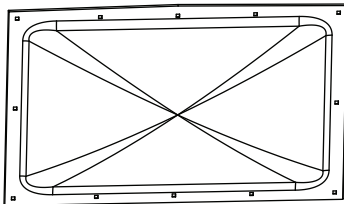

AGB (x2)

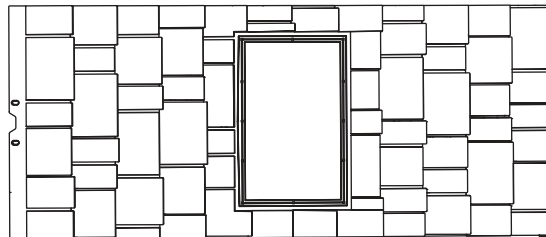

AHB (x2)



TOOLS REQUIRED / OUTILS REQUIS / INSTRUMENTAL REQUERIDO

(Not included—unless otherwise indicated*) / (Non inclus — sauf indication contraire*) / (No incluido, salvo indicación contratia*)



3/8 in/po (≈10 mm)



► SECTION 6 (CONTINUED) / SECTION 6 (SUITE) / SECCIÓN 6 (CONTINUACIÓN)

TOOLS AND HARDWARE REQUIRED / OUTILS ET QUINCAILLERIE REQUIS / INSTRUMENTAL Y HERRAJE REQUERIDOS



AHI (x2)

6.1

- Remove any excess plastic from the holes along the opening.
- Enlevez de l'excès de plastique des trous le long de l'ouverture.
- Retire cualquier plástico en exceso de los agujeros a lo largo de la abertura.

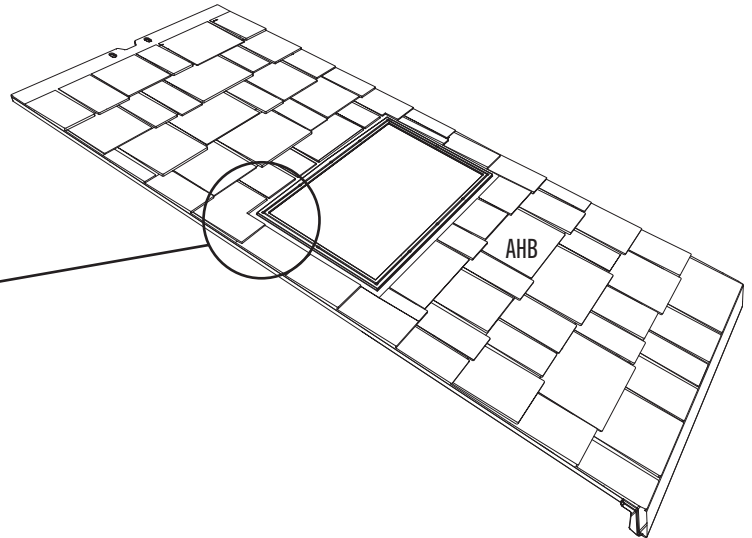
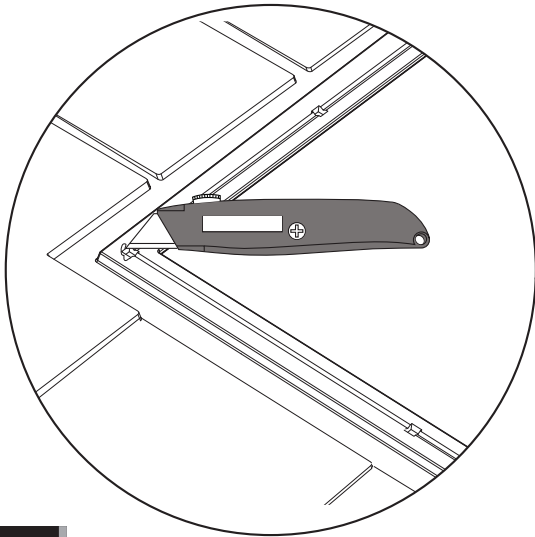

6.2

- Lay **butyl tape (AHI)** along the groove running along the top edge of the opening of the panel. Cut the butyl tape.
- Mettez le **ruban butylique (AHI)** le long de la rainure qui s'étend le long du bord supérieur de la couverture du panneau. Coupez le ruban butylique.
- Coloque la **cinta de butilo (AHI)** a lo largo de la ranura que corre a lo largo del borde superior de la abertura del panel. Corte la cinta de butilo.

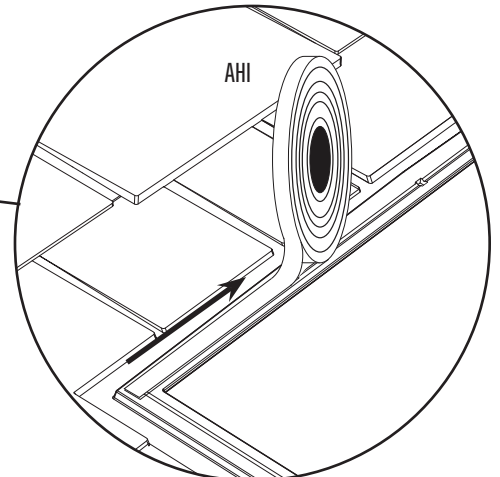
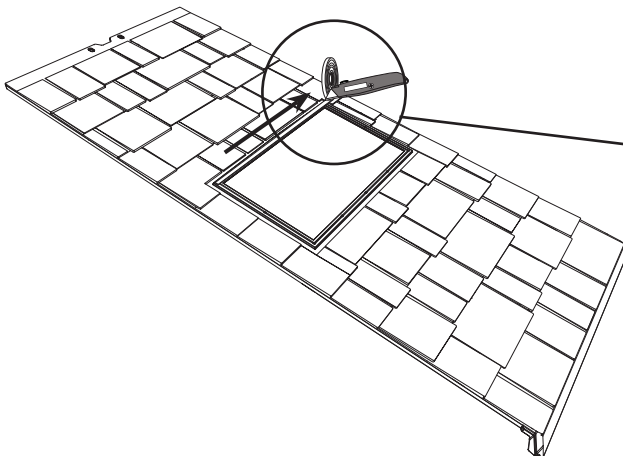

► SECTION 6 (CONTINUED) / SECTION 6 (SUITE) / SECCIÓN 6 (CONTINUACIÓN)

TOOLS AND HARDWARE REQUIRED / OUTILS ET QUINCAILLERIE REQUIS / INSTRUMENTAL Y HERRAJE REQUERIDOS



AHI (x2)

6.3

- **Do not remove any paper backing yet!** Lay butyl tape (AHI) along the groove running along the right edge of the opening of the panel. Cut the tape.
- **Ne pas retirer encore le papier protecteur!** Mettez le ruban butylique (AHI) le long de la rainure qui s'étend le long du bord droit de la couverture du panneau. Coupez le ruban.
- **¡No retire todavía el papel protector!** Coloque la cinta de butilo (AHI) a lo largo de la ranura que corre a lo largo del borde derecho de la abertura del panel. Corte la cinta.

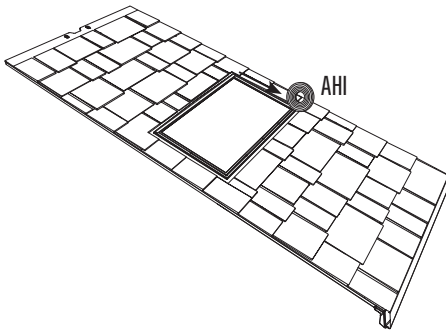

6.4

- **Do not remove any paper backing yet!** Lay butyl tape (AHI) along the groove running along the bottom edge of the opening of the panel. Cut the tape.
- **Ne pas retirer encore le papier protecteur!** Mettez le ruban butylique (AHI) le long de la rainure qui s'étend le long du bord inférieur de la couverture du panneau. Coupez le ruban.
- **¡No retire todavía el papel protector!** Coloque la cinta de butilo (AHI) a lo largo de la ranura que corre a lo largo del borde inferior de la abertura del Panel. Corte la cinta.

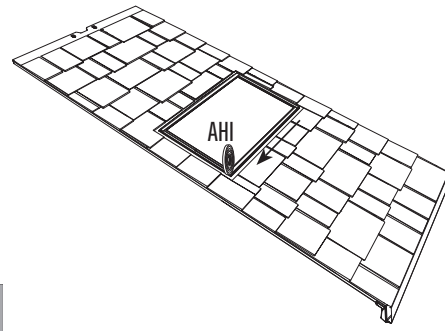

6.5

- **Do not remove any paper backing yet!** Lay butyl tape (AHI) along the groove running along the left edge of the opening of the panel. Cut the tape.
- **Ne pas retirer encore le papier protecteur!** Mettez le ruban butylique (AHI) le long de la rainure qui s'étend le long du bord gauche de la couverture du panneau. Coupez le ruban.
- **¡No retire todavía el papel protector!** Coloque la cinta de butilo (AHI) a lo largo de la ranura que corre a lo largo del borde izquierdo de la abertura del panel. Corte la cinta.

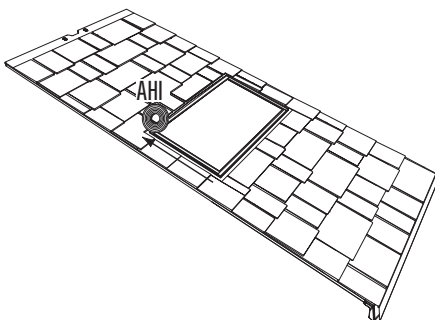

6.6

- **Smooth out the tape to remove any bubbles.** Remove the paper backing. Using a plain screwdriver, poke holes through the butyl tape and through the holes in the roof panel. The holes in the roof panel must remain square.
- **Lissez le ruban pour éliminer des bulles.** Enlevez la pellicule protectrice. Mettez un tournevis plat dans le ruban butylique et à travers les trous carrés dans le panneau de toit. Les trous dans le panneau de toit doivent rester carrés.
- **Alise la cinta para eliminar cualquier burbuja.** Retire el papel protector. Mete un destornillador de punta plana a través de la cinta butilo y los agujeros cuadrados en el panel de tejado. Los agujeros en el panel de tejado deben quedarse cuadrados.

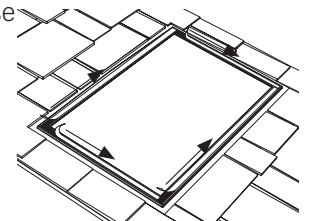

SECTION 6 (CONTINUED) / SECTION 6 (SUITE) / SECCIÓN 6 (CONTINUACIÓN)

TOOLS AND HARDWARE REQUIRED / OUTILS ET QUINCAILLERIE REQUIS / INSTRUMENTAL Y HERRAJE REQUERIDOS



3/8 in/po
(≈10 mm)

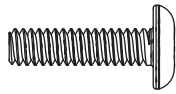

EFA (x24)



ADK (x24)

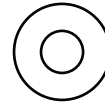

AEE (x48)

6.7

- Remove the protective film from both sides of the skylight (AGB).
- Soulevez la pellicule protectrice des deux côtés de la lucarne (AGB).
- Retire la capa protectora de los dos caras del tragaluz (AGB).

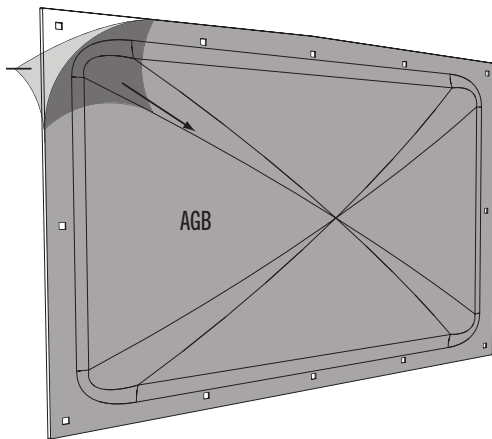

6.8

- Align the holes in the skylight with those in the panel, and lay the skylight on the panel. Press the skylight onto the butyl tape to remove any bubbles.
- Alignez les trous dans la lucarne avec ceux dans le panneau, et mettez la lucarne sur le panneau. Poussez la lucarne contre le ruban pour éliminer des bulles.
- Alinee los agujeros en el tragaluz con ellos en el panel, y coloque el tragaluz en el panel. Empuje el tragaluz contra la cinta para eliminar las burbujas.

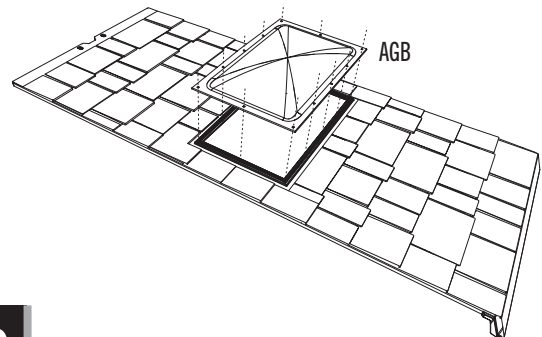

6.9

- Secure the skylight to the panel using the hardware provided.
- Attachez la lucarne au panneau à l'aide de la quincaillerie incluse.
- Sujete el tragaluz al panel usando el herraje incluido.

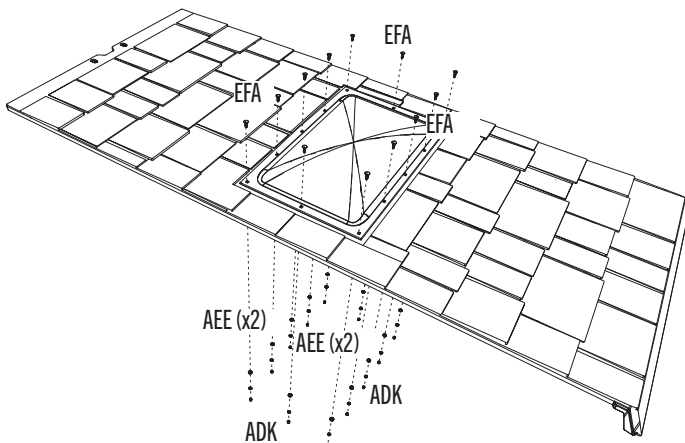

6.10

- Repeat this section for the second domed skylight.
- Répétez cette section pour la deuxième lucarne en forme de dôme.
- Repita esta sección para el segundo tragaluz en forma de cúpula.

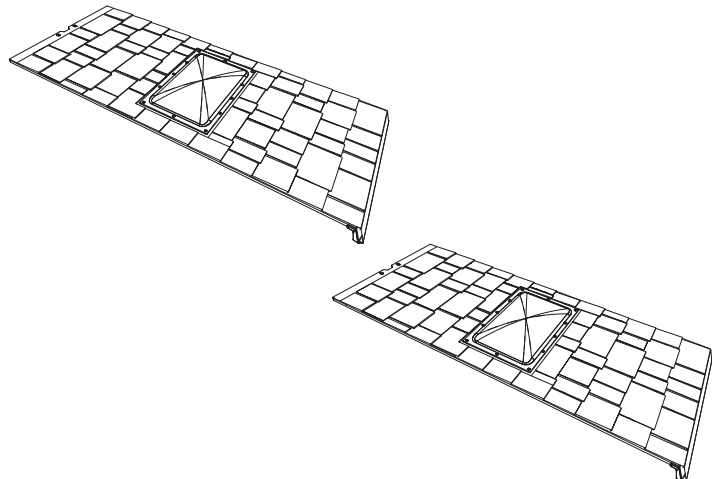

7

FLOOR ASSEMBLY / ASSEMBLAGE DU PLANCHER / ENSAMBLAJE DEL PISO



HARDWARE REQUIRED / HERRAJE REQUERIDO / QUINCAILLERIE REQUISE

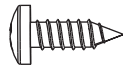

BQC (x50)



ADC (x1)



- These screws do not anchor the floor; they only hold the panels together.
- Ces vis n'ancrent pas le plancher ; ils ne servent que pour attacher les panneaux les uns aux autres.
- Estos tornillos no anclan el piso; sirven sólo para sujetar los paneles los unos a los otros.



PARTS REQUIRED / PIÈCES REQUISES / PIEZAS REQUERIDAS

Plastic parts / Pièces en plastique / Piezas de plástico

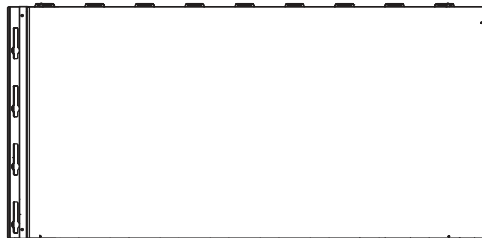

AGJ (x8)



AGS (x2)

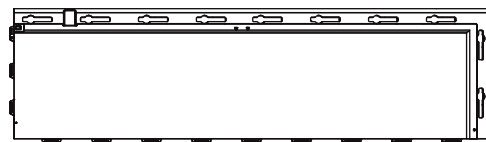

AGT (x2)



TOOLS REQUIRED / OUTILS REQUIS / INSTRUMENTAL REQUERIDO

(Not included—unless otherwise indicated*) / (Non inclus — sauf indication contraire*) / (No incluido, salvo indicación contraria*)



(x1)

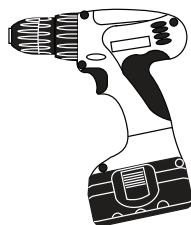

(x1)



ADC (x1)

► SECTION 7 (CONTINUED) / SECTION 7 (SUITE) / SECCIÓN 7 (CONTINUACIÓN)

TOOLS AND HARDWARE REQUIRED / OUTILS ET QUINCAILLERIE REQUIS / INSTRUMENTAL Y HERRAJE REQUERIDOS



7.1

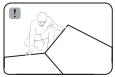

- Hold an **outer floor panel (AGS)** at an angle and slide the tabs along the edge underneath the other **outer floor panel (AGT)**. The tabs interlock. Lay panel down flat.
- Posez un **panneau de plancher extérieur (AGS)** à un angle et glissez les languettes le long du bord au-dessus de l'autre **panneau de plancher extérieur (AGT)**. Les languettes s'enclenchent les uns les autres. Étendez-le par terre.
- Coloque un **panel de piso exterior (AGS)** a un ángulo y deslice las lengüetas a lo largo del borde debajo el otro **panel de piso exterior (AGT)**. Las lengüetas se entrelazan las unas con las otras. Aplane el panel.

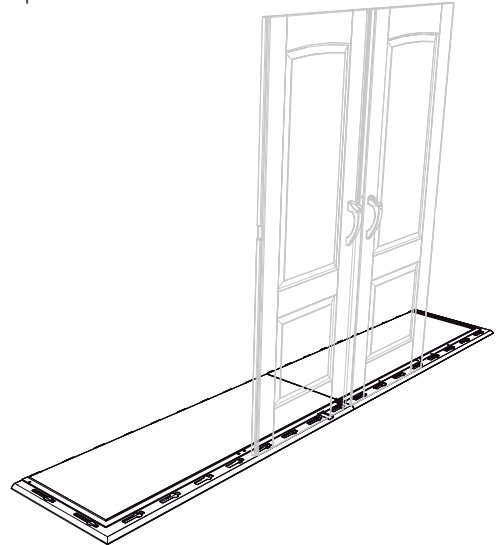
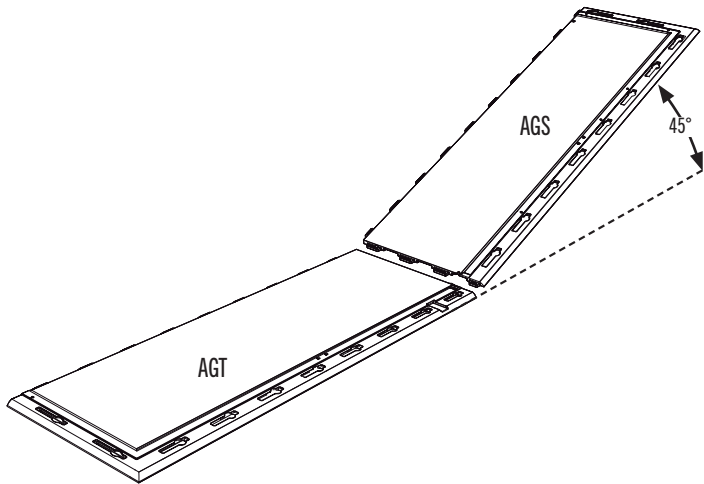

7.2

- Join two **inner floor panels (AGJ)**. Then, slide the tabs along the edge underneath the first two outer floor panels. The tabs interlock. Lay the panels down flat.
- Attachez deux **panneaux de plancher intérieurs (AGJ)**. Ensuite, glissez les languettes le long du bord au-dessus des autres panneaux de plancher extérieurs. Les languettes s'enclenchent les uns les autres. Étendez-les par terre.
- Junte dos **paneles de piso interiores (AGJ)**. Entonces, deslice las lengüetas a lo largo del borde debajo los otros paneles de piso exteriores. Las lengüetas se entrelazan las unas con las otras. Aplane los paneles.

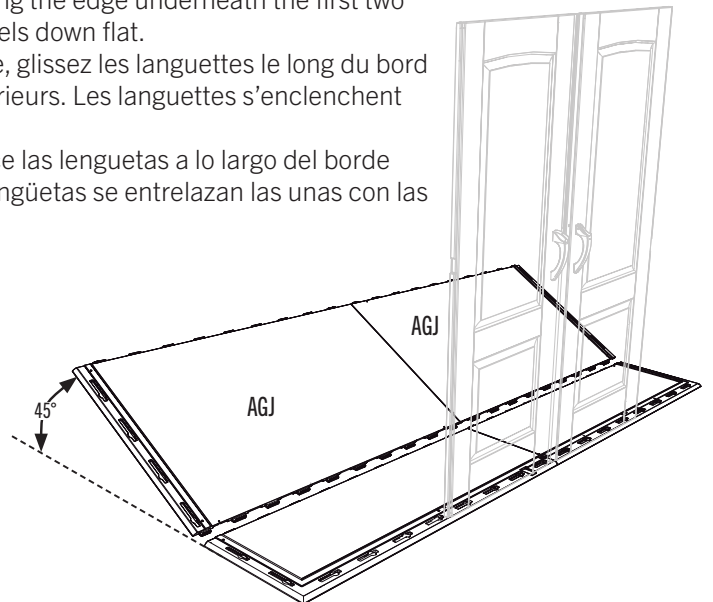
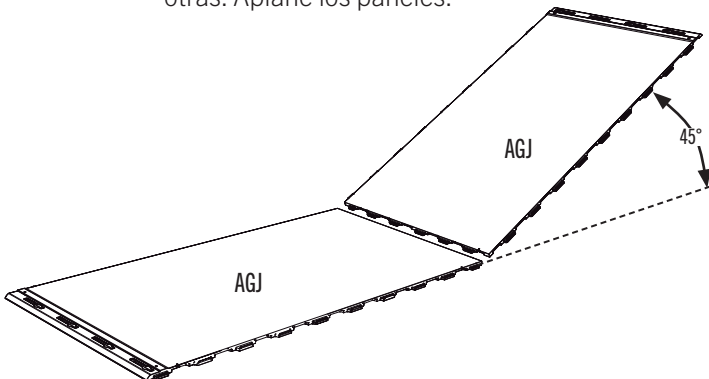

► SECTION 7 (CONTINUED) / SECTION 7 (SUITE) / SECCIÓN 7 (CONTINUACIÓN)

TOOLS AND HARDWARE REQUIRED / OUTILS ET QUINCAILLERIE REQUIS / INSTRUMENTAL Y HERRAJE REQUERIDOS



7.3

- Continue joining two **inner floor panels (AGJ)** and connecting them to the previous panels. Lay the panels down flat.
- Continuez à assembler deux **panneaux de plancher intérieurs (AGJ)** et à attacher les panneaux aux panneaux précédents. Étendez-les par terre.
- Continúe a juntar dos **paneles de piso interiores (AGJ)** y a conectarlo a los paneles anteriores. Aplane los paneles.

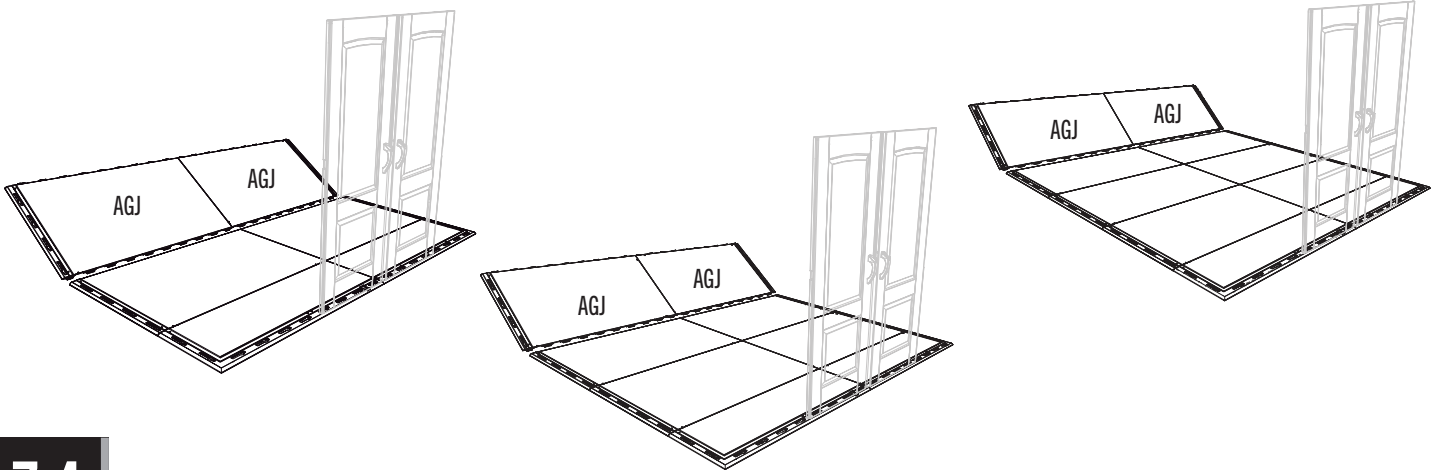

7.4

- Repeat the first step to join two more **outer floor panels (AGS & AGT)**. Then, slide the tabs along the edge underneath the last two inner floor panels. Lay the panels down flat.
- Répétez la première étape pour assembler deux plus **panneaux de plancher extérieurs (AGS et AGT)**. Ensuite, glissez les languettes le long du bord au-dessus des autres panneaux de plancher extérieurs. Étendez-les par terre.
- Repita el primer paso para unir dos más **paneles de piso exteriores (AGS y AGT)**. Entonces, deslice las languetas a lo largo del borde debajo los otros paneles de piso exteriores. Aplane los paneles.

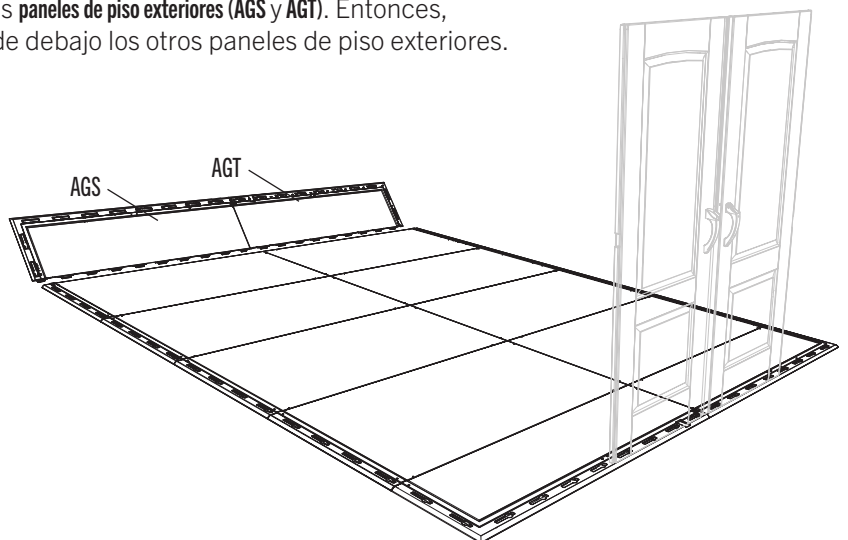

SECTION 7 (CONTINUED) / SECTION 7 (SUITE) / SECCIÓN 7 (CONTINUACIÓN)

TOOLS AND HARDWARE REQUIRED / OUTILS ET QUINCAILLERIE REQUIS / INSTRUMENTAL Y HERRAJE REQUERIDOS



ADC (x1)

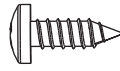

BQC (x32)



- *These screws do not anchor the floor; they only hold the panels together.*
- *Ces vis n'ancrent pas le plancher ; ils ne servent que pour attacher les panneaux les uns aux autres.*
- *Estos tornillos no anclan el piso; sirven sólo para sujetar los paneles los unos a los otros.*

7.5

- Use a screwdriver or drill to connect the panels together using the **screws (BQC)** provided: (1) four screws in the divots at each seam intersection, (2) one screw in the divot near each end of the center seam, and (3) one screw in the divot near each seam along the sides of the floor. **Do not overtighten.**
- Employer un tournevis or perceuse électrique pour fixer les panneaux les uns les autres en utilisant les **vis (BQC)** incluses : (1) quatre vis dans les marques aux intersections de chaque jointure, (2) une vis près chaque extrémité de la jointure centrale, et (3) une vis dans la marque près chaque jointure le long des bords latéraux du plancher. **Ne pas trop serrer.**
- Usar un destornillador o taladro eléctrico para fijar los paneles usando los **tornillos (BQC)** incluidos: (1) cuatro tornillos en las marcas a los cruces de cada línea, (2) un tornillo en la marca cerca cada extremo de la línea central, y (3) un tornillo en la marca cerca cada línea a lo largo de los bordes laterales del piso. **No apretar demasiado.**

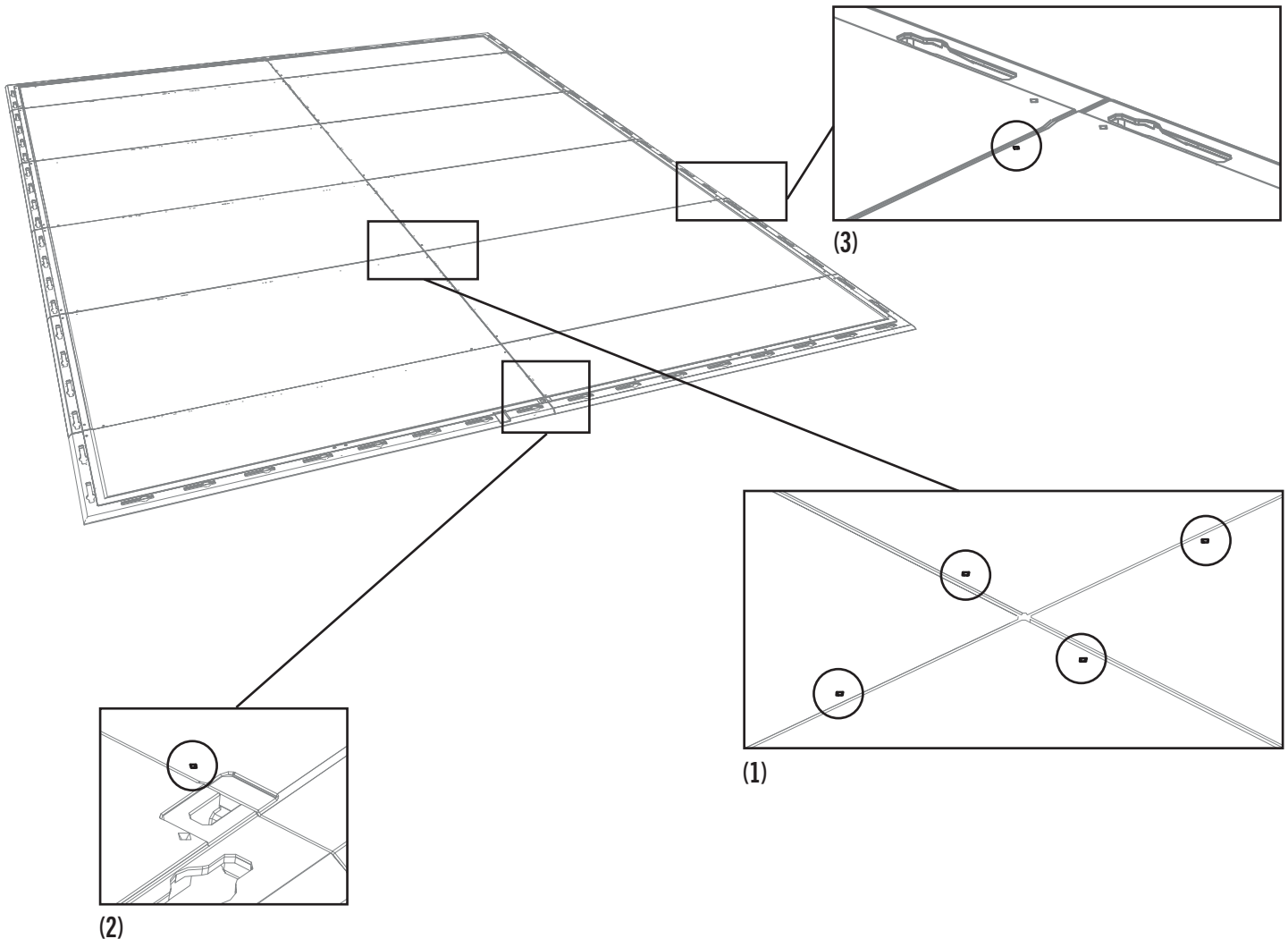

8

WALL ASSEMBLY / ASSEMBLAGE DES MURS / ENSAMBLAJE DE LOS MUROS



HARDWARE REQUIRED / QUINCAILLERIE REQUISE / HERRAJE REQUERIDO

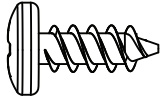

ADZ (x116)



ADC (x1)



PARTS REQUIRED / PIÈCES REQUISES / PIEZAS REQUERIDAS

Metal parts / Pièces en métal / Piezas de metal



AFR (x4)



Plastic parts / Pièces en plastique / Piezas de plástico

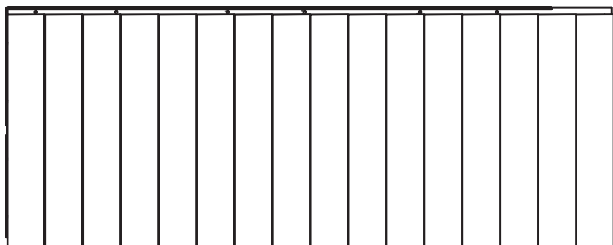

AHD (x14)

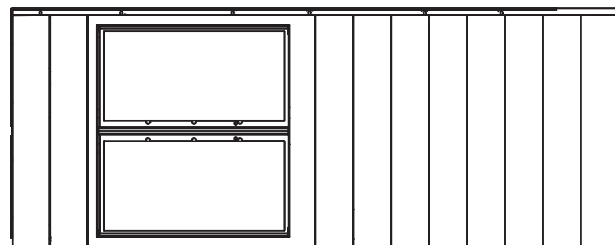

AHH (x2)



TOOLS REQUIRED / OUTILS REQUIS / INSTRUMENTAL REQUERIDO

(Not included—unless otherwise indicated*) / (Non inclus — sauf indication contraire*) / (No incluido, salvo indicación contratia*)



► SECTION 8 (CONTINUED) / SECTION 8 (SUITE) / SECCIÓN 8 (CONTINUACIÓN)

TOOLS AND HARDWARE REQUIRED / OUTILS ET QUINCAILLERIE REQUIS / INSTRUMENTAL Y HERRAJE REQUERIDOS



8.1

- Insert the tabs at the bottom of the **wall panel (AHD)** into the four slots along the front, right corner of the floor.
- Insérez les languettes au bord inférieur du **panneau mural (AHD)** dans les quatre rainures le long du coin avant droit du plancher.
- Introduzca las lengüetas al borde inferior del **panel mural (AHD)** en las cuatro ranuras a lo largo de la esquina delantera derecha del piso.

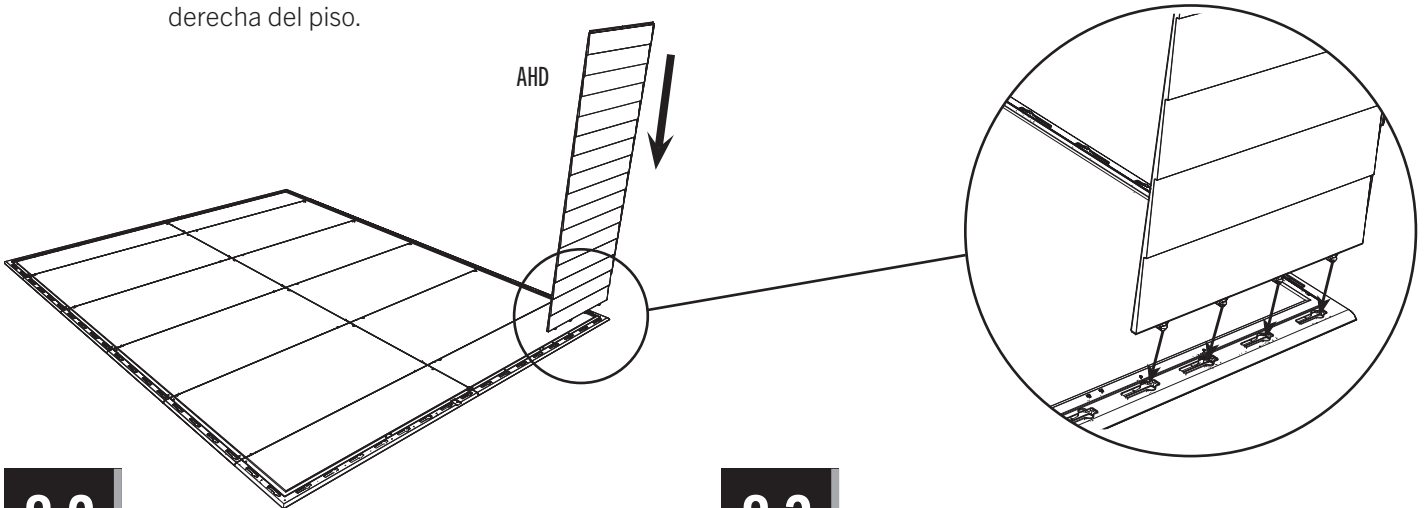

8.2

- Slide the wall panel to the left.
- Faites glisser le panneau mural à gauche.
- Deslice el panel mural a la izquierda.

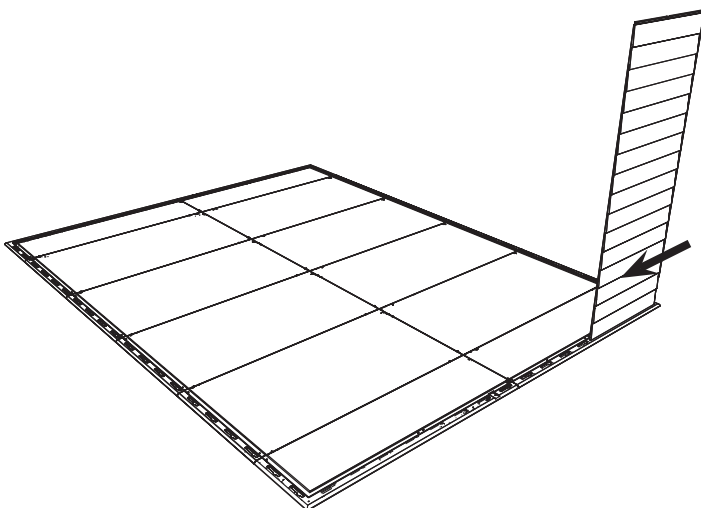

8.3



- Repeat the previous steps for the first wall panel along the right side of the floor.
- Répétez les étapes précédentes pour le premier panneau mural le long du bord droit du plancher.
- Repita los pasos anteriores para el primer panel mural a lo largo del borde derecho del piso.

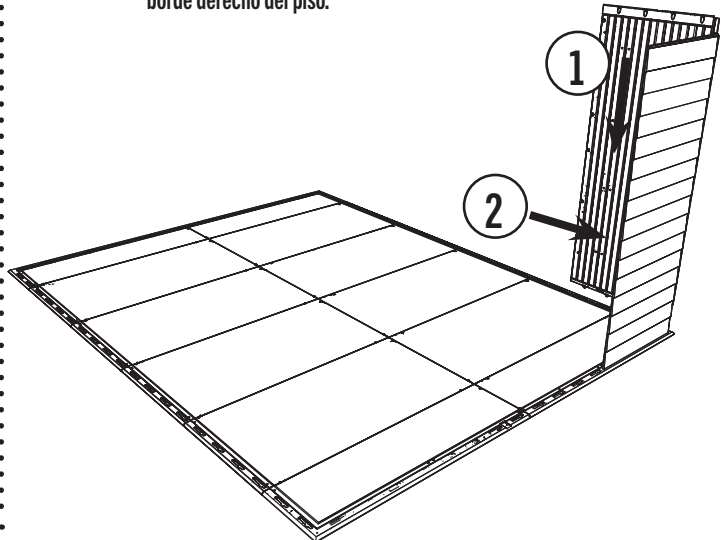

► SECTION 8 (CONTINUED) / SECTION 8 (SUITE) / SECCIÓN 8 (CONTINUACIÓN)

TOOLS AND HARDWARE REQUIRED / OUTILS ET QUINCAILLERIE REQUIS / INSTRUMENTAL Y HERRAJE REQUERIDOS

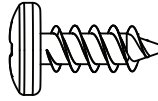

ADZ (x36)

8.4

- Align the holes in a **corner channel (AFR)** with the holes where the two panels connect. Attach the corner channel to the panels using the required hardware. **This step is done for each corner.**
- Aligned les trous dans le **canal angulaire (AFR)** avec les trous le long des bords des deux panneaux qui forment l'encoignure. Attachez le canal angulaire aux panneaux à l'aide de la quincaillerie requise. **Il faut faire cette étape pour chaque coin.**
- Alinee los agujeros en un **canal angular (AFR)** con los agujeros a lo largo de los dos paneles que forman l'angle. Sujete el canal angular a los paneles usando el herraje requerido. **Se hace este paso para cada esquina.**

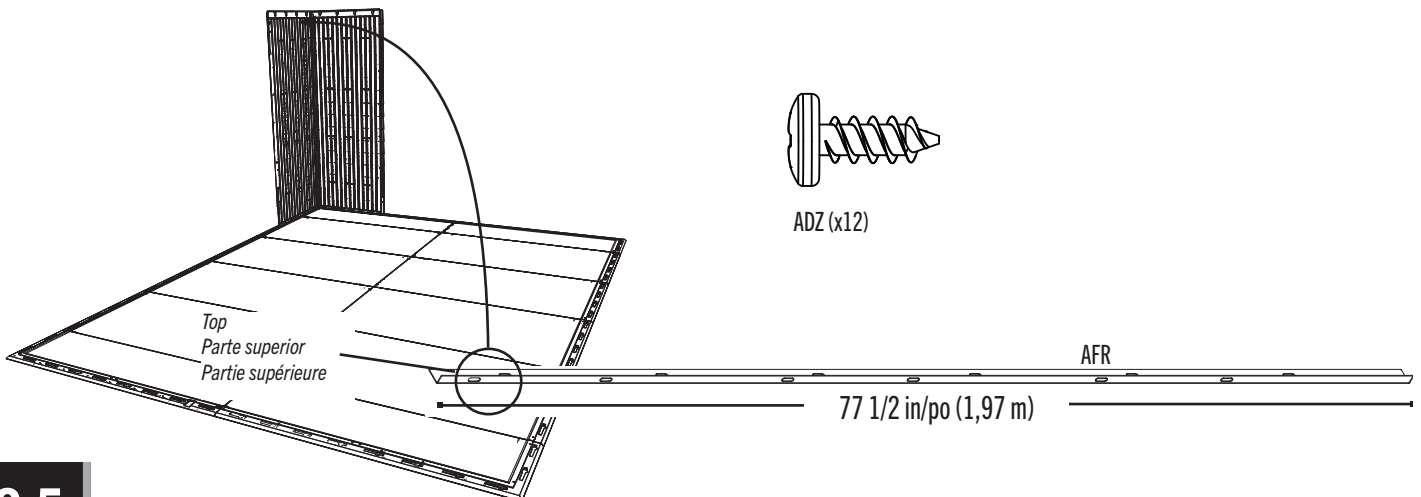

8.5

- One by one, insert the **wall panels (AHD & AHH)** into the slots along the right side of the floor, and then slide them toward the front. **The window wall panel may be placed in any non-corner position along the sides of the shed.** Secure the panels to one another using six (6) screws (ADZ) at each union.
- Un par un, insérez les **panneaux muraux (AHD et AHH)** dans les fentes le long du bord droit du plancher, et ensuite glissez-les vers le bord avant. **Vous pouvez insérer le panneau mural à fenêtre dans quiconque emplacement, sauf les encoignures, le long des bords latéraux.** Attachez les panneaux les un aux autres à l'aide de six (6) vis (ADZ) à chaque jointure.
- Uno por uno, inserte los **paneles murales (AHD y AHH)** en las ranuras a lo largo del borde derecho del piso, y entonces deslízcelos hacia el borde delantero. **Se puede insertar el panel mural para la ventana en cualquier posición, salvo las esquinas, a lo largo de los bordes laterales.** Sujete los paneles entre sí usando seis (6) tornillos (ADZ) a cada juntura.

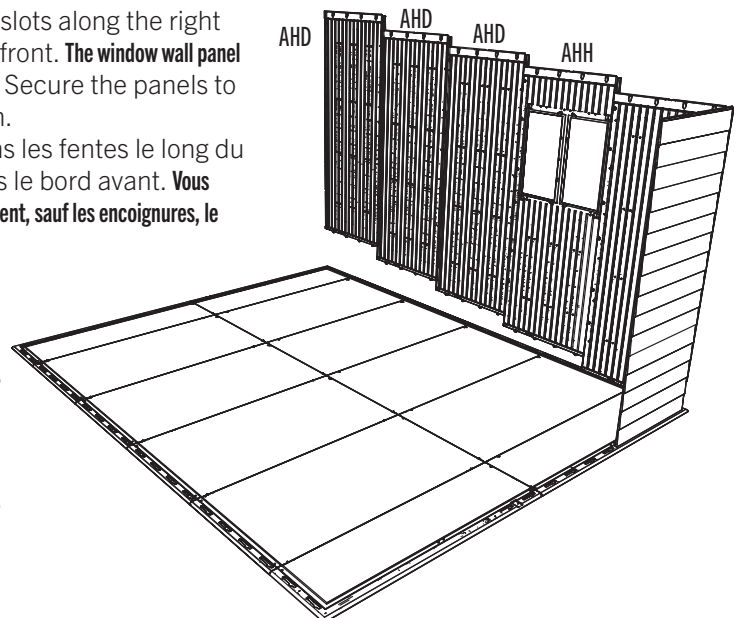

► SECTION 8 (CONTINUED) / SECTION 8 (SUITE) / SECCIÓN 8 (CONTINUACIÓN)

TOOLS AND HARDWARE REQUIRED / OUTILS ET QUINCAILLERIE REQUIS / INSTRUMENTAL Y HERRAJE REQUERIDOS

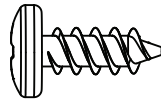

ADZ (x30)

8.6

- Secure the two corner panels together using a **corner channel (AFR)** and twelve (12) **screws (ADZ)**.
- Attachez les deux panneaux l'un à l'autre à l'aide d'un **canal angulaire (AFR)** et douze (12) **vis (ADZ)**.
- Sujete los dos paneles entre sí usando un **canal angular (AFR)** y doce (12) **tornillos (ADZ)**.

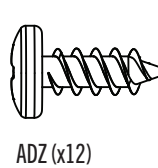

ADZ (x12)

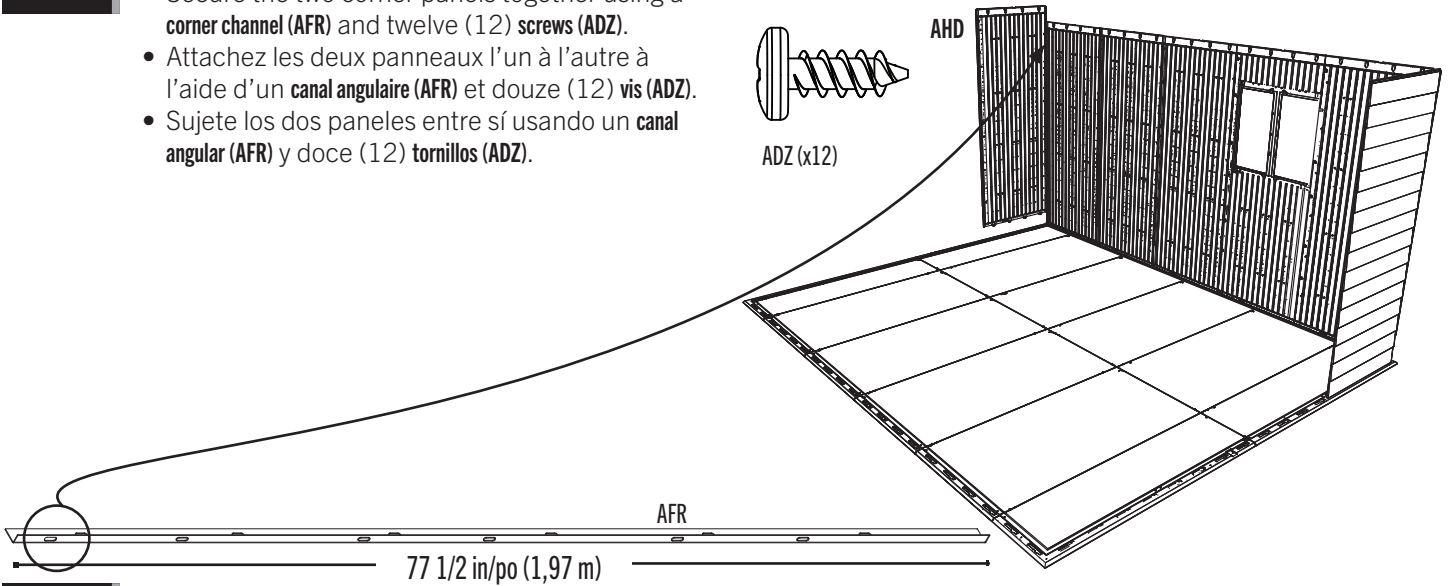

8.7

- Starting at the right, attach the next three wall panels along the rear of the floor, and secure them together using six (6) **screws (ADZ)** at each seam.
- En commençant au côté droit, attachez les trois panneaux muraux suivants le long du bord arrière du plancher. Attachez les panneaux les uns aux autres à l'aide de six (6) **vis (ADZ)** à chaque jointure.
- Empezando al lado derecho, sujete los próximos tres paneles murales a lo largo del borde trasero del piso, y sujételos usando seis (6) **tornillos (ADZ)** a cada juntura.

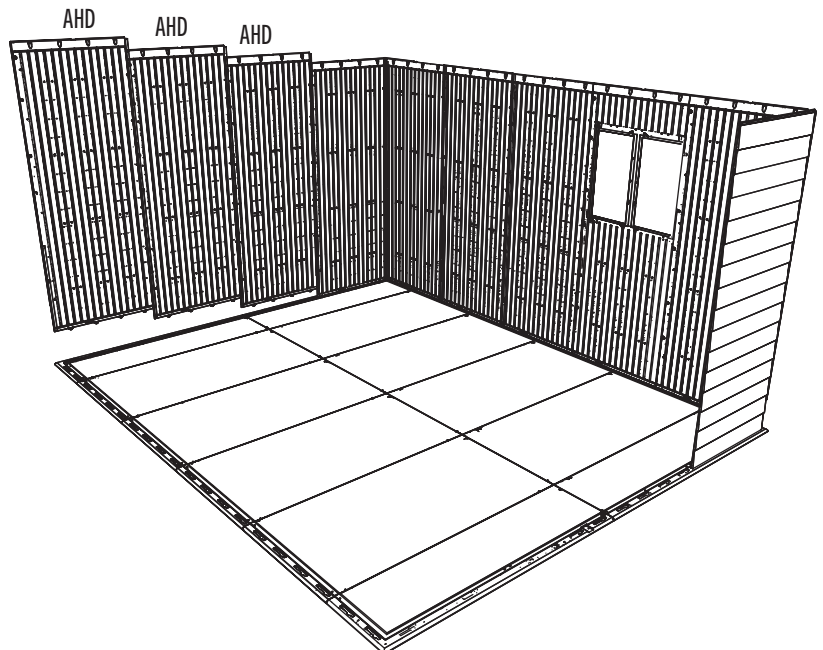

► SECTION 8 (CONTINUED) / SECTION 8 (SUITE) / SECCIÓN 8 (CONTINUACIÓN)

TOOLS AND HARDWARE REQUIRED / OUTILS ET QUINCAILLERIE REQUIS / INSTRUMENTAL Y HERRAJE REQUERIDOS

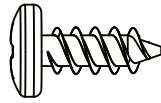

ADZ (x48)

8.8

- Insert the tabs at the bottom of a wall panel into the four slots along the left edge of the floor, and slide the panel to the rear. Secure the two corner panels together using a **corner channel (AFR)** and twelve (12) **screws (ADZ)**.
- Insérez les languettes au bord inférieur du panneau mural dans les quatre rainures le long du bord gauche du plancher, et glissez le panneau vers l'arrière du plancher. Attachez les deux panneaux du coin l'un à l'autre à l'aide d'un **canal angulaire (AFR)** et douze (12) **vis (ADZ)**.
- Introduzca las lengüetas al borde inferior de un panel mural en las cuatro ranuras a lo largo del borde izquierdo del piso, y deslice el panel hacia atrás. Sujete los dos paneles de la entre sí usando un **canal angular (AFR)** y doce (12) **tornillos (ADZ)**.

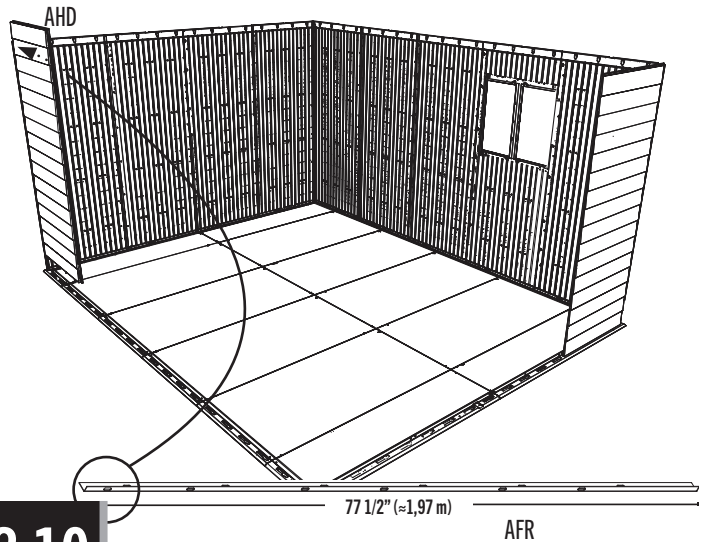

8.9

- Attach these **wall panels (AHD & AHH)** to the floor. **The window wall panel may be placed in any non-corner position along the sides of the shed.** Secure the panels together.
- Attachez ces **panneaux muraux (AHD et AHH)** au plancher. **Vous pouvez insérer le panneau mural à fenêtre dans quiconque emplacement, sauf les encoignures, le long des bords latéraux.** Attachez les panneaux les un aux autres.
- Sujete estos **paneles murales (AHD y AHH)** al piso. **Se puede insertar el panel mural para la ventana en cualquier posición, salvo las esquinas, a lo largo de los bordes laterales.** Sujete los paneles los entre sí.

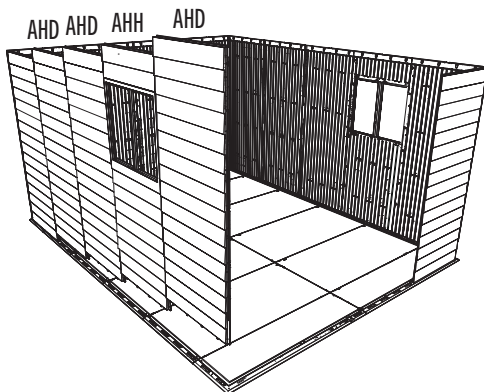

8.10

- Attach the last wall panel to the floor, and secure the two corner panels together using a **corner channel (AFR)** and twelve (12) **screws (ADZ)**.
- Attachez le dernier panneau mural au plancher, et attachez les deux panneaux l'aide d'un **canal angulaire (AFR)** et douze (12) **vis (ADZ)**.
- Sujete el último panel mural al piso, y sujete los dos paneles usando un **canal angular (AFR)** y doce (12) **tornillos (ADZ)**.

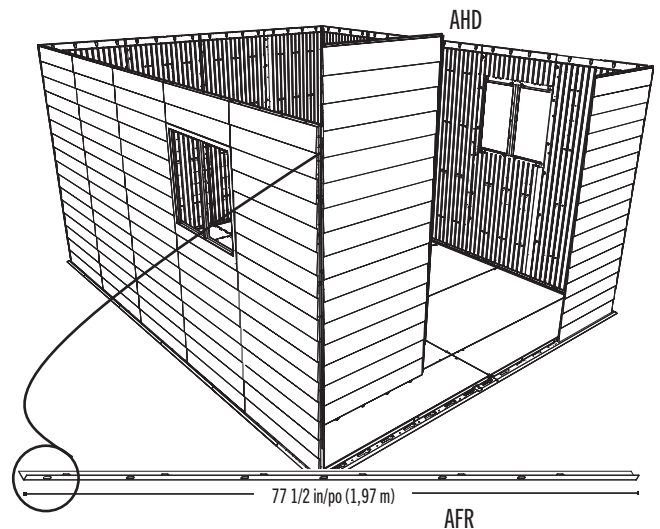

9

TRUSS INSTALLATION / INSTALLATION DES FERMES / INSTALACIÓN DE LAS CERCHAS



HARDWARE REQUIRED / QUINCAILLERIE REQUISE / HERRAJE REQUERIDO

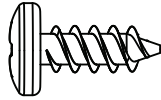

ADZ (x128)

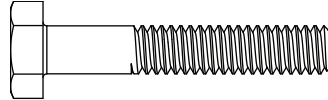

AAK (x18)



ADJ (x18)

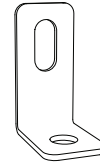

AHT (x6)



PARTS REQUIRED / PIÈCES REQUISES / PIEZAS REQUERIDAS

Metal parts / Pièces en métal / Piezas de metal



AFQ (x6)

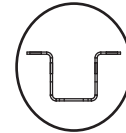

AFJ (x2)

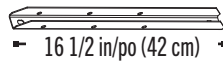

AFN (x4)

Previously assembled parts / Pièces déjà assemblées / Piezas previamente ensambladas

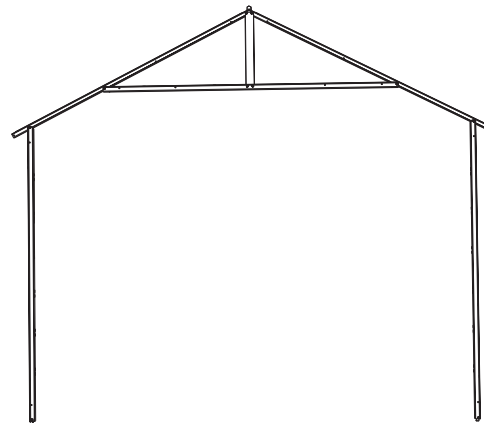

(x5)



TOOLS REQUIRED / OUTILS REQUIS / INSTRUMENTAL REQUERIDO



7/16 in/po (≈11 mm) (x2)

► SECTION 9 (CONTINUED) / SECTION 9 (SUITE) / SECCIÓN 9 (CONTINUACIÓN)

TOOLS AND HARDWARE REQUIRED / OUTILS ET QUINCAILLERIE REQUIS / INSTRUMENTAL Y HERRAJE REQUERIDOS

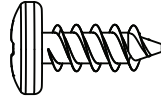

ADZ (x76)

9.1

- One by one, place the five (5) trusses in the centers of opposite wall panels (regular and window). Align the holes, and secure with eight (8) **screws (ADZ)** per truss for a regular wall panel and six (6) **screws (ADZ)** per truss on a window wall panel.
- Un par un, mettez les cinq (5) fermes aux centres des panneaux muraux opposés (les normaux et ceux pour la fenêtre). Alignez les trous, et attachez les fermes aux panneaux à l'aide de huit (8) **vis (ADZ)** par ferme pour un panneau mural normal et six (6) **vis (ADZ)** pour les panneaux muraux pour la fenêtre.
- Uno por uno, coloque las cinco (5) cerchas en los centros de los paneles murales opuestos (los normales y los para las ventanas). Alinee los agujeros, y sujetelos usando ocho (8) **tornillos (ADZ)** por cercha para un panel mural normal y seis (6) **tornillos (ADZ)** por cercha para un panel mural para la ventana.

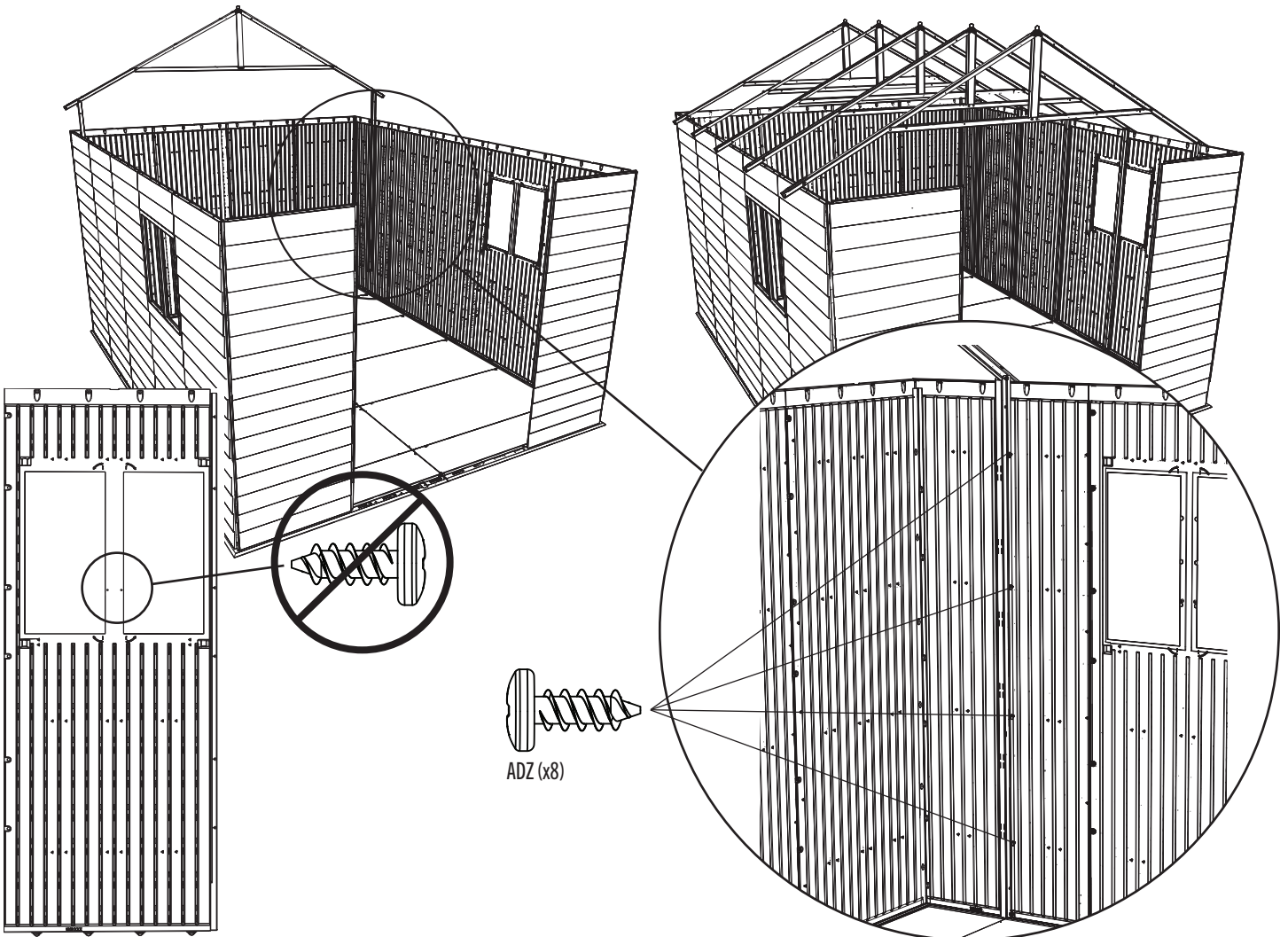

► SECTION 9 (CONTINUED) / SECTION 9 (SUITE) / SECCIÓN 9 (CONTINUACIÓN)

TOOLS AND HARDWARE REQUIRED / OUTILS ET QUINCAILLERIE REQUIS / INSTRUMENTAL Y HERRAJE REQUERIDOS



7/16 in/po (x2)
(≈11 mm)

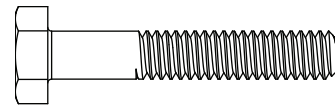

AAK (x12)



ADJ (x12)

9.2

- Place a **short wall channel extension (AFN)** into the top of the wall channel. Secure with two (2) **bolts (AAK)** and two (2) **cap nuts (ADJ)**. **Do not overtighten.**
- Insérez un **rallonge court pour le support mural (AFN)** dans l'extrémité supérieure du support mural. Attachez-le au support à l'aide de deux (2) **boulons (AAK)** et deux (2) **écrous à chape (ADJ)**. **Ne pas trop serrer.**
- Coloque una **extensión corta para el soporte mural (AFN)** dentro del extremo superior del soporte mural. Sujételo usando dos (2) **pernos (AAK)** y dos (2) **tuercas ciegas (ADJ)**. **No apriete demasiado.**

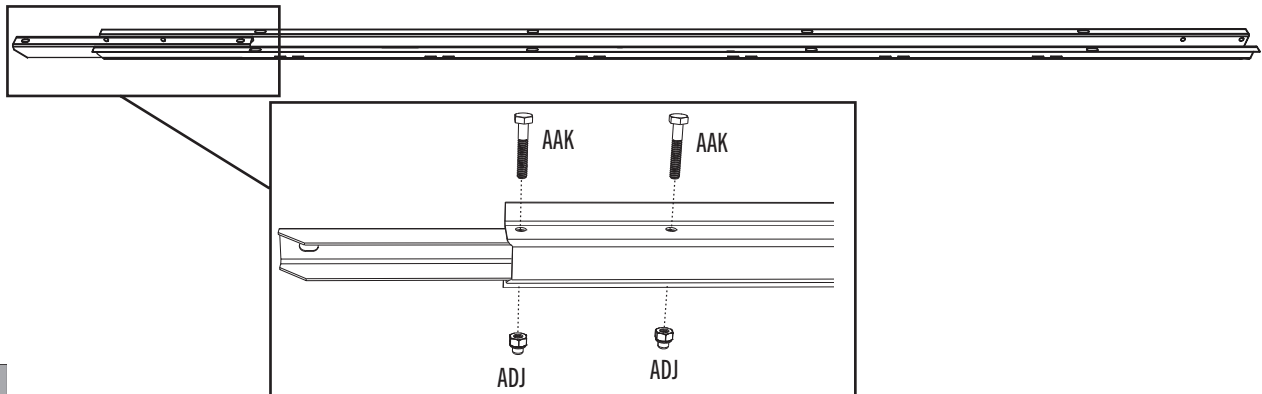
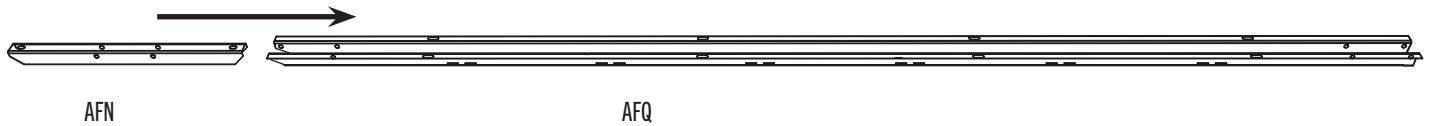

9.3



- Repeat this step three times.
- Répétez cette étape trois fois.
- Repita este paso tres veces.

► SECTION 9 (CONTINUED) / SECTION 9 (SUITE) / SECCIÓN 9 (CONTINUACIÓN)

TOOLS AND HARDWARE REQUIRED / OUTILS ET QUINCAILLERIE REQUIS / INSTRUMENTAL Y HERRAJE REQUERIDOS



7/16 in/po (x2)
(≈11 mm)

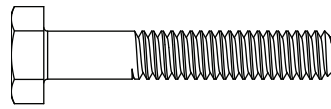

AAK (x12)



ADJ (x12)

9.4

- Place a **long wall channel extension (AFJ)** into the top of the wall channel. Secure with two (2) **bolts (AAK)** and two (2) **cap nuts (ADJ)**. **Do not overtighten.**
- Insérez un **rallonge long pour le support mural (AFJ)** dans l'extrémité supérieure du support mural. Attachez-le au support à l'aide de deux (2) **boulons (AAK)** et deux (2) **écrous à chape (ADJ)**. **Ne pas trop serrer.**
- Coloque una **extensión larga para el soporte mural (AFJ)** dentro del extremo superior del soporte mural. Sujételo usando dos (2) **pernos (AAK)** y dos (2) **tuercas ciegas (ADJ)**. **No apriete demasiado.**

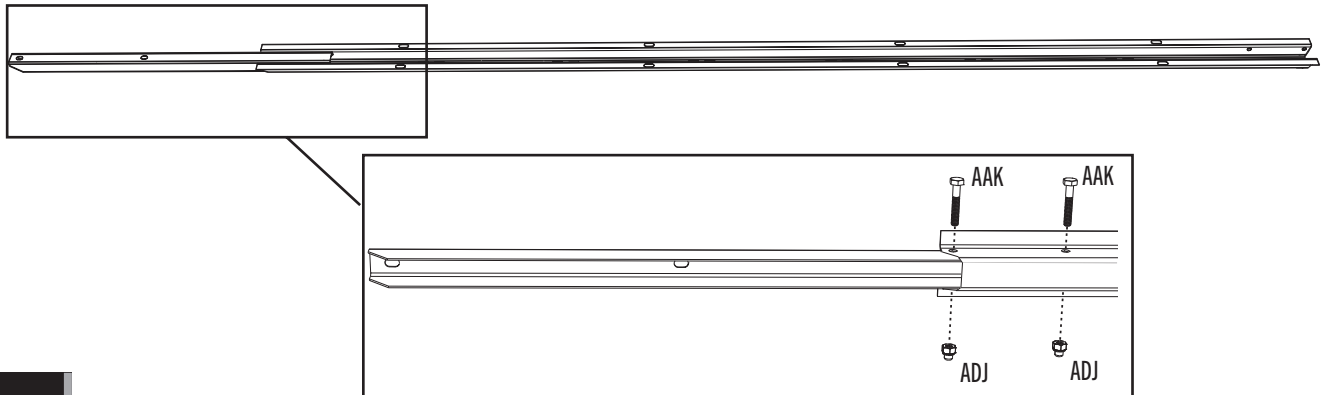
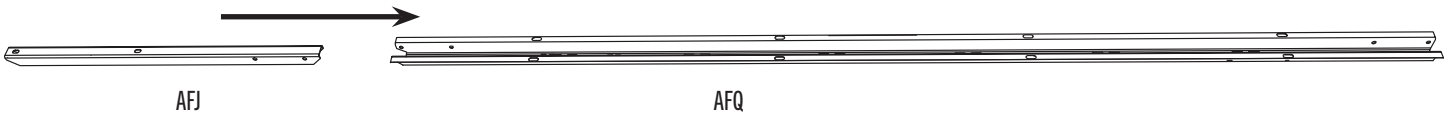

9.5



- Repeat the last step one time.
- Répétez l'étape précédente une fois.
- Repita este paso anterior una vez.

► SECTION 9 (CONTINUED) / SECTION 9 (SUITE) / SECCIÓN 9 (CONTINUACIÓN)

TOOLS AND HARDWARE REQUIRED / OUTILS ET QUINCAILLERIE REQUIS / INSTRUMENTAL Y HERRAJE REQUERIDOS



7/16 in/po (x2)
(≈11 mm)

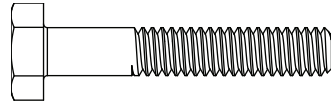

AAK (x6)



ADJ (x6)

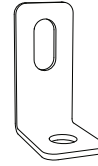

AHT (x6)

9.6

- Secure a **floor bracket (AHT)** to the bottom of the wall channel using one (1) **bolt (AAK)** and one (1) **cap nut (ADJ)**. **Do not overtighten.**
- Attachez **support de plancher (AHT)** à l'extrémité inférieure du support mural à l'aide d'un (1) **boulon (AAK)** et un (1) **écrou à chape (ADJ)**. **Ne pas trop serrer.**
- Sujete un **soporte del piso (AHT)** al extremo inferior del soporte mural usando un (1) **perno (AAK)** y una (1) **tuerca ciega (ADJ)**. **No apriete demasiado.**

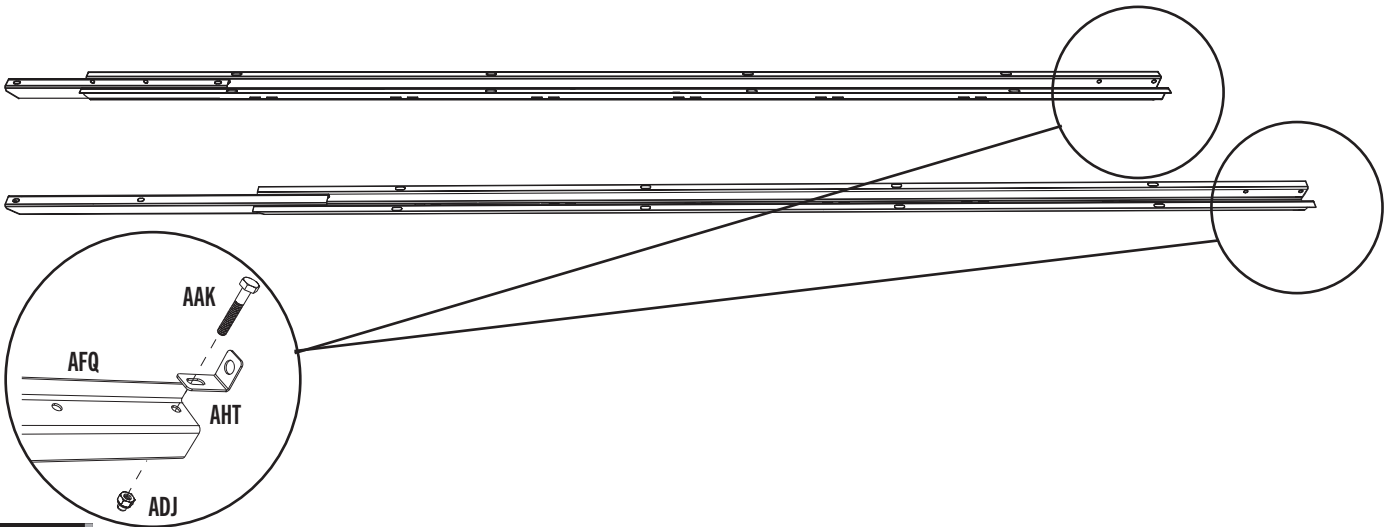

9.7

- Repeat the last step five times.
- Répétez l'étape précédente cinq fois.
- Repita el paso anterior cinco veces.



► SECTION 9 (CONTINUED) / SECTION 9 (SUITE) / SECCIÓN 9 (CONTINUACIÓN)

TOOLS AND HARDWARE REQUIRED / OUTILS ET QUINCAILLERIE REQUIS / INSTRUMENTAL Y HERRAJE REQUERIDOS

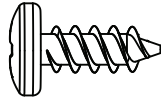

ADZ (x16)

9.8

FRONT WALL PANELS / PANNEAUX MURAUX AVANTS / PANELES MURALES DELANTEROS

- Secure a wall support channel (with a short extension) to each of the front, corner wall panels as shown. **Do not overtighten.**
- Attachez un support mural (avec un rallonge court) à chaque panneau mural avant comme illustré. **Ne pas trop serrer.**
- Sujete un soporte mural (con una extensión corta) a cada panel mural delantero como se muestra. **No apriete demasiado.**

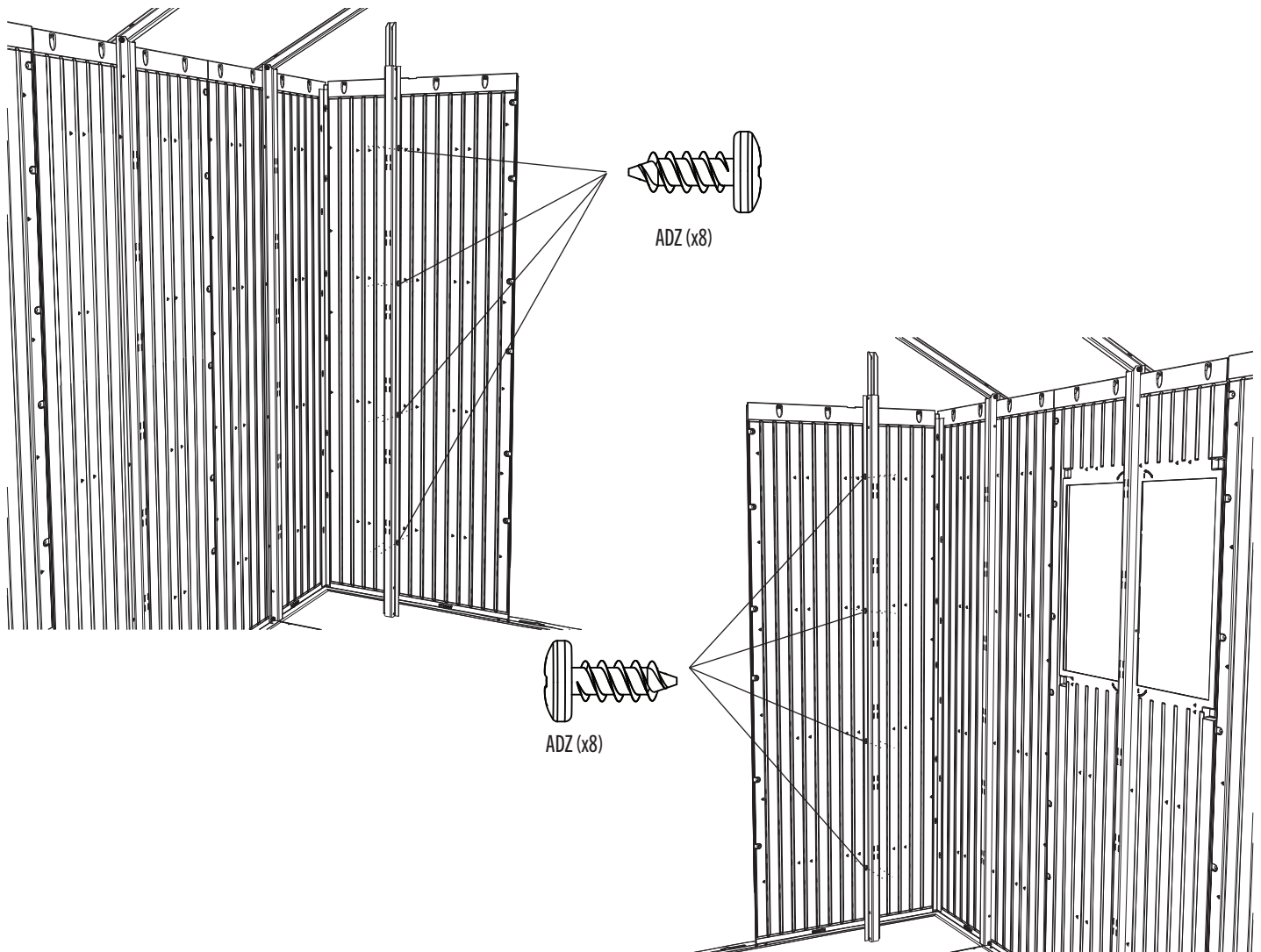

► SECTION 9 (CONTINUED) / SECTION 9 (SUITE) / SECCIÓN 9 (CONTINUACIÓN)

TOOLS AND HARDWARE REQUIRED / OUTILS ET QUINCAILLERIE REQUIS / INSTRUMENTAL Y HERRAJE REQUERIDOS

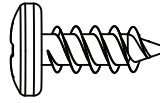

ADZ (x32)

9.9

REAR WALL PANELS / PANNEAUX MURAUX ARRIÈRES / PANELES MURALES TRASEROS

- Secure a wall support channel (with a short extension) to each of the rear, corner wall panels as shown. **Do not overtighten.** Secure a wall support channel (with a long extension) to each of the rear, center wall panels as shown. **Do not overtighten.**
- Attachez un support mural (avec un rallonge court) à chaque panneau mural arrière latéral comme illustré. **Ne pas trop serrer.** Attachez un support mural (avec un rallonge long) à chaque panneau mural arrière central comme illustré. **Ne pas trop serrer.**
- Sujete un soporte mural (con una extensión corta) a cada panel mural trasero lateral como se muestra. **No apriete demasiado.** Sujete un soporte mural (con una extensión larga) a cada panel mural trasero central como se muestra. **No apriete demasiado.**



Short / Court / Corto

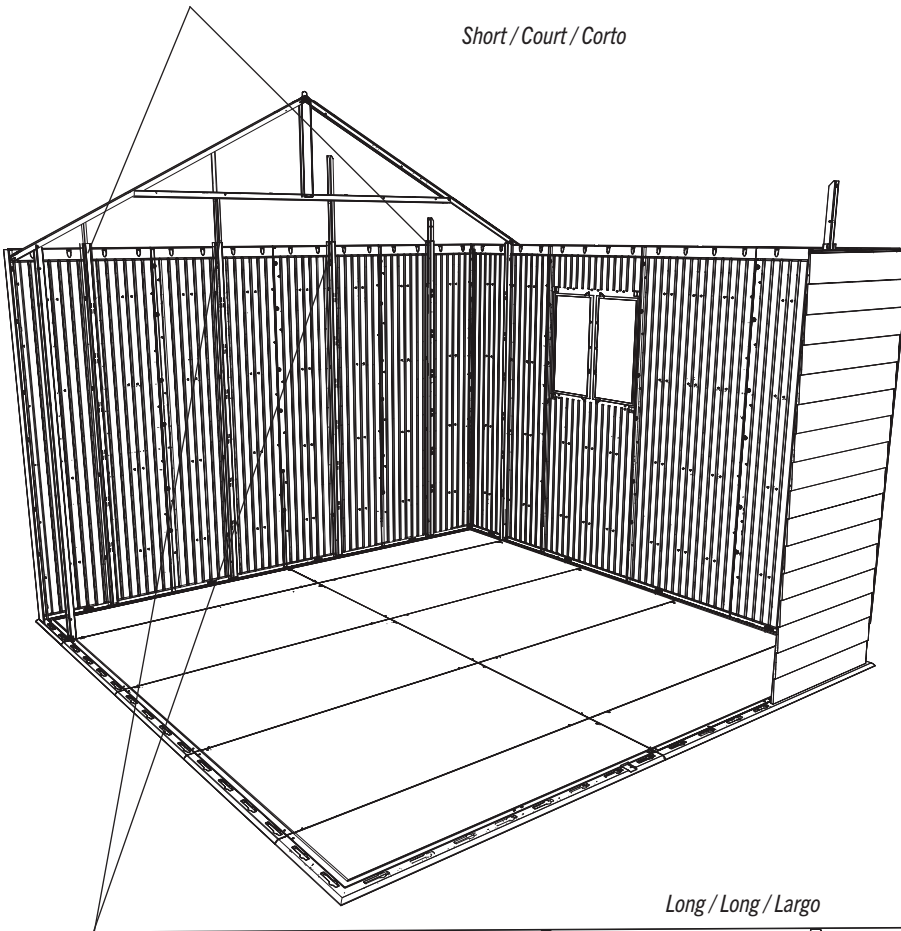

Long / Long / Largo





HARDWARE REQUIRED / QUINCAILLERIE REQUISE / HERRAJE REQUERIDO

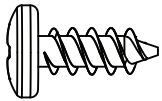
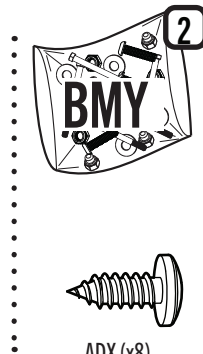

ADZ (x70)



AIY (x10)



ADX (x8)

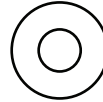

AEE (x8)



PARTS REQUIRED / PIÈCES REQUISES / PIEZAS REQUERIDAS

Metal parts / Pièces en métal / Piezas de metal



AIZ (x4)

Plastic parts / Pièces en plastique / Piezas de plástico



AFS (x5)



AFT (x2)



TOOLS REQUIRED / OUTILS REQUIS / INSTRUMENTAL REQUERIDO

(Not included—unless otherwise indicated) / (Non inclus — sauf indication contraire*) / (No incluido, salvo indicación contraria*)*



► SECTION 10 (CONTINUED) / SECTION 10 (SUITE) / SECCIÓN 10 (CONTINUACIÓN)

TOOLS AND HARDWARE REQUIRED / OUTILS ET QUINCAILLERIE REQUIS / INSTRUMENTAL Y HERRAJE REQUERIDOS



AIY (x10)

10.1

10 in/po x 30 in/po (25,4 cm x 76,2 cm) (AFS)

- Decide where you would like to place your 10" (≈25,4 cm) shelves. Insert two **shelf brackets (AIY)** into opposite slots in the shelf support channels as shown.
- Décidez où vous voudriez placer vos étagères de ≈25,4 cm (10 po). Insérez deux **équerres (AIY)** dans les fentes opposées dans les canaux de support comme illustré.
- Decida donde le gustaría colocar los estantes de ≈25,4 cm (10 in.). Inserte dos **escuadras (AIY)** en las ranuras opuestas en los canales de soporte como se muestra.

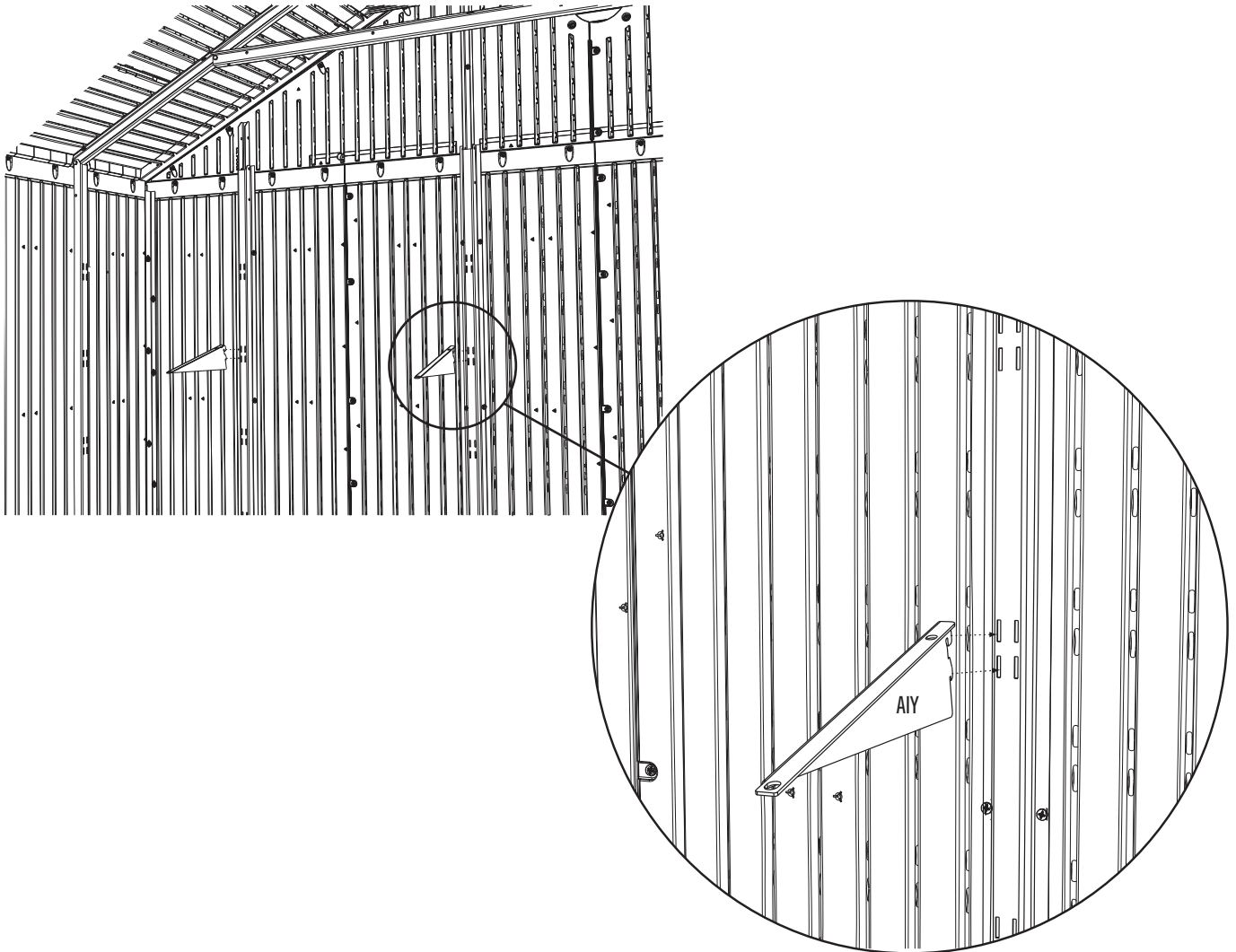



*THIS PAGE INTENTIONALLY LEFT BLANK
CETTE PAGE A ÉTÉ INTENTIONNELLEMENT LAISSÉE EN BLANC
ESTA PÁGINA SE HA DEJADO EN BLANCO INTENCIONADAMENTE*

Remove this section for quick reference / Enlever cette section pour référence rapide / Retirar esta sección para referencia rápida



PARTS IDENTIFIER / IDENTIFICATEUR DE PIÈCES / IDENTIFICADOR DE PIEZAS

CONTENTS OF BOX 1 / CONTENU DE LA BOÎTE 1 / CONTENIDO DE LA CAJA 1

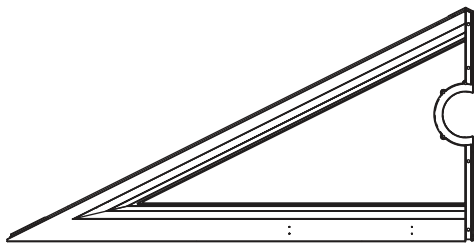

AGI (x2)

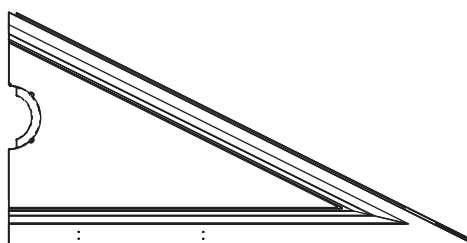

AGH (x2)

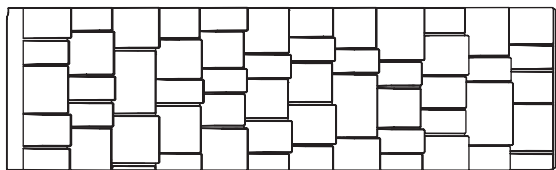

AGU (x2)



AGE (x1)

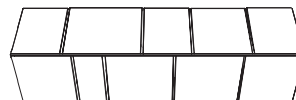

AFY (x2)

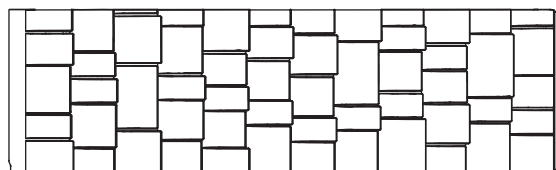

AGV (x2)

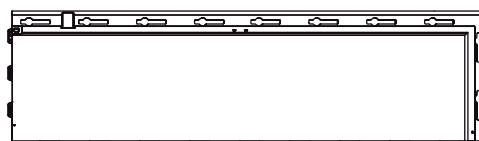

AGT (x2)



AFS (x1)



AFT (x2)

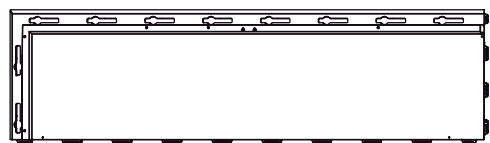

AGS (x2)

CONTENTS OF BOX 1 / CONTENU DE LA BOÎTE 1 / CONTENIDO DE LA CAJA 1

METAL KIT 1 / KIT DE PIÈCES EN MÉTAL 1 / KIT DE PIEZAS DE METAL 1



20 1/8 in/po (51 cm)
AFP (x4)

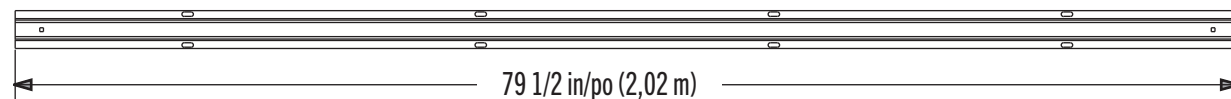

AFG (x2)



AFH (x4)

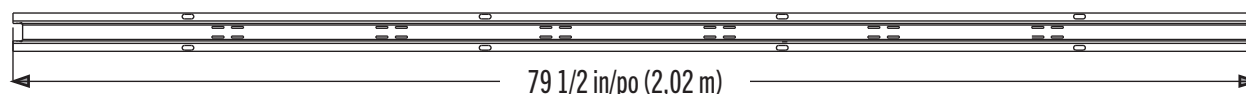
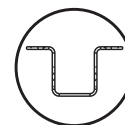

AFQ (x4)

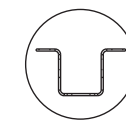

Remove this section for quick reference / Enlever cette section pour référence rapide / Retirar esta sección para referencia rápida



PARTS IDENTIFIER / IDENTIFICATEUR DE PIÈCES / IDENTIFICADOR DE PIEZAS

CONTENTS OF BOX 1 / CONTENU DE LA BOÎTE 1 / CONTENIDO DE LA CAJA 1

METAL KIT 4 / KIT DE PIÈCES EN MÉTAL 4 / KIT DE PIEZAS DE METAL 4



AFI (x2)

CONTENTS OF BOX 2 / CONTENU DE LA BOÎTE 2 / CONTENIDO DE LA CAJA 2

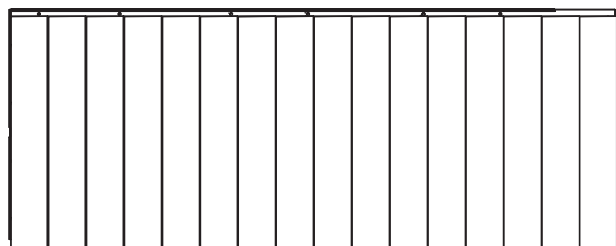

AHD (x3)

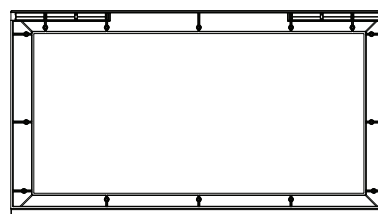

AHG (x2)

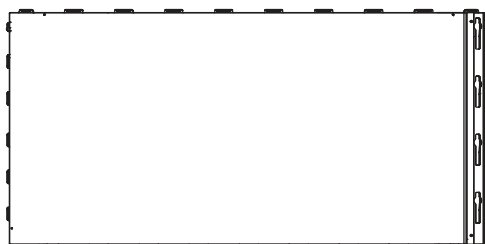

AGJ (x4)

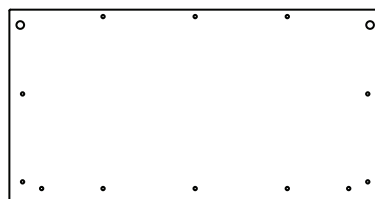

AHF (x2)

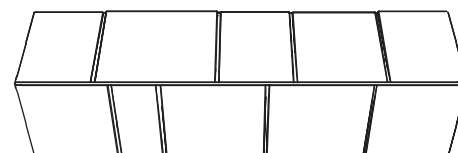

AFY (x1)

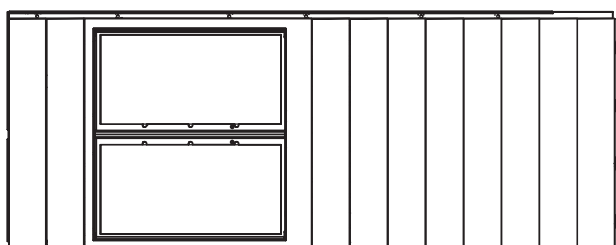

AHH (x1)

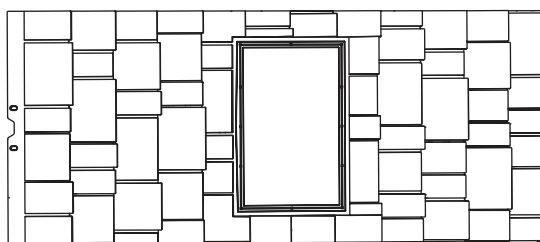

AHB (x1)

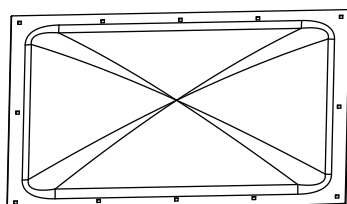

AGB (x2)

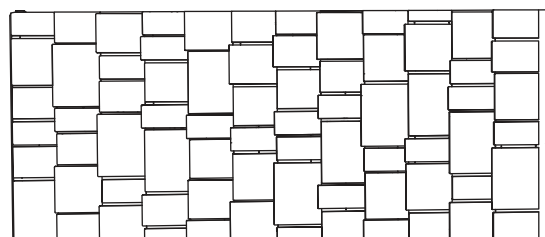

AGQ (x3)

Remove this section for quick reference / Enlever cette section pour référence rapide / Retirar esta sección para referencia rápida



PARTS IDENTIFIER / IDENTIFICATEUR DE PIÈCES / IDENTIFICADOR DE PIEZAS

CONTENTS OF BOX 2 / CONTENU DE LA BOÎTE 2 / CONTENIDO DE LA CAJA 2

METAL KIT 2 / KIT DE PIÈCES EN MÉTAL 2 / KIT DE PIEZAS DE METAL 2

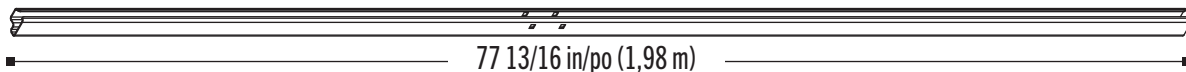
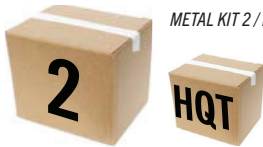

AFC (x2)

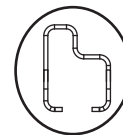

AFR (x4)

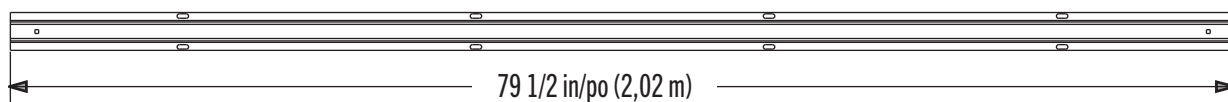

AFG (x1)

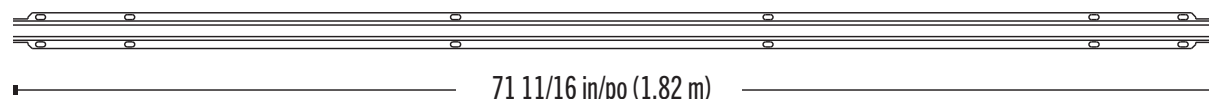

AFH (x2)

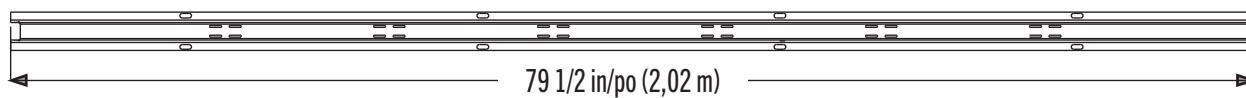
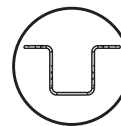

AFQ (x2)

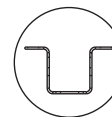

CONTENTS OF BOX 2 / CONTENU DE LA BOÎTE 2 / CONTENIDO DE LA CAJA 2

METAL KIT 3 / KIT DE PIÈCES EN MÉTAL 3 / KIT DE PIEZAS DE METAL 3



AFJ (x2)



AFN (x4)

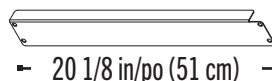

AFP (x2)

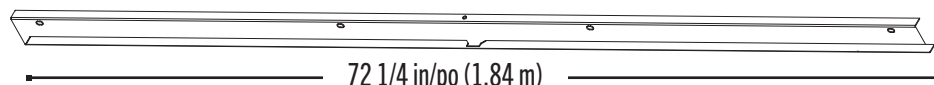

AFD (x1)

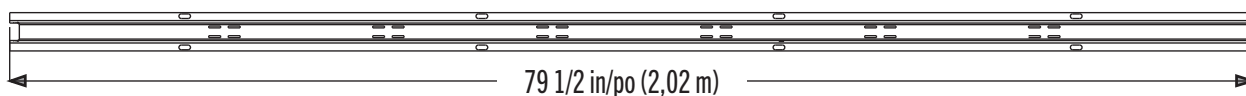

AFQ (x6)

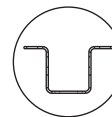

Remove this section for quick reference / Enlever cette section pour référence rapide / Retirar esta sección para referencia rápida



PARTS IDENTIFIER / IDENTIFICATEUR DE PIÈCES / IDENTIFICADOR DE PIEZAS

CONTENTS OF BOX 2 / CONTENU DE LA BOÎTE 2 / CONTENIDO DE LA CAJA 2

SMALL PARTS BOX / BOÎTE DE PETITES PIÈCES / CAJA DE PIEZAS PEQUEÑAS



EGK

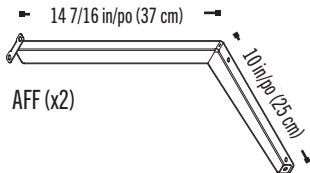

AIZ (x4)

HARDWARE BAGS / BOLSAS DE HERRAJE / SACS D'ACCESSOIRES

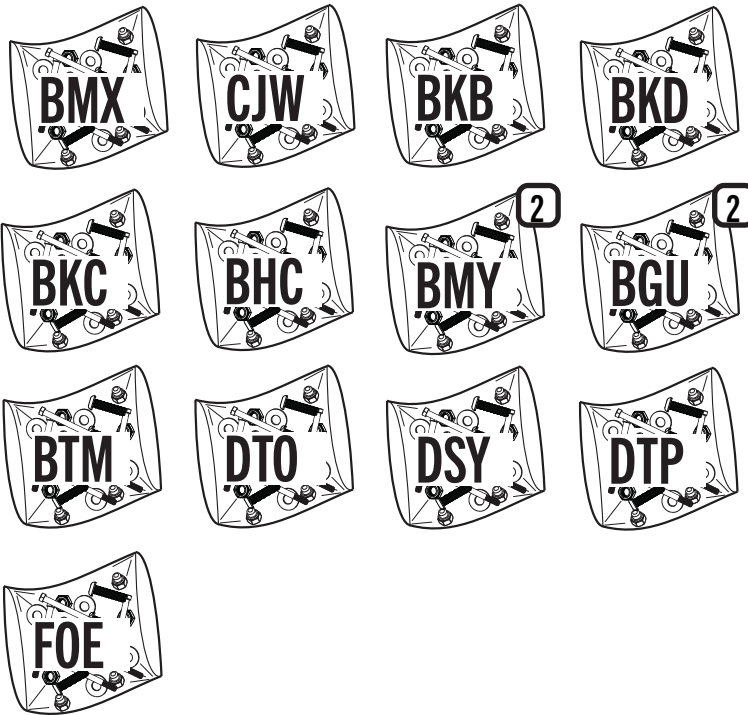

CONTENTS OF BOX 3 / CONTENU DE LA BOÎTE 3 / CONTENIDO DE LA CAJA 3

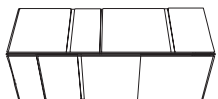

AGE (x1)

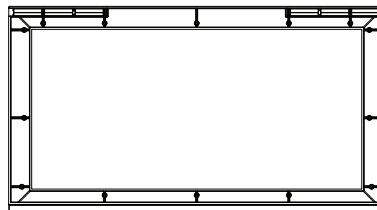

AHG (x2)

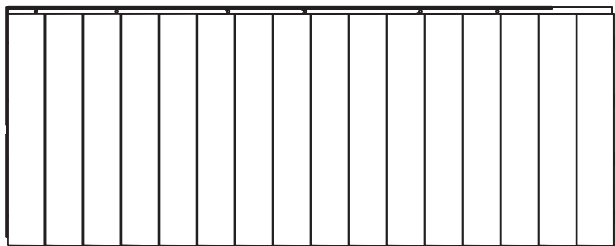

AHD (x3)



AGJ (x4)

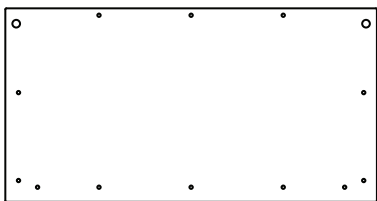

AHF (x2)

Remove this section for quick reference / Enlever cette section pour référence rapide / Retirar esta sección para referencia rápida



PARTS IDENTIFIER / IDENTIFICATEUR DE PIÈCES / IDENTIFICADOR DE PIEZAS

CONTENTS OF BOX 3 / CONTENU DE LA BOÎTE 3 / CONTENIDO DE LA CAJA 3

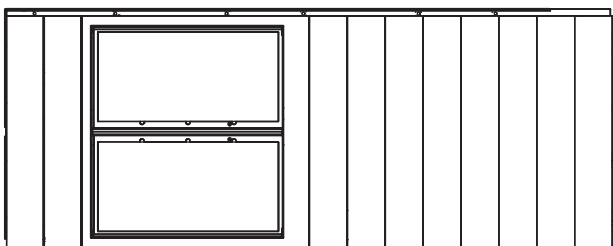

AHH (x1)

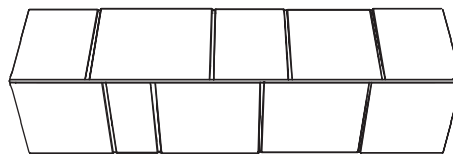

AFY (x1)

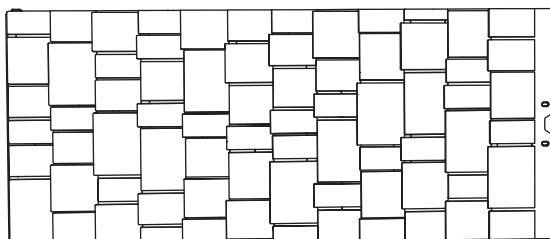

AGQ (x3)

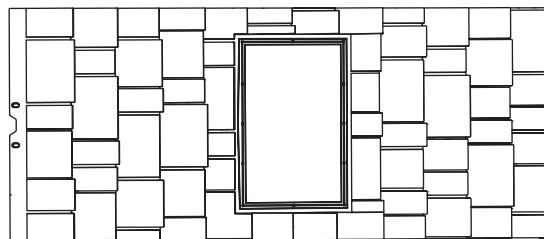

AHB (x1)

CONTENTS OF BOX 3 / CONTENU DE LA BOÎTE 3 / CONTENIDO DE LA CAJA 3

METAL KIT 1 / KIT DE PIÈCES EN MÉTAL 1 / KIT DE PIEZAS DE METAL 1



20 1/8 in/po (51 cm)

AFP (x4)

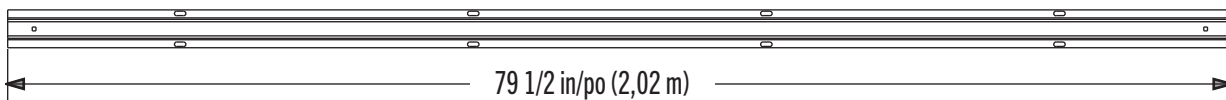

AFG (x2)

79 1/2 in/po (2,02 m)



AFH (x4)

71 11/16 in/po (1,82 m)

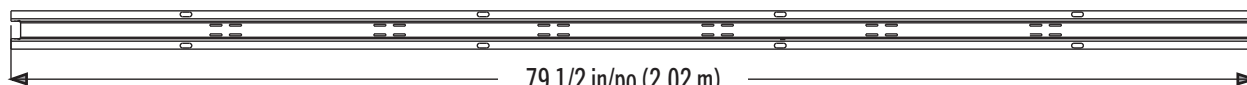
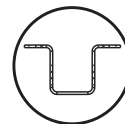

AFQ (x4)

79 1/2 in/po (2,02 m)



Remove this section for quick reference / Enlever cette section pour référence rapide / Retirar esta sección para referencia rápida



PARTS IDENTIFIER / IDENTIFICATEUR DE PIÈCES / IDENTIFICADOR DE PIEZAS

CONTENTS OF BOX 3 / CONTENU DE LA BOÎTE 3 / CONTENIDO DE LA CAJA 3

SMALL PARTS BOX / BOÎTE DE PETITES PIÈCES / CAJA DE PIEZAS PEQUEÑAS

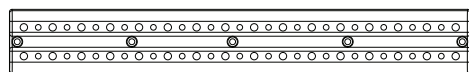

AFU (x2)

HARDWARE BAGS / SACS DE QUINCAILLERIE / BOLSAS DE HERRAJE

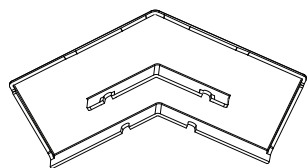

AHA (x2)

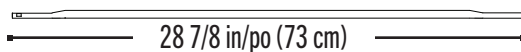

AFL (x24)

28 7/8 in/po (73 cm)

EGL

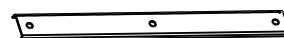

18 1/2 in/po (47 cm)

AFB (x6)

CONTENTS OF BOX 4 / CONTENU DE LA BOÎTE 4 / CONTENIDO DE LA CAJA 4

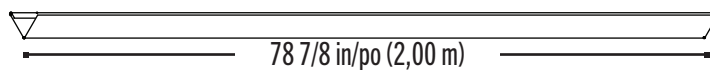

AQX (x4)

78 7/8 in/po (2,00 m)

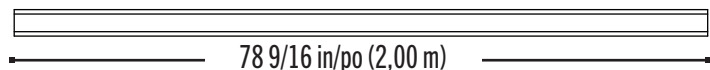

AGD (x2)

78 9/16 in/po (2,00 m)

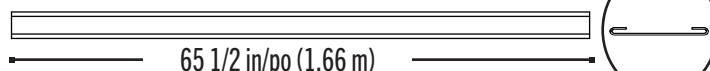
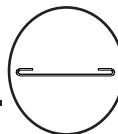

AGC (x1)

65 1/2 in/po (1,66 m)

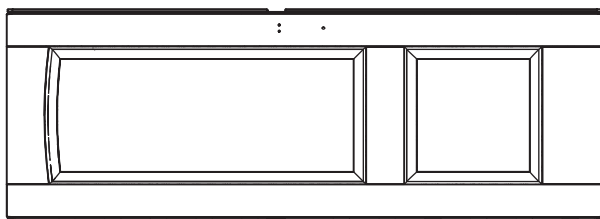
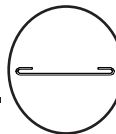

AGO (x1)

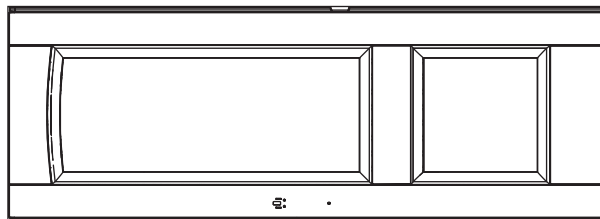

AGZ (x1)

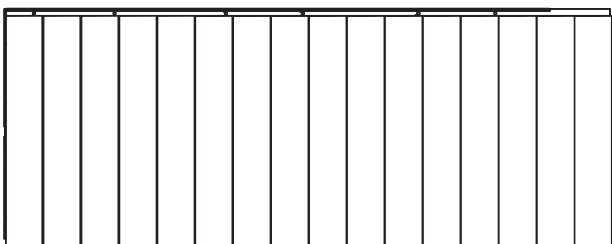

AHD (x8)



AFS (x4)

Remove this section for quick reference / Enlever cette section pour référence rapide / Retirar esta sección para referencia rápida



*THIS PAGE INTENTIONALLY LEFT BLANK
CETTE PAGE A ÉTÉ INTENTIONNELLEMENT LAISSÉE EN BLANC.
ESTA PÁGINA SE HA DEJADO EN BLANCO INTENCIONADAMENTE.*

Remove this section for quick reference / Enlever cette section pour référence rapide / Retirar esta sección para referencia rápida

► SECTION 10 (CONTINUED) / SECTION 10 (SUITE) / SECCIÓN 10 (CONTINUACIÓN)

TOOLS AND HARDWARE REQUIRED / OUTILS ET QUINCAILLERIE REQUIS / INSTRUMENTAL Y HERRAJE REQUERIDOS

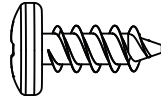

ADZ (x20)

10.2

- Attach a **shelf (AFS)** to the shelf brackets using the hardware indicated.
- Attachez une **étagère (AFS)** aux équerres à l'aide de la quincaillerie indiquée.
- Sujete un **estante (AFS)** a las escuadras usando el herraje indicado.

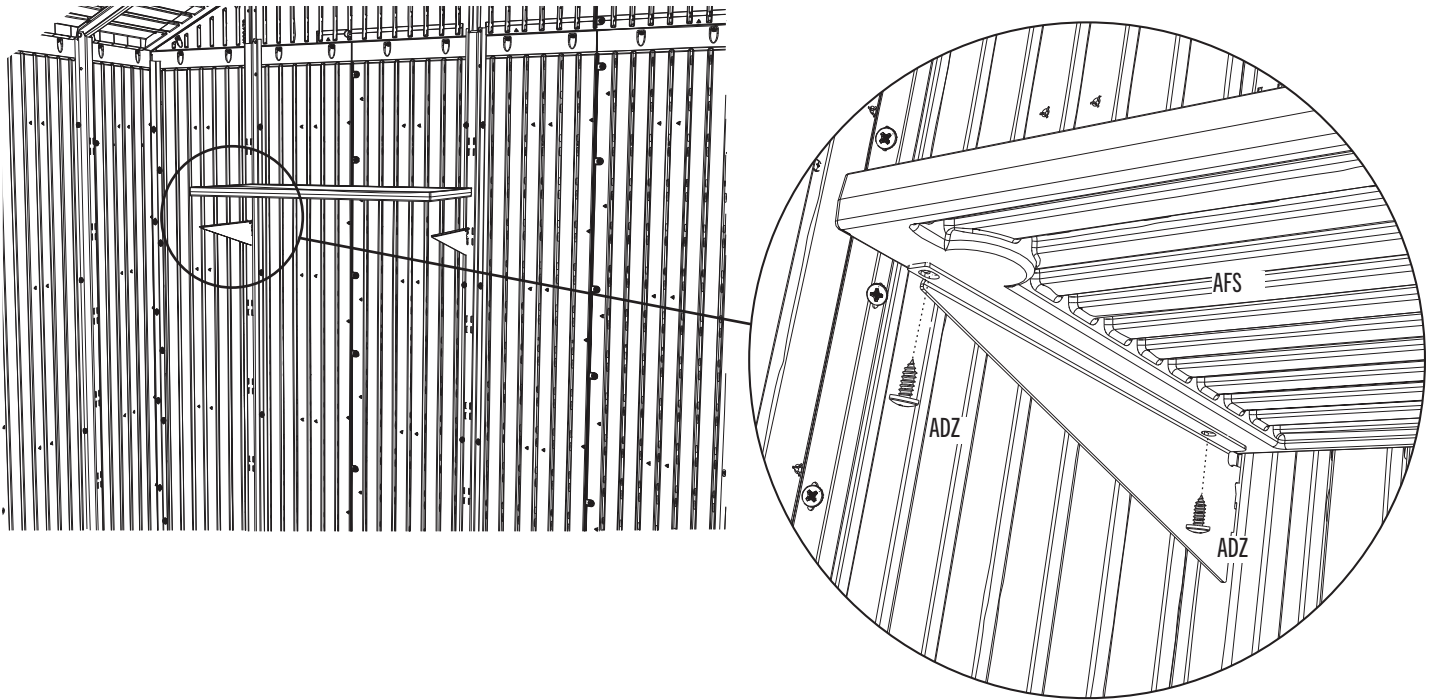

10.3

- Repeat steps 10.1–10.2 for the remaining 10" x 30" (≈25,4 cm x ≈76,2 cm) shelves (AFS).
- Répétez les étapes 10.1 – 10.2 pour les étagères de ≈25,4 cm x ≈76,2 cm (10 po x 30 po) (AFS) restantes.
- Repita los pasos 10.1–10.2 para los estantes de ≈25,4 cm x ≈76,2 cm (10 in. x 30 in.) (AFS) restantes.

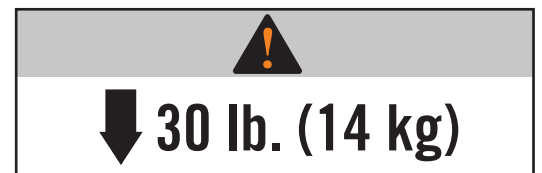

► SECTION 10 (CONTINUED) / SECTION 10 (SUITE) / SECCIÓN 10 (CONTINUACIÓN)

TOOLS AND HARDWARE REQUIRED / OUTILS ET QUINCAILLERIE REQUIS / INSTRUMENTAL Y HERRAJE REQUERIDOS



AIZ (x4)

10.4

14 in/po x 30 in/po (36,6 cm x 76,2 cm) (AFT)

- Decide where you would like to place your 14" ($\approx 36,6$ cm) shelves. Insert two **shelf brackets (AIZ)** into opposite slots in the shelf support channels as shown.
- Décidez où vous voudriez placer vos étagères de $\approx 36,6$ cm (14 po). Insérez deux **équerres (AIZ)** dans les fentes opposées dans les cannaux de support comme illustré.
- Decida donde le gustaría colocar los estantes de $\approx 36,6$ cm (14 in.). Inserte dos **escuadras (AIZ)** en las ranuras opuestas en los canales de soporte como se muestra.

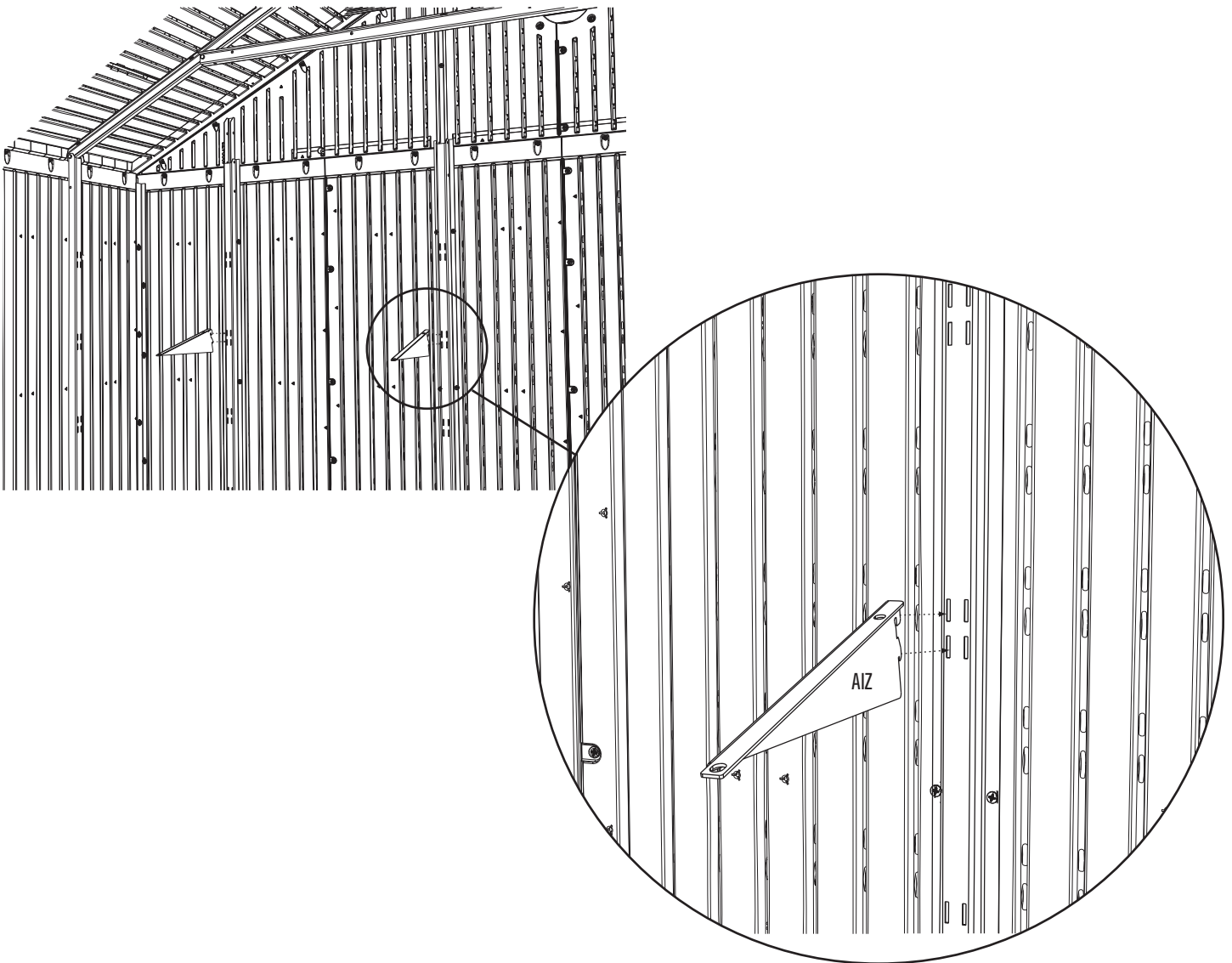

► SECTION 10 (CONTINUED) / SECTION 10 (SUITE) / SECCIÓN 10 (CONTINUACIÓN)

TOOLS AND HARDWARE REQUIRED / OUTILS ET QUINCAILLERIE REQUIS / INSTRUMENTAL Y HERRAJE REQUERIDOS

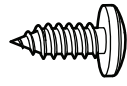

ADX (x8)

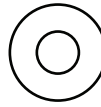

AEE (x8)

10.5

- Attach a **shelf (AFT)** to the shelf brackets using the hardware indicated.
- Attachez une **étagère (AFT)** aux équerres à l'aide de la quincaillerie indiquée.
- Sujete un **estante (AFT)** a las escuadras usando el herraje indicado.

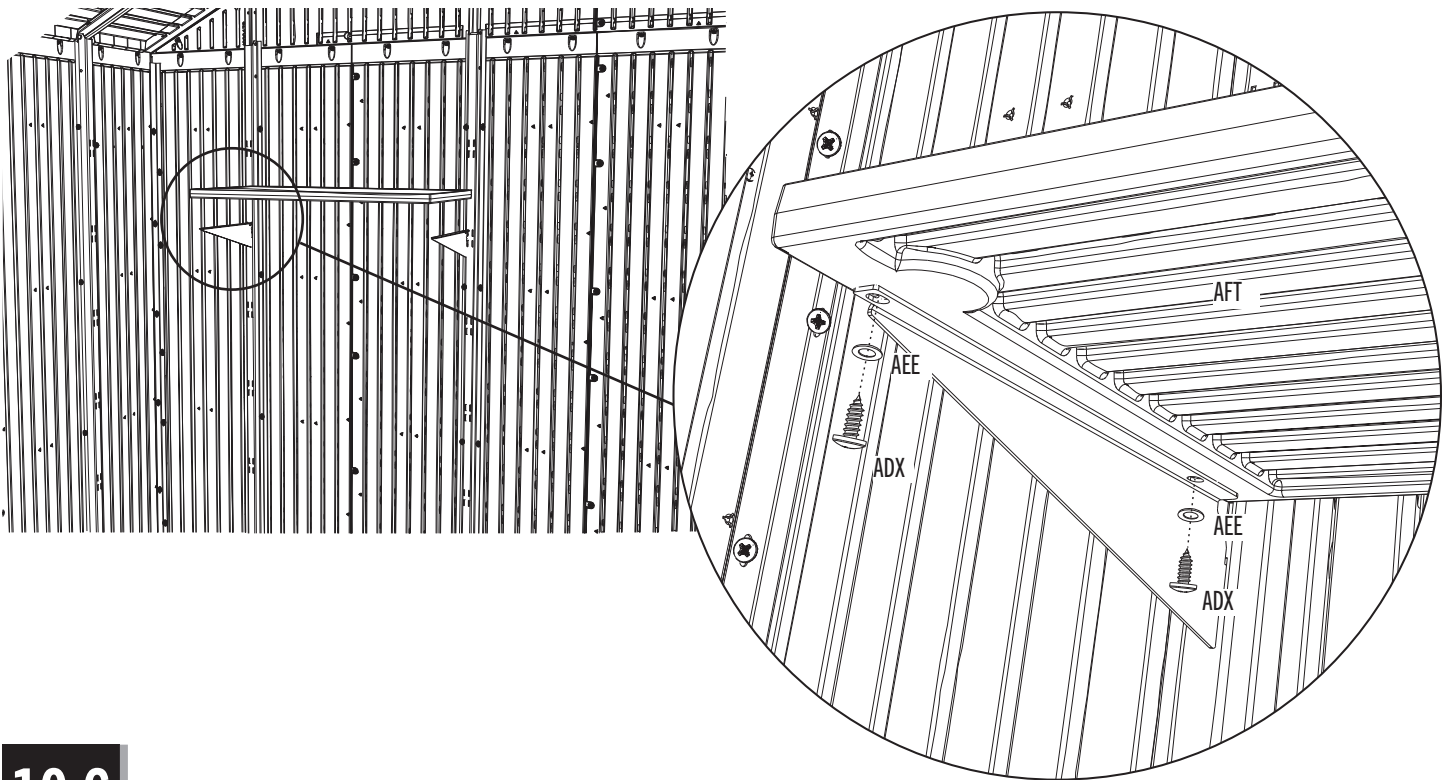

10.6

- Repeat steps 10.4–10.5 for the remaining 14" x 30" (≈36,6 cm x ≈76,2 cm) shelf (AFT).
- Répétez les étapes 10.4 – 10.5 pour l'étagère de ≈36,6 cm x ≈76,2 cm (14 po x 30 po) (AFT) restante.
- Repita los pasos 10.4–10.5 para el estante de ≈36,6 cm x ≈76,2 cm (14 in. x 30 in.) (AFT) restante.





↓ **30 lb. (14 kg)**

11

DOOR & ENTRY GABLE INSTALLATION / INSTALLATION DES PORTES ET LE PIGNON D'ENTRÉE / INSTALACIÓN DE LAS PUERTAS Y LA FACHADA DE ENTRADA

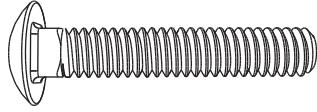

HARDWARE REQUIRED / QUINCAILLERIE REQUISE / HERRAJE REQUERIDO



ACH (x4)

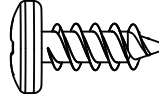

ADZ (x24)



ADX (x2)

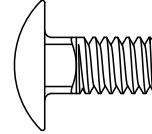

ACA (x4)



ADJ (x8)

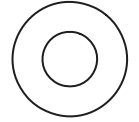

AEB (x4)



AHN (x2)



AHL (x1)



PARTS REQUIRED / PIÈCES REQUISES / PIEZAS REQUERIDAS

Metal parts / Pièces en métal / Piezas de metal

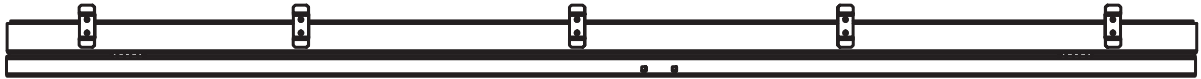

AFI (x2)

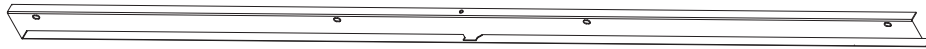

72 1/4 in/po (1,84 m)

AFD (x1)

Plastic parts / Pièces en plastique / Piezas de plástico

Previously assembled parts / Pièces déjà assemblées / Piezas previamente ensambladas

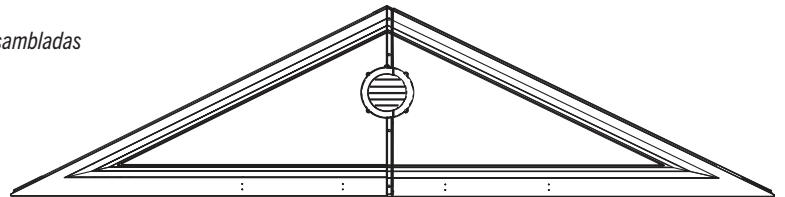

(x1)

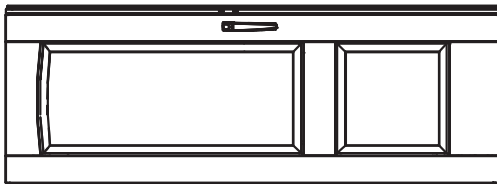

(x1)

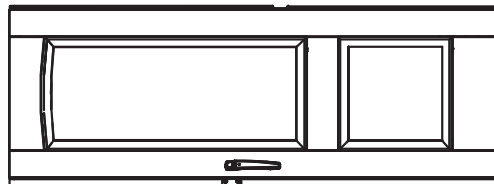

(x1)



TOOLS REQUIRED / OUTILS REQUIS / INSTRUMENTAL REQUERIDO

(Not included—unless otherwise indicated*) / (Non inclus — sauf indication contraire*) / (No incluido, salvo indicación contraria*)



7/16 in/po (≈11 mm)

► SECTION 11 (CONTINUED) / SECTION 11 (SUITE) / SECCIÓN 11 (CONTINUACIÓN)

TOOLS AND HARDWARE REQUIRED / OUTILS ET QUINCAILLERIE REQUIS / INSTRUMENTAL Y HERRAJE REQUERIDOS

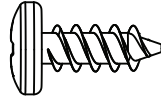

ADZ (x10)

11.1



- Set a gable assembly down onto the two front wall panels as shown.
- Mettez un ensemble du pignon sur les deux panneaux muraux avants comme illustré.
- Coloque un conjunto de la fachada encima de los dos paneles murales delanteros como se muestra.

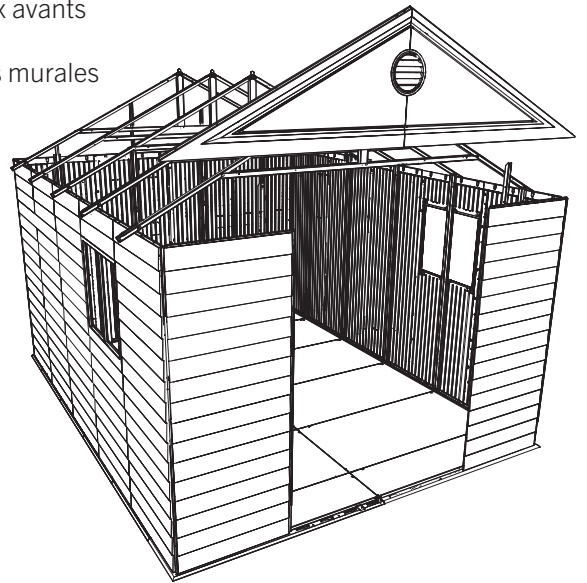

11.2

- Secure the gable to the shed at the locations shown using ten (10) screws (ADZ).
- Attachez bien le pignon à l'abri aux emplacements indiqués à l'aide de dix (10) vis (ADZ).
- Sujete la fachada a la caseta a las ubicaciones indicadas usando diez (10) tornillos (ADZ).

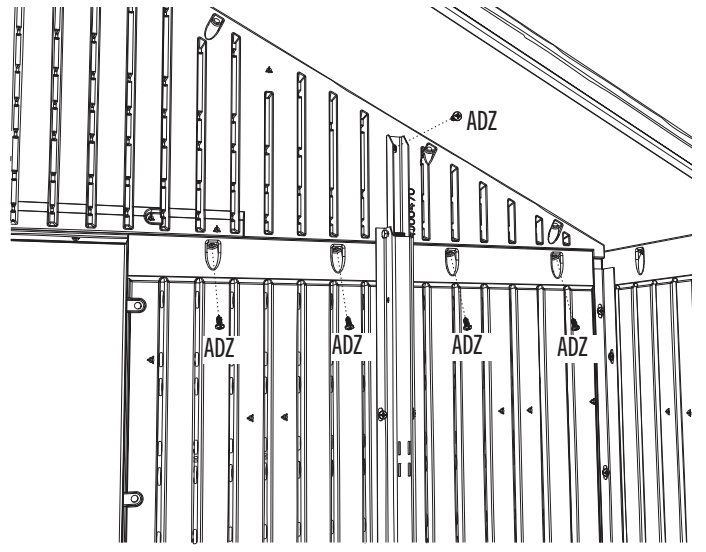
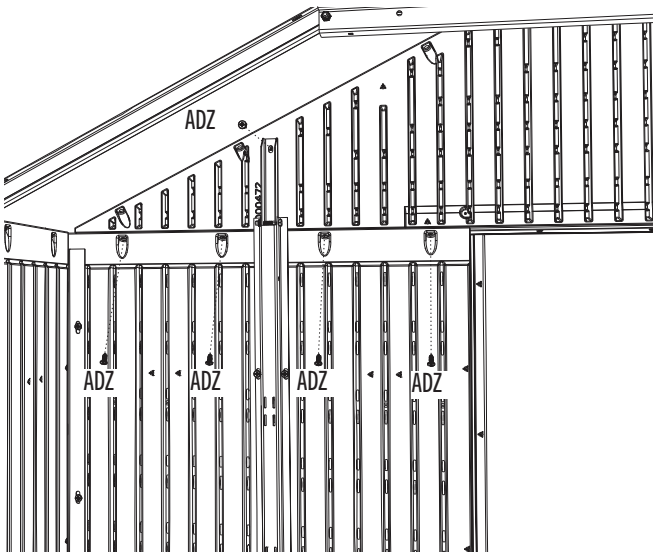

SECTION 11 (CONTINUED) / SECTION 11 (SUITE) / SECCIÓN 11 (CONTINUACIÓN)

TOOLS AND HARDWARE REQUIRED / OUTILS ET QUINCAILLERIE REQUIS / INSTRUMENTAL Y HERRAJE REQUERIDOS



7/16 in/po (x2)
(≈11 mm)



AHN (x1)

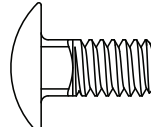

ACA (x2)



ADJ (x2)

11.3

- Attach the following hardware to the **hinge (AFI)** for the right door. **Only hand tighten the top nut (ADJ).**
- Attachez la quincaillerie suivante à la **charnière (AFI)** pour la porte droite. **Serrez l'écrou (ADJ) supérieur à la main seulement.**
- Sujete el herraje siguiente a la **bisagra (AFI)** para la puerta derecha. **Apriete la tuerca (ADJ) superior sólo a mano.**

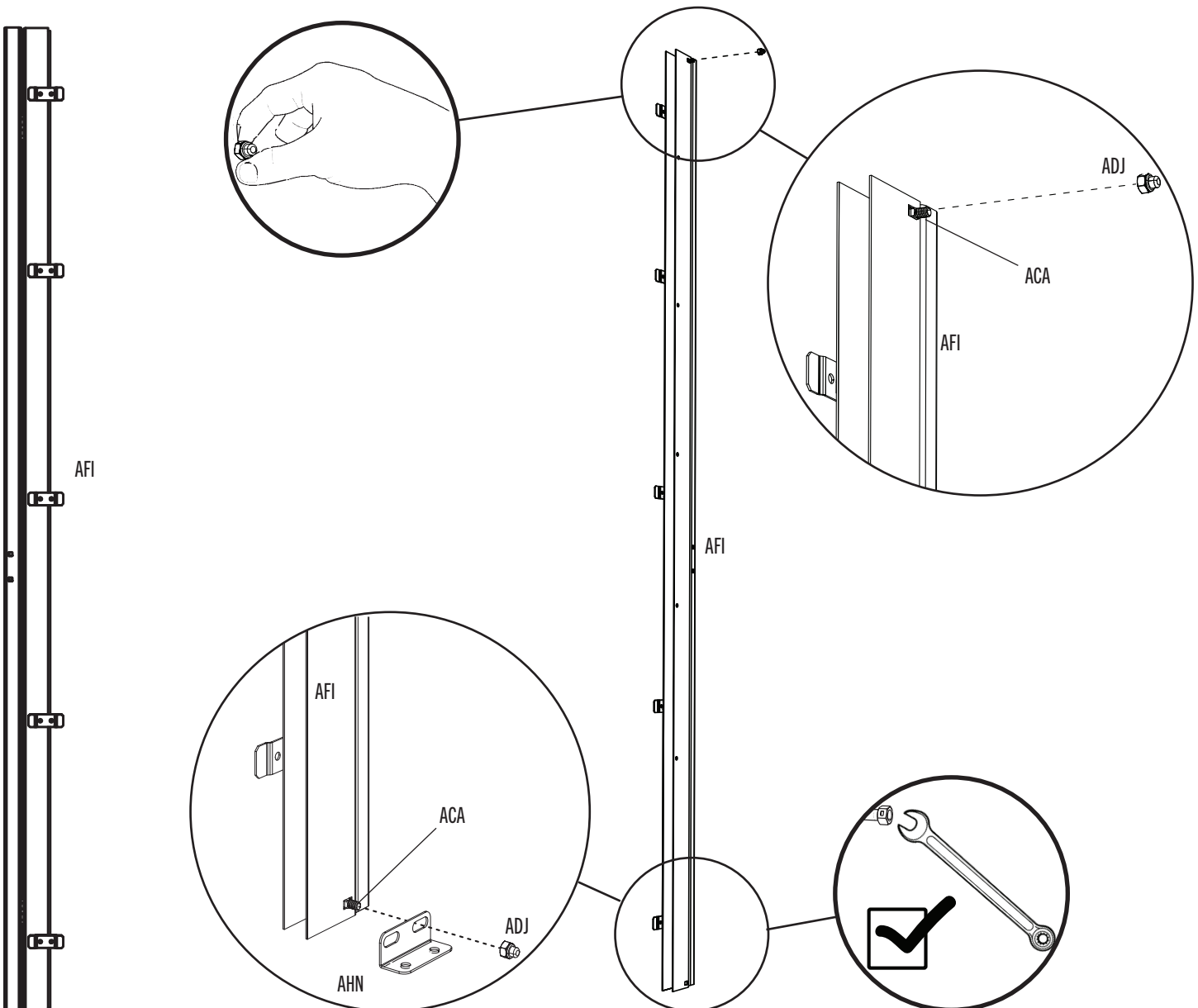

► SECTION 11 (CONTINUED) / SECTION 11 (SUITE) / SECCIÓN 11 (CONTINUACIÓN)

TOOLS AND HARDWARE REQUIRED / OUTILS ET QUINCAILLERIE REQUIS / INSTRUMENTAL Y HERRAJE REQUERIDOS

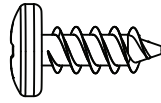

ADZ (x5)

11.4

- Slide the edge of the right hinge over right, front wall panel, align the holes, and secure with five (5) screws (ADZ).
- Glissez le bord de la charnière droite sur le panneau mural droit avant, alignez les trous, et attachez-le à l'aide de cinq (5) vis (ADZ).
- Deslice el borde de la bisagra derecha sobre el panel mural derecho delantero, alinee los agujeros, y sujételo usando cinco (5) tornillos (ADZ).

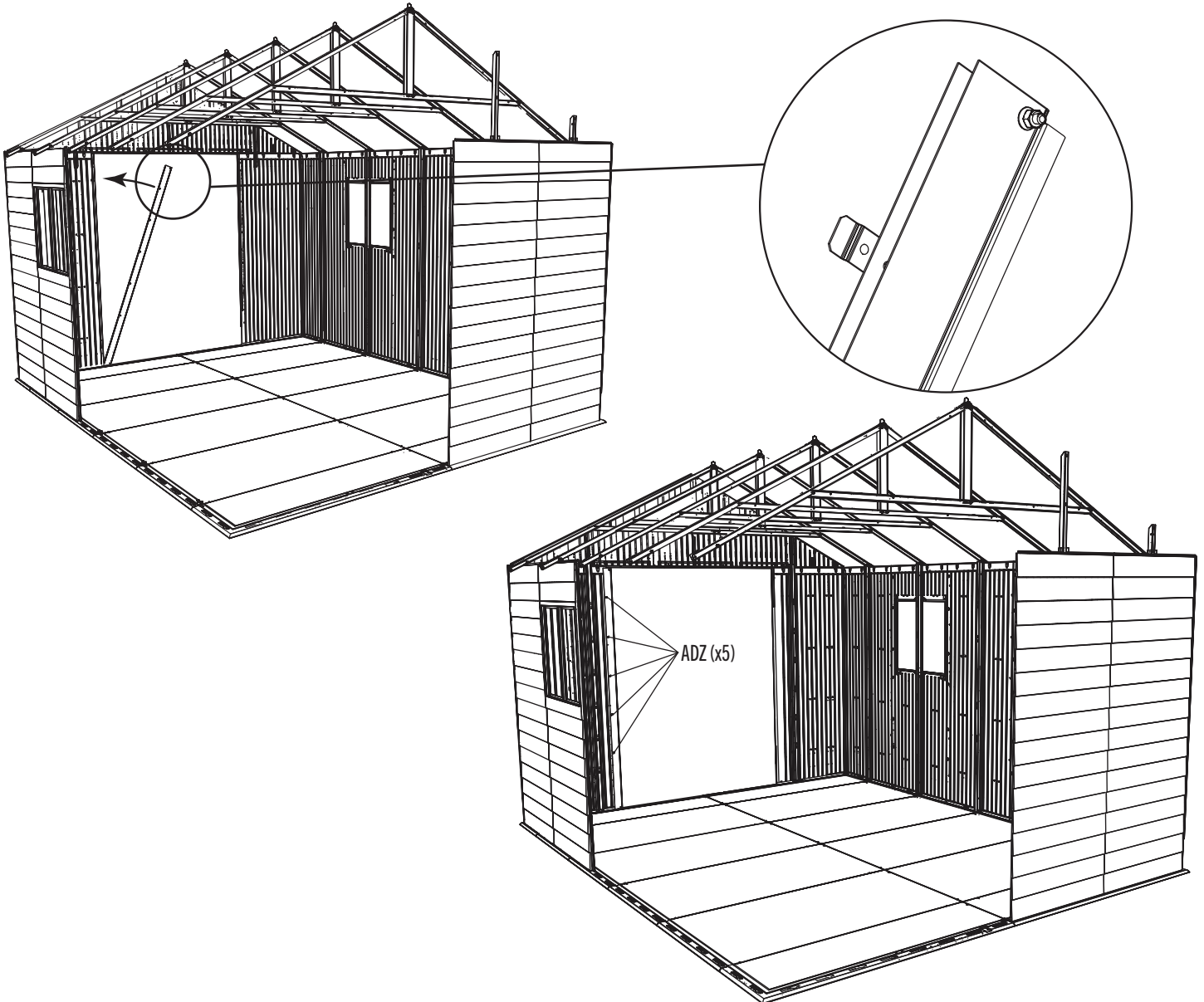

► SECTION 11 (CONTINUED) / SECTION 11 (SUITE) / SECCIÓN 11 (CONTINUACIÓN)

TOOLS AND HARDWARE REQUIRED / OUTILS ET QUINCAILLERIE REQUIS / INSTRUMENTAL Y HERRAJE REQUERIDOS



7/16 in/po (x2)
(≈11 mm)



AHN (x1)

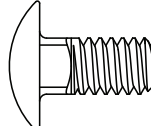

ACA (x2)



ADJ (x2)

11.5

- Attach the following hardware to the **hinge (AFI)** for the left door. Only hand tighten the top **nut (ADJ)**.
- Attachez la quincaillerie suivante à la **charnière (AFI)** pour la porte gauche. Serrez l'**écrou (ADJ)** supérieur à la main seulement.
- Sujete el herraje siguiente a la **bisagra (AFI)** para la puerta izquierda. Apriete la **tuerca (ADJ)** superior sólo a mano.

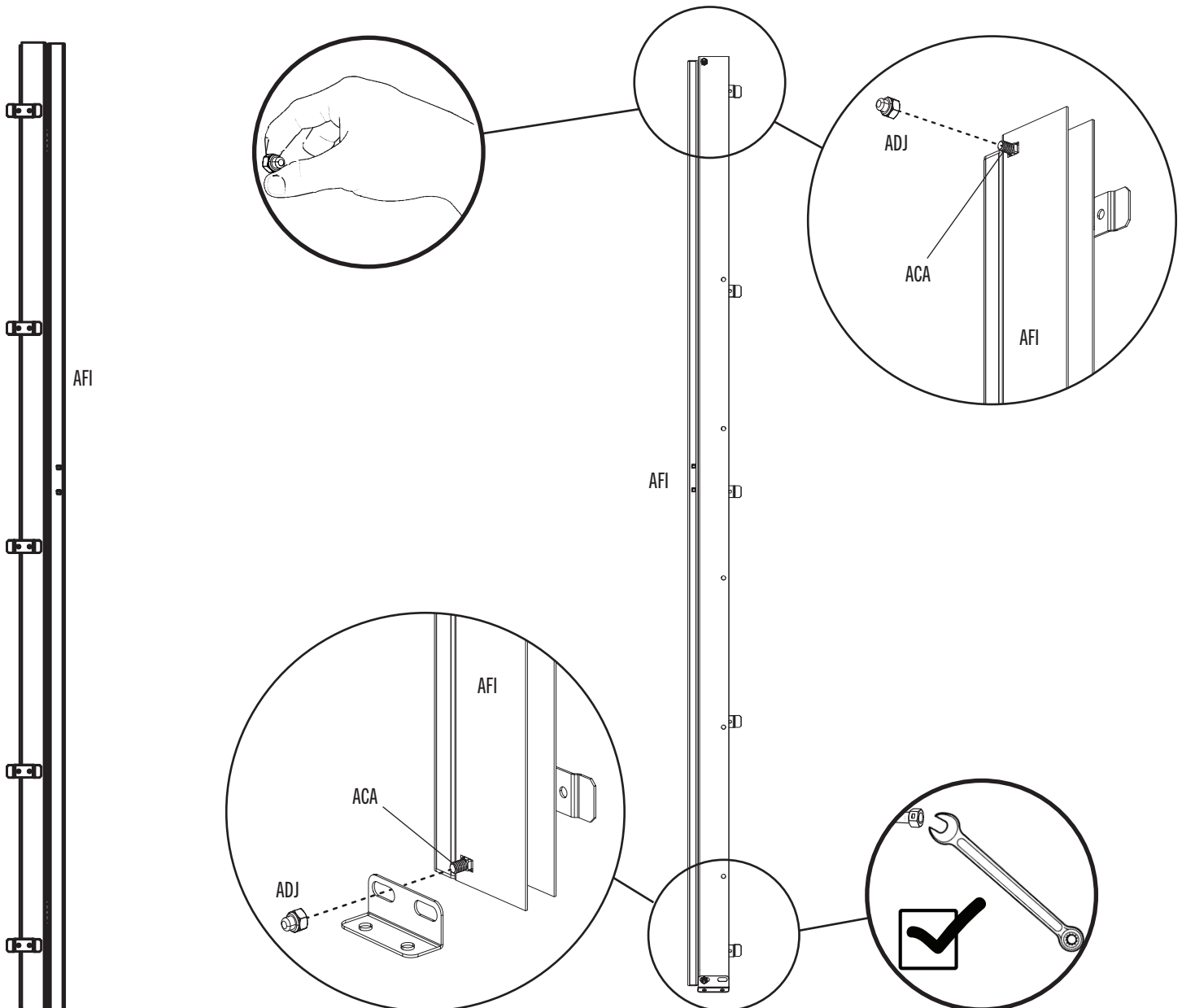

► SECTION 11 (CONTINUED) / SECTION 11 (SUITE) / SECCIÓN 11 (CONTINUACIÓN)

TOOLS AND HARDWARE REQUIRED / OUTILS ET QUINCAILLERIE REQUIS / INSTRUMENTAL Y HERRAJE REQUERIDOS

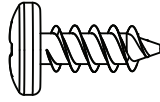

ADZ (x5)

11.6

- Slide the edge of the left hinge over right, front wall panel, align the holes, and secure with five (5) **screws (ADZ)**.
- Glissez le bord de la charnière gauche sur le panneau mural droit avant, alignez les trous, et attachez-le à l'aide de cinq (5) **vis (ADZ)**.
- Deslice el borde de la bisagra izquierda sobre el panel mural derecho delantero, alinee los agujeros, y sujételo usando cinco (5) **tornillos (ADZ)**.

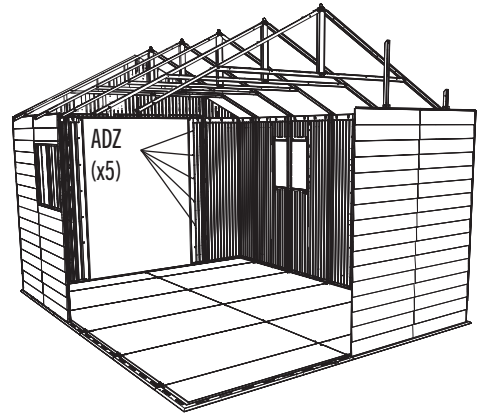
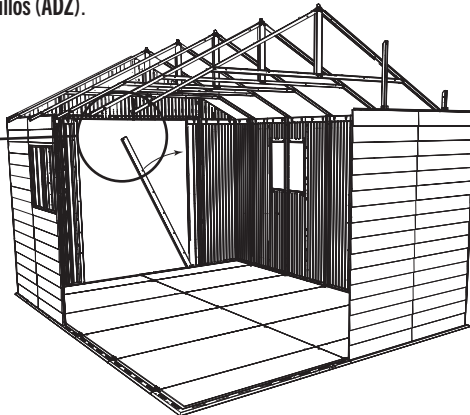
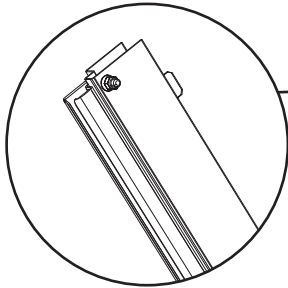

11.7

- Remove the nuts you tightened by hand in the previous steps from the top of the hinges. **Remove only the two nuts.**
- Soulevez les écrous que vous avez serrés à la main dans les étapes précédentes des extrémités supérieures des charnières. **Soulevez seulement les deux écrous.**
- Retire las tuercas que apretó a mano en los pasos anteriores de los extremos superiores de las bisagras. **Retire sólo las dos tuercas.**

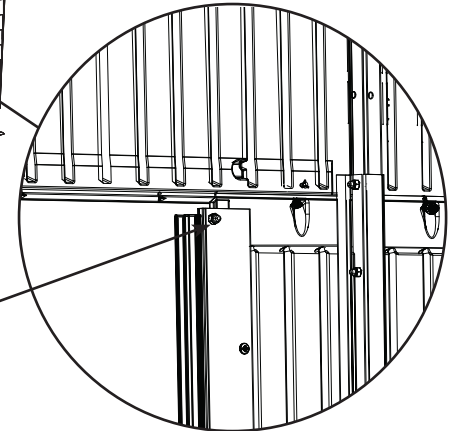
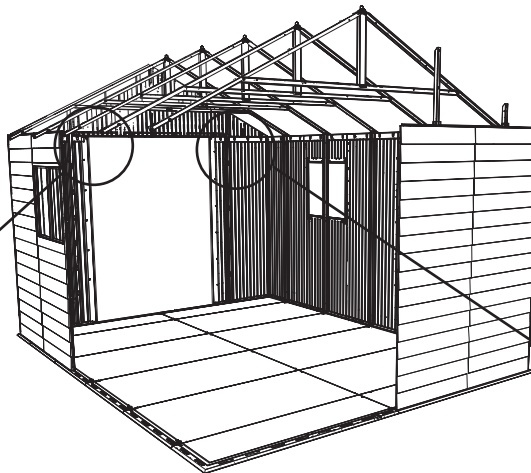
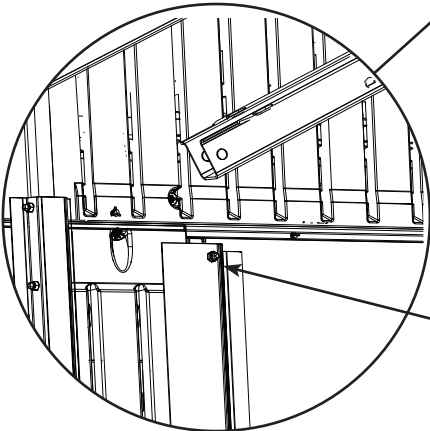

Nuts / Tuercas / Écrous

► SECTION 11 (CONTINUED) / SECTION 11 (SUITE) / SECCIÓN 11 (CONTINUACIÓN)

TOOLS AND HARDWARE REQUIRED / OUTILS ET QUINCAILLERIE REQUIS / INSTRUMENTAL Y HERRAJE REQUERIDOS



7/16 in/po (x2)
(≈11 mm)

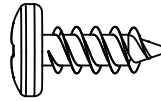

ADZ (x4)

11.8

- Place the **door header (AFD)** over the bolts and, with a wrench, retighten the nuts you removed in the previous step.
- Placez le **linteau (AFD)** sur les boulons et, à l'aide d'un clé, resserrez les écrous que vous avez enlevé dans l'étape précédente.
- Sujete el **dintel (AFD)** sobre los pernos y, avec una llave, reapriete las tuercas que retiró en el paso anterior.

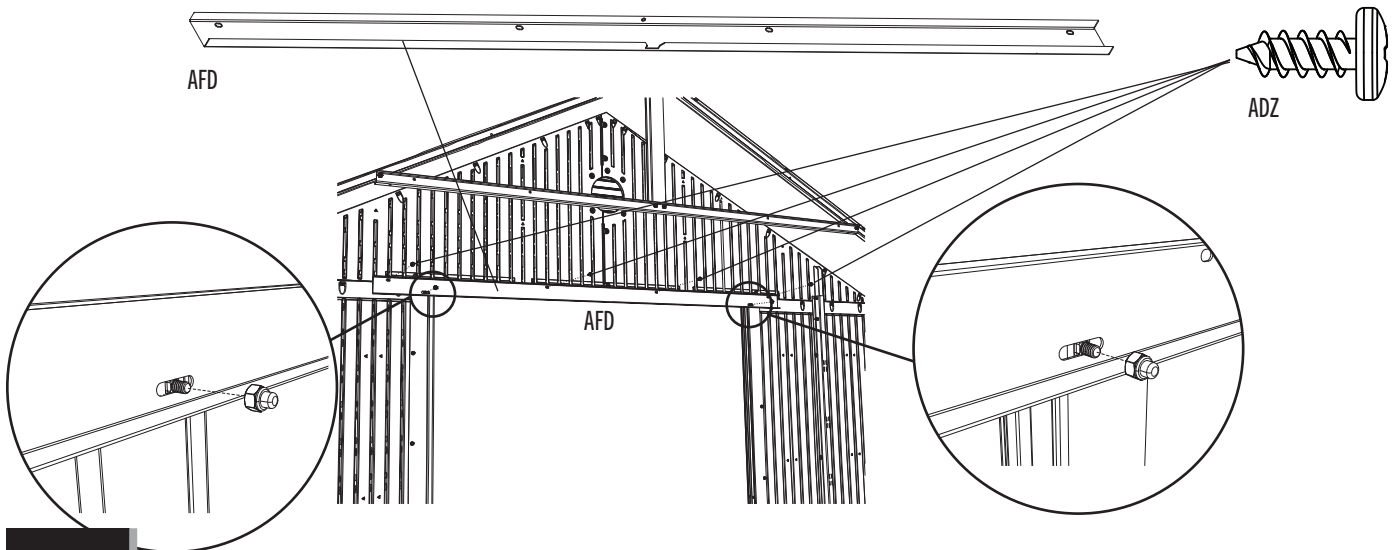

11.9

- Slide the left door down into the left hinge as shown.
- Glissez la porte gauche dans la charnière gauche comme illustré.
- Deslice la puerta izquierda dentro de la bisagra izquierda como se muestra.

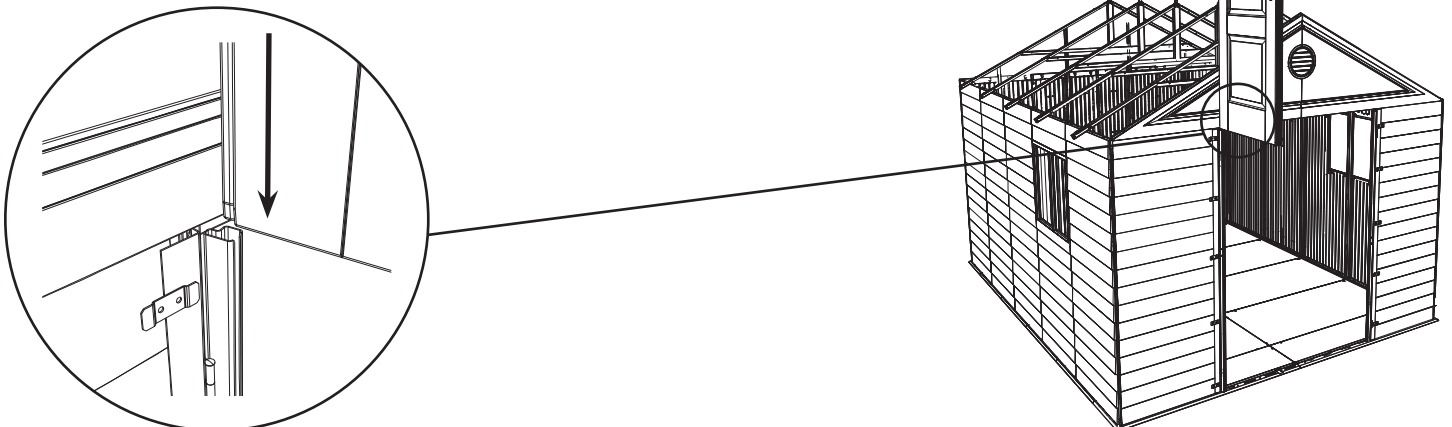

SECTION 11 (CONTINUED) / SECTION 11 (SUITE) / SECCIÓN 11 (CONTINUACIÓN)

TOOLS AND HARDWARE REQUIRED / OUTILS ET QUINCAILLERIE REQUIS / INSTRUMENTAL Y HERRAJE REQUERIDOS



7/16 in/po (x2)
(≈11 mm)

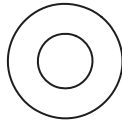

AEB (x4)



ADJ (x4)



AHL (x1)

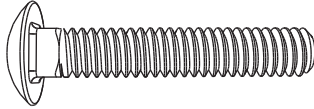

ACH (x4)



ADX (x2)

11.10

- Align the holes in the hinge with those in the left door. Secure the door to the hinge using the hardware provided.
- Aligner les trous dans la charnière avec ceux de la porte gauche. Attachez la porte à la charnière à l'aide de la quincaillerie incluse.
- Alinee los agujeros en la bisagra con ellos en la puerta izquierda. Sujete la puerta a la bisagra usando el herraje incluido.

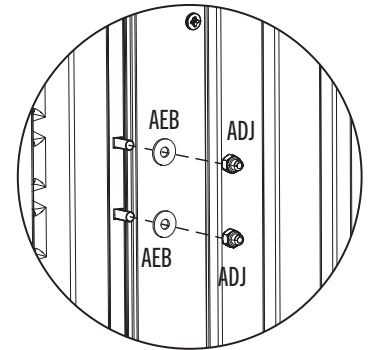
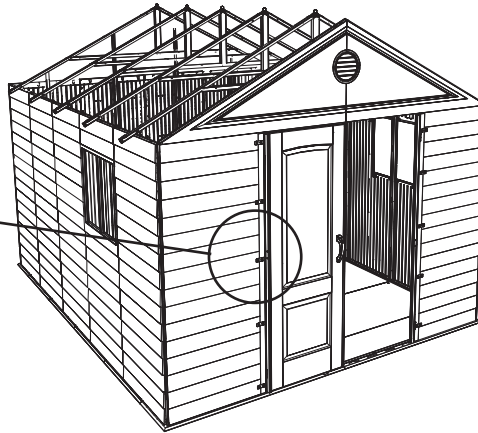
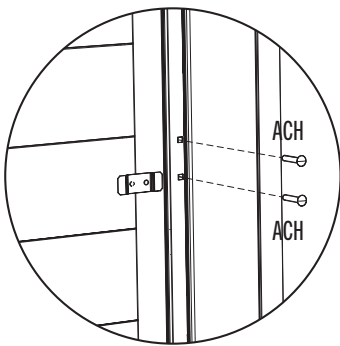

11.11

- Repeat steps 11.9–11.10 for the Right Door
- Répétez les étapes 11.9 – 11.10 pour la porte droite.
- Repita los pasos 11.9–11.10 para la puerta derecha.

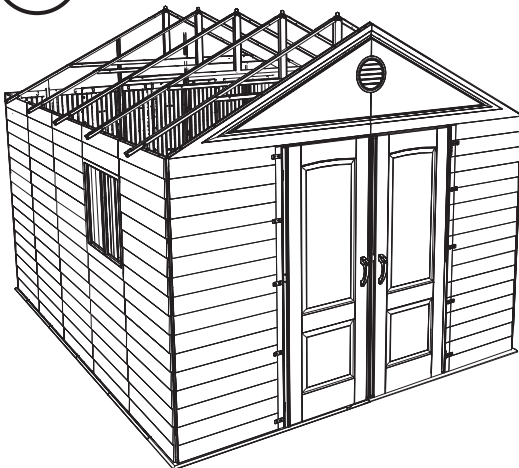

11.12

- Attach the **strike plate (AHL)** to the floor.
- Attachez la **gâche (AHL)** au plancher.
- Sujete la **placa de refuerzo (AHL)** al piso.

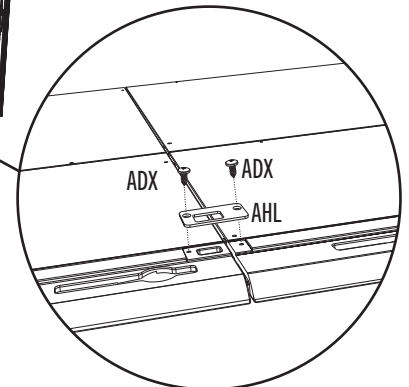
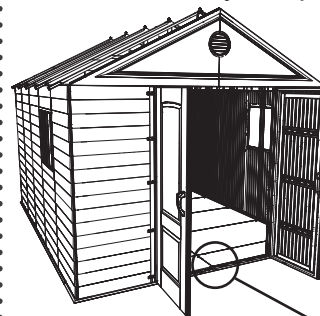



HARDWARE REQUIRED / QUINCAILLERIE REQUISE / HERRAJE REQUERIDO

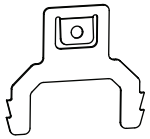
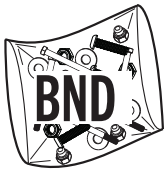

AHR (x2)

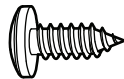

ADX (56)

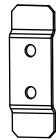

AHQ (x4)

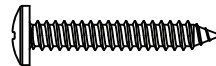

AYR (4)

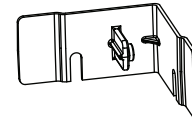

AGA (x24)



PARTS REQUIRED / PIÈCES REQUISES / PIEZAS REQUERIDAS

Plastic parts / Pièces en plastique / Piezas de plástico

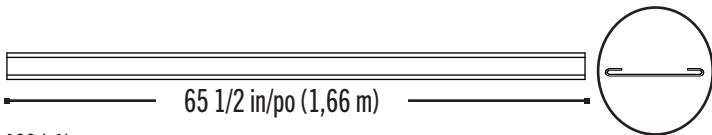

AGC (x1)

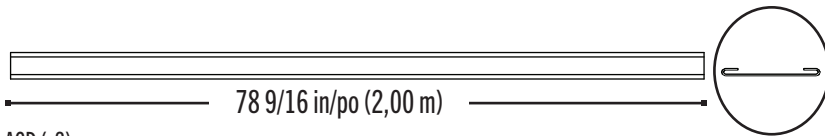

AGD (x2)

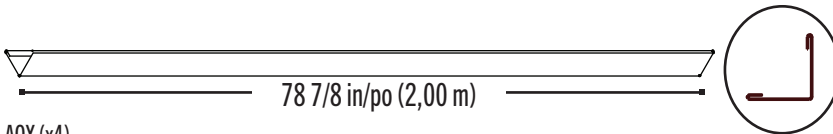

AQX (x4)



TOOLS REQUIRED / OUTILS REQUIS / INSTRUMENTAL REQUERIDO

(Not included—unless otherwise indicated*) / (Non inclus — sauf indication contraire*) / (No incluido, salvo indicación contraria*)

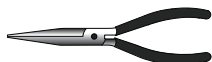

► SECTION 12 (CONTINUED) / SECTION 12 (SUITE) / SECCIÓN 12 (CONTINUACIÓN)

TOOLS AND HARDWARE REQUIRED / OUTILS ET QUINCAILLERIE REQUIS / INSTRUMENTAL Y HERRAJE REQUERIDOS

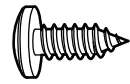
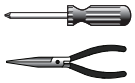

ADX (8)

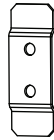

AHQ (x4)

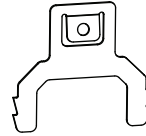

AHR (x2)

12.1

- Slide the two (2) pieces of **vertical trim (AGD)** down over the trim brackets.
- Glissez les deux (2) pièces de **moulures verticales (AGD)** sur les supports à moulure.
- Deslice las dos (2) piezas de **molduras verticales (AGD)** sobre los soportes de moldura.

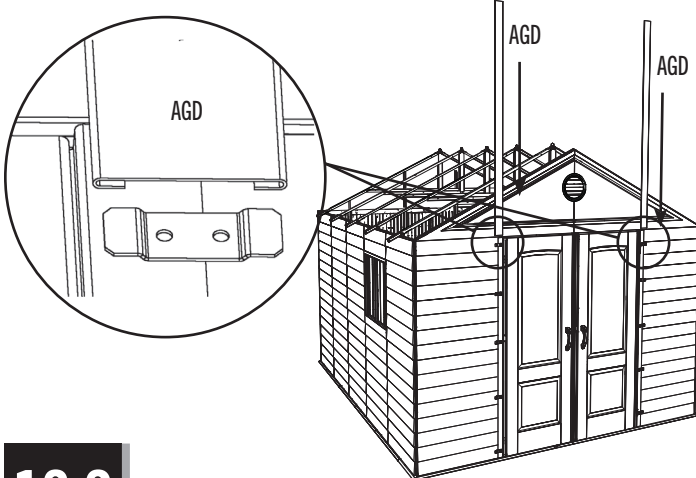

12.2

- Attach the four (4) **horizontal trim brackets (AHQ)** above the doors as shown.
- Attachez les quatre (4) **supports à moulure horizontale (AHQ)** sur les portes comme illustré.
- Sujete los cuatro (4) **soportes para la moldura horizontal (AHQ)** encima de las puertas como se muestra.

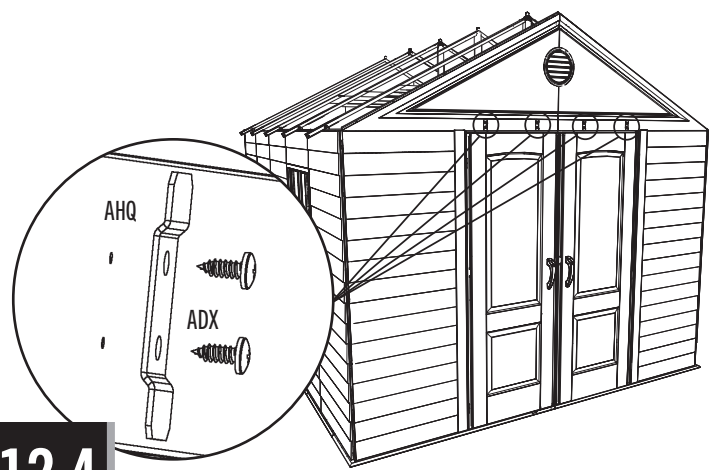

12.3

- Insert one (1) **trim clip (AHR)** into the top of each piece of vertical trim.
- Insérez un (1) **clip à moulure (AHR)** dedans l'extrémité supérieure de chaque pièce de moulure verticale.
- Inserte un (1) **clip para la moldura (AHR)** dentro del extremo superior de cada pieza de moldura vertical.

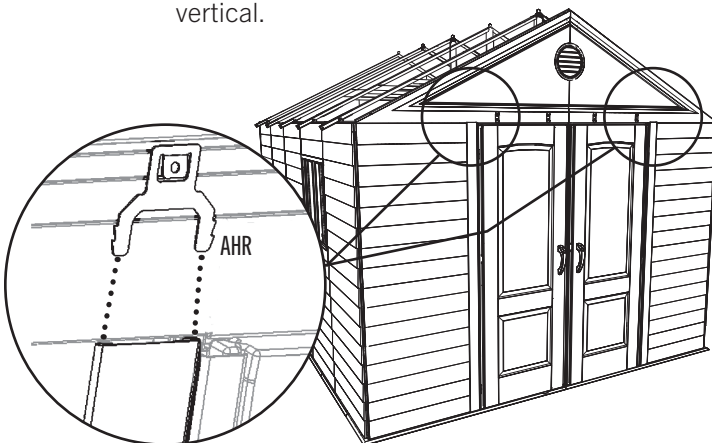

12.4

- Bend the tabs on the clips outward a bit. Slide the piece of **horizontal trim (AGC)** over the clips and brackets as shown.
- Plier les languettes des clips vers l'extérieur un peu. Faites glisser la pièce de **moulure horizontale (AGC)** sur les clips et les supports comme illustré.
- Tuerza las lengüetas en los clips hacia afuera un poco. Deslice la pieza de **moldura horizontal (AGC)** sobre los clips y los soportes como se muestra.

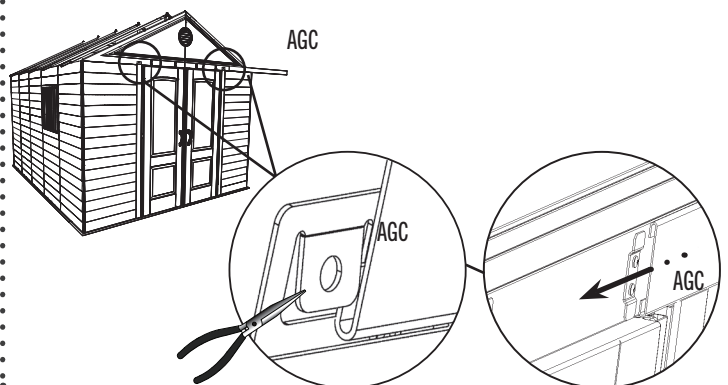

► SECTION 12 (CONTINUED) / SECTION 12 (SUITE) / SECCIÓN 12 (CONTINUACIÓN)

TOOLS AND HARDWARE REQUIRED / OUTILS ET QUINCAILLERIE REQUIS / INSTRUMENTAL Y HERRAJE REQUERIDOS

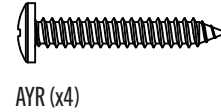
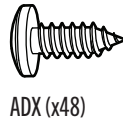
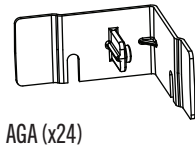

12.5

- Attach six (6) **corner brackets (AGA)** to each corner of the shed (24 in all) as shown.
- Attachez bien six (6) **supports angulaires (AGA)** a chaque coin de l'abri (24 en tout) comme illustré.
- Sujete seis (6) **supports angulares (AGA)** a cada esquina de la caseta (24 en total) como se muestra.

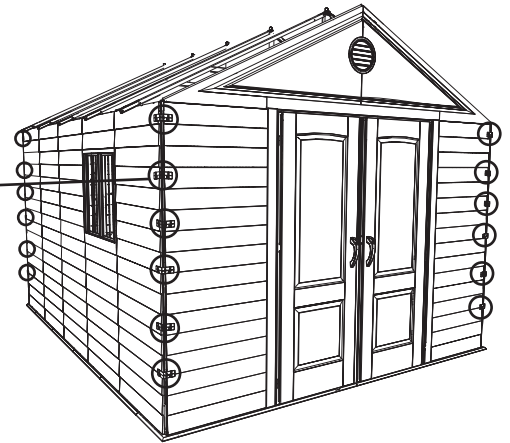
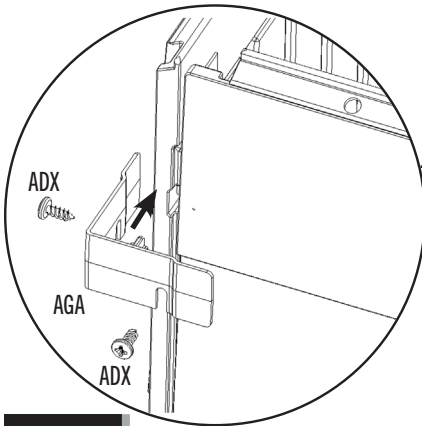

12.6

- Slide a piece of **corner trim (AQX)** down over the corner brackets of each corner as shown. Secure the trim at the top with one (1) **screw (AYR)**.
- Glissez une pièce de **moulure angulaire (AQX)** sur les supports angulaires de chaque coin comme illustré. Attachez le moulure à l'extrémité supérieure à l'aide d'une (1) **vis (AYR)**.
- Deslice una pieza de **moldura angular (AQX)** sobre los soportes angulares de cada esquina como se muestra. Sujete la moldura al extremo superior con un (1) **tornillo (AYR)**.

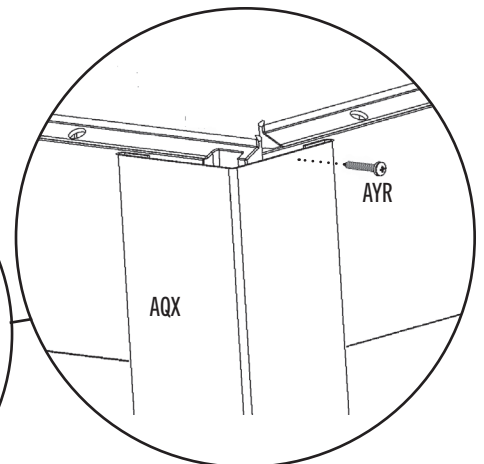
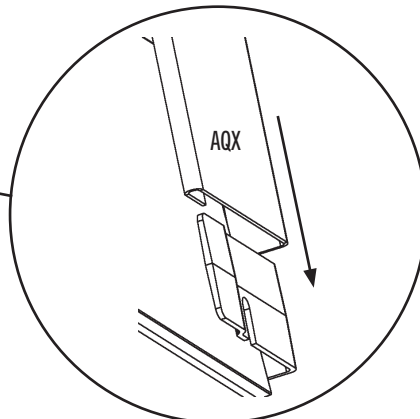
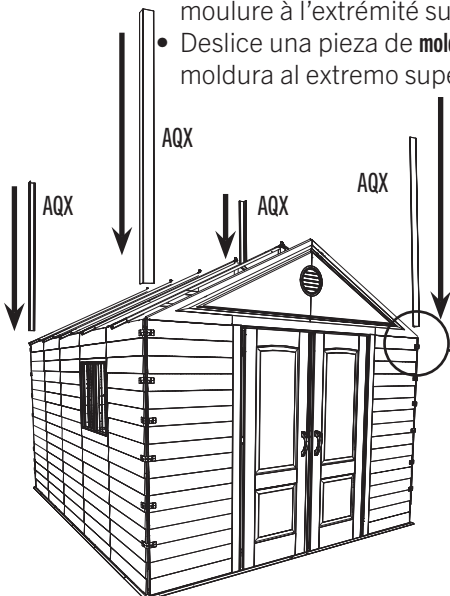



HARDWARE REQUIRED / QUINCAILLERIE REQUISE / HERRAJE REQUERIDO

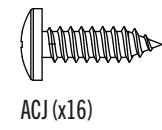

ACJ (x16)

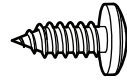

ADX (x4)



ACF (x1)



ADK (x1)

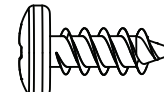

ADZ (x268)

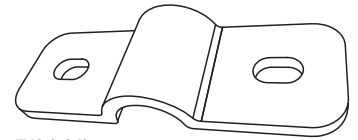

EVC (x24)

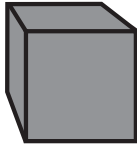

AJA (x20)

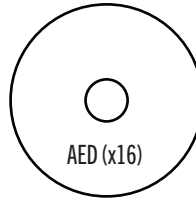

AED (x16)



PARTS REQUIRED / PIÈCES REQUISES / PIEZAS REQUERIDAS

Metal parts / Pièces en métal / Piezas de metal

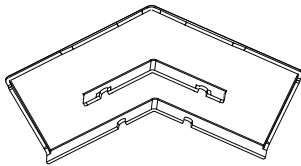

AHA (x2)

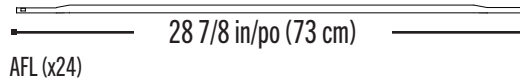

AFL (x24)

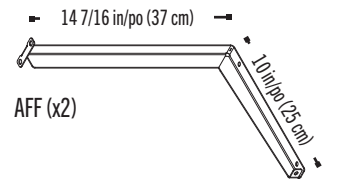

AFF (x2)

Plastic parts / Pièces en plastique / Piezas de plástico

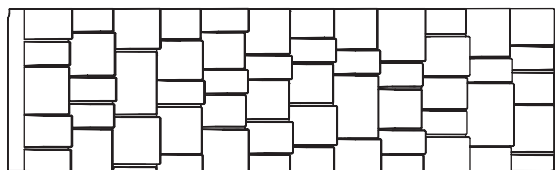

AGU (x2)

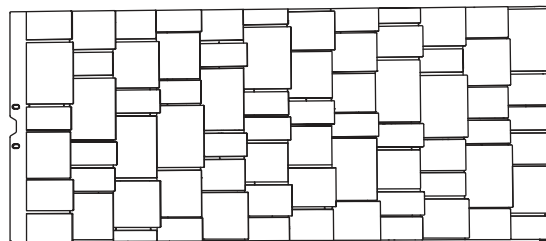

AGQ (x6)



AGE (x2)

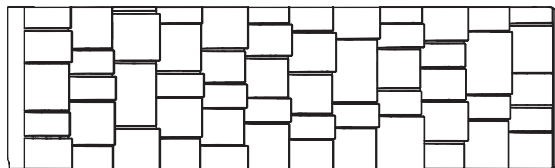

AGV (x2)

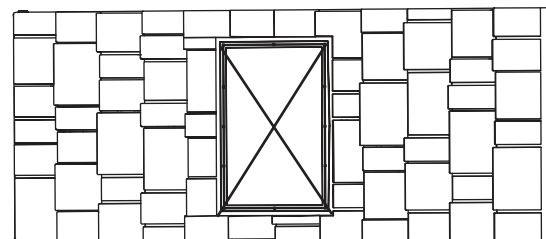

AHB (x2)

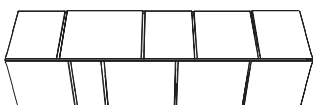

AFY (x4)



TOOLS REQUIRED / OUTILS REQUIS / INSTRUMENTAL REQUERIDO

(Not included—unless otherwise indicated*) / (Non inclus — sauf indication contraire*) / (No incluido, salvo indicación contratia*)



3/8 in/po (≈10 mm)

► SECTION 13 (CONTINUED) / SECTION 13 (SUITE) / SECCIÓN 13 (CONTINUACIÓN)

TOOLS AND HARDWARE REQUIRED / OUTILS ET QUINCAILLERIE REQUIS / INSTRUMENTAL Y HERRAJE REQUERIDOS

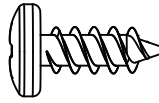

ADZ (x24)

13.1

- Set a **roof panel (AGU)** down onto the truss and front gable. Align the holes in the truss, gable, and wall panel with those in the roof panel. Secure the roof panel using twelve (12) **screws (ADZ)**.
- Mettez un **panneau de toit (AGU)** sur la ferme et le toit à pignon avant. Aligned les trous dans la ferme, le toit à pignon, et le panneau mural avec ceux dans le panneau de toit. Attachez le panneau de toit à l'aide de douze (12) **vis (ADZ)**.
- Coloque un **panel de tejado (AGU)** sobre la cercha y la fachada delantera. Alinee los agujeros en la cercha, la fachada, y el panel mural con ellos en el panel de tejado. Sujete el panel de tejado usando doce (12) **tornillos (ADZ)**.

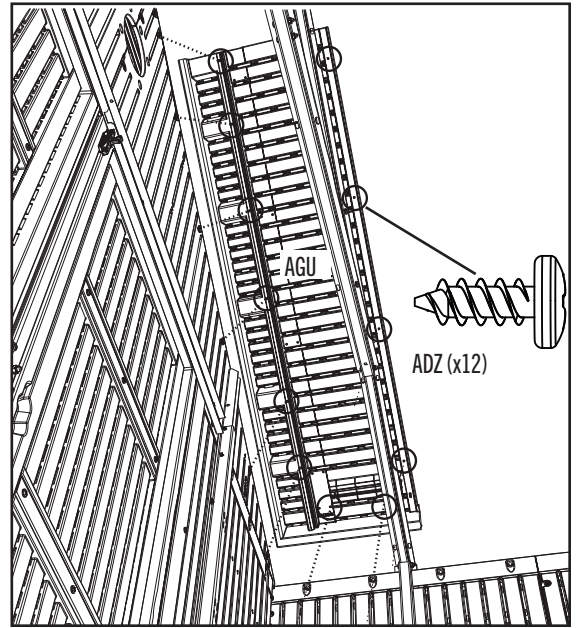
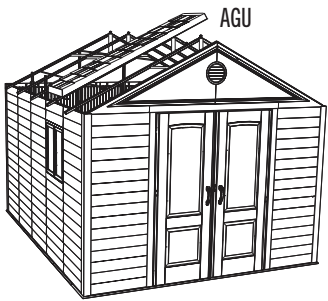

13.2



- Repeat this step for roof panel (AGV).
- Répétez cette étape pour un panneau de toit (AGV).
- Repita este paso para el panel de tejado (AGV).

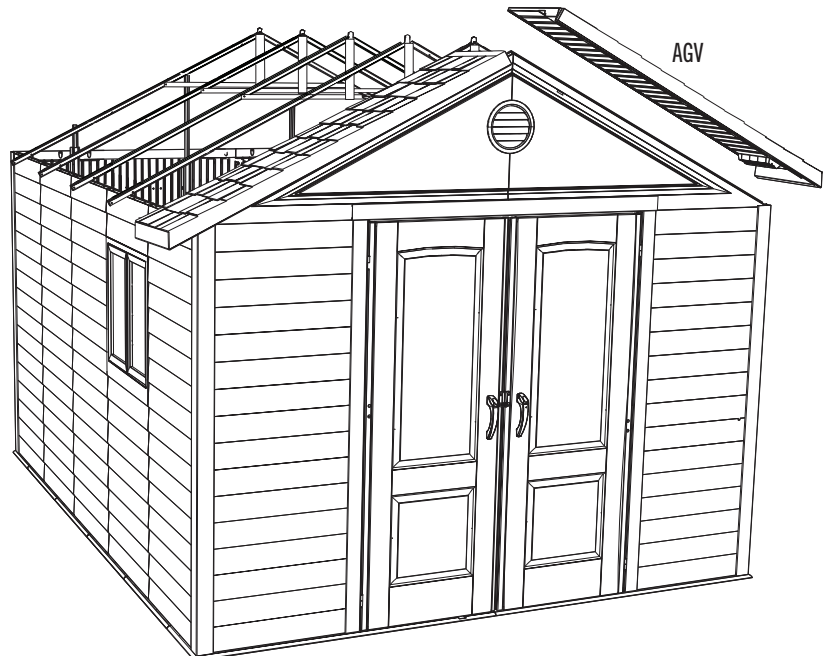

► SECTION 13 (CONTINUED) / SECTION 13 (SUITE) / SECCIÓN 13 (CONTINUACIÓN)

TOOLS AND HARDWARE REQUIRED / OUTILS ET QUINCAILLERIE REQUIS / INSTRUMENTAL Y HERRAJE REQUERIDOS

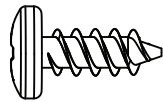

ADZ (x36)

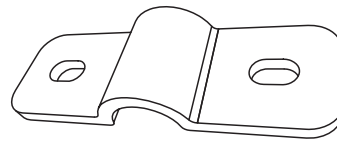

EVC (x6)

13.3

- Insert three (3) **roof supports (AFL)** into the notches in of the **roof panels (AGQ or AHB)** as you insert the screws into the panel.
- Insérez trois (3) **supports de toit (AFL)** dans les encoches dans les **panneaux de toit (AGQ ou AHB)** pendant que vous insérez les vis dans le panneau.
- Inserte tres (3) **soportes de tejado (AFL)** en las muescas en los **paneles de tejado (AGQ o AHB)** al insertar los tornillos en el panel.

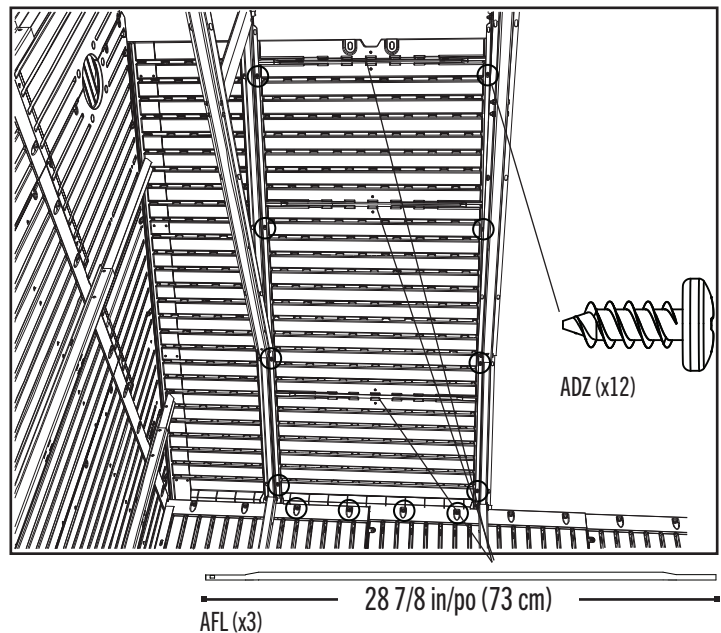
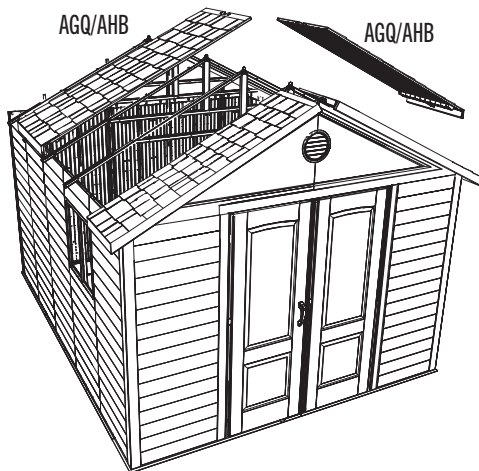

13.4



- Secure the roof supports to the roof panel using one (1) **support bracket (EVC)** for each roof support. **Repeat these steps for the other side of the roof.**
- Attachez bien les supports de toit aux panneaux de toit en utilisant un (1) **support (EVC)** par support de toit. **Répétez ces étapes pour l'autre côté du toit.**
- Sujete bien los soportes de tejado a los paneles de tejado usando un (1) **soporte (EVC)** por soporte de tejado. **Repita estos pasos para el otro lado del tejado.**

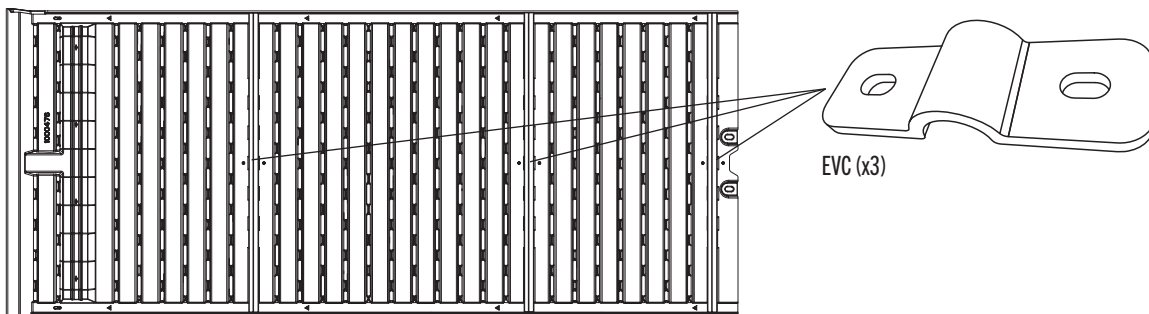

► SECTION 13 (CONTINUED) / SECTION 13 (SUITE) / SECCIÓN 13 (CONTINUACIÓN)

TOOLS AND HARDWARE REQUIRED / OUTILS ET QUINCAILLERIE REQUIS / INSTRUMENTAL Y HERRAJE REQUERIDOS

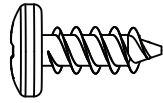

ADZ (x114)

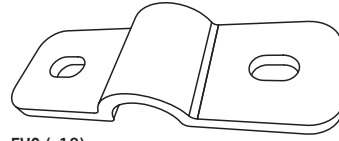

EVC (x18)

13.5

- Repeat the previous steps for the next six roof panels (AGQ or AHB). Install the supports (AFL) and support brackets (EVC) with them.
- Répétez les étapes précédentes pour les six panneaux de toit (AGQ ou AHB) suivantes. Installez les supports (AFL et EVC) avec ceux.
- Repita los pasos anteriores para los próximos seis paneles de tejado (AGQ o AHB). Instale los soportes (AFL y EVC) con ellos.



AFL (x18)

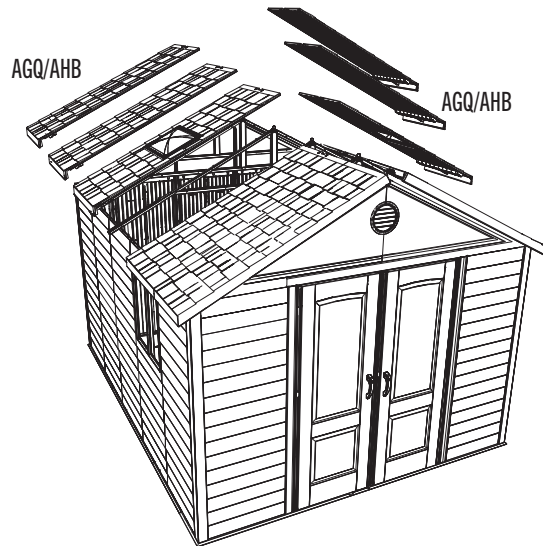

13.6

- Set a gable assembly onto the rear wall panels. Align the holes in the wall panels with those in the gable.
- Aligned les trous dans les panneaux muraux avec ceux dans le toit à pignon. Mettez l'ensemble de toit à pignon sur les panneaux muraux arrière.
- Alinee los agujeros en los paneles murales con ellos en la fachada. Coloque un conjunto de fachada en los paneles murales traseros.

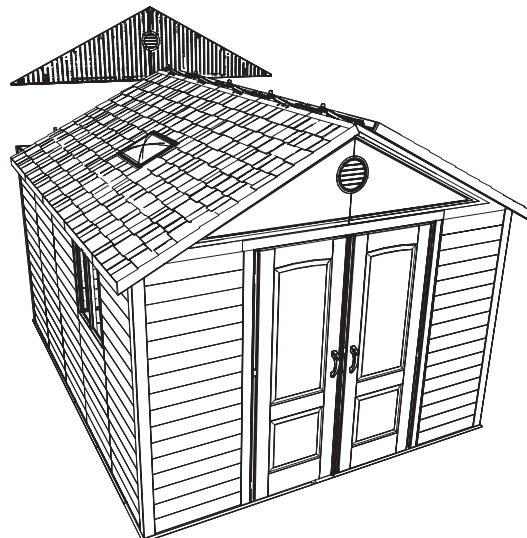

► SECTION 13 (CONTINUED) / SECTION 13 (SUITE) / SECCIÓN 13 (CONTINUACIÓN)

TOOLS AND HARDWARE REQUIRED / OUTILS ET QUINCAILLERIE REQUIS / INSTRUMENTAL Y HERRAJE REQUERIDOS

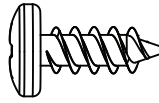

ADZ (x40)

13.7

- Secure the gable with sixteen (16) screws (ADZ). Secure the gable to the wall support channels using six (6) screws (ADZ).
- Attachez le toit à pignon à l'aide de seize (16) vis (ADZ). Attachez le toit à pignon aux supports muraux à l'aide de six (6) vis (ADZ).
- Sujete la fachada usando dieciséis (16) tornillos (ADZ). Sujete la fachada a los soportes murales usando seis (6) tornillos (ADZ).

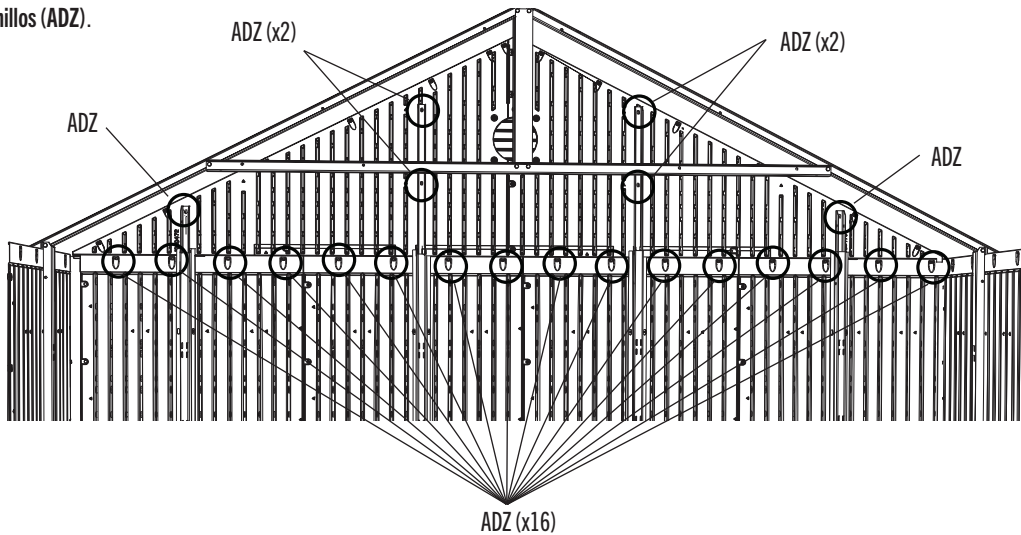

13.8

- Attach the last to outer roof panels (AGU & AGV) like the first two.
- Attachez les deux derniers panneaux de toit extérieurs (AGU et AGV) comme les premiers deux.
- Sujete los dos últimos paneles de tejado exteriores (AGU y AGV) como los primeros dos.

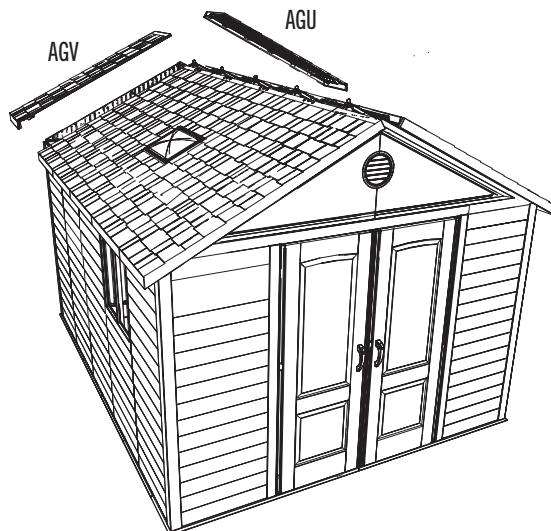

► SECTION 13 (CONTINUED) / SECTION 13 (SUITE) / SECCIÓN 13 (CONTINUACIÓN)

TOOLS AND HARDWARE REQUIRED / OUTILS ET QUINCAILLERIE REQUIS / INSTRUMENTAL Y HERRAJE REQUERIDOS

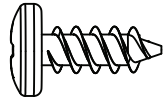

ADZ (x20)

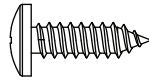

ACJ (x16)

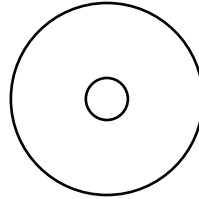

AED (x16)

13.9

- Starting at the front of the shed, attach the **roof caps (AGE & AFY)** using the hardware included.
- En commençant à la partie avant de l'abri, attachez les **capuchons de toit (AGE et AFY)** à l'aide de la quincaillerie incluse.
- Empezando a la parte delantera de la caseta, sujete las **cumbreras de tejado (AGE y AFY)** usando el herraje incluido.

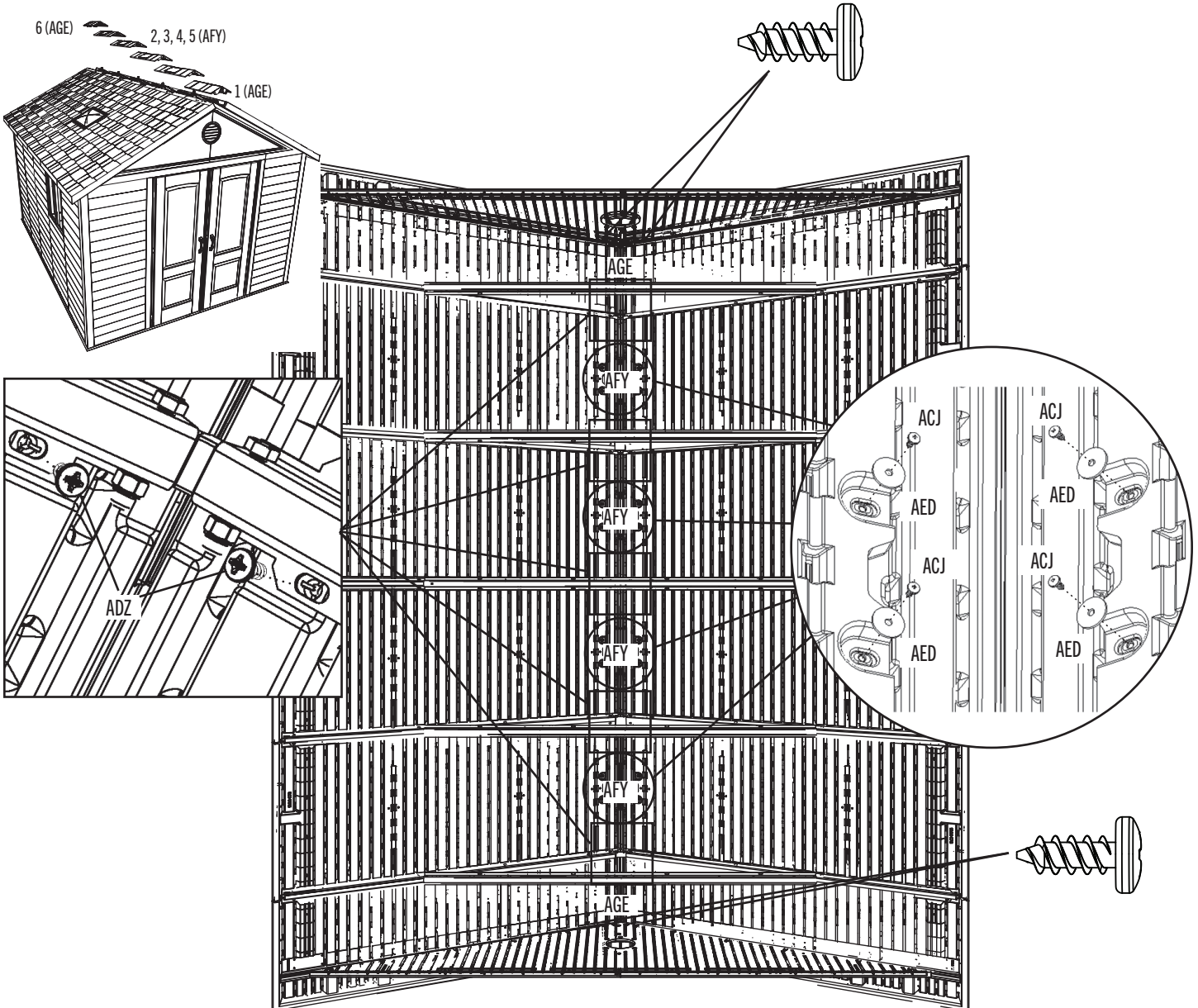

SECTION 13 (CONTINUED) / SECTION 13 (SUITE) / SECCIÓN 13 (CONTINUACIÓN)

TOOLS AND HARDWARE REQUIRED / OUTILS ET QUINCAILLERIE REQUIS / INSTRUMENTAL Y HERRAJE REQUERIDOS



7/16 in/po (x2)
(≈11 mm)

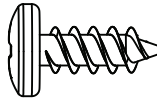

ADZ (x4)

13.10

- Attach the two (2) **roof end caps (AHA)** to the front and rear of the shed using two (2) **screws (ADZ)** each.
- Attachez les deux (2) **façades de toit (AHA)** aux parties avant et arrière de l'abri à l'aide de deux (2) **vis (ADZ)** chaque un.
- Sujete las dos (2) **fachadas de tejado (AHA)** a las partes delantera y trasera de la caseta usando dos (2) **tornillos (ADZ)** cada uno.

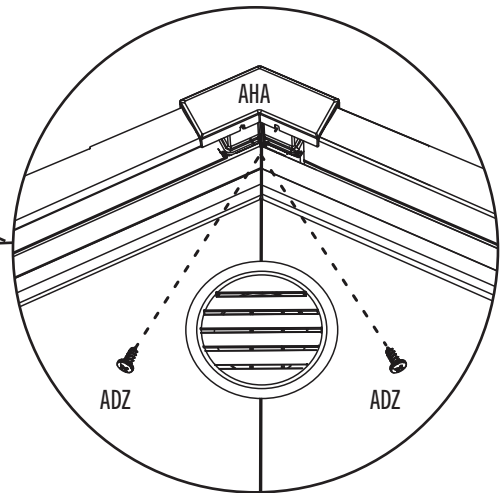
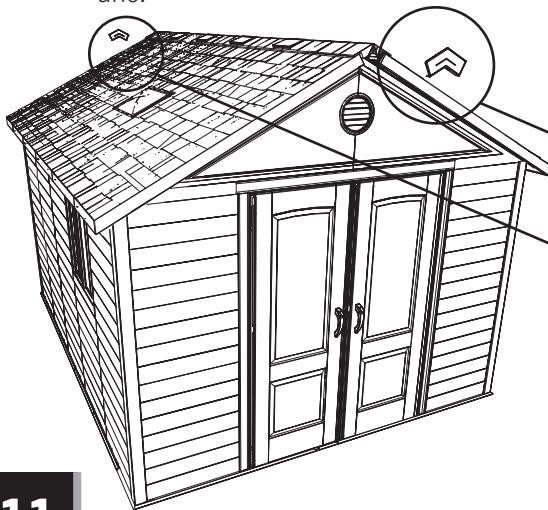

13.11

- Remove the Bolts and Nuts connecting the Horizontal Truss Brace to the Vertical Truss Brace.
- Soulevez les boulons et écrous qui attachent le support horizontal de la ferme aux supports verticaux de la ferme.
- Retire los pernos y tuercas que sujetan el soporte horizontal de la cercha a los soportes verticales de la cercha.

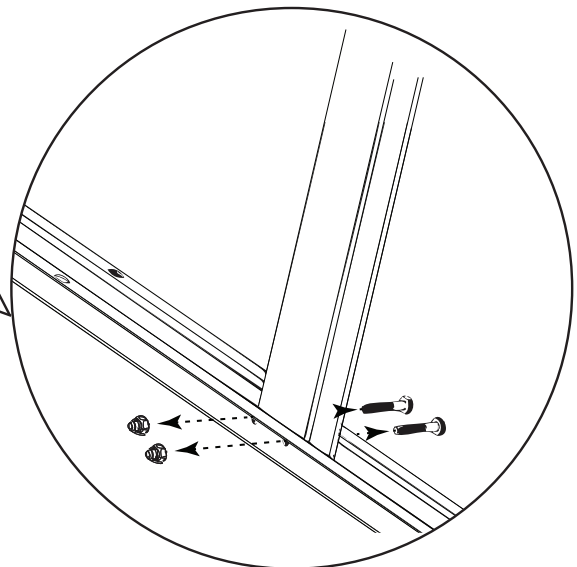
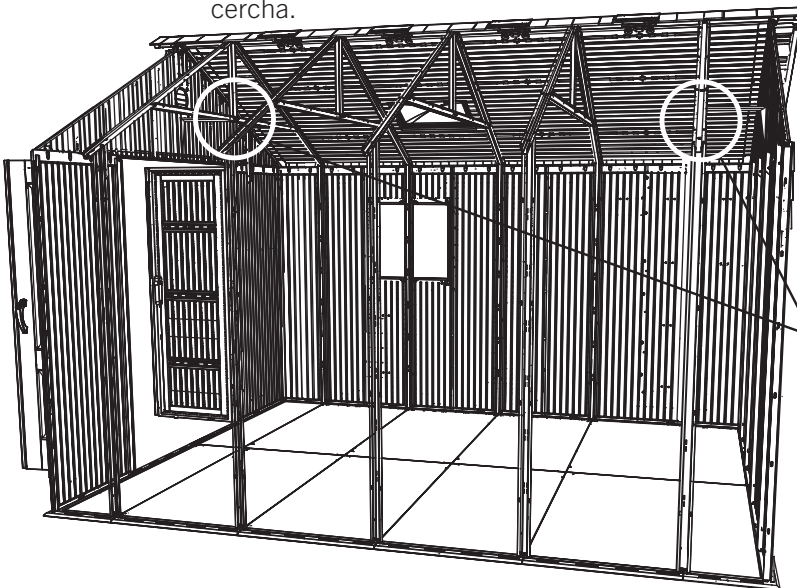

SECTION 13 (CONTINUED) / SECTION 13 (SUITE) / SECCIÓN 13 (CONTINUACIÓN)

TOOLS AND HARDWARE REQUIRED / OUTILS ET QUINCAILLERIE REQUIS / INSTRUMENTAL Y HERRAJE REQUERIDOS



7/16 in/po (x2)
(≈11 mm)



3/8 in/po
(≈10 mm)

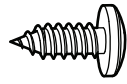

ADX (x4)



ADK (x2)



ACF (x2)

13.12

- Attach the **angle brackets (AFF)** to the truss as shown. Then, attach the brackets to the gables using two (2) **screws (ADX)** each. Finally, attach the bracket to the header using one (1) **screw (ACF)** and one (1) **cap nut (ADK)**.
- Attachez les **supports angulaires (AFF)** à la ferme comme illustré. Ensuite, attachez les supports aux toits à pignon à l'aide de deux (2) **vis (ADX)** chaque un. Enfin, attachez le support angulaire au linteau à l'aide d'un (1) **vis (ACF)** et d'un (1) **écrou à chape (ADK)**.
- Sujete los **soportes angulares (AFF)** a la cercha como se muestra. Entonces, sujete los soportes angulares a las fachadas usando dos (2) **tornillos (ADX)** cada uno. Por último, sujete el soporte al dintel usando un (1) **tornillo (ACF)** y una (1) **tuerca ciega (ADK)**.

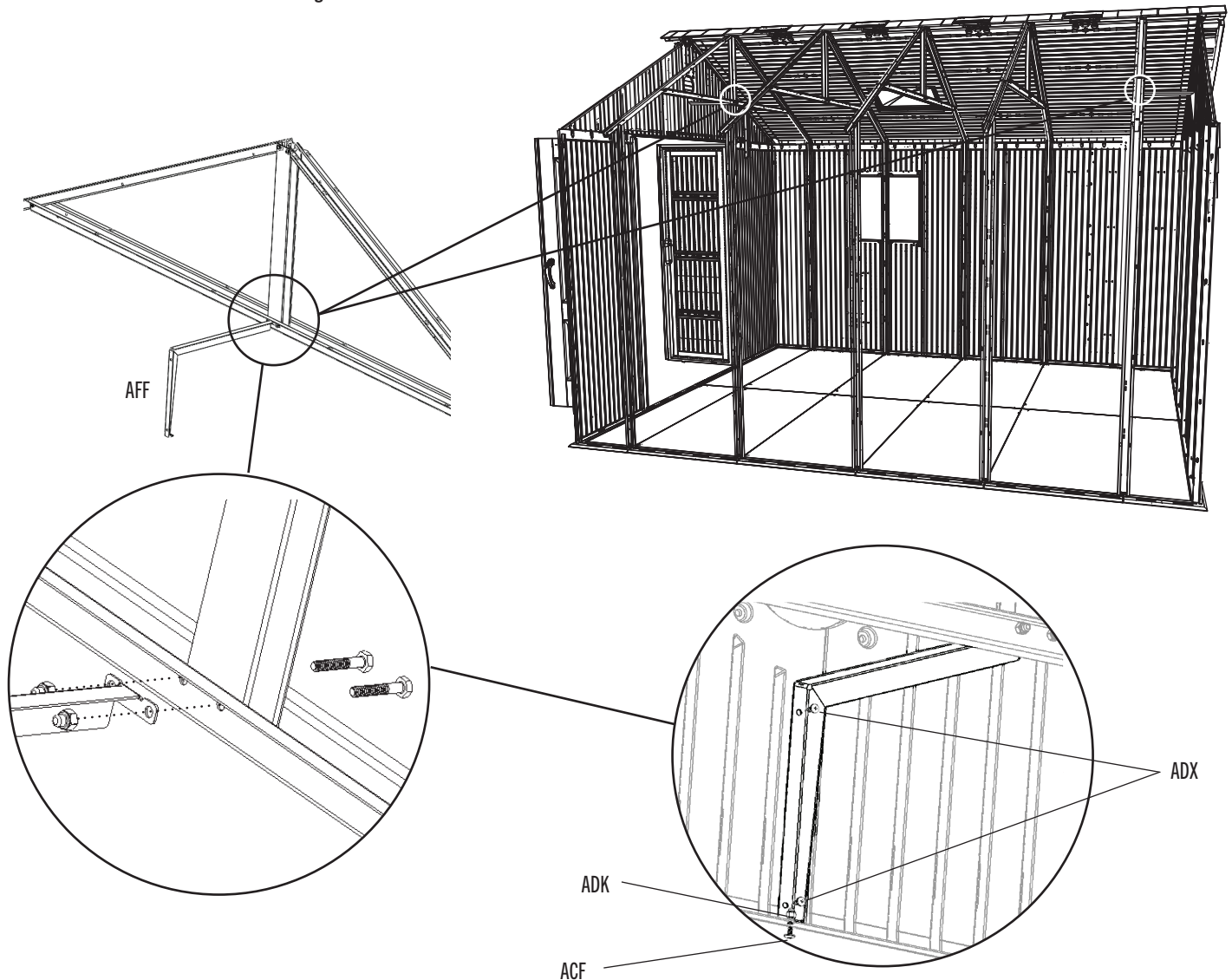

► SECTION 13 (CONTINUED) / SECTION 13 (SUITE) / SECCIÓN 13 (CONTINUACIÓN)

TOOLS AND HARDWARE REQUIRED / OUTILS ET QUINCAILLERIE REQUIS / INSTRUMENTAL Y HERRAJE REQUERIDOS

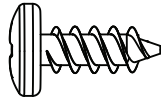

ADZ (x20)

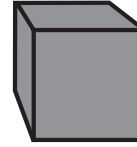

AJA (x20)

13.13

- Insert two (2) **screws (ADZ)** through each truss and into the roof panels.
- Insérez deux (2) **vis (ADZ)** à travers la ferme et dedans les panneaux de toit.
- Inserte dos (2) **tornillos (ADZ)** a través de la cercha y dentro de los paneles de tejado.

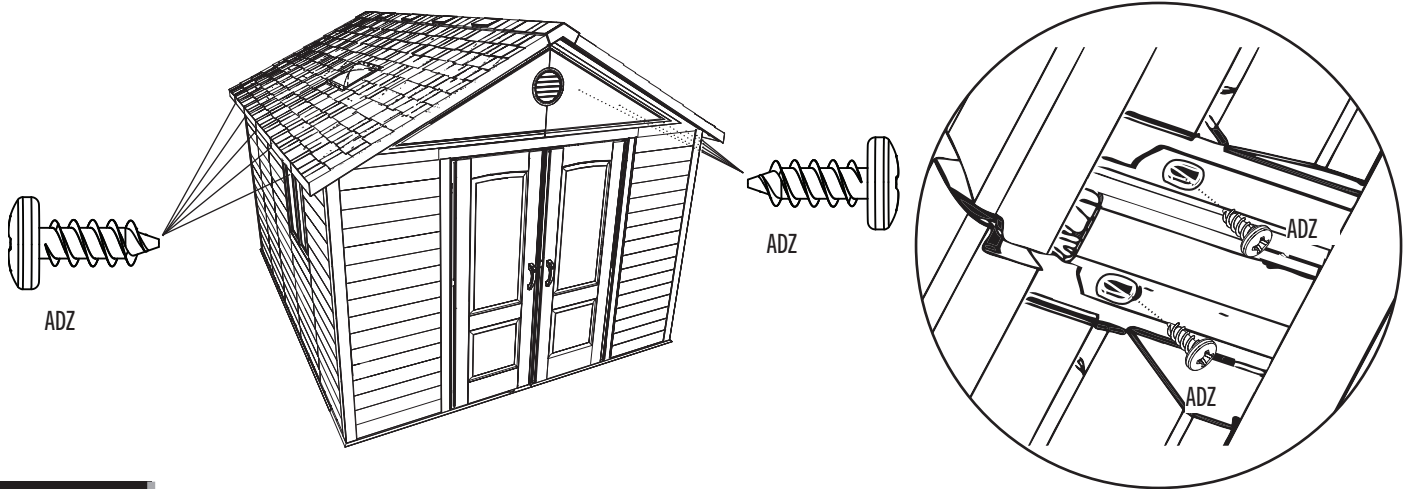

13.14

- Insert a **foam block (AJA)** into the spaces between the trusses and the wall panels.
- Insérez un **cube en mousse (AJA)** dans les espaces entre les fermes et les panneaux muraux.
- Inserte un **cubo de espuma (AJA)** en los espacios entre las cerchas y los paneles murales.

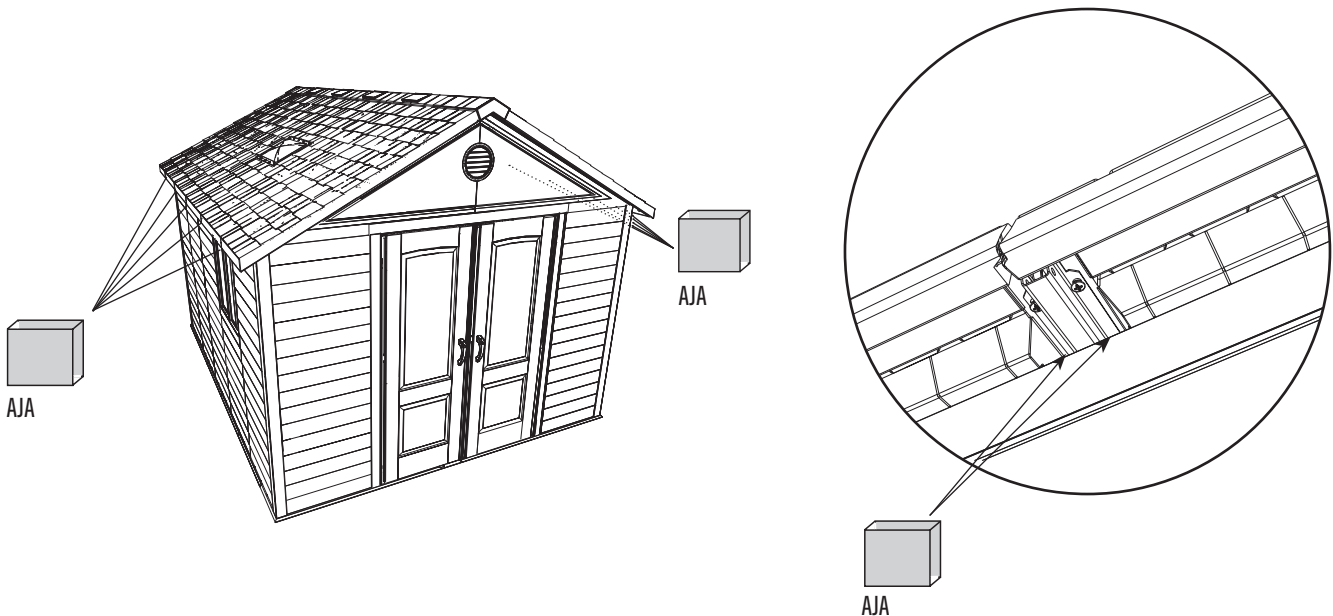



HARDWARE REQUIRED / QUINCAILLERIE REQUISE / HERRAJE REQUERIDO

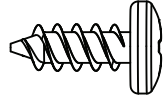

ADZ (x8)

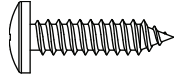

ADW (x8)

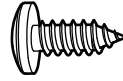

ADX (x44)

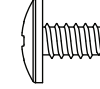

ACF (x4)

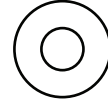

AEE (x4)

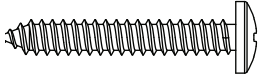

ACB (x8)

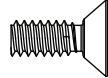

ACD (x4)



ADK (x4)

Parts / Pièces / Piezas



AIN (x4)

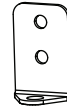

AIV (x4)

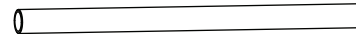

AIR (x8)

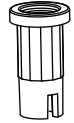

AIU (x8)

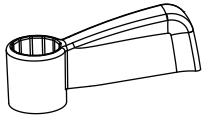

AIT (x8)

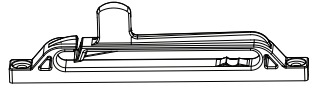

AIE (x4)



PARTS REQUIRED / PIÈCES REQUISES / PIEZAS REQUERIDAS

Plastic parts / Pièces en plastique / Piezas de plástico

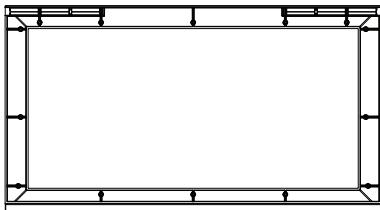

AHG (x4)

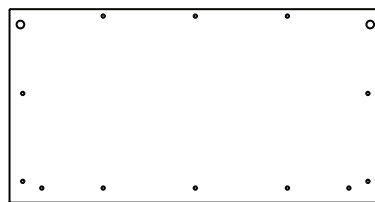

AHF (x4)



TOOLS REQUIRED / OUTILS REQUIS / INSTRUMENTAL REQUERIDO



3/8 in/po (≈10 mm)

► SECTION 14 (CONTINUED) / SECTION 14 (SUITE) / SECCIÓN 14 (CONTINUACIÓN)

TOOLS AND HARDWARE REQUIRED / OUTILS ET QUINCAILLERIE REQUIS / INSTRUMENTAL Y HERRAJE REQUERIDOS

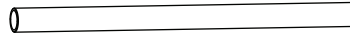

AIR (x8)

14.1

- Insert each **hinge tube (AIR)** up into the holes at the corners of each window as shown.
- Insérez chaque **tube de charnière (AIR)** dans les trous aux coins de chaque fenêtre comme illustré.
- Introduzca cada **tubo de bisagra (AIR)** dentro de los agujeros en las esquinas de cada ventana como se muestra.

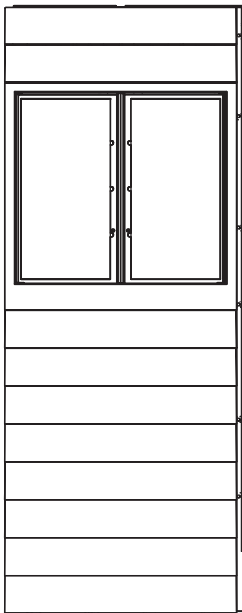

Holes / Agujeros / Trous

Holes / Agujeros / Trous

14.2

- Peel off the protective backing from both sides of the **window pane (AHF)**. Repeat this step for the second window pane.
- Soulevez la pellicule protectrice des deux côtés de la **carreau (AHF)**. Répétez cette étape pour la deuxième carreau.
- Retire la capa protectora de las dos caras de la **hoja de ventana (AHF)**. Repita este paso para la segunda hoja.

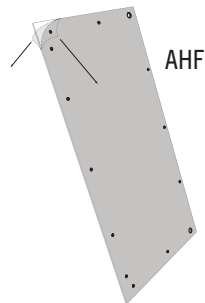

14.3

- Repeat this step for the second set of window panes.
- Répétez cette étape pour le deuxième jeu de carreaux.
- Repita este paso para el segundo juego de hojas.

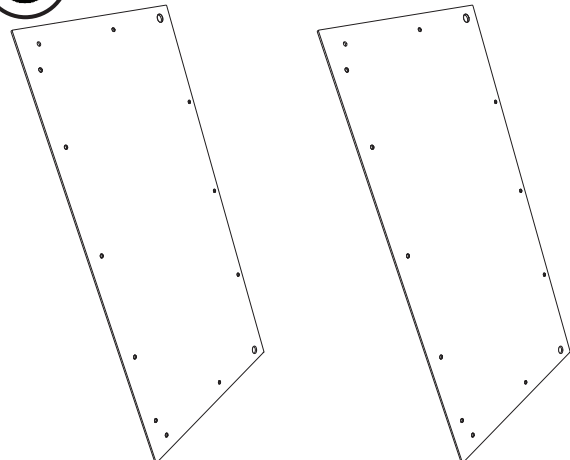

► SECTION 14 (CONTINUED) / SECTION 14 (SUITE) / SECCIÓN 14 (CONTINUACIÓN)

TOOLS AND HARDWARE REQUIRED / OUTILS ET QUINCAILLERIE REQUIS / INSTRUMENTAL Y HERRAJE REQUERIDOS



14.4

- Place a **window frame (AHG)** over a set of hinge tubes as shown.
- Mettez un **cadre de fenêtre (AHG)** sur un jeu de charnières comme illustré.
- Coloque un **marco de ventana (AHG)** sobre un juego de bisagras como se muestra.

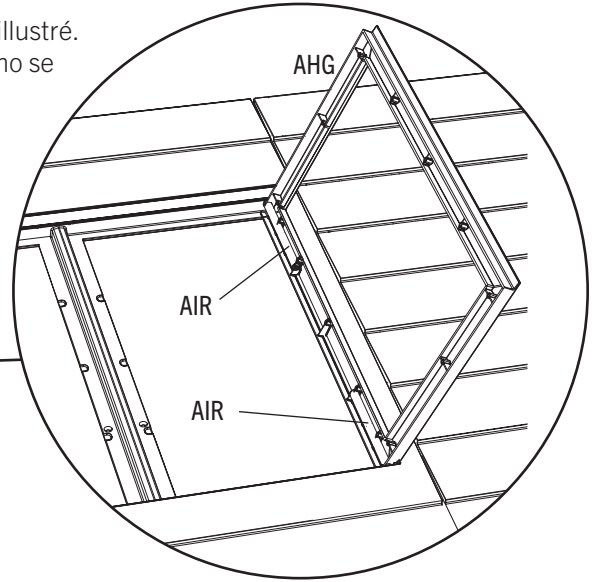
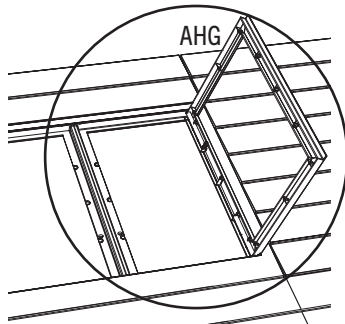
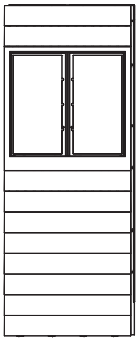

14.5

- Repeat the last step for the second frame.
- Répétez l'étape précédente pour le deuxième fenêtre.
- Repita el paso anterior para el segundo marco.

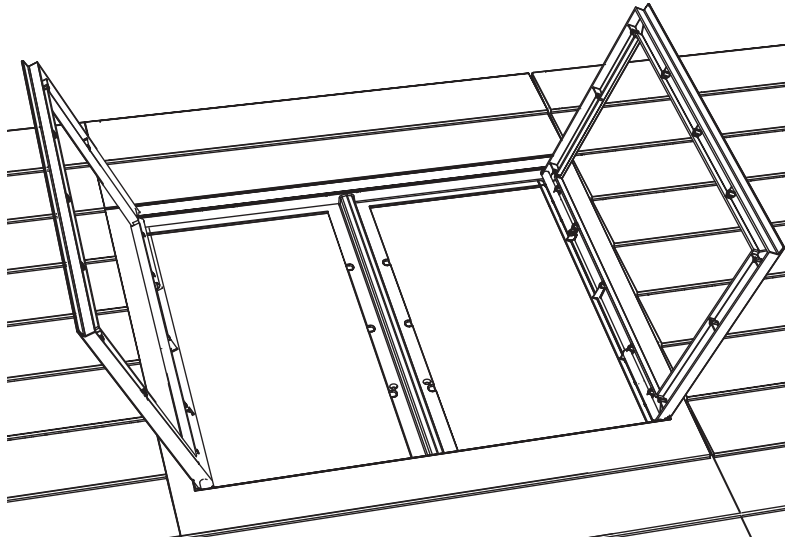

► SECTION 14 (CONTINUED) / SECTION 14 (SUITE) / SECCIÓN 14 (CONTINUACIÓN)

TOOLS AND HARDWARE REQUIRED / OUTILS ET QUINCAILLERIE REQUIS / INSTRUMENTAL Y HERRAJE REQUERIDOS

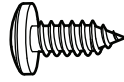

ADX (x40)

14.6

- Attach the window panes to the frames only at the locations indicated.
- Attachez les carreaux aux cadres seulement aux endroits indiqués.
- Sujete las hojas a los marcos sólo a las ubicaciones indicadas.

Window panes / Carreaux / Hojas de ventana

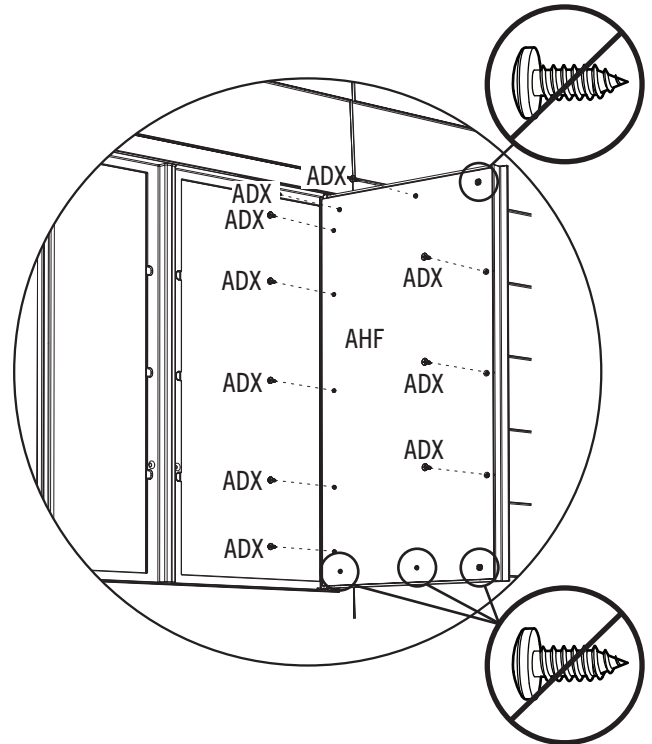
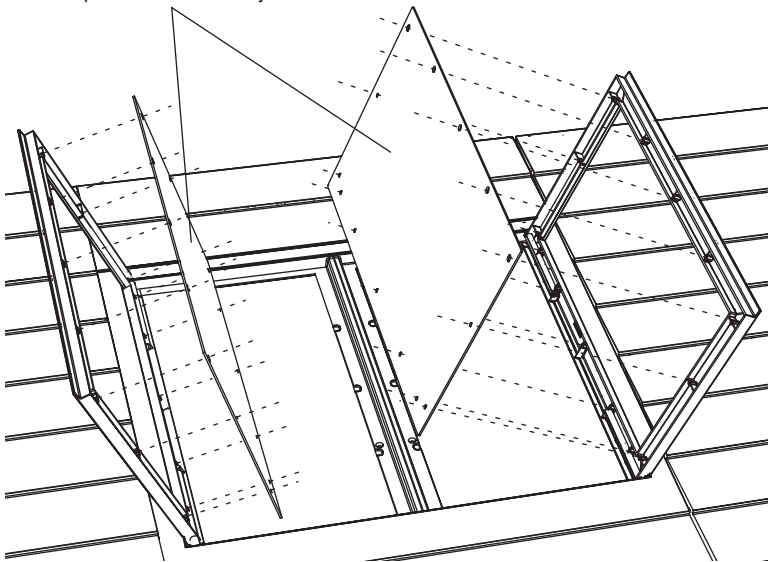

► SECTION 14 (CONTINUED) / SECTION 14 (SUITE) / SECCIÓN 14 (CONTINUACIÓN)

TOOLS AND HARDWARE REQUIRED / OUTILS ET QUINCAILLERIE REQUIS / INSTRUMENTAL Y HERRAJE REQUERIDOS

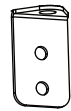

AIV (x4)

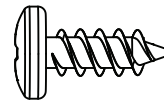

ADZ (x8)

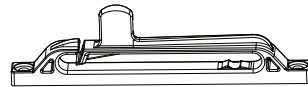

AIE (x4)

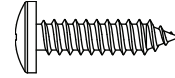

ADW (x8)

14.7

- Attach a **window stay bracket (AIV)** to each side of a window wall panel as shown.
- Attachez un **support à limiteur d'ouverture de fenêtre (AIV)** à chaque côté d'un panneau mural à fenêtre comme illustré.
- Sujete un **sopORTE para el limitador de apertura para la ventana (AIV)** a cada lado de un panel mural para la ventana como se muestra.

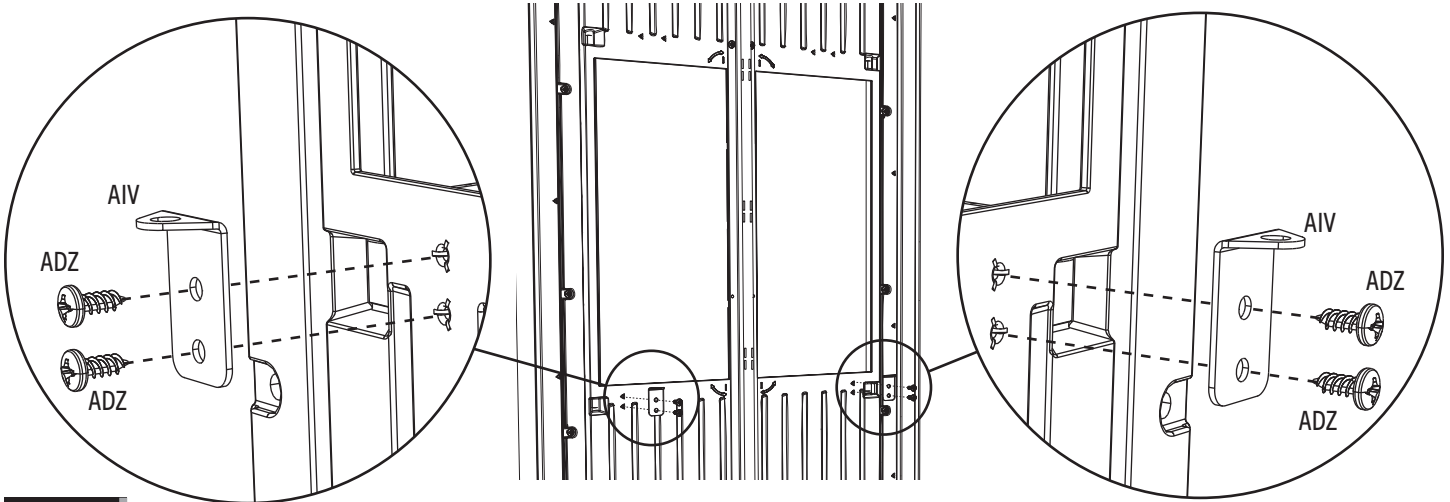

14.8

- Attach the **window stays (AIE)** to the window frames at the locations shown.
- Attachez les **limiteur d'ouverture de fenêtre (AIE)** aux cadres de fenêtre aux endroits indiqués.
- Sujete los **limitadores de apertura para la ventana (AIE)** a los marcos de ventana a las ubicaciones indicadas.

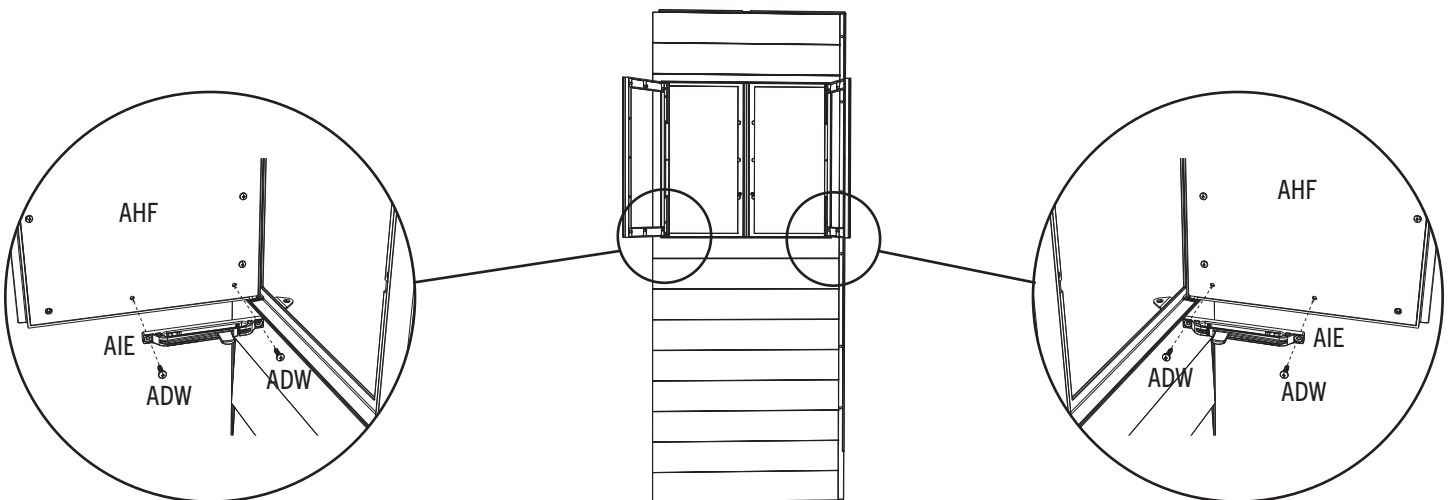

► SECTION 14 (CONTINUED) / SECTION 14 (SUITE) / SECCIÓN 14 (CONTINUACIÓN)

TOOLS AND HARDWARE REQUIRED / OUTILS ET QUINCAILLERIE REQUIS / INSTRUMENTAL Y HERRAJE REQUERIDOS



AIN (x4)



ACF (x4)

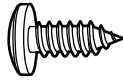

ADX (x4)

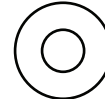

AEE (x4)

14.9

- Insert a screw (ADX) into each sliding window stay (AIN) as shown.
- Insérez une vis (ADX) dans chaque limiteur d'ouverture glissant de fenêtre (AIN) comme illustré.
- Inserte un tornillo (ADX) en cada limitador corredizo de apertura para la ventana (AIN) como se muestra.

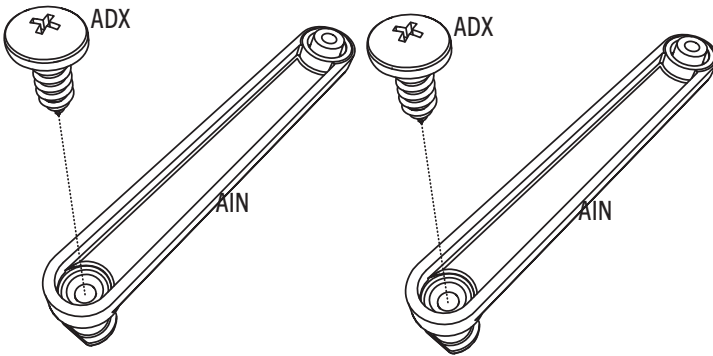

14.10

- Insert the sliding window stay into window stay as shown. **Repeat this step for a second window stay.**
- Insérez un limiteur d'ouverture glissant de fenêtre dans un limiteur d'ouverture de fenêtre comme illustré. **Répétez cette étape pour un deuxième limiteur d'ouverture de fenêtre.**
- Inserte un limitador corredizo de apertura para la ventana en un limitador de apertura para la ventana como se muestra. **Repita este paso para un segundo limitador de apertura para la ventana.**

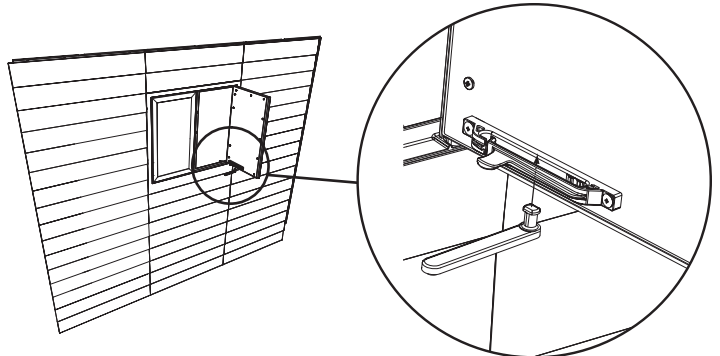

14.11

- Attach the sliding window stays to the sliding window stay brackets as shown.
- Attachez le limiteur d'ouverture glissant de fenêtre au support au limiteur d'ouverture de fenêtre comme illustré.
- Sujete el limitador corredizo de apertura para la ventana al soporte del limitador corredizo de apertura para la ventana como se muestra.

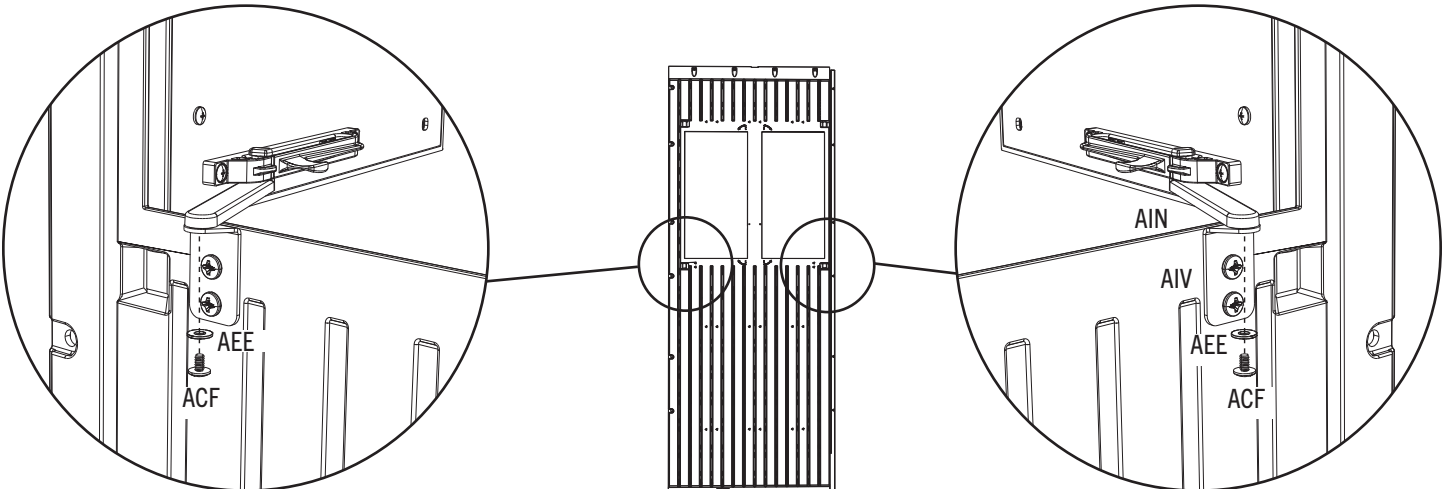

SECTION 14 (CONTINUED) / SECTION 14 (SUITE) / SECCIÓN 14 (CONTINUACIÓN)

TOOLS AND HARDWARE REQUIRED / OUTILS ET QUINCAILLERIE REQUIS / INSTRUMENTAL Y HERRAJE REQUERIDOS



3/8 in/po
(≈10 mm)

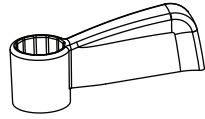

AIT (x8)

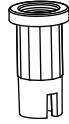

AIU (x8)

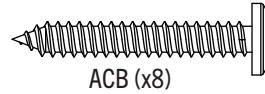

ACB (x8)

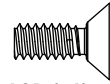

ACD (x4)



ADK (x4)

14.12

- Attach two **window latches (AIT)** to each window frame as shown.
- Attachez deux **loquets de fenêtres (AIT)** à chaque cadre de fenêtre comme illustré.
- Sujete dos **pestillo de ventana (AIT)** a cada marco de ventana como se muestra.

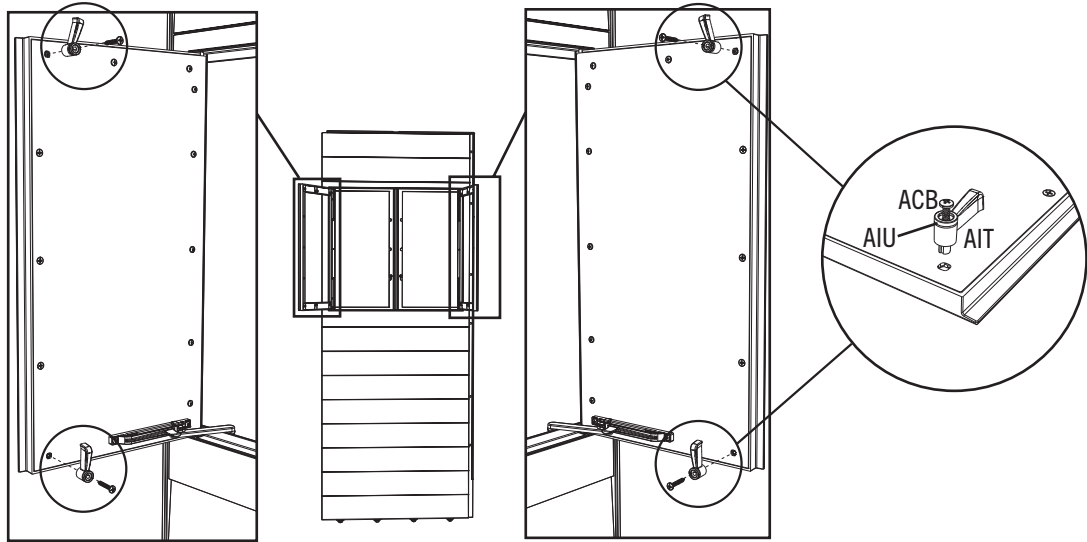

14.13

- Insert two **screws (ACD)** through the two window wall panels and wall support channels. Secure each with a **cap nut (ADK)** as shown. **Do not overtighten the nuts.**
- Insérez deux **vis (ACD)** à travers les deux panneaux muraux à fenêtre et les canaux de support muraux. Attachez chaque vis à l'aide d'un **écrou à chape (ADK)** comme illustré. **Ne pas trop serrer les écrous.**
- Inserte dos **tornillos (ACD)** a través de los dos paneles murales para la ventana y los canales de soporte murales. Sujete cada tornillo con una **tuerca ciega (ADK)** como se muestra. **No apriete demasiado las tuercas.**

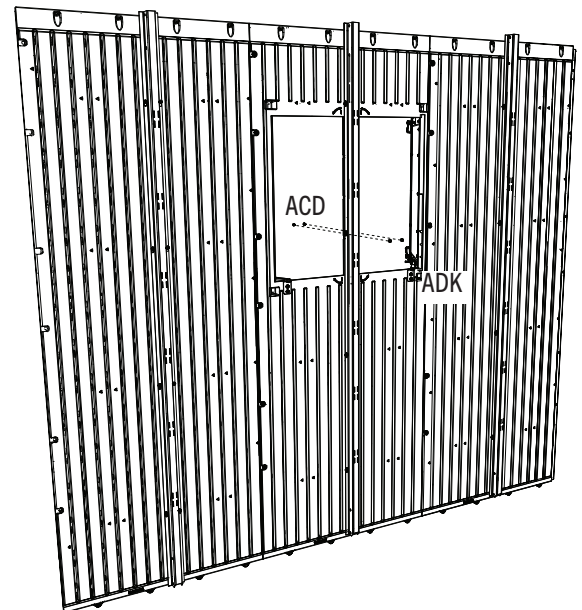



HARDWARE REQUIRED / QUINCAILLERIE REQUISE / HERRAJE REQUERIDO

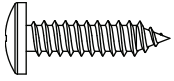

ADW (x10)

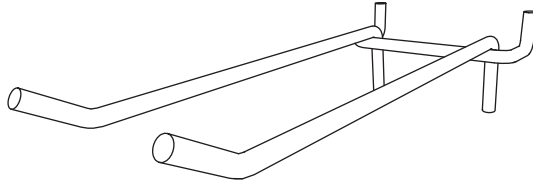

AIG (x1)

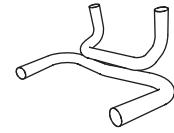

AIJ (x2)

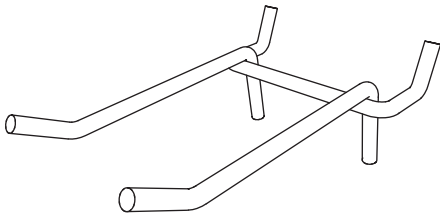

AIF (x1)

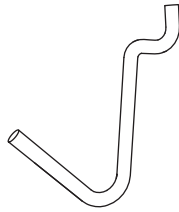

AIH (x3)

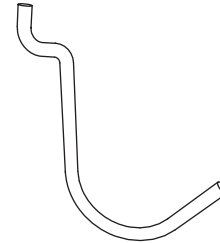

AII (x3)



PARTS REQUIRED / PIÈCES REQUISES / PIEZAS REQUERIDAS

Plastic parts / Pièces en plastique / Piezas de plástico

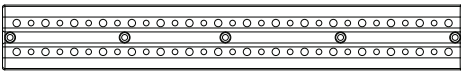

AFU (x2)



TOOLS REQUIRED / OUTILS REQUIS / INSTRUMENTAL REQUERIDO

(Not included—unless otherwise indicated*) / (Non inclus — sauf indication contraire*) / (No incluido, salvo indicación contratia*)



► SECTION 15 (CONTINUED) / SECTION 15 (SUITE) / SECCIÓN 15 (CONTINUACIÓN)

TOOLS AND HARDWARE REQUIRED / OUTILS ET QUINCAILLERIE REQUIS / INSTRUMENTAL Y HERRAJE REQUERIDOS

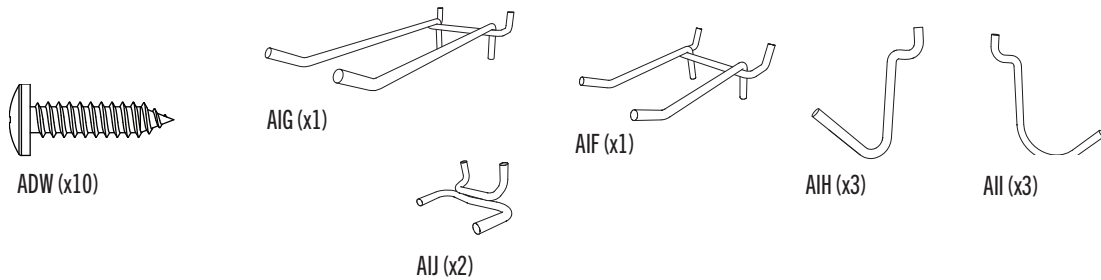

15.1

- Attach the **pegboard strips (AFU)** to the wall panels using five (5) screws (**ADW**) for each. **Try to avoid placing the holes in the strip over grooves in the Wall Panels. They may be attached to the side wall panels also.**
- Attachez les **organiseurs d'outils (AFU)** aux panneaux muraux à l'aide de cinq (5) vis (**ADW**) chaque un. **Essayez d'éviter situer les trous dans l'organisateur sur les rainures dans les panneaux muraux. Vous pouvez les attacher également aux panneaux muraux latéraux.**
- Sujete los **organizadores de herramientas (AFU)** a los paneles de pared usando cinco (5) tornillos (**ADW**) cada uno. **Trate de evitar de situar los agujeros en el organizador encima de las ranuras en los paneles murales. Se los pueden sujetar también a los paneles murales laterales.**

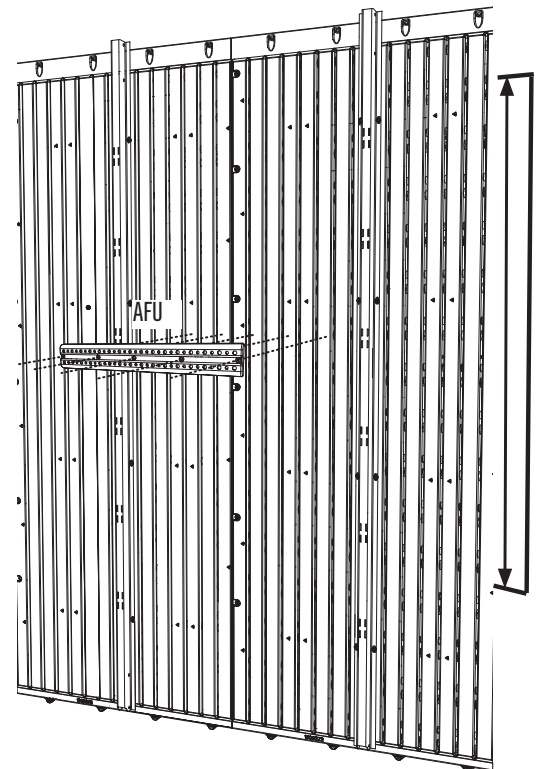

15.2

- Insert the various **hooks (AIF, AIG, AIH, AII, AIJ)** as shown. **Repeat this section for the second pegboard strip.**
- Insérez les divers **crochets (AIF, AIG, AIH, AII, AIJ)** comme illustré. **Répétez cette section pour le deuxième organisateur d'outils.**
- Inserte los varios **canchos (AIF, AIG, AIH, AII, AIJ)** como se muestra. **Repita esta sección para el segundo organizador de herramientas.**

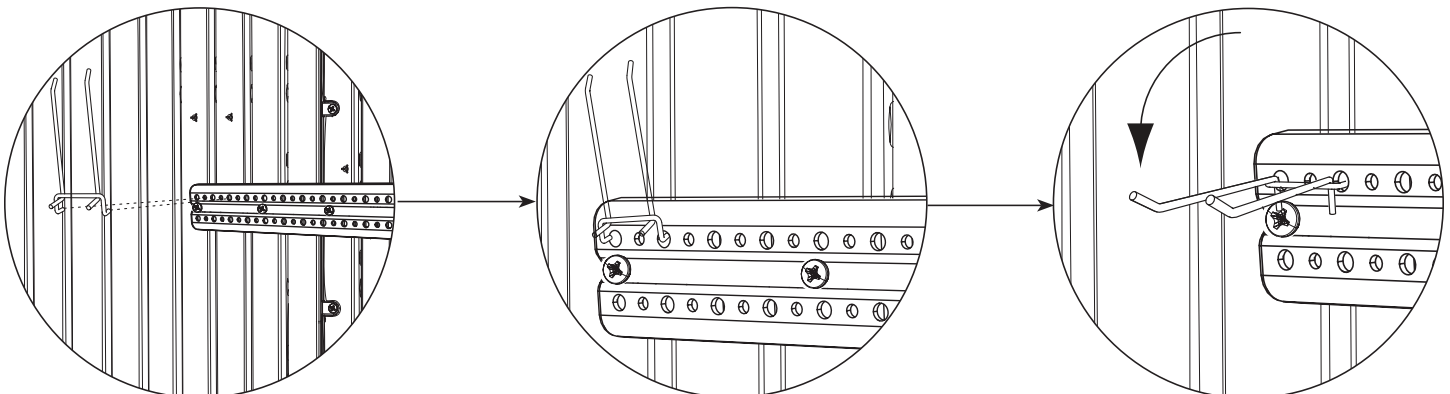

16

DOOR ALIGNMENT / ALIGNEMENT DES PORTES / ALINEACIÓN DE LAS PUERTAS



HARDWARE REQUIRED / QUINCAILLERIE REQUISE / HERRAJE REQUERIDO



PARTS REQUIRED / PIÈCES REQUISES / PIEZAS REQUERIDAS



TOOLS REQUIRED / OUTILS REQUIS / INSTRUMENTAL REQUERIDO

(Not included—unless otherwise indicated) / (Non inclus — sauf indication contraire*) / (No incluido, salvo indicación contratia*)*

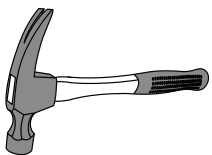

7/16 in/po
(≈11 mm)

► SECTION 16 (CONTINUED) / SECTION 16 (SUITE) / SECCIÓN 16 (CONTINUACIÓN)

TOOLS AND PARTS REQUIRED / OUTILS ET PIÈCES REQUIS / INSTRUMENTAL Y HERRAJE REQUERIDOS



7/16 in/po
(≈11 mm)



16.1

- If the doors are not parallel with one another, do the following:
- Si les portes ne sont pas parallèles l'une avec l'autre, faites les étapes suivantes :
- Si las puertas no están paralelas la una con la otra, haga lo siguiente:

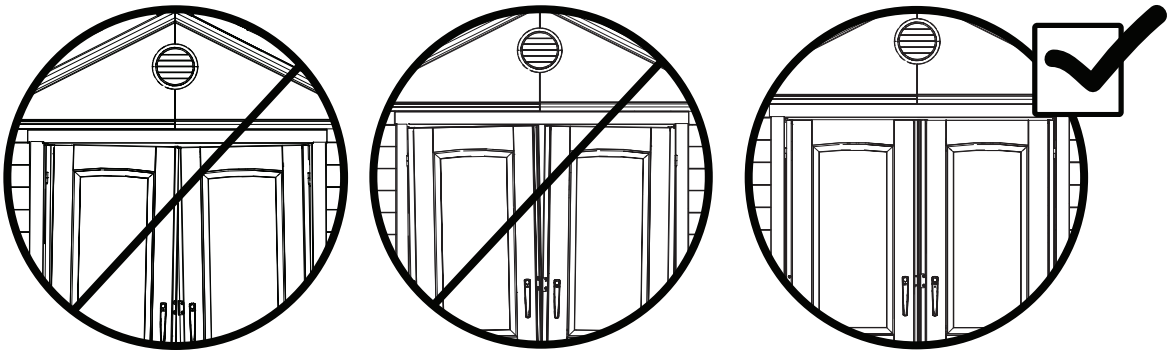

16.2

- Loosen the two cap nuts on the door header above the hinges a 1/2 turn.
- Afloje las dos tuercas ciegas en el dintel encima de las bisagras una media vuelta.
- Deserrez les deux écrous à chape sur le linteau au-dessus des charnières.

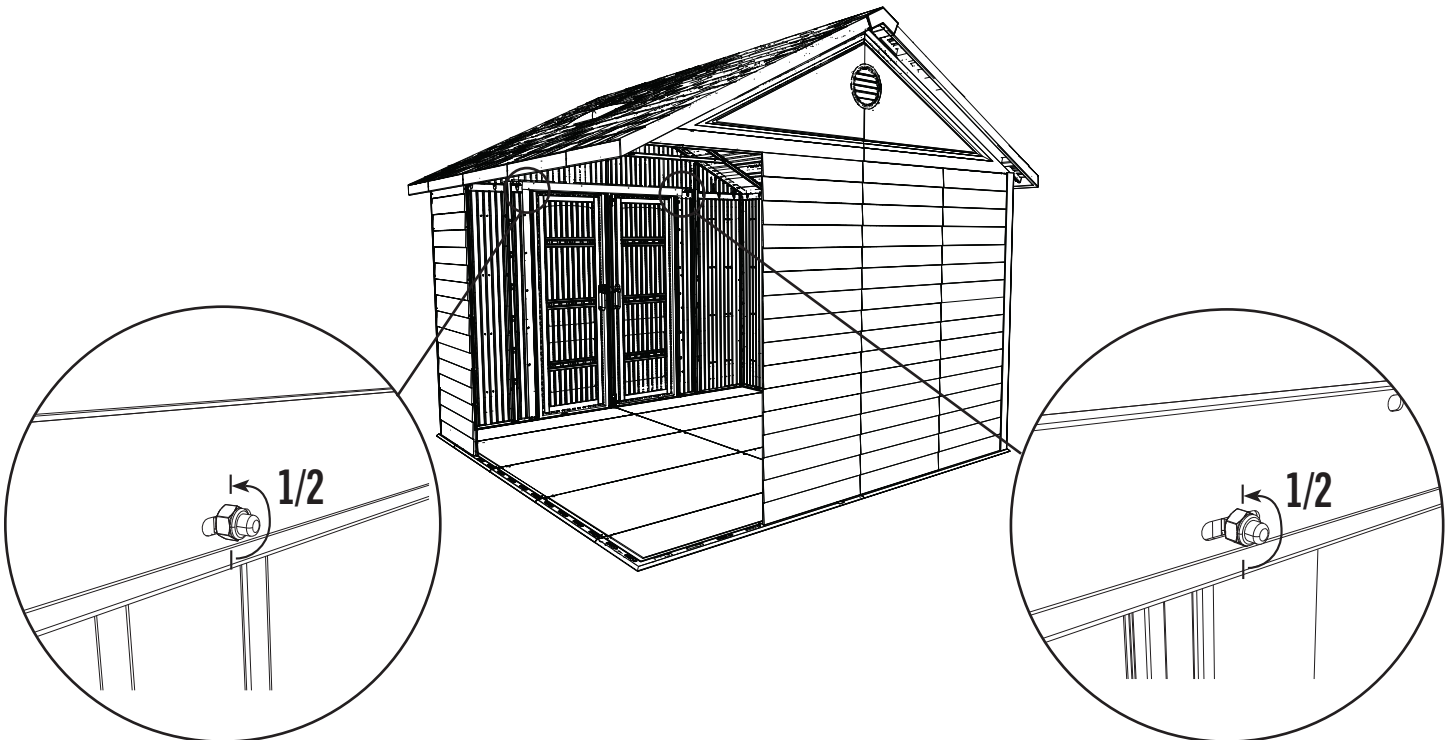

► SECTION 16 (CONTINUED) / SECTION 16 (SUITE) / SECCIÓN 16 (CONTINUACIÓN)

TOOLS AND PARTS REQUIRED / OUTILS ET PIÈCES REQUIS / INSTRUMENTAL Y HERRAJE REQUERIDOS



7/16 in/po
(≈11 mm)



16.3

- Loosen the screws along the hinges.
- Deserrez les dix vis le long des charnières.
- Afloje los diez tornillos a lo largo de las bisagras.

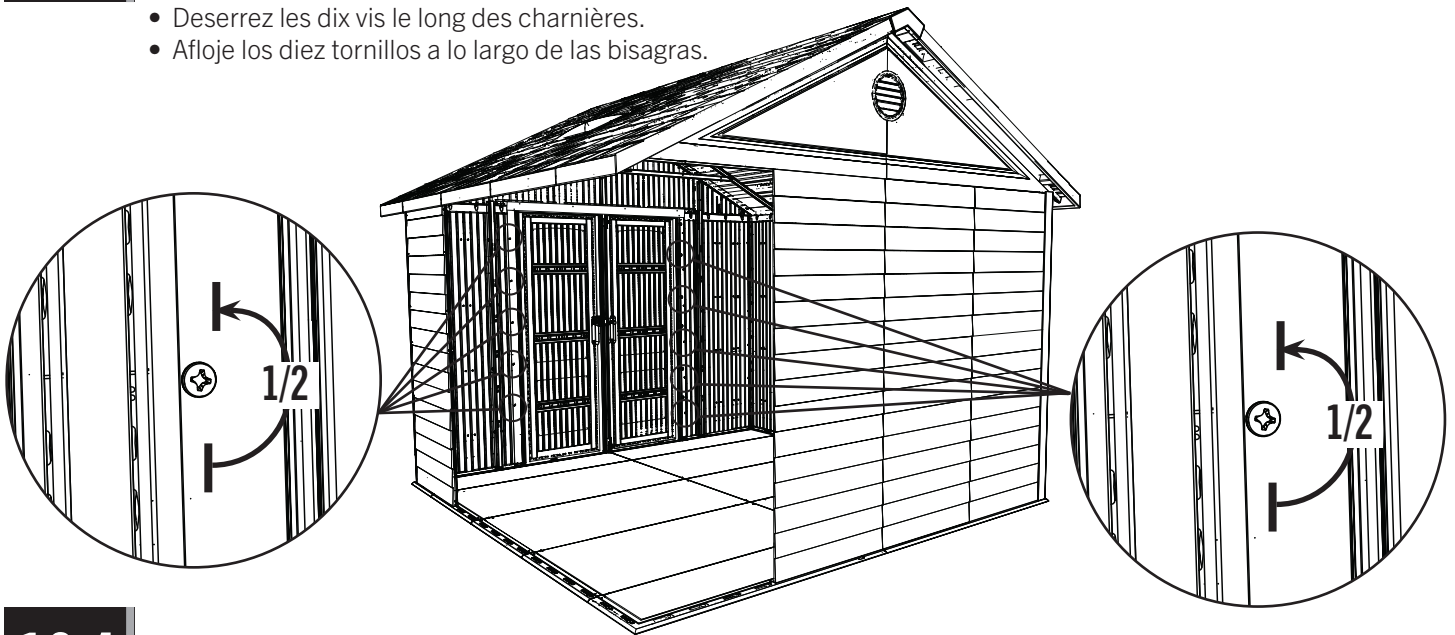

16.4

- Adjust the doors so they're parallel and retighten hardware. **Do not overtighten.**
- Ajustez les portes pour que soient parallèles et resserrez la quincaillerie. **Ne serrez pas trop.**
- Ajuste las puertas para que estén paralelos y re-apriete el herraje. **No lo apriete demasiado.**

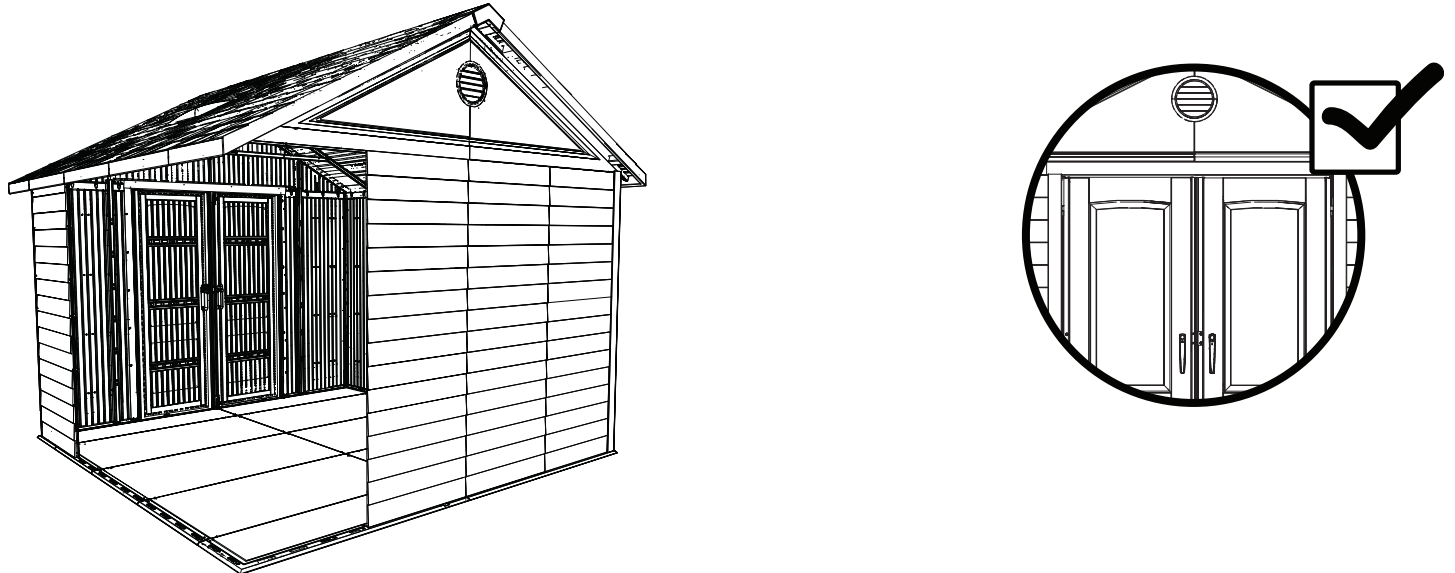



HARDWARE REQUIRED / QUINCAILLERIE REQUISE / HERRAJE REQUERIDO

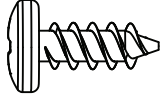

ADZ (x4)



PARTS REQUIRED / PIÈCES REQUISES / PIEZAS REQUERIDAS



TOOLS REQUIRED / OUTILS REQUIS / INSTRUMENTAL REQUERIDO

(Not included—unless otherwise indicated) / (Non inclus — sauf indication contraire*) / (No incluido, salvo indicación contratia*)*



7/16" (≈11 mm)

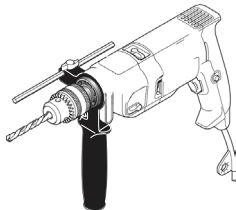

5/16" (≈8 mm) Wood drill bit
 ≈8 mm (5/16") Foret à bois
 ≈8 mm (5/16") Broca para madera



5/16" (≈8 mm) Masonry drill bit
 ≈8 mm (5/16") Foret à maçonnerie
 ≈8 mm (5/16") Broca para albañilería

► SECTION 17 (CONTINUED) / SECTION 17 (SUITE) / SECCIÓN 17 (CONTINUACIÓN)

TOOLS AND HARDWARE REQUIRED / INSTRUMENTAL Y HERRAJE REQUERIDOS / OUTILS ET QUINCAILLERIE REQUIS

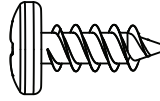

ADZ (x4)

17.1

- Insert two (2) screws (ADZ) through the hinge-to-floor brackets and into the floor at the bottom of the hinges as shown. **Proceed to step 17.2 for the anchoring steps for the wall support channels.**
- Insérez deux (2) vis (ADZ) à travers les supports pour la charnière à plancher et dans le plancher à la partie inférieure des charnières comme illustré. **Continuez à l'étape 17.2 pour voir comment ancrer les supports muraux.**
- Inserte dos (2) tornillos (ADZ) a través de los soportes para la bisagra al piso y dentro del piso al extremo inferior de las bisagras como se muestra. **Continue al paso 17.2 para ver como anclar los soportes murales.**

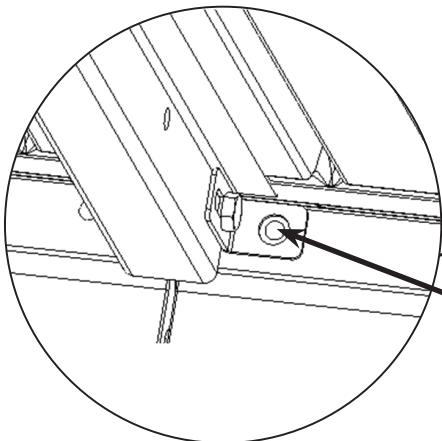
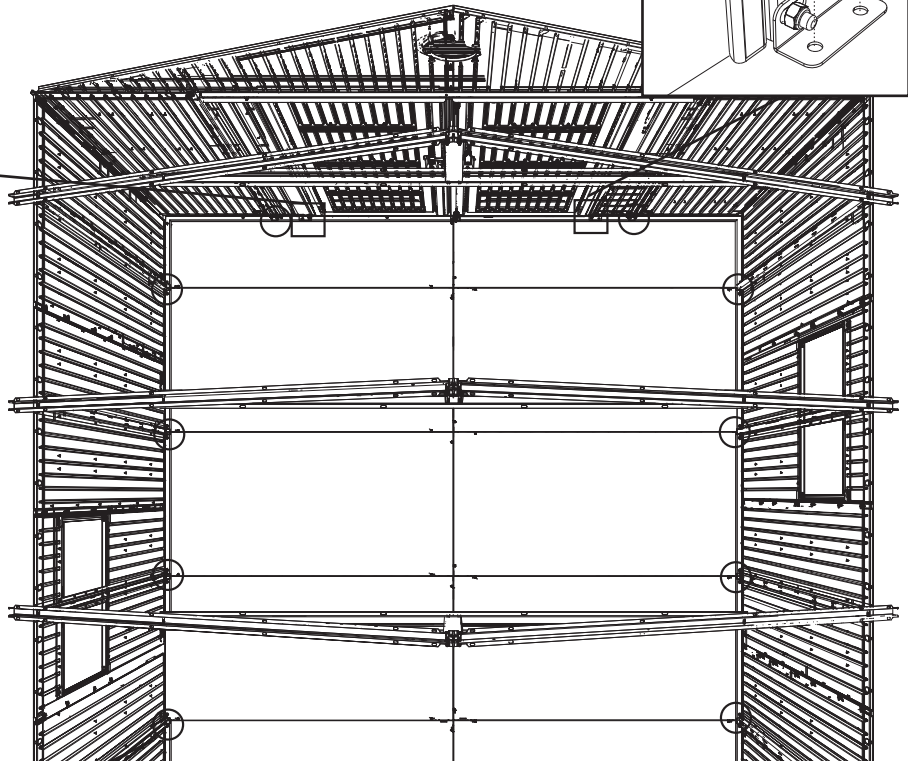
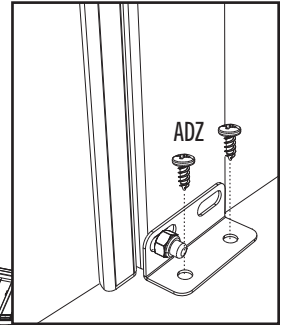
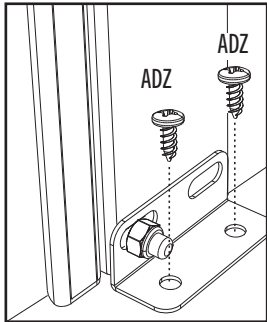

17.2

SECTION 17 (CONTINUED) / SECTION 17 (SUITE) / SECCIÓN 17 (CONTINUACIÓN)

FOR A CONCRETE PLATFORM / POUR UNE PLATE-FORME EN BÉTON / PARA UNA PLATAFORMA DE CONCRETO

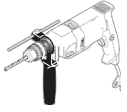

5/16 in/po
(≈8 mm)



17.2

- If you plan on anchoring your shed to a concrete platform, you must purchase the correct anchoring hardware. We recommend using a hammer drill, 5/16" (≈8 mm) masonry bit, sixteen (16) 3/8" x 2" (≈10 mm x ≈5 cm) concrete screws, and sixteen (16) 3/8" x 1" (≈10 mm x ≈2,5 cm) fender washers.
- Si vous désirez ancrer votre abri à une plate-forme en béton, il faut acheter la quincaillerie d'ancrage correcte. Nous recommandons que vous utilisiez une perceuse de percussion, un foret à maçonnerie de ≈8 mm (5/16 po), seize (16) vis d'ancrage à béton de ≈10 mm x ≈5 cm (3/8 po x 2 po), et seize (16) rondelles de protection de ≈10 mm x ≈2,5 cm (3/8 po x 1 po).
- Si desea anclar su caseta a una plataforma hecho de concreto, es necesario comprar el herraje de anclaje correcto. Recomendamos que use un martillo perforador, una broca de albañilería de ≈8 mm (5/16 in.), dieciséis (16) tornillos de anclaje para concreto de ≈10 mm x ≈5 cm (3/8 in. x 2 in.), y dieciséis (16) rondanas de protección de ≈10 mm x ≈2,5 cm (3/8 in. x 1 in.).



- Do not exceed a 3/8" (≈10 mm) diameter screw. Refer to your local hardware store for this hardware.
- Ne dépassez pas un diamètre de ≈10 mm (3/8 po). Votre quincaillerie du coin aura cette quincaillerie.
- No exceda un diámetro de ≈10 mm (3/8 in.). Refiérase a su ferretería local para obtener este herraje.

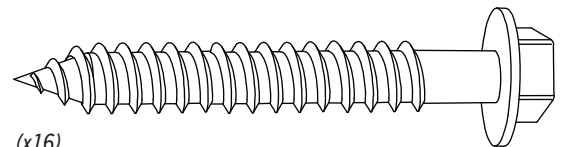
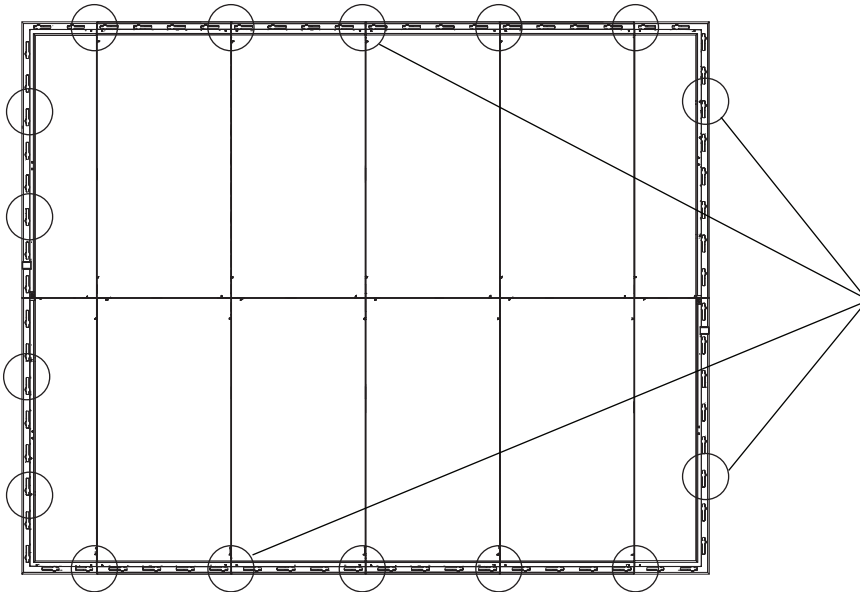

(x16)
(Not included) (Non incluses) (No incluidas)

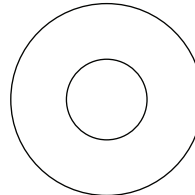

(x16)
(Not included) (Non incluses) (No incluidas)



WARNING / AVERTISSEMENT / ADVERTENCIA



- Failure to anchor the shed may result in property damage and/or personal injury.
- Si vous n'ancrez pas votre abri, des dommages à la propriété et/ou des blessures peuvent en résulter.
- No anclar la caseta puede resultar en daños a la propiedad y/o en lesiones personales.

SECTION 17 (CONTINUED) / SECTION 17 (SUITE) / SECCIÓN 17 (CONTINUACIÓN)

FOR A WOOD PLATFORM / POUR UNE PLATE-FORME EN BOIS / PARA UNA PLATAFORMA DE MADERA



5/16 in/po
(≈8 mm)

7/16 in/po
(≈11 mm)



17.2

- If you plan on anchoring your shed to a wood platform, you must purchase the correct anchoring hardware. We recommend using a drill, 5/16" (≈8 mm) drill bit, sixteen (16) 3/8" x 1 1/2" (≈10 mm x ≈4 cm) lag screws and sixteen (16) 3/8" x 1" (≈10 mm x ≈2,5 cm) fender washers.
- Si vous désirez ancrer votre abri à une plate-forme en bois, il faut acheter les accessoires d'ancrage corrects. Nous recommandons que vous utilisiez une perceuse électrique, un foret de ≈8 mm (5/16 po), seize (16) vis de retard de ≈10mm x ≈4 cm (3/8 po x 1 1/2 po), et seize (16) rondelles de protection de ≈10 mm x ≈2,5 cm (3/8 po x 1 po).
- Si desea anclar su caseta a una plataforma hecho de madera, es necesario comprar el herraje de anclaje correcto. Recomendamos que use un taladro eléctrico, una broca de ≈8 mm (5/16 in.), dieciséis (16) tornillos para madera de ≈10 mm x ≈4 cm (3/8 in. x 1 1/2 in.) y dieciséis (16) rondanas de protección de ≈10 mm x ≈2,5 cm (3/8 in. x 1 in.).



- Do not exceed a 3/8" (≈10 mm) diameter screw. Refer to your local hardware store for this hardware.
- Ne dépassez pas un diamètre de ≈10 mm (3/8 po). Votre quincaillerie du coin aura cette quincaillerie.
- No exceda un diámetro de ≈10 mm (3/8 in.). Refiérase a su ferretería local para obtener este herraje.

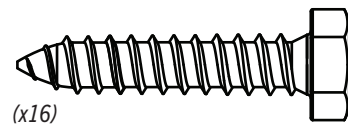
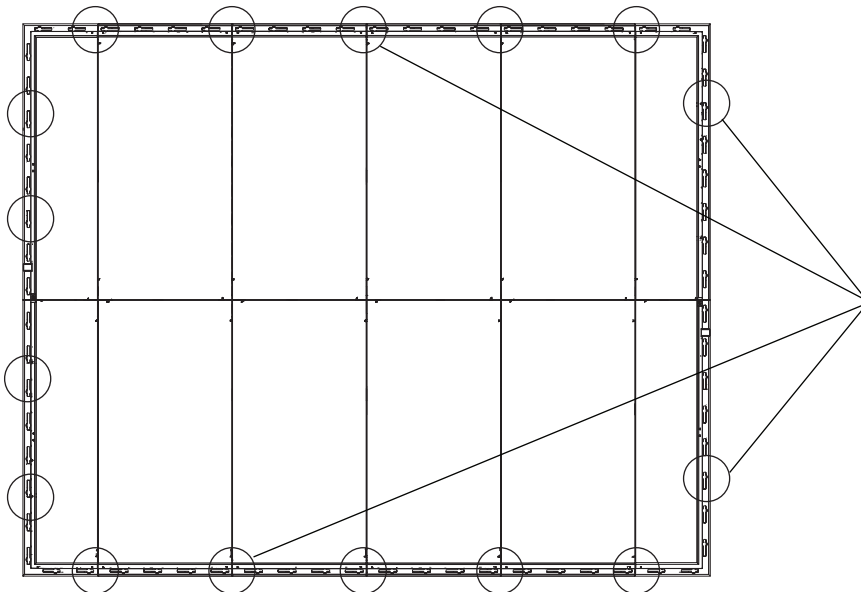

(x16)
(Not included) (Non incluses) (No incluidas)

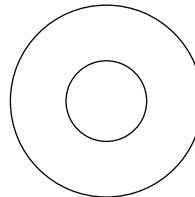

(x16)
(Not included) (Non incluses) (No incluidas)



WARNING / AVERTISSEMENT / ADVERTENCIA



- Failure to anchor the shed may result in property damage and/or personal injury.
- Si vous n'ancrez pas votre abri, des dommages à la propriété et/ou des blessures peuvent en résulter.
- No anclar la caseta puede resultar en daños a la propiedad y/o en lesiones personales.



NOTES / REMARQUES / NOTAS

A large, empty white rectangular area intended for writing notes or remarks.



NOTES / REMARQUES / NOTAS

A large, empty white rectangular area intended for writing notes or remarks.



NOTES / REMARQUES / NOTAS

A large, empty white rectangular area intended for writing notes or remarks.

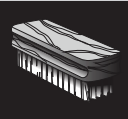

CLEANING & CARE

Congratulations on your Lifetime® product purchase. By following the instructions below, your new Lifetime product should provide you with years of service and enjoyment.

The polyethylene panels are stain and solvent resistant. Most stains can be removed using a mild soap and a soft-bristled brush. Abrasive cleaning materials may scratch the plastic and are not recommended. Repair scratches or rust spots on the metal by sanding the affected area lightly; using a rust preventative spray primer; and finally, spraying with a high-gloss spray enamel paint. Avoid placing a direct heat source on or near surfaces unless using a heat barrier.

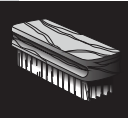

NETTOYAGE ET ENTRETIEN

Nous vous félicitons d'avoir acheté ce produit Lifetime®. En suivant les instructions ci-dessous, votre nouveau produit Lifetime devrait vous fournir des années de service et de plaisir.

Les murs et les étagères en polyéthylène sont résistants aux taches et solvants de nettoyage. Pour les nettoyer, se servir d'un savon doux et d'une brosse douce. Les produits abrasifs de nettoyage risquent d'égratigner le plastique et ne sont pas recommandés. Pour réparer les égratignures ou taches de rouille sur le métal, frotter légèrement l'endroit affecté au papier de verre, puis passer une couche de produit vaporisant préventif, et, enfin, vaporiser une peinture émail ultrabrillante. Éviter de placer une source de chaleur directe sur ou près des surfaces, ou les protéger à l'aide d'une protection contre la chaleur.



LIMPIEZA Y CUIDADO

Felicidades por la compra de su producto Lifetime®. Al seguir las siguientes instrucciones, su nuevo producto Lifetime le brindará años de servicio y satisfacción.

Los paneles de polietileno son resistentes a las manchas y solventes. La mayoría de las manchas puede removerse usando un jabón suave y un cepillo de cerdas suaves. Los materiales abrasivos para limpieza pueden rayar el plástico y no se recomiendan. Reparar rayones o manchas de óxido en el metal, lijando suavemente la parte afectada; usando un aerosol preventivo de óxido y finalmente, rociando con una pintura de esmalte brillante. Evitar poner una fuente de calor directa en o cerca de las superficies sin usar una barrera de calor.



REGISTER YOUR PRODUCT ONLINE AT WWW.LIFETIME.COM

At Lifetime®, we are committed to providing innovative and quality products. While registering, you will have the opportunity to give us your feedback. Your input is valuable to us.

- You can also opt in to receive new product notifications or promotions.
- In the unlikely event of a product recall or safety modification, your registration provides the information we need to notify you directly.
- Registration is fast, easy, and completely voluntary.

LIFETIME'S PROMISE TO YOU:

Maintaining your privacy is our long-standing policy at Lifetime®. And you can rest assured that Lifetime® will not sell or provide your personal data to other third parties, or allow them to use your personal data for their own purposes.

We invite you to read our privacy policy at www.lifetime.com

REGISTER today!



ENREGISTRER CE PRODUIT EN LIGNE À WWW.LIFETIME.COM

Chez Lifetime®, nous nous engageons à fournir des produits innovateurs de qualité. Lors de votre inscription, vous aurez l'occasion de nous faire parvenir vos commentaires. Votre opinion est importante pour nous.

- On peut également choisir de recevoir des avis ou des promotions dans le cadre de nouveaux produits.
- Dans l'éventualité improbable d'un rappel ou d'un avis de sécurité, l'inscription fournit les renseignements nécessaires nous permettant de communiquer avec vous.
- L'inscription est rapide, facile et complètement volontaire.

LA PROMESSE DE LIFETIME:

Conserver votre confidentialité est notre politique de longue date chez Lifetime®. Vous pouvez donc être rassuré par le fait que Lifetime® ne vendra pas ou ne fournira pas vos données personnelles à des tiers, et ne leur permettra pas d'utiliser vos données personnelles à leurs propres fins.

Nous vous invitons à lire notre politique de confidentialité à www.lifetime.com (en anglais seulement)

ENREGISTRER CE PRODUIT aujourd'hui!



REGISTRAR EL PRODUCTO EN LÍNEA EN WWW.LIFETIME.COM

En Lifetime®, estamos comprometidos a ofrecer productos innovadores y de calidad. Al registrarse, usted tendrá la oportunidad de darnos su retroalimentación. Su información es valiosa para nosotros.

- También puede optar por recibir nuestras notificaciones o promociones.
- En el caso improbable de que el producto deba ser retirado del mercado o que sufra alguna modificación, su registro provee la información que necesitamos para notificarle directamente.
- El registro es rápido, fácil y completamente voluntario.

LA PROMESA DE LIFETIME® PARA USTED:

Mantener privacidad es nuestra política permanente en Lifetime®. Y puede estar seguro que Lifetime® no venderá ni dará datos personales a terceros, ni les permitirá usar datos personales para sus propios fines.

Lo invitamos a leer nuestra política de privacidad en www.lifetime.com (sólo en inglés)

¡REGISTRARSE hoy mismo!



10-YEAR LIMITED FACTORY WARRANTY

THE MANUFACTURER RESERVES THE RIGHT TO MAKE SUBSTITUTIONS TO WARRANTY CLAIMS IF PARTS ARE UNAVAILABLE OR OBSOLETE.

Lifetime Lawn and Garden products are warranted to the original purchaser to be free from defects in material or workmanship for a period of 10 years from the date of original retail purchase. The word “defects” is defined as imperfections that impair the use of the product. Defects resulting from misuse, abuse or negligence will void this warranty. This warranty does not cover defects due to improper installation, alteration or accident. Lifetime recommends that no modifications be made to this product. This warranty does not cover damage caused by vandalism, rusting, “acts of nature”, natural disasters, normal wear and tear, or any other event beyond the control of the manufacturer.

This warranty is nontransferable and is expressly limited to the repair or replacement of defective products. If the product is defective within the terms of this warranty, Lifetime Products, Inc. will repair or replace defective parts at no cost to the purchaser. Shipping charges to and from the factory or distribution center are not covered and are the responsibility of the purchaser. Labor charges and related expenses for removal, installation or replacement of the product or its components are not covered under this warranty.

This warranty does not cover scratching, scuffing, or other cosmetic damage of the product that may result from normal usage. In addition, defects resulting from intentional damage, negligence, or unreasonable use will void this warranty / are not covered by this warranty.

Liability for incidental or consequential damages is excluded to the extent permitted by law. All merchandise is sold on this condition, and no representative of the company may waive or change this policy. This product is not intended for institutional or commercial use; Lifetime Products, Inc. does not assume any liability for such use. Institutional or commercial use will void the warranty.

This warranty is expressly in lieu of all other warranties, expressed or implied, including warranties of merchantability or fitness for use to extent permitted by Federal and state law. Neither Lifetime Products, Inc., nor any representative assumes any other liability in connection with this product. This warranty gives you specific legal rights, and you may also have other rights which vary from state to state.

Our goods come with guarantees that cannot be excluded under the Australian Consumer Law. You are entitled to a replacement or refund for a major failure and for compensation for any other reasonably foreseeable loss or damage. You are also entitled to have the goods repaired or replaced if the goods fail to be of acceptable quality and the failure does not amount to a major failure.

**ALL WARRANTY CLAIMS MUST BE ACCOMPANIED BY A SALES RECEIPT.
REPORT PRODUCT DEFECTS IN WRITING TO:**

LIFETIME PRODUCTS, INC.,
PO Box 160010
Freeport Center, Bldg. D-12
Clearfield, UT 84016-0010

For online warranty claims, please visit: www.lifetime.com/warranty
Warranty Department: (800) 225-3865

FOR INTERNATIONAL WARRANTY:

All warranty claims must be accompanied by a sales receipt. Report product defects in writing to your regional sales support representative. Please include your dated sales receipt and photographs of damaged parts.

To Identify the representative for your region, please visit: www.lifetime.com/international



GARANTIE DE FABRICATION LIMITÉE DE 10 ANS

LIFETIME® PRODUCTS, INC. RÉSERVE LE DROIT DE FAIRE DES SUBSTITUTIONS EN CAS DE RECOURS EN GARANTIE SI LES PIÈCES NE SONT PAS DISPONIBLES OU SONT OBSOLÈTES.

L'acheteur d'origine des produits pour pelouses et jardins de Lifetime bénéficie d'une garantie contre toute défectuosité de matériel et de fabrication pour une période de 10 ans à compter de la date d'achat. On entend par « défaut » une imperfection qui nuit à l'utilisation du produit. Tout défaut découlant d'une mauvaise utilisation, d'un abus ou d'une négligence a pour effet d'annuler cette garantie. Cette garantie ne couvre pas les défauts attribuables à une installation inadéquate, une altération ou un accident. Lifetime recommande de ne pas apporter de modifications à ce produit. Cette garantie ne couvre pas les dommages causés par le vandalisme, la corrosion par la rouille, les cas de « force majeure », les catastrophes naturelles, la détérioration et l'usure normales et tout autre événement indépendant de la volonté du fabricant.

Cette garantie n'est pas transférable et se limite expressément à la réparation ou au remplacement d'un produit défectueux. Si le produit est défectueux au sens de cette garantie, Lifetime Products, Inc. réparera ou remplacera les pièces défectueuses sans frais pour l'acheteur. Les frais d'expédition en partance ou en provenance de l'usine ou du centre de distribution ne sont pas couverts et incombent à l'acheteur. Les coûts relatifs à la main-d'œuvre et les autres frais liés au retrait, à l'installation ou au remplacement du produit ou de ses composants ne sont pas couverts par cette garantie.

Cette garantie ne couvre pas les rayures, les égratignures ou autres dommages esthétiques du produit découlant d'un usage normal. De plus, tout défaut découlant d'un dommage volontaire, de négligence ou d'un usage déraisonnable annule cette garantie et n'est pas couvert par cette garantie.

Dans la mesure permise par la loi, la société n'est pas responsable des dommages indirects ou accessoires. Toute marchandise est vendue à cette condition et aucun représentant de la société ne peut renoncer à l'application de cette politique ou la modifier. Ce produit n'est pas destiné à des fins institutionnelles ou commerciales; Lifetime Products, Inc. n'assume aucune responsabilité à cet égard. Toute utilisation institutionnelle ou commerciale annule la garantie.

La présente garantie remplace expressément toute autre garantie, expresse ou implicite, y compris les garanties de qualité marchande ou d'adaptation à un usage particulier dans la mesure permise par les lois du pays ou de l'État. Ni Lifetime Products, Inc. ni aucun de ses représentants n'assument une quelconque responsabilité en lien avec ce produit. Cette garantie vous donne des droits juridiques précis et vous pourriez également avoir d'autres droits selon l'État ou la province.

La garantie qui accompagne nos produits ne peut être exclue en vertu de la loi sur la protection du consommateur de l'Australie. Le client a droit à un remplacement ou à un remboursement en cas de bris majeur et pour toute autre perte ou dommage raisonnablement prévisible. Le client a aussi droit à ce que les produits soient réparés ou remplacés si un bris survient et rend la qualité inacceptable sans pour autant être qualifiable de bris majeur.

**TOUTE RÉCLAMATION EN VERTU DE LA GARANTIE DOIT ÊTRE ACCOMPAGNÉE D'UN REÇU DE VENTE.
SIGNALEMENT ÉCRIT DE TOUT PRODUIT DÉFECTUEUX:**

LIFETIME PRODUCTS, INC.,
PO Box 160010
Freeport Center, Bldg. D-12
Clearfield, UT 84016-0010

Pour effectuer en ligne une réclamation sous garantie, consultez cette adresse : www.lifetime.com/warranty
Service de la garantie : (800) 225-3865

GARANTIE INTERNATIONALE:

Toute réclamation en vertu de la garantie doit être accompagnée d'un reçu de vente. Veuillez signaler par écrit tout produit défectueux au représentant du soutien aux ventes de votre région. Veuillez inclure le reçu de vente daté ainsi que des photographies des pièces endommagées.

Pour connaître le représentant de votre région, veuillez consulter le : www.lifetime.com/international



GARANTÍA DE FÁBRICA LIMITADA POR 10 AÑOS

EL FABRICANTE SE RESERVA EL DERECHO DE HACER SUSTITUCIONES EN LOS ELEMENTOS REEMPLAZADOS BAJO GARANTÍA SI LAS PIEZAS NO ESTÁN DISPONIBLES O SON OBSOLETAS.

El comprador original recibe una garantía de que los productos de césped y jardín de Lifetime están libres de defectos de material o mano de obra durante un período de 10 años a partir de la fecha de compra original al por menor. La palabra “defectos” se define como imperfección que imposibilita el uso del producto. Los defectos ocasionados por el mal uso, el abuso o la negligencia anularán esta garantía. Esta garantía no cubre los defectos debidos a una instalación incorrecta, una alteración o un accidente. Lifetime recomienda que no se realicen modificaciones en este producto. Esta garantía no cubre los daños causados por vandalismo, oxidación, “actos de la naturaleza”, desastres naturales, desgaste normal o cualquier otro evento fuera del control del fabricante.

Esta garantía no es transferible y se limita expresamente a la reparación o reemplazo de productos defectuosos. Si el producto resulta defectuoso dentro de los términos de esta garantía, Lifetime Products, Inc. reparará o reemplazará las piezas defectuosas sin costo alguno para el comprador. Los gastos de envío hacia y desde la fábrica o el centro de distribución no están cubiertos y son la responsabilidad del comprador. La mano de obra y los gastos relacionados por la remoción, la instalación o la sustitución del producto o sus componentes no están cubiertos por esta garantía.

Esta garantía no cubre los rayones, los raspones ni otros daños superficiales del producto que pueden resultar del uso normal. Asimismo, los defectos resultantes de daños intencionales, negligencia o uso indebido anularán o no están cubiertos por esta garantía.

Se excluye la responsabilidad por daños imprevistos o derivados en la medida en que lo permita la ley. Toda la mercancía se vende bajo estas condiciones y ningún representante de la empresa puede renunciar a ni cambiar esta política. Este producto no está destinado para uso institucional o comercial; Lifetime Products, Inc. no asume ninguna responsabilidad por dicho uso. El uso institucional o comercial anulará la garantía.

Esta garantía sustituye expresamente cualquier otra garantía, expresa o implícita, incluidas las garantías de comercialización o idoneidad para su uso en la medida permitida por la ley federal y estatal. Ni Lifetime Products, Inc., ni ningún representante asume ninguna otra responsabilidad en relación con este producto. Esta garantía le otorga derechos legales específicos y usted también puede tener otros derechos que varían de un estado a otro.

Nuestros productos vienen con garantías que no se pueden excluir bajo la Ley Australiana del Consumidor. Usted tiene derecho a recibir un reemplazo o reembolso por un fallo grave y compensación por cualquier otra pérdida o daño razonablemente previsible. También tiene derecho a la reparación o el reemplazo de los bienes si los bienes no son de calidad aceptable y el fallo no supone un fallo grave.

TODOS LOS RECLAMOS DE GARANTÍA DEBEN ESTAR ACOMPAÑADOS POR UN RECIBO DE COMPRA. REPORTE LOS DEFECTOS DEL PRODUCTO POR ESCRITO A:

LIFETIME PRODUCTS, INC.,
PO Box 160010
Freeport Center, Bldg. D-12
Clearfield, UT 84016-0010

Para realizar reclamos de garantía por internet, visite: www.lifetime.com/warranty.
Departamento de Garantías: (800) 225-3865

PARA LA GARANTÍA INTERNACIONAL:

Todos los reclamos de garantía deben estar acompañados por un recibo de compra. Reporte los defectos del producto por escrito a su representante regional de apoyo de ventas. Por favor, incluya su recibo de compra con la fecha y fotografías de las piezas dañadas.

Para identificar al representante de su región, por favor visite: www.lifetime.com/international

GARANTIA NO VÁLIDA EN MÉXICO

ENHANCE YOUR LIFETIME® PURCHASE BY ADDING ACCESSORIES OR OTHER GREAT PRODUCTS

To purchase accessories or other Lifetime® products, visit us at:

www.lifetime.com

Or call: 1-800-424-3865

AMÉLIORER L'ACHAT LIFETIME® EN AJOUTANT DES ACCESSOIRES OU D'AUTRES PRODUITS

Pour acheter des accessoires ou des autres produits Lifetime®, visiter le :

www.lifetime.com

Ou composer le 1-800-424-3865

MEJORAR LA COMPRA DE LIFETIME® AGREGANDO ACCESORIOS U OTROS MARAVILLOSOS PRODUCTOS

Para comprar accesorios u otros productos de Lifetime®, visitarnos en:

www.lifetime.com

O marcar al 1-800-424-3865



www.lifetime.com

