

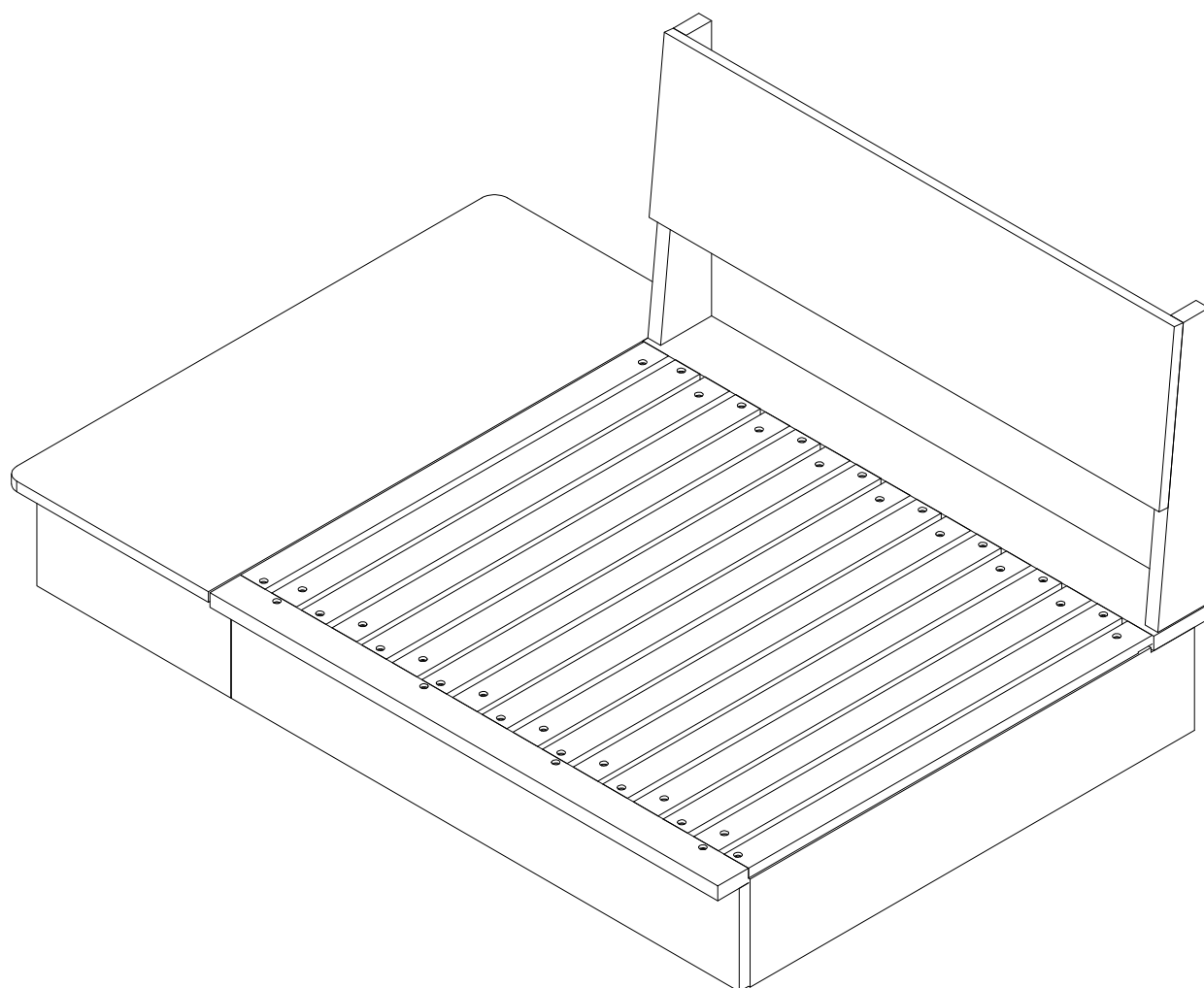

Assembly Guide





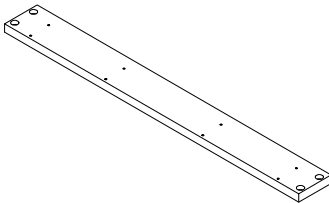
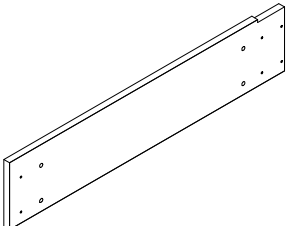
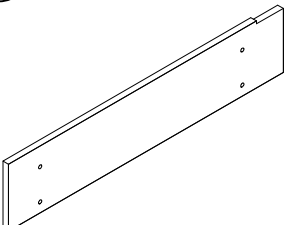
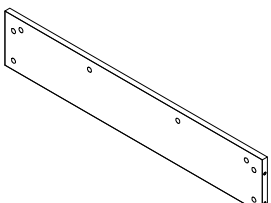
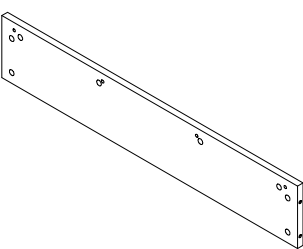
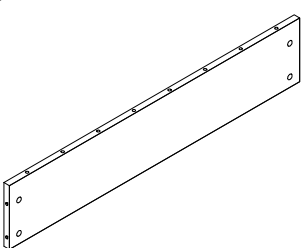
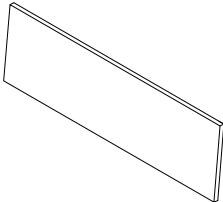
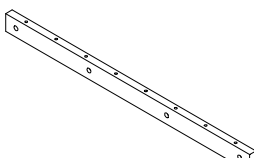
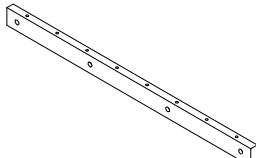
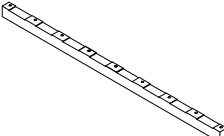
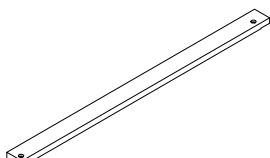
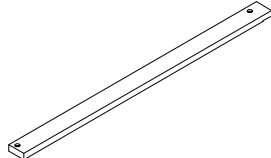
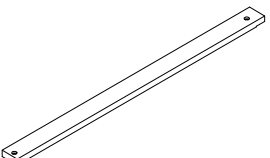
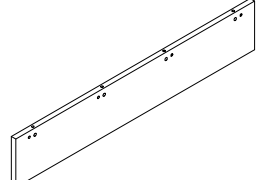
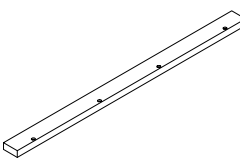
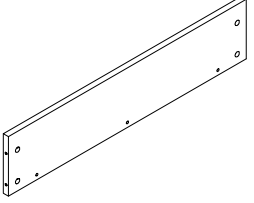
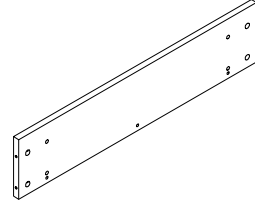
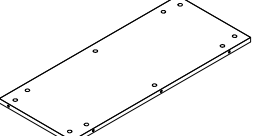
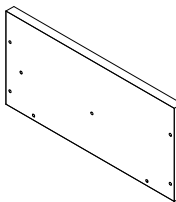
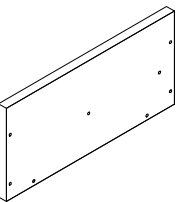
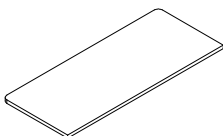

S2311K-1.4 meter sofa bed

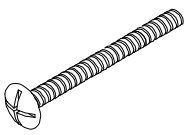
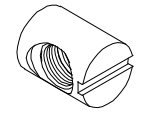
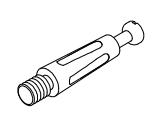

PARTS LIST

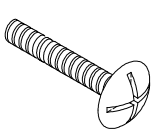
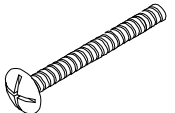
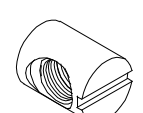
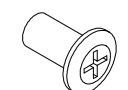
①	②	③	④	
				
left back cube=1	right back cube=1	back panel=1	left side panel=1	
⑤	⑥	⑦	⑧	
				
right side panel=1	back plate=1	back plate=1	partition panel=1	
⑨	⑩	⑪	⑫	⑬
				
back panel=1	strip(962)=1	strip(958)=1	pine bottom strip=1	left seat batten=1
⑭	⑮	⑯	⑰	⑱
				
right seat batten=1	seat batten=15	front panel=1	front panel=1	side panel=1
⑲	⑳	㉑	㉒	㉓
				
side panel=1	bottom panel=1	side panel=1	side panel=1	lifting panel=1

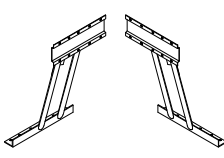
HARDWARE LIST

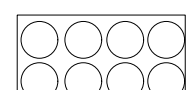
A	B	C	D	E
				
8*55 big flat screws=8	8mm hammer nuts=4	3 in 1 rods=36	3 in 1 camlocks=36	6mm gaskets=50
F	G	H	I	J
				
6*25 big flat screws=44	6*50 big flat screws=8	6mm hammer nuts=8	6mm screw nut=16	6*30 full-thread screws=8
K	L	M	N	
				
lifter rack=1 set	4*16 self-tapping screws=20	wool pad=20	hole stickers=25	

Tips: Do not throw away packing materials until assembly is complete for small parts may come loose inside the carton during shipment. If parts are missing, please contact us. Assemble this item on a soft surface, such as carpet to protect the finish.

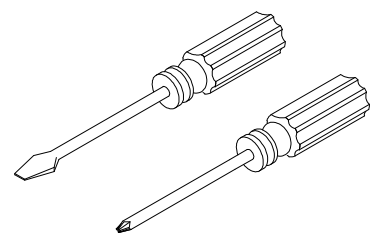

phillips head screw driver required for assemble---not include

Step 1

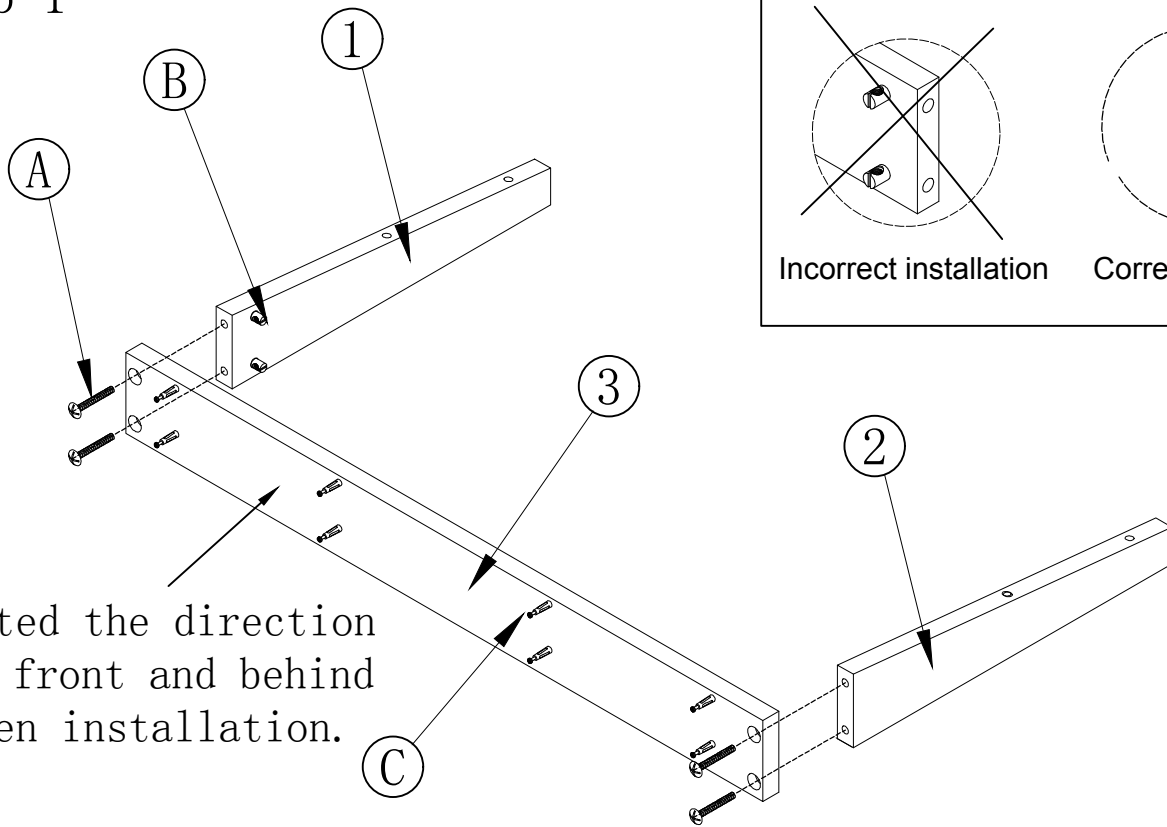

Noted the direction
of front and behind
when installation.

1. Pre-install 8 pcs (C) on panel ③.
2. Connect panel ①②③ with 4 pcs (A) and 4 pcs (B).

Step 2

Connect panel ④⑤
⑥⑦⑧ with 12
pcs (C) and 12 pcs (D).

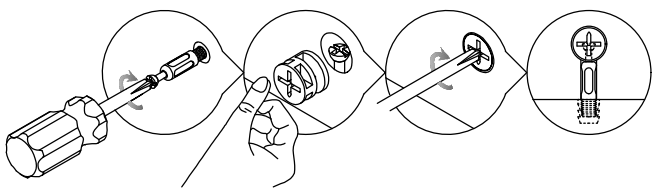
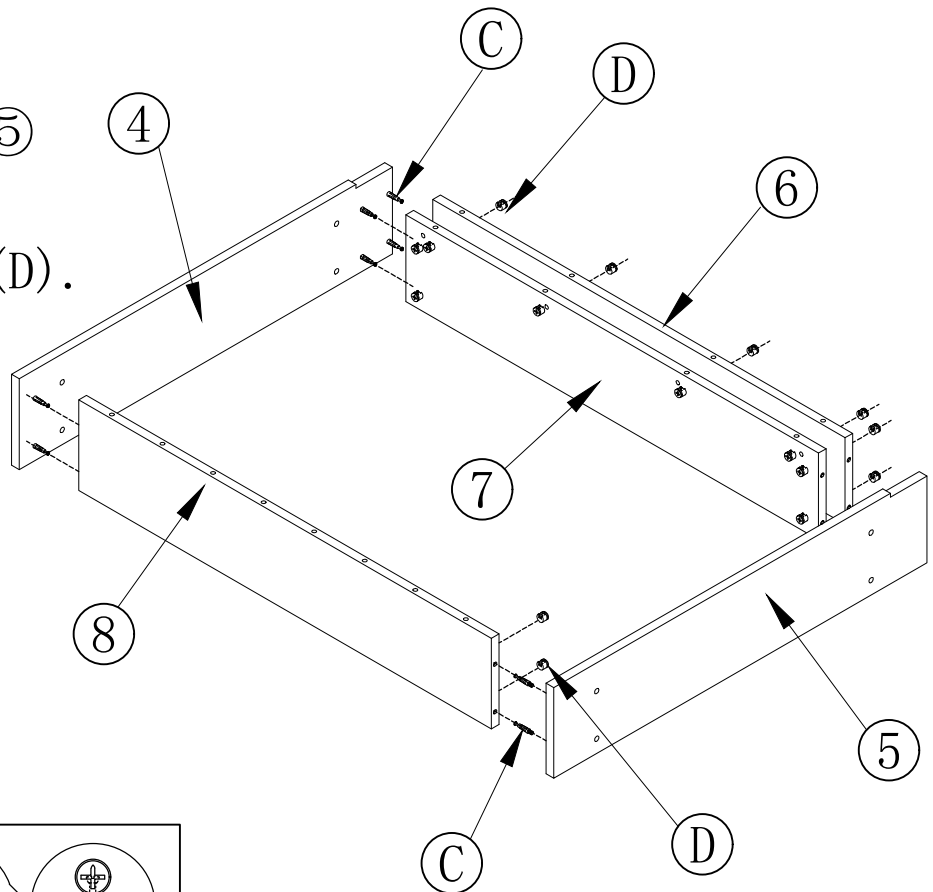

Step 3

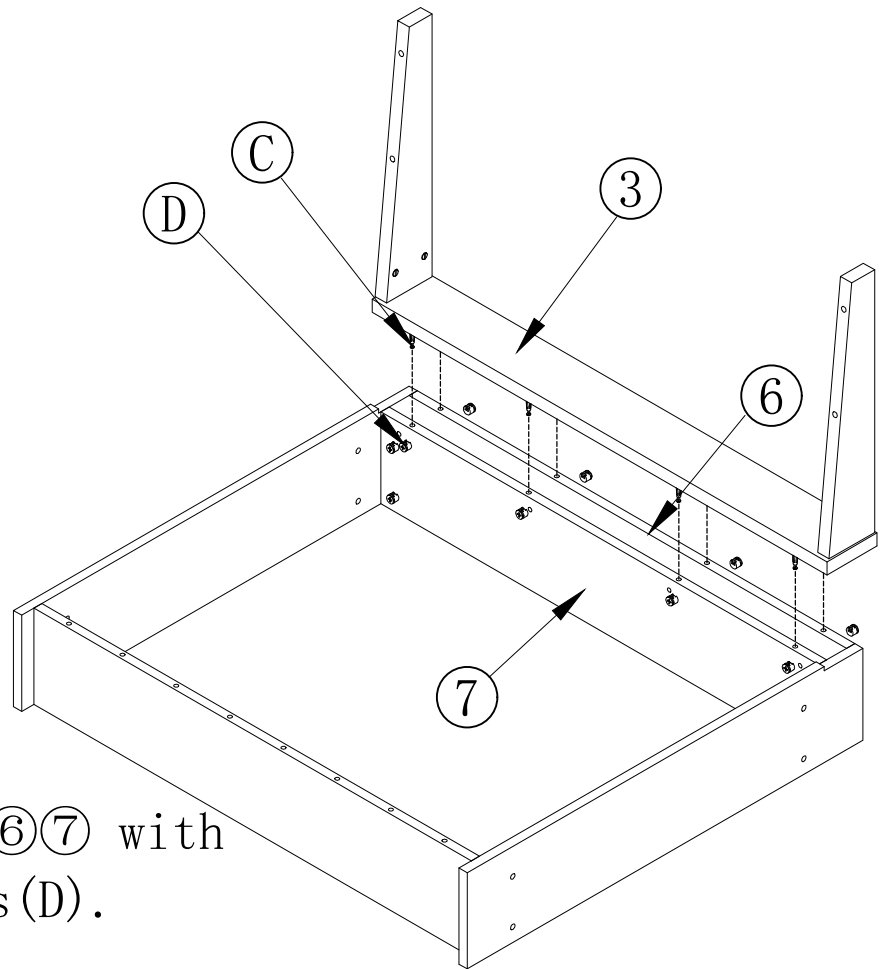

Connect panel ③⑥⑦ with
8 pcs (C) and 8 pcs (D).

Step 4

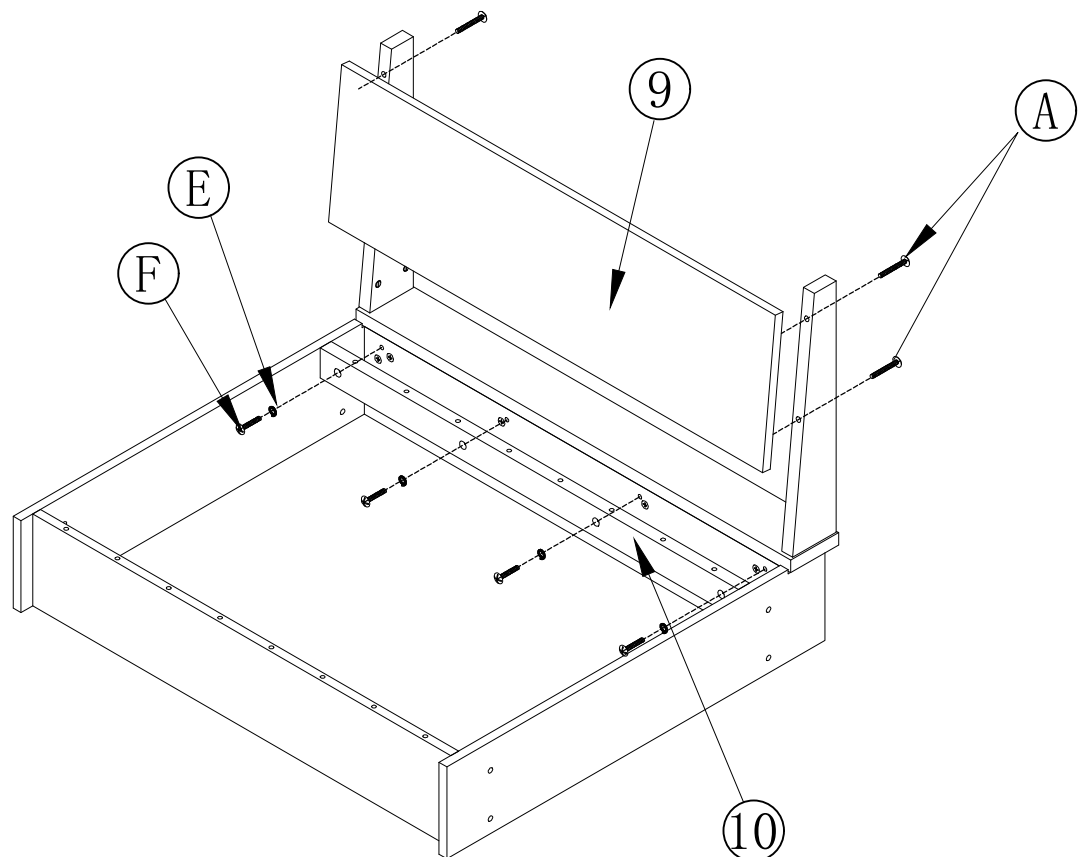

1. Connect panel ⑨ with 4 pcs (A).
2. Connect panel ⑩ with 4 pcs (E) and 4 pcs (F).

Step 5

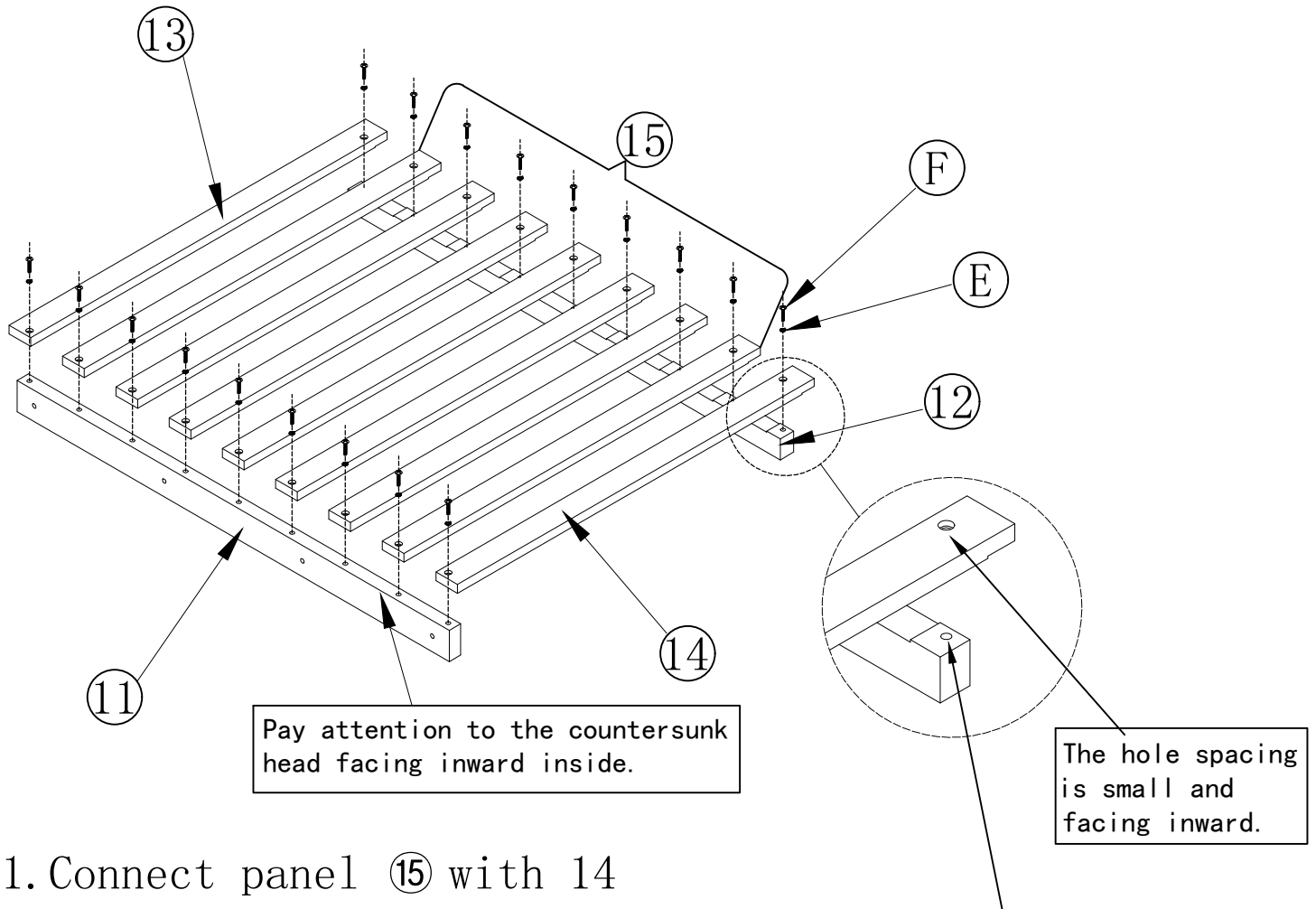

1. Connect panel ⑮ with 14 pcs (E) and 14 pcs (F), total 7 pieces.
2. Connect panel ⑬⑭ with 4 pcs (E) and 4 pcs (F).

Pay attention to the direction of the hole.

Step 6

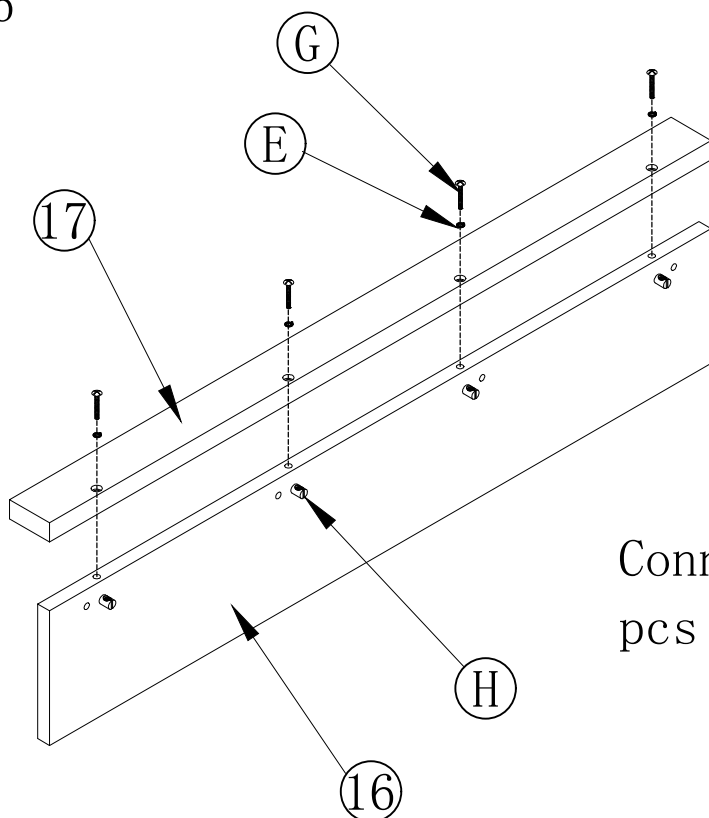

Connect panel ⑯⑰ with 4 pcs (E), 4 pcs (G) and 4 pcs (H).

Step 7

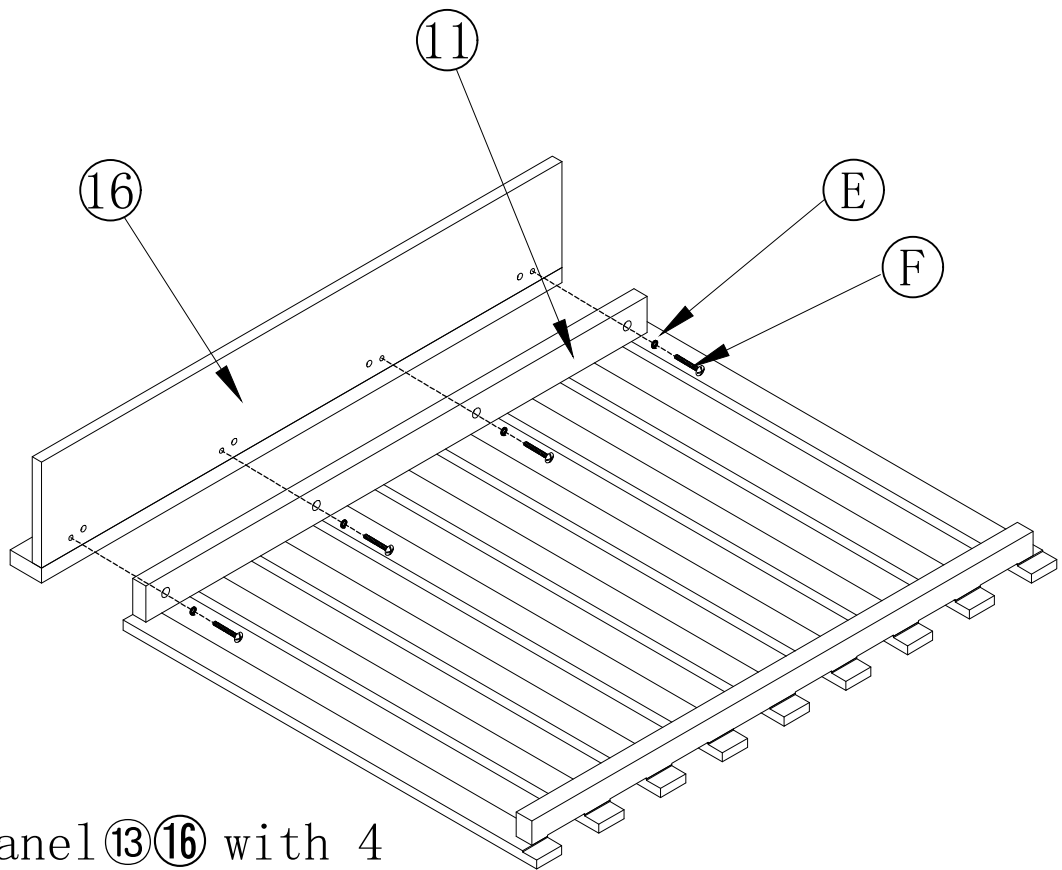

Connect panel ⑬⑯ with 4 pcs (E) and 4 pcs (F).

Step 8

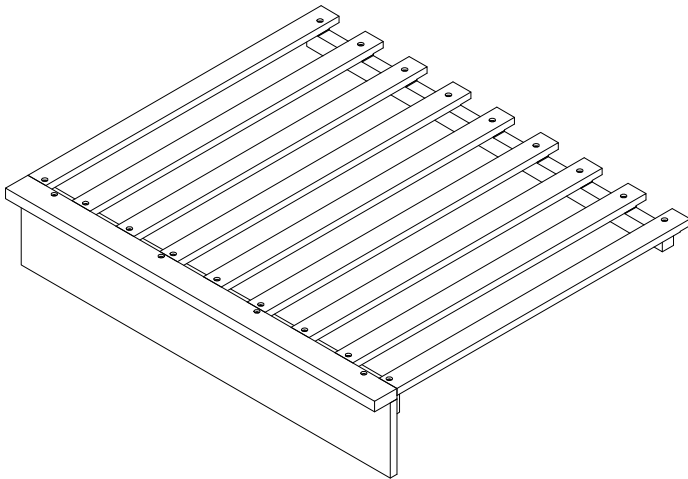

The assembled movable
frame

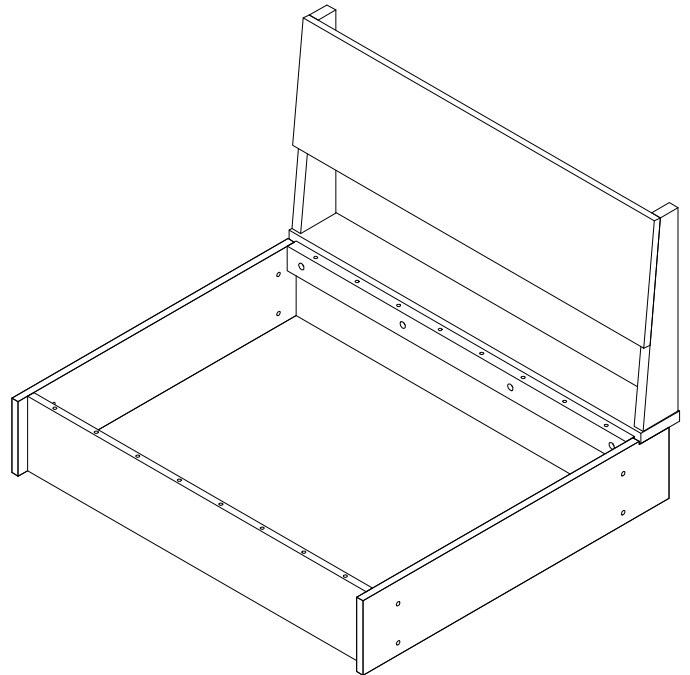

The assembled fixed
frame

Step 9

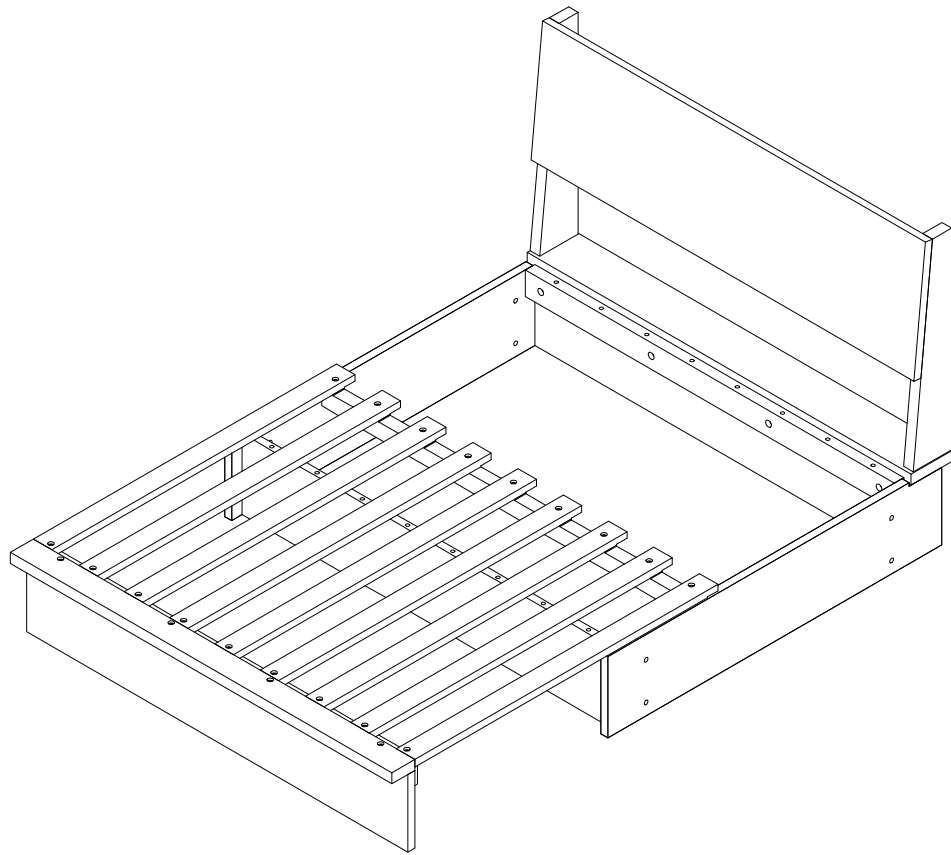

Put the movable frame on the fixed frame first.

Step 10

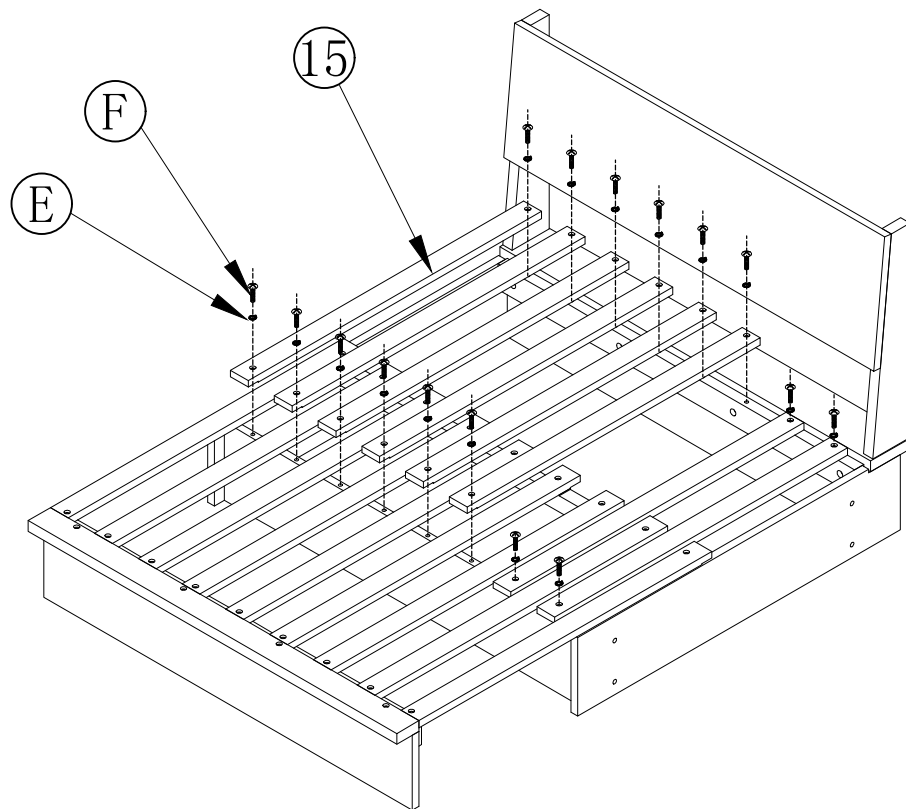

And then put the panel ⑮, total eight pieces. Alignment hole position, connect them with 16 pcs (E) and 16 pcs (F).

Step 11

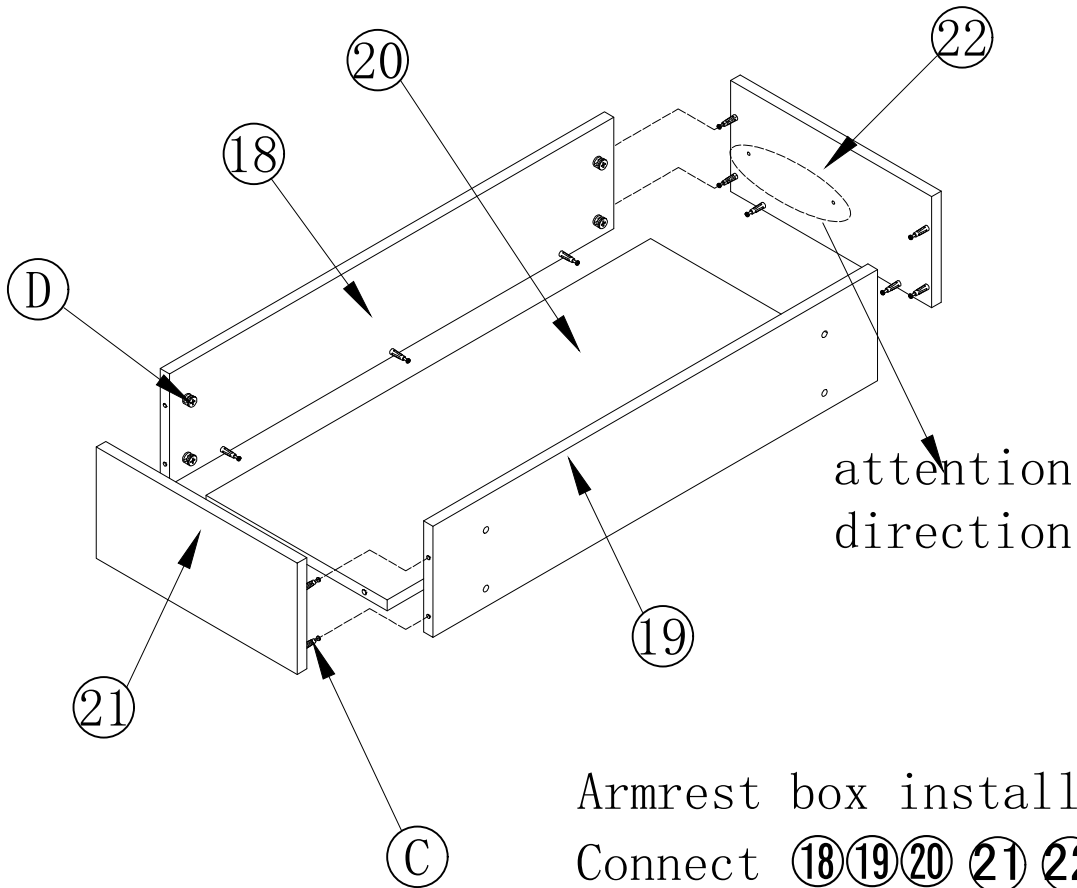

Armrest box installation:
Connect ⑱⑲⑳㉑㉒ with 8 pcs (C) and 8 pcs (D).

Step 12

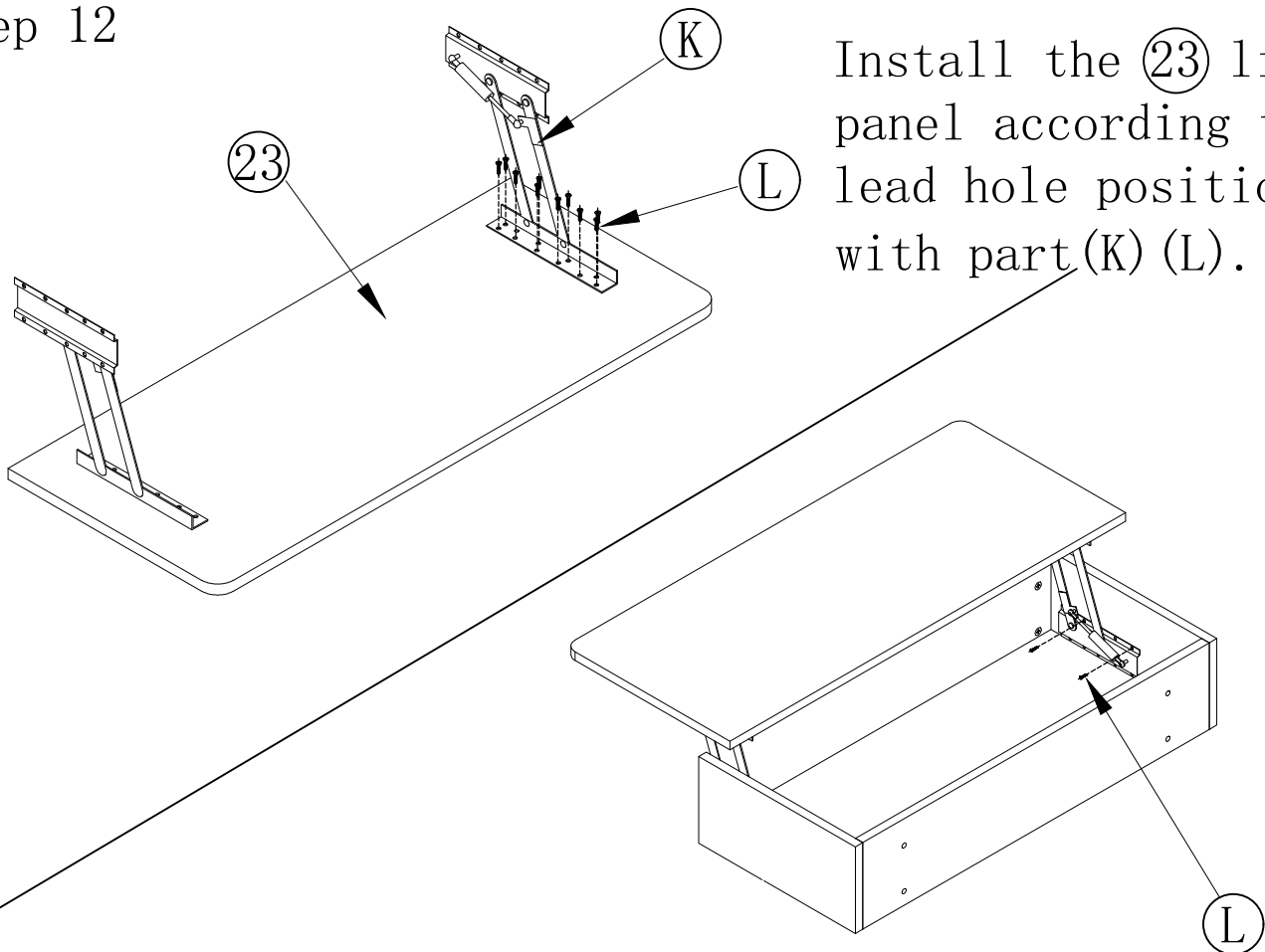

Install the ㉓ lifting panel according to the lead hole position with part (K) (L).

Step 13

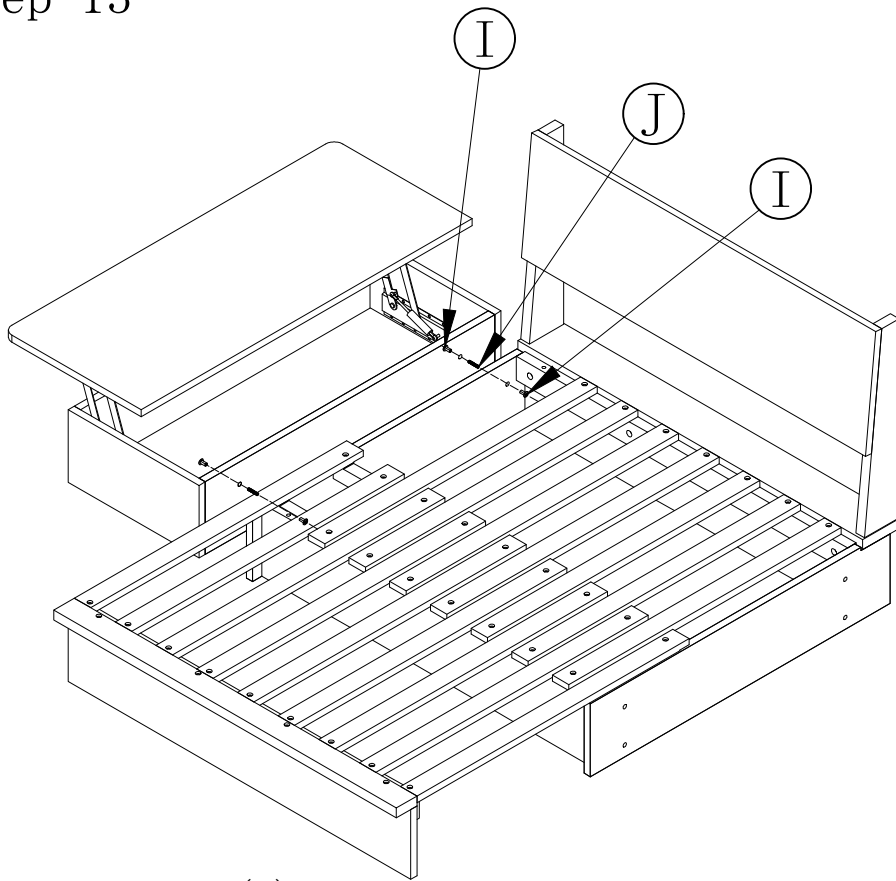

1. Stick the (M) on the bottom.
2. Lay the sofa frame and armrest box flat, hole to hole, then use part (I) (J) to connect.

Step 14

Turn the two sofa upside down, aligning, then connect them with part (I) (J).

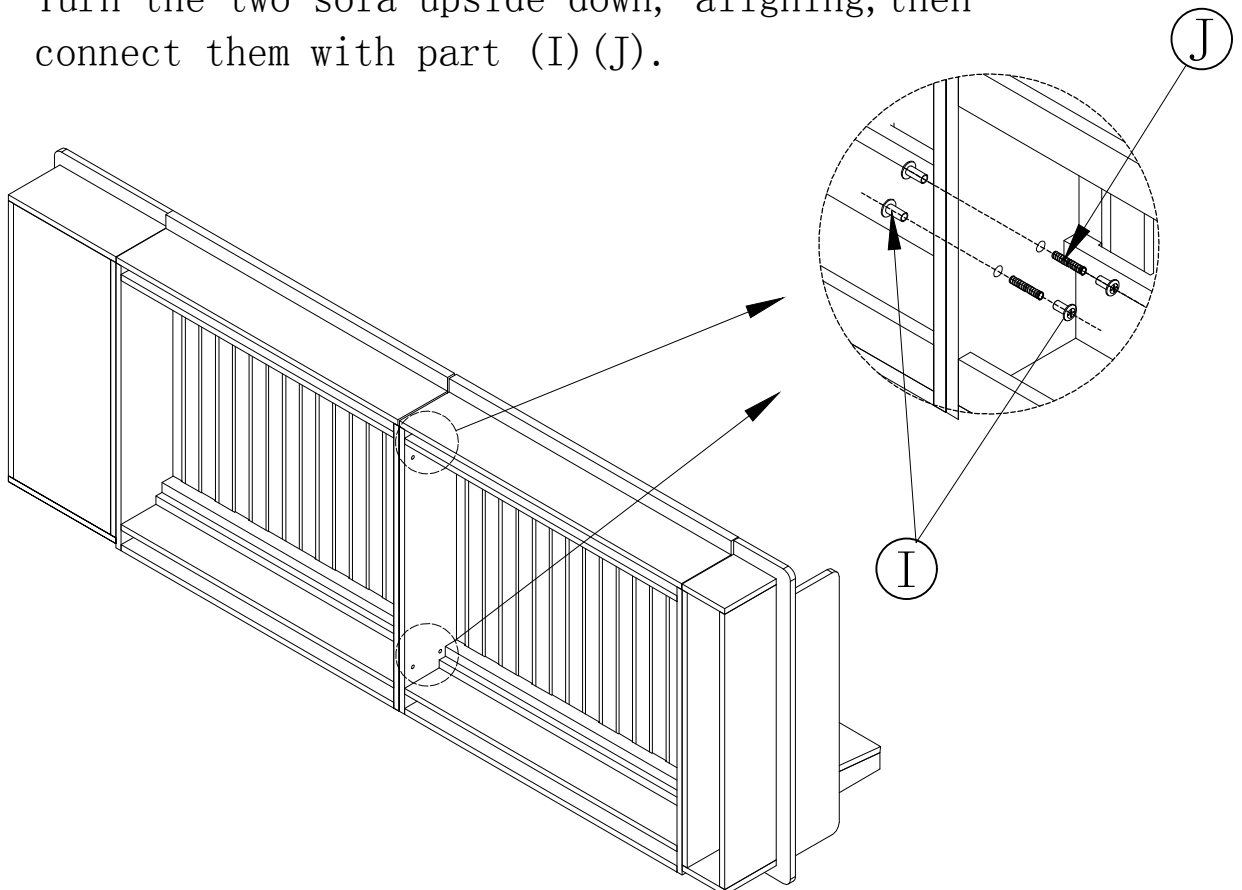

Step 15

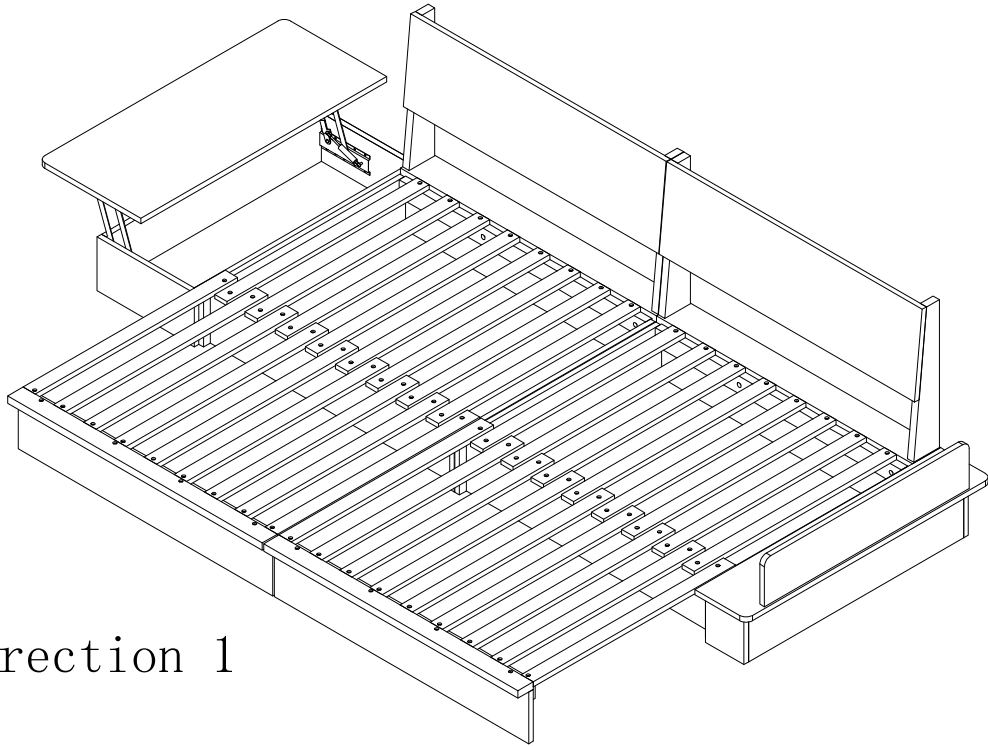

Direction 1

Step 16

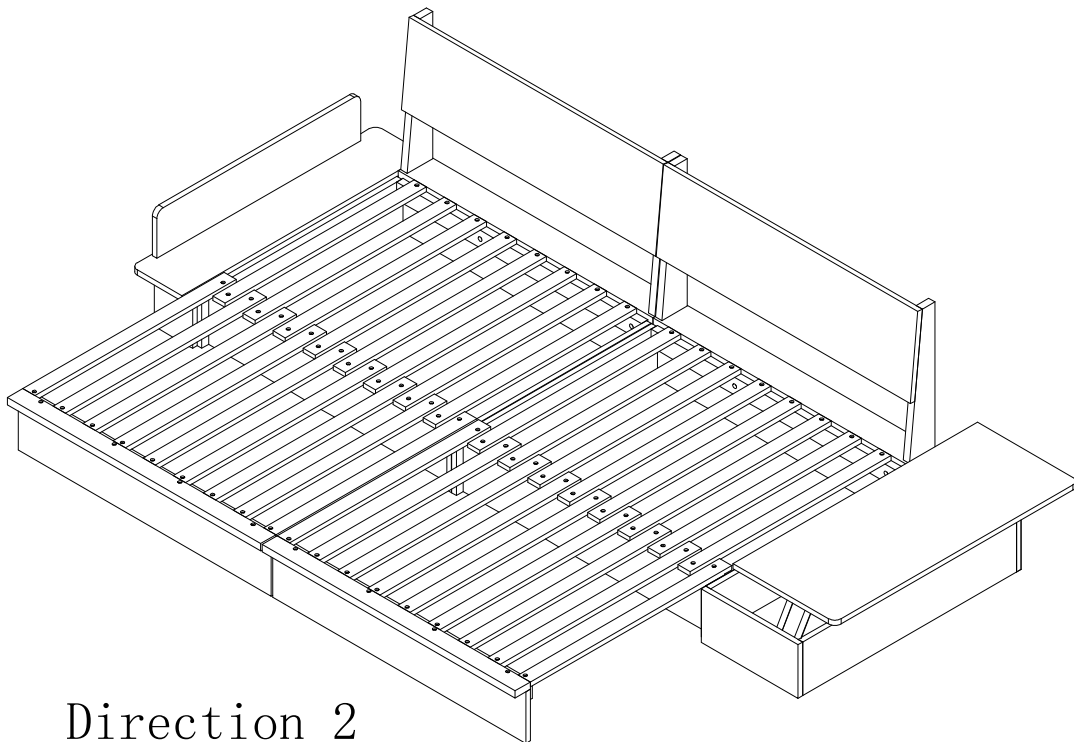

Direction 2