

ASSEMBLY INSTRUCTIONS

WF294355

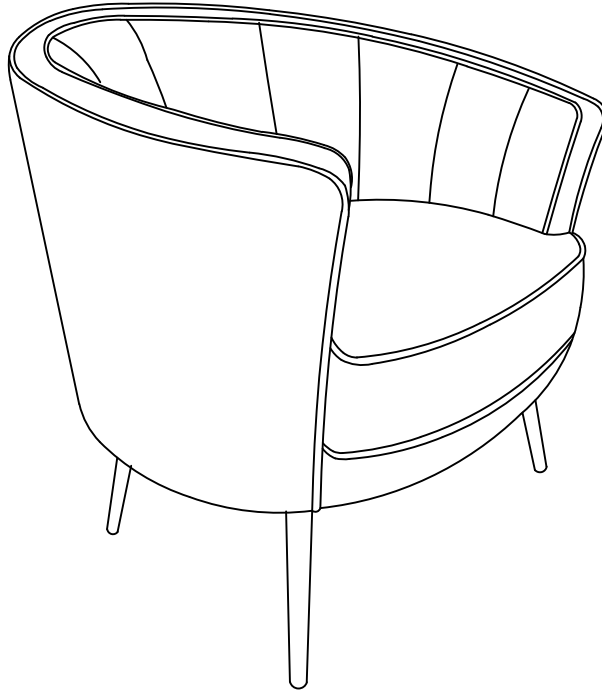

IMPORTANT NOTE

****PLACE ALL PARTS ON A CLEAN AND SMOOTH SURFACE SUCH AS A RUG OR CARPET TO AVOID THE PARTS FROM BEING SCRATCHED**

**** BEFORE YOU BEGIN , KINDY FOLLOW THE ASSEMBLY INSTRUCTIONS STEP BY STEP**

****DO NOT TIGHTEN ALL BOLTS UNTIL THE CHAIR IS FULLY SET-UP**

ASSEMBLY INSTRUCTIONS

WF294355

PARTS IDENTIFICATION

B1(BOX1)

1 Chair Cusion

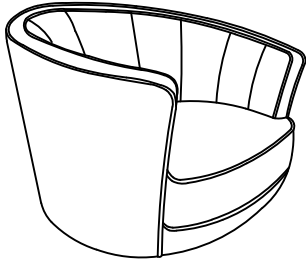

1pc

2 Leg



4pcs

HARDWARE IDENTIFICATION

A

Bolt
(Ø 5/16 "X25mm)



8pcs

B

Spring Washer
(Ø 5/16 "-RBW)



8pcs

C

Flat Washer
(Ø 5/16 "-RBW)



8pcs

D

Allen Wrench
(M4x75mm x32mm)





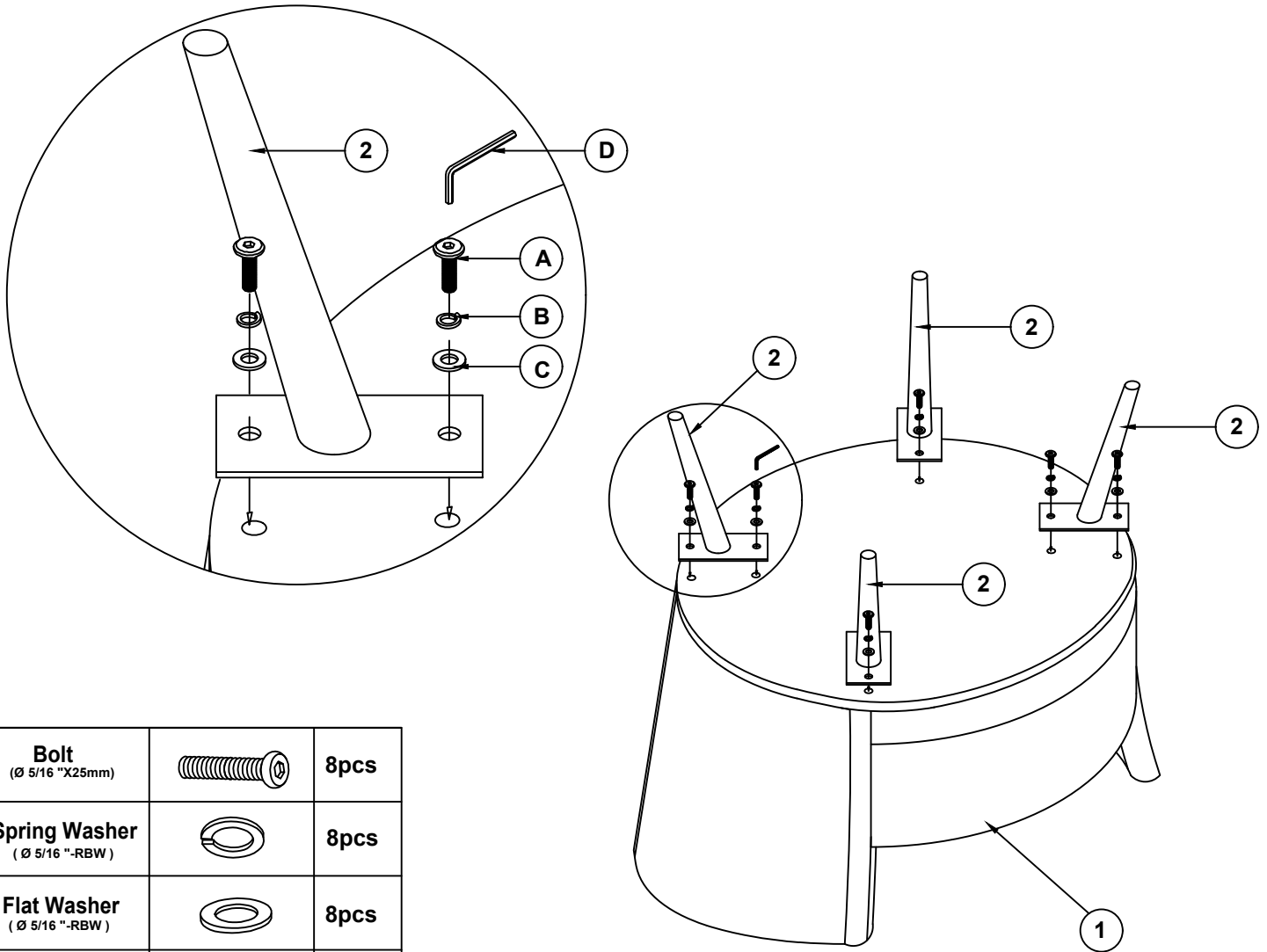

1pc

ASSEMBLY INSTRUCTIONS

STEP 1



A	Bolt (Ø 5/16 "X25mm)		8pcs
B	Spring Washer (Ø 5/16 "-RBW)		8pcs
C	Flat Washer (Ø 5/16 "-RBW)		8pcs
D	Allen Wrench (M4x75mm x32mm)		1pc

Step 2 : Completed Assembly .

