

ASSEMBLY INSTRUCTIONS

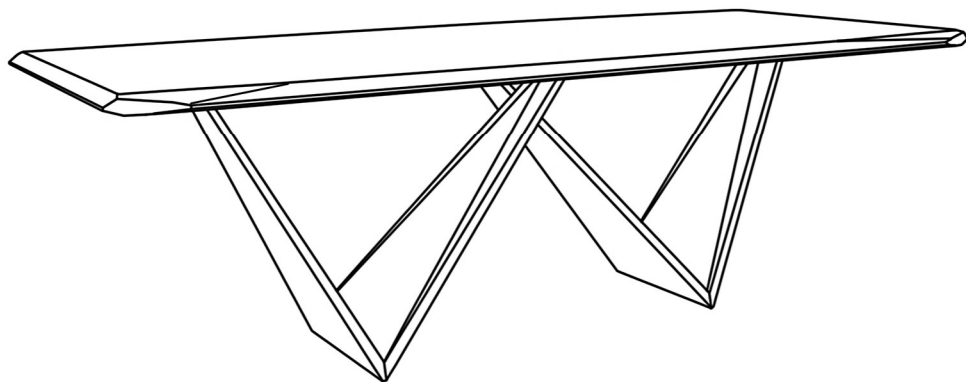

TOOLS REQUIRED

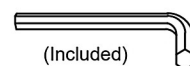

(Included)

Allen Wrench



2 - People

ASSEMBLY RATING



EASY ————— DIFFICULT

The Assembly Rating is a 5-point system showing the level of effort needed to assemble a specific product.



CHECK BEFORE STARTING

Are you missing anything?

Double-check all parts, hardware and accessories listed are all accounted for.

Check out our Quick Tips!

We recommend reviewing the pre-assembly handouts. Even experts need a refresher now and then!

Should we send any replacements?

Are there any irregularities or flaws in the parts? We can send replacements!

Prep Time!

Please review the assembly instructions and all diagrams prior to assembling.

PRE ASSEMBLY INTRODUCTION

We understand building ready-to-assemble furniture can be a challenging experience for some. To help avoid confusion, we have provided some helpful tips that may speed up the process.



Teamwork

ALWAYS have at least two people to help with transporting and assembling the product to avoid potential injury and/or damage.

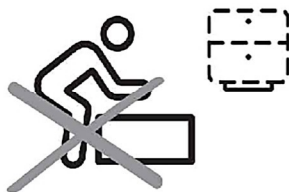

Suitable Location

Assembling near the area of the intended location is highly recommended.



Sufficient Space

Make sure you have enough space to move around during the assembly.



Avoid Scratches

Use cardboard, blankets or a carpeted area while assembling furniture to prevent to prevent scratches and damages.

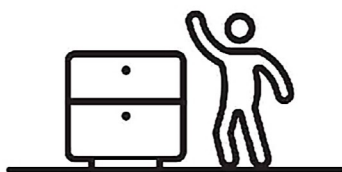
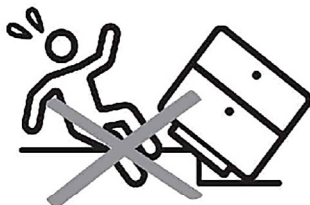

Flat Surface

Make sure the furniture rests on a flat and level surface with each leg evenly touching the floor.

ASSEMBLY AND CARE ADVICE



FAILURE TO FOLLOW THE GUIDELINES BELOW MAY RESULT IN INJURY AND/OR PROPERTY DAMAGE.

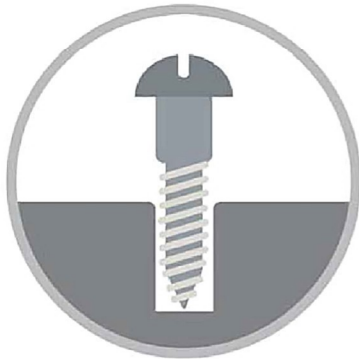

Position each part correctly and insert screws or bolts into their respective holes.



Use the appropriate hand tools or power tools for assembly. Select steps, such as tightening screws and/or bolts, may require hand tools to avoid causing damage during assembly.

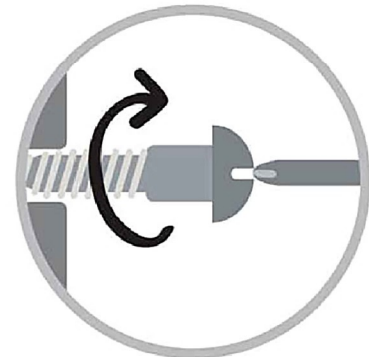

Turn clockwise to tighten and only tighten when step is completed or when instructed to do so.



Save the instructions and store any supplied tools for later maintenance.

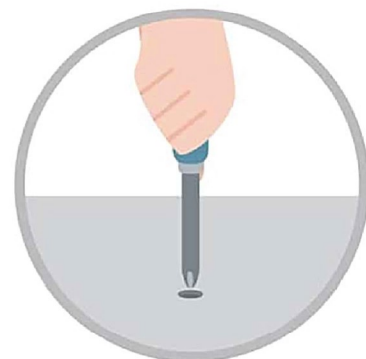

After two weeks, check and tighten any loose hardware and repeat again every six months thereafter.

IT IS THE USER'S RESPONSIBILITY TO MAINTAIN THE FURNITURE. THE HARDWARE MAY LOOSEN OVER TIME AND MAY CAUSE THE FURNITURE TO BE WOBBLY AND UNABLE TO SUPPORT ITS INTENDED WEIGHT CAPACITY. THIS MAY LEAD TO COLLAPSE AND MAY CAUSE SERIOUS INJURY.

DINING TABLE



- Please keep instructions for future reference.
- Check the quantity and irregularity of parts and hardware before you start.

PARTS

1 1pc

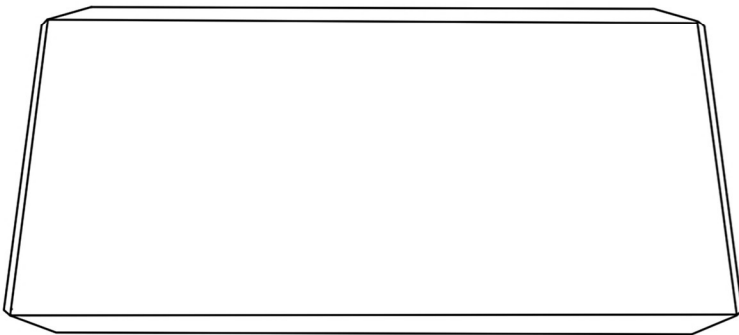

TABLE TOP

2 2pcs

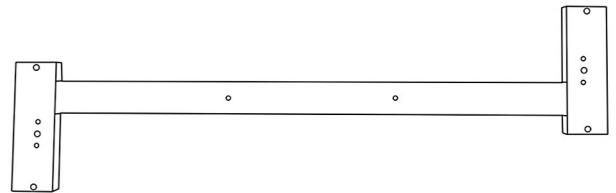

TABLE TOP SUPPORT

3 2pcs

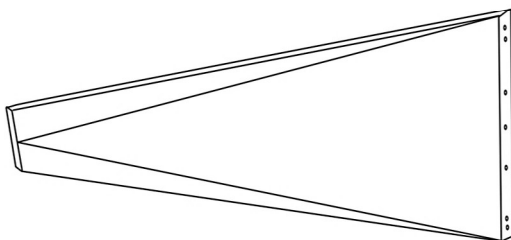

TABLE LEG - LONG

4 2pcs

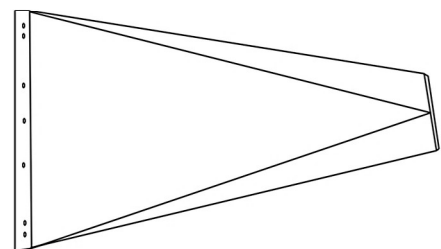
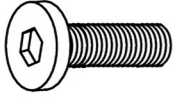

TABLE LEG - SHORT

HARDWARE

(A) 16pcs



JCBC BOLT
M6 x 30MM

(B) 16pcs



LOCK WASHER
M6

(C) 16pcs



FLAT WASHER
M6

(D) 1pc



ALLEN KEY
M4

(E) 8pcs

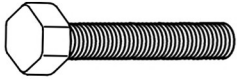

HEX BOLT
M8 x 45MM

(F) 8pcs

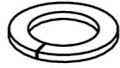

LOCK WASHER
M8

(G) 8pcs

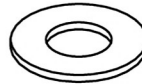

FLAT WASHER
M8

(H) 1pc



SPANNER

(I) 6pcs



WOOD DOWEL
M10 x 20MM

(J) 4pcs



WOOD DOWEL
M10 x 30MM

(K) 4pcs



CSK SCREW
M4 x 32MM

ASSEMBLY INSTRUCTIONS

1

- Part (3) x 2pcs
- Part (4) x 2pcs
- Hardware (I) x 6pcs
- Hardware (J) x 4pcs

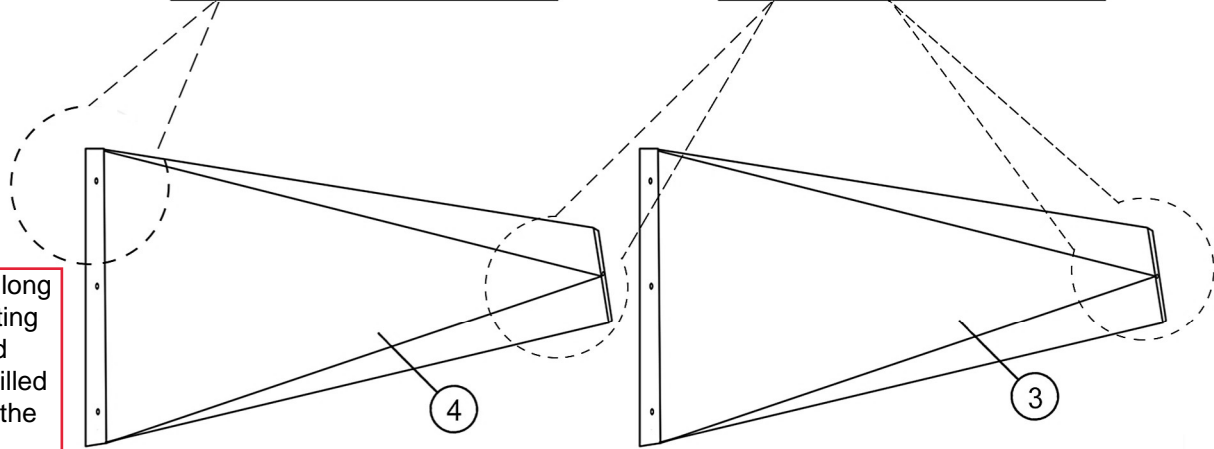
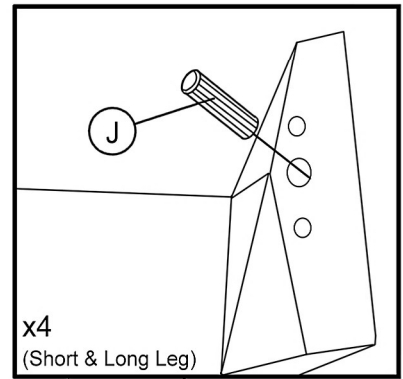
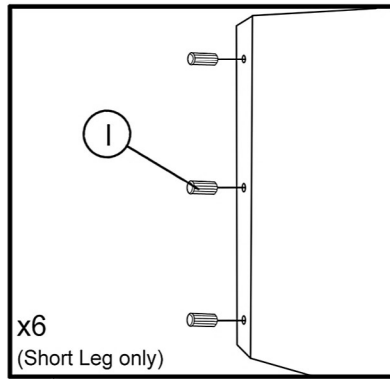

Prepare short and long table legs by inserting the dowels (#I) and (#J) into the pre-drilled holes as shown in the diagram.

2

- Part (3) x 2pcs
- Part (4) x 2pcs
- Hardware (A) x 8pcs
- Hardware (B) x 8pcs
- Hardware (C) x 8pcs
- Hardware (D) x 8pcs

Align the wide end of the long table leg (#3) to the wide end of the short table leg (#4) and using the allen key (#D) secure together with bolt (#A) with lock washer (#B) and flat washer (#C.)

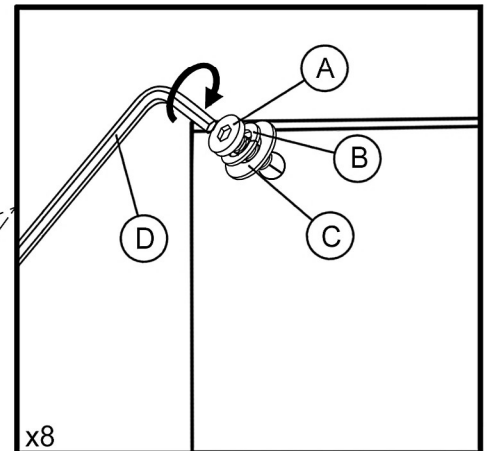
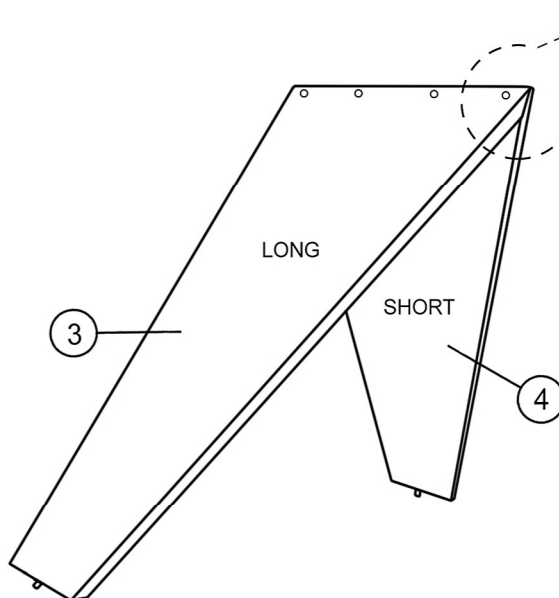

ASSEMBLY INSTRUCTIONS

3

Part (2) x 2pcs

Hardware (A) x 8pcs

Hardware (B) x 8pcs

Hardware (C) x 8pcs

Hardware (D) x 1pc

Align the table top support (#2) to the table legs and with allen key (#D) secure by using bolt (#A) with lock washer (#B) and flat washer (#C).

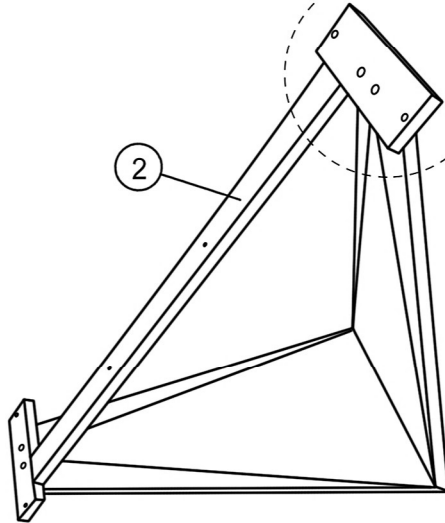
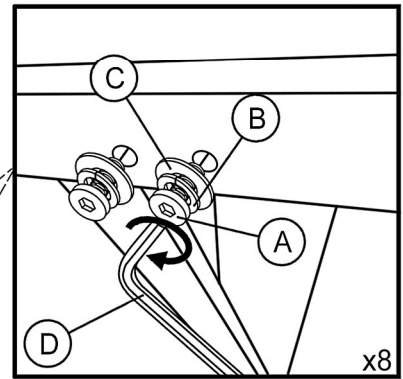

4

Part (1) x 1pc

Hardware (E) x 8pcs

Hardware (F) x 8pcs

Hardware (G) x 8pcs

Hardware (H) x 1pc

Hardware (K) x 4pcs

Align the table top support (#2) to the table top (#1) and by using spanner (#H) secure with hex bolt (#E) with lock washer (#F) and flat washer (#G). Secure at the center by using screw (#K).

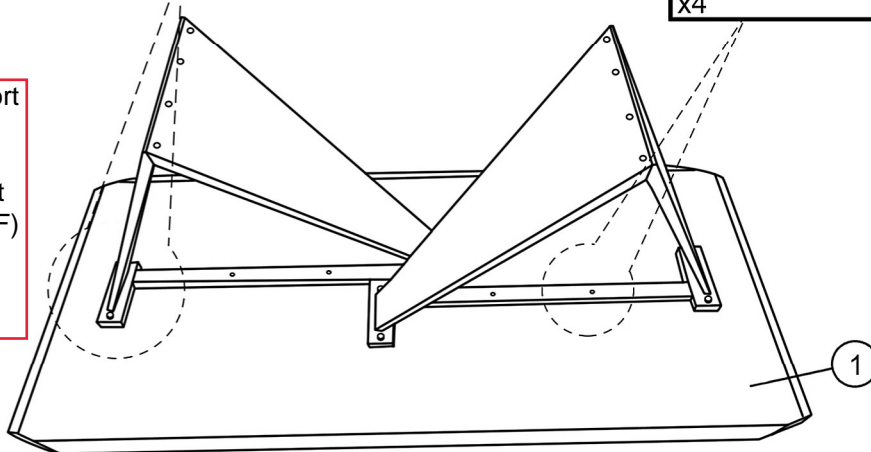
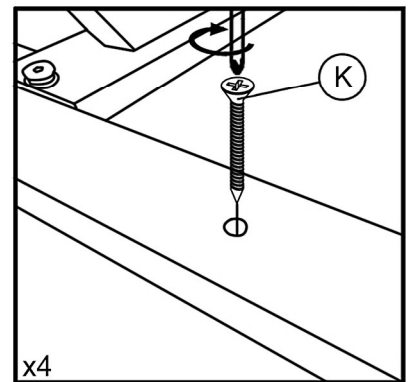
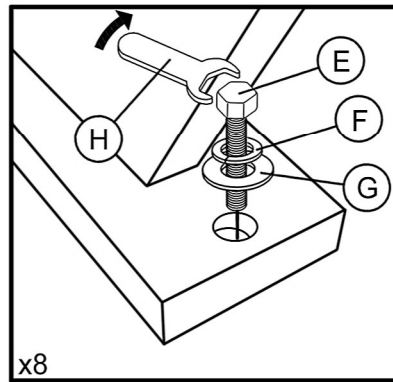

ASSEMBLY INSTRUCTIONS

5

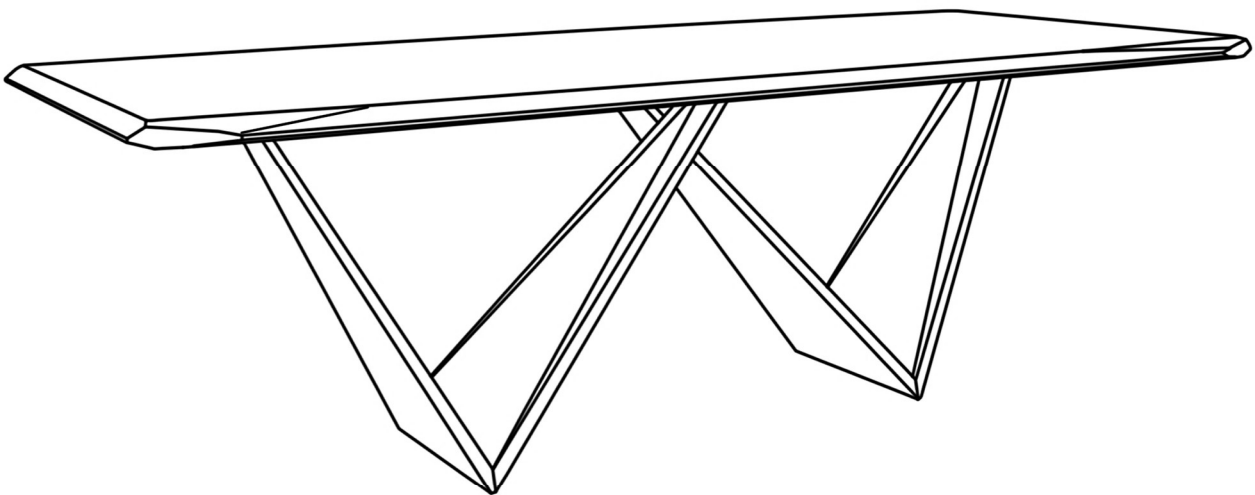

ASSEMBLY COMPLETED



Please ensure the furniture rests on an even and flat surface. If the product wobbles or feels loose, double-check all bolts and/or screws are properly tightened and secured.



Keep this handy!

Please retain this instruction manual and any order-related information for future reference.



Lift, don't drag!

To avoid damage to product please always LIFT the product when transporting or adjusting the placement.

This product is intended for RESIDENTIAL USE ONLY and not for commercial use.

ASSEMBLY INSTRUCTIONS

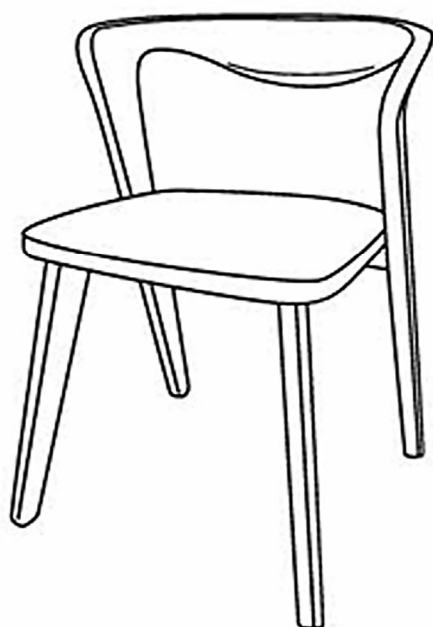

TOOLS REQUIRED



Screwdriver
(Not Included)

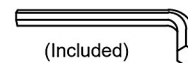

(Included)
Allen Wrench



2 - People

ASSEMBLY RATING



EASY ————— DIFFICULT

The Assembly Rating is a 5-point system showing the level of effort needed to assemble a specific product.



CHECK BEFORE STARTING

Are you missing anything?

Double-check all parts, hardware and accessories listed are all accounted for.

Check out our Quick Tips!

We recommend reviewing the pre-assembly handouts. Even experts need a refresher now and then!

Should we send any replacements?

Are there any irregularities or flaws in the parts? We can send replacements!

Prep Time!

Please review the assembly instructions and all diagrams prior to assembling.

PRE ASSEMBLY INTRODUCTION

We understand building ready-to-assemble furniture can be a challenging experience for some. To help avoid confusion, we have provided some helpful tips that may speed up the process.



Teamwork

ALWAYS have at least two people to help with transporting and assembling the product to avoid potential injury and/or damage.

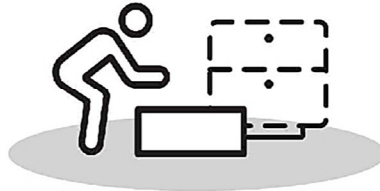
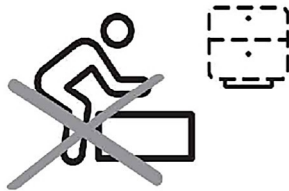

Suitable Location

Assembling near the area of the intended location is highly recommended.



Sufficient Space

Make sure you have enough space to move around during the assembly.



Avoid Scratches

Use cardboard, blankets or a carpeted area while assembling furniture to prevent to prevent scratches and damages.

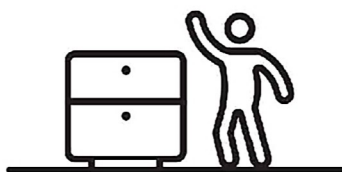
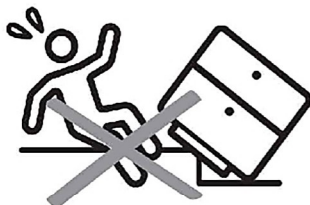

Flat Surface

Make sure the furniture rests on a flat and level surface with each leg evenly touching the floor.

ASSEMBLY AND CARE ADVICE



FAILURE TO FOLLOW THE GUIDELINES BELOW MAY RESULT IN INJURY AND/OR PROPERTY DAMAGE.



Position each part correctly and insert screws or bolts into their respective holes.



Use the appropriate hand tools or power tools for assembly. Select steps, such as tightening screws and/or bolts, may require hand tools to avoid causing damage during assembly.

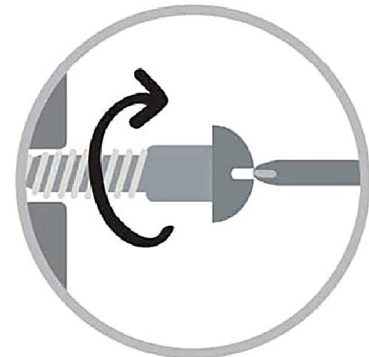

Turn clockwise to tighten and only tighten when step is completed or when instructed to do so.



Save the instructions and store any supplied tools for later maintenance.

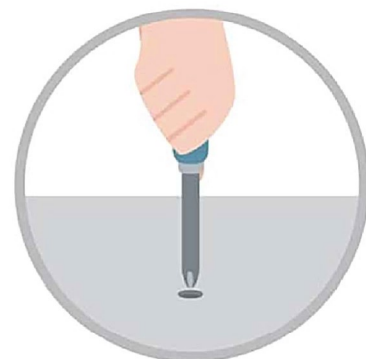

After two weeks, check and tighten any loose hardware and repeat again every six months thereafter.

IT IS THE USER'S RESPONSIBILITY TO MAINTAIN THE FURNITURE. THE HARDWARE MAY LOOSEN OVER TIME AND MAY CAUSE THE FURNITURE TO BE WOBBLY AND UNABLE TO SUPPORT ITS INTENDED WEIGHT CAPACITY. THIS MAY LEAD TO COLLAPSE AND MAY CAUSE SERIOUS INJURY.

DINING SIDE CHAIR



- Please keep instructions for future reference.
- Check the quantity and irregularity of parts and hardware before you start.

PARTS

1 1pc

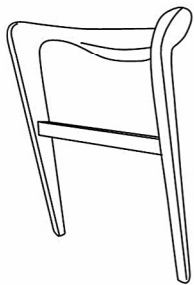

BACK PANEL

2 1pc

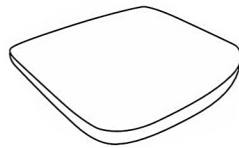

WOODEN SEAT

3 1pc



FRONT LEG - LEFT

4 1pc



FRONT LEG - RIGHT

HARDWARE

A 8pcs

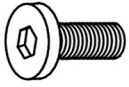

JCBC BOLT
M6 x 20MM

B 4pcs

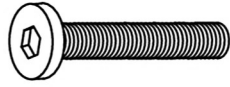

JCBC BOLT
M6 x 50MM

C 12pcs



LOCK WASHER
M6

D 4pcs

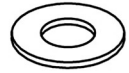

FLAT WASHER
M6

E 1pc



ALLEN KEY
M4

ASSEMBLY INSTRUCTIONS

Attach the left/right front leg (#3) and (#4) to the cushion seat (#2) with allen key (#E) and by using bolt (#A) with lock washer (#C).

1

- Part ② x 1pc
- Part ③ x 1pc
- Part ④ x 1pc
- Hardware ① x 8pcs
- Hardware ② x 8pcs
- Hardware ③ x 1pc

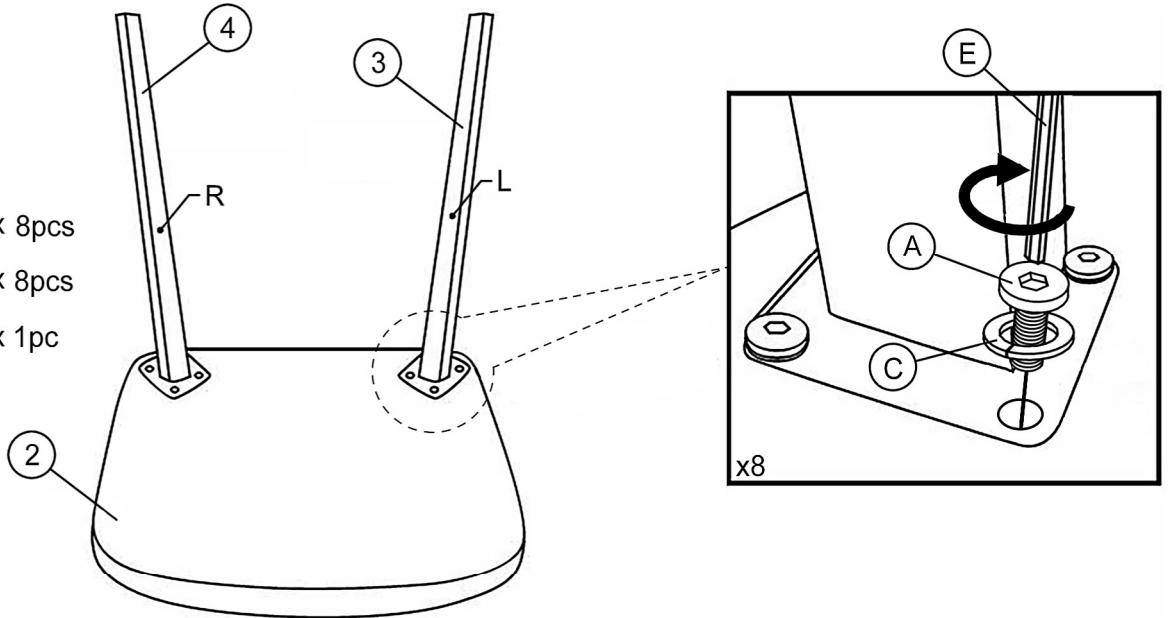

2

Align and attach the back panel (#1) to the cushion seat (#2) with allen key (#E) secure by using bolt (#B) with lock washer (#C) and flat washer (#D).

- Part ① x 1pc
- Hardware ① x 4pcs
- Hardware ② x 4pcs
- Hardware ③ x 4pcs
- Hardware ④ x 1pc

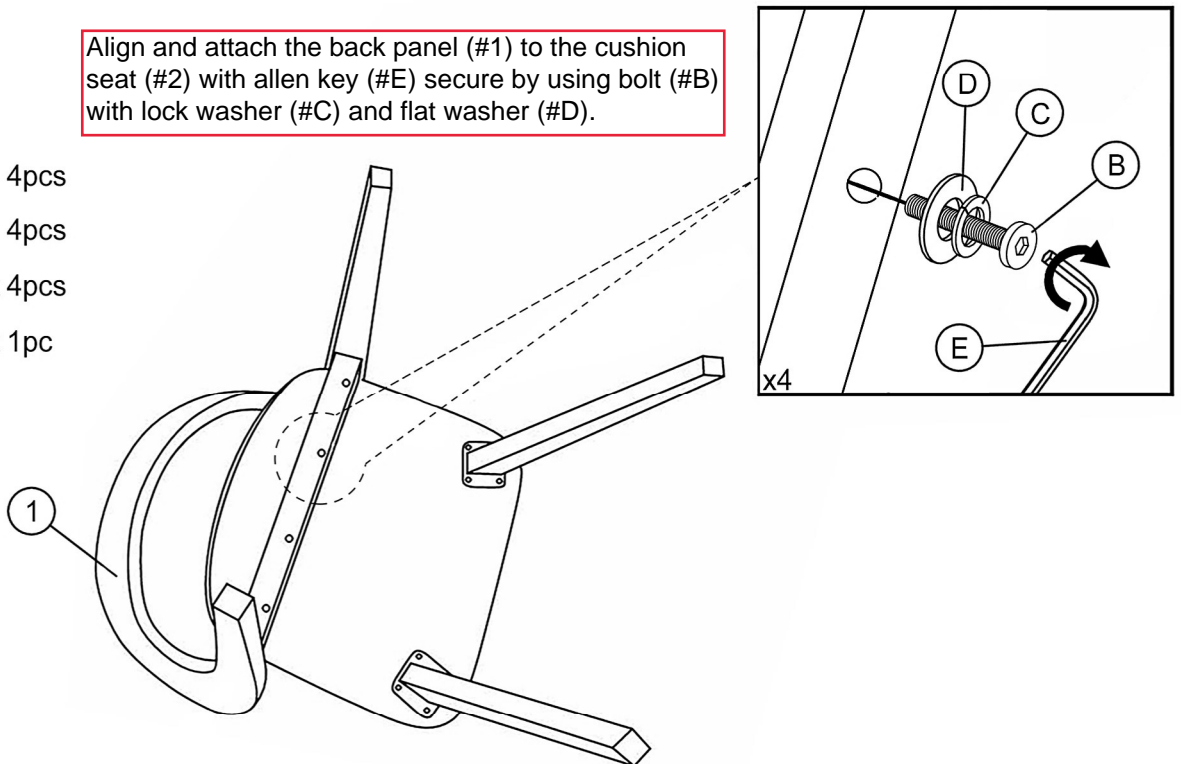

ASSEMBLY INSTRUCTIONS

3

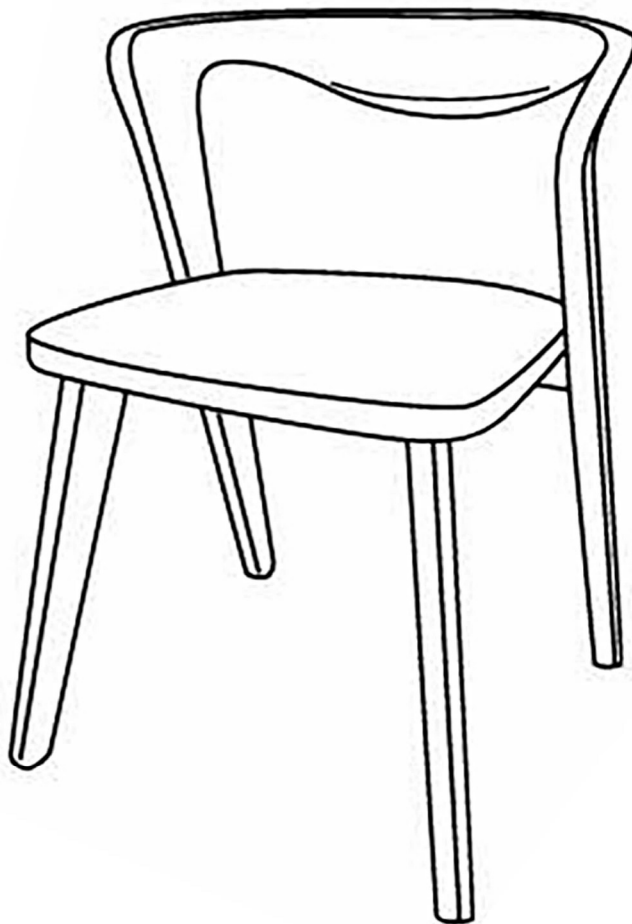

ASSEMBLY COMPLETED



Please ensure the furniture rests on an even and flat surface. If the product wobbles or feels loose, double-check all bolts and/or screws are properly tightened and secured.



Keep this handy!

Please retain this instruction manual and any order-related information for future reference.



Lift, don't drag!

To avoid damage to product please always LIFT the product when transporting or adjusting the placement.

This product is intended for RESIDENTIAL USE ONLY and not for commercial use.