

# Assembly Instructions

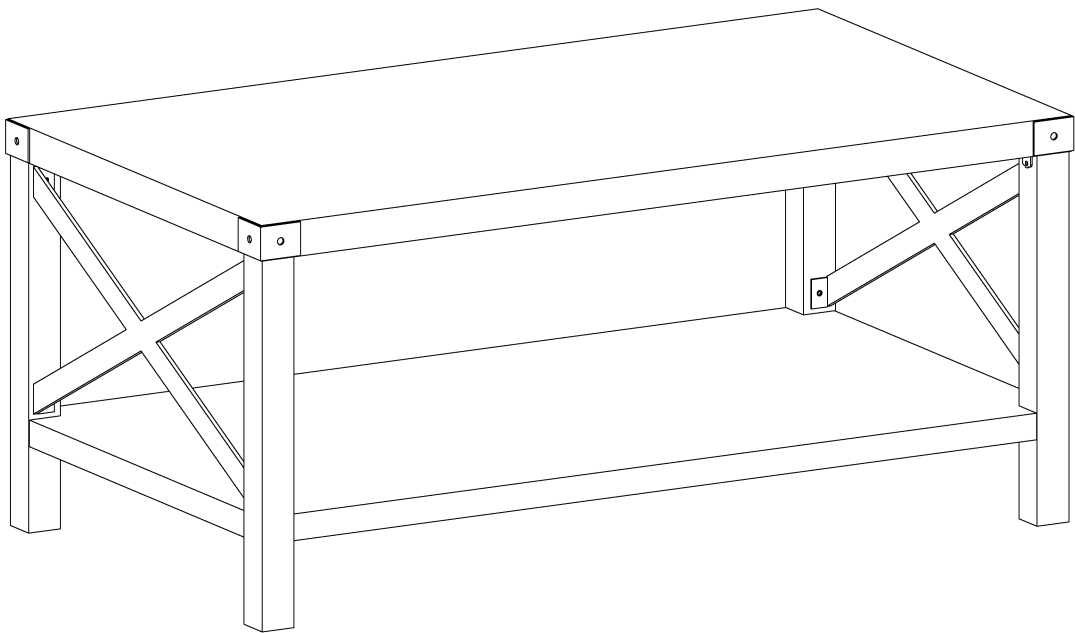

# General Assembly Guidelines

- I. Ensure that all parts and hardware are available before beginning assembly.
- II. Follow each step carefully to ensure the proper assembly of this product.
- III. Two people are recommended for ease in the assembly of this product.
- IV. The three main types of hardware used to assemble this product are : wood dowels , screws and bolts.
- V. The provided glue is to secure wood dowels in place . When first inserting dowels , locate the appropriate hole for the dowel , place a small amount of glue in the hole and insert the dowel . Wipe away excess glue immediately.

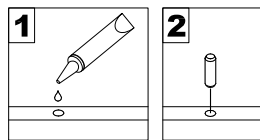

In future assembly steps when dowels are necessary to attach assembly parts together , place a small amount of glue on the end of the dowel before attaching parts together . Wipe away excess glue immediately.

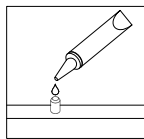

- VI. A Phillips head screwdriver is required for the assembly of this product .

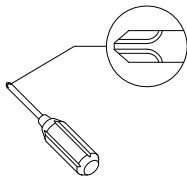



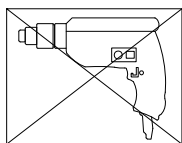



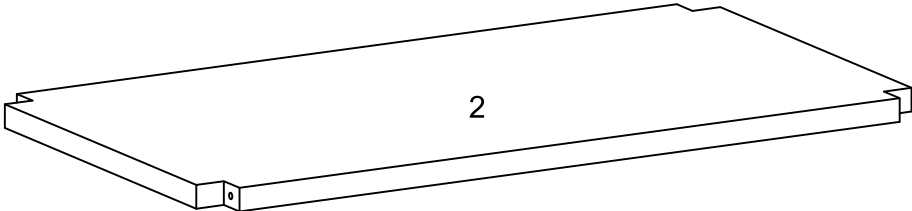
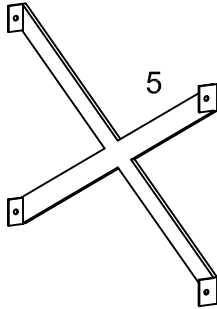
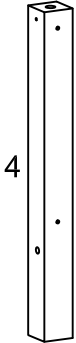
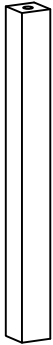
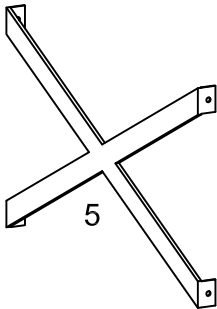
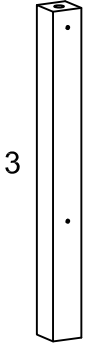
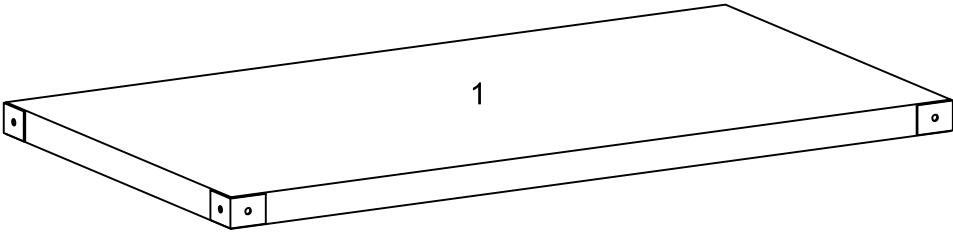

- VII. Power tools should not be used to assemble this product .

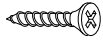

# Parts List

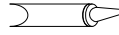

# Hardware List

A		Ø12x40mm	Wooden dowel	4 pcs
B		Ø5x12	Screw	8 pcs
C		Ø3x15	Screw	8 pcs
D			Bracket	4 pcs
E		Ø8x60mm	Bolt	4 pcs
F		Ø5/16	Washer	4 pcs
G		Ø5/16	Nut	4 pcs
H		Ø5/16	Wrench	1 pcs
J		Ø38mm	Sticker	4 pcs
K			Glue tube	1 pcs

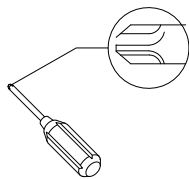

Philips head screwdriver required for assembly  
(not included)

*The hardware quantities listed above are required for proper assembly.  
Some extra hardware may also have been included.*

# Step 1

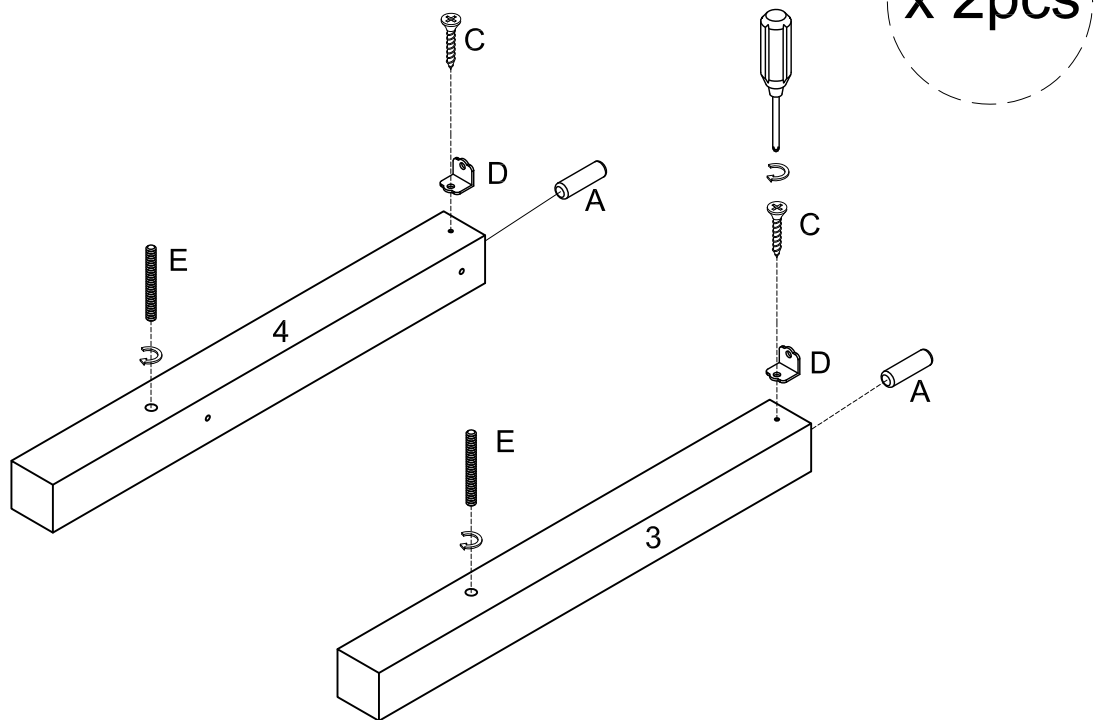

Insert wooden dowel (A) and bolt (E) into part (3,4). Attach bracket (D) to part (3,4) using screw (C) with screwdriver. Repeat this step.

# Step 2

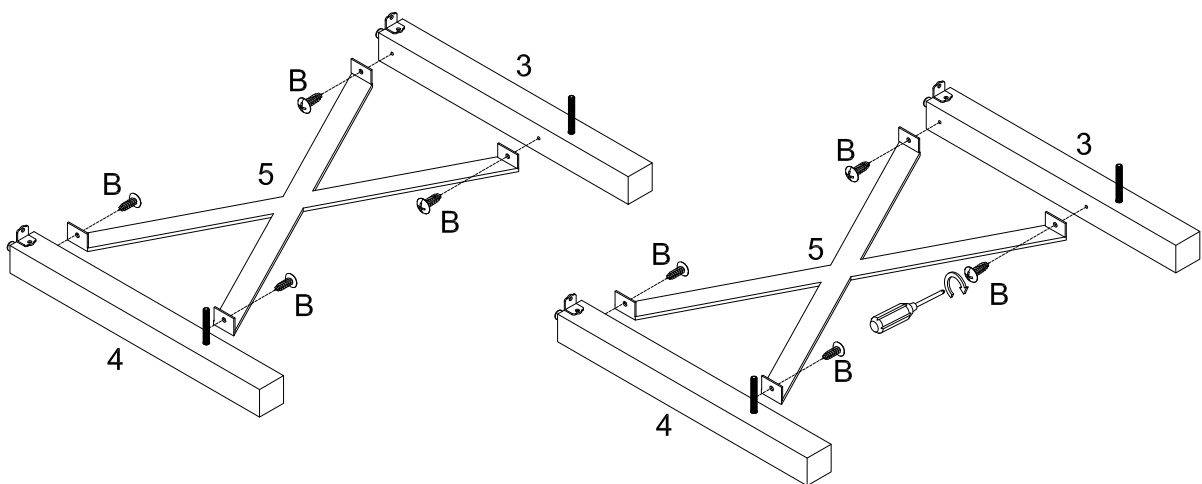

Attach part (3,4) to part (5) using screw (B) with screwdriver.

## Step 3

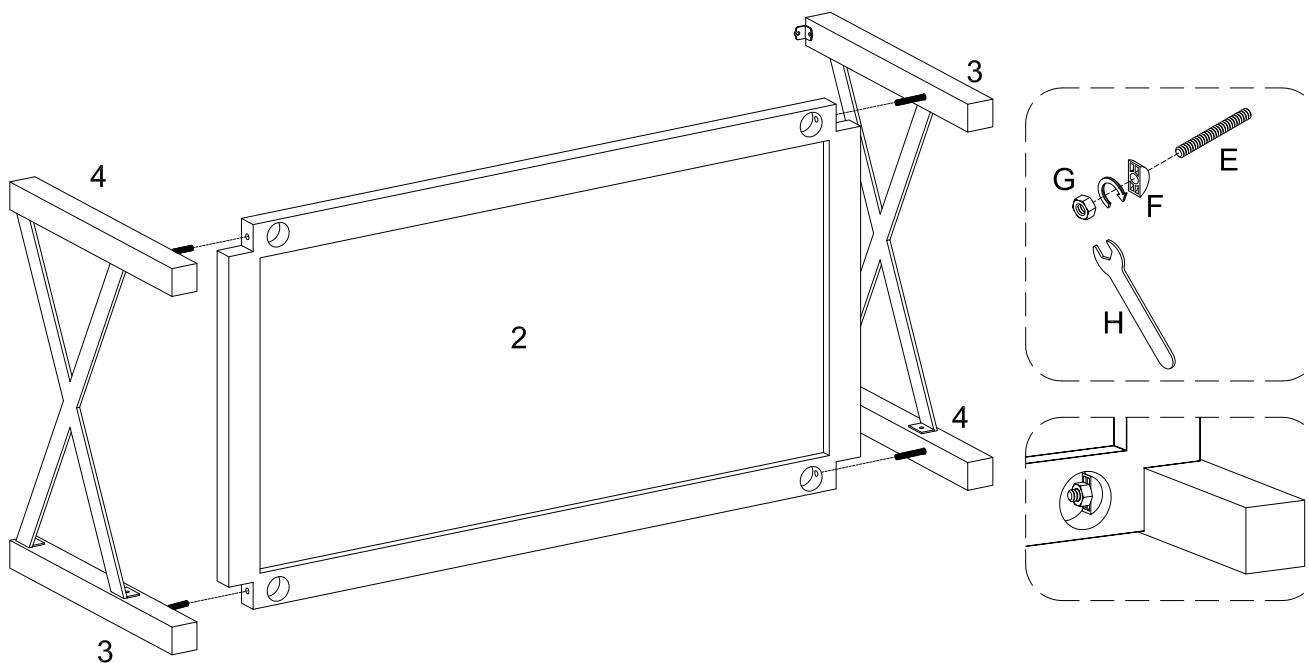

Attach part (3,4) to part (2) using nut (G), washer (F), and bolt (E) with wrench (H).

## Step 4

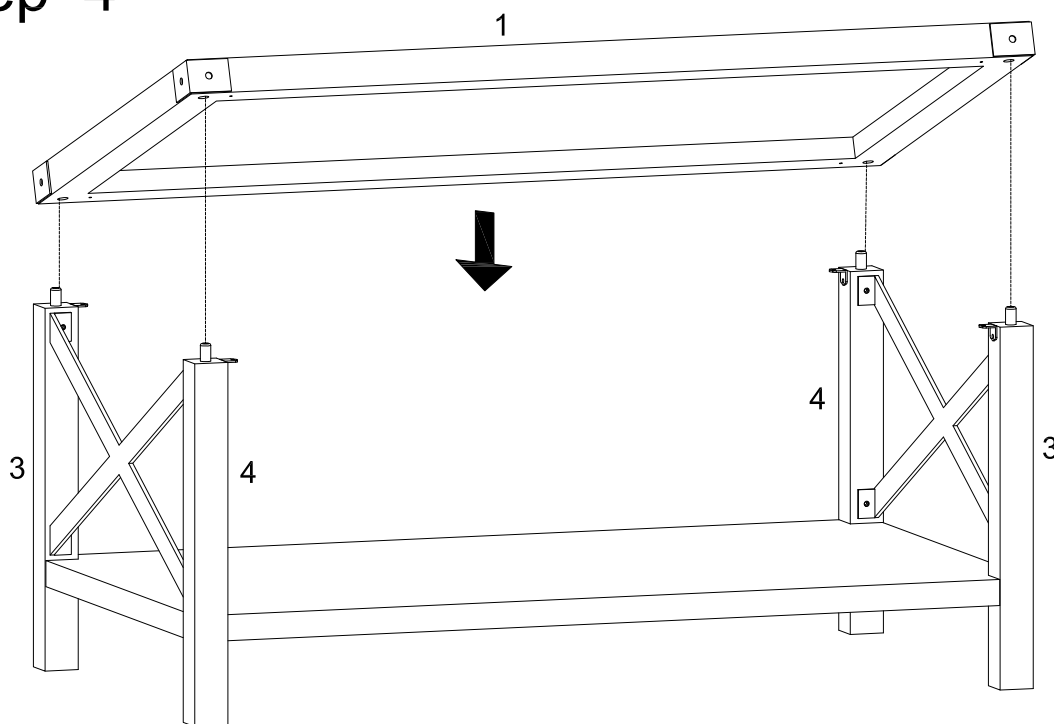

Attach part (1) to part (3,4).

## Step 5

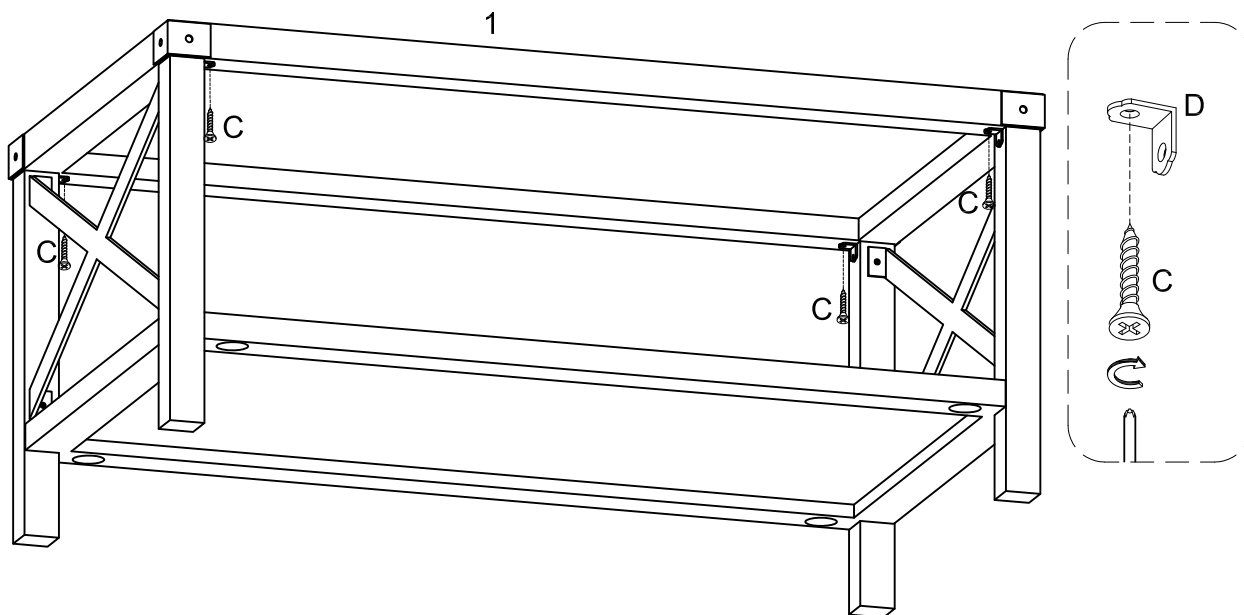

Secure part (1) using screw (C) with screwdriver through bracket (D).

## Step 6

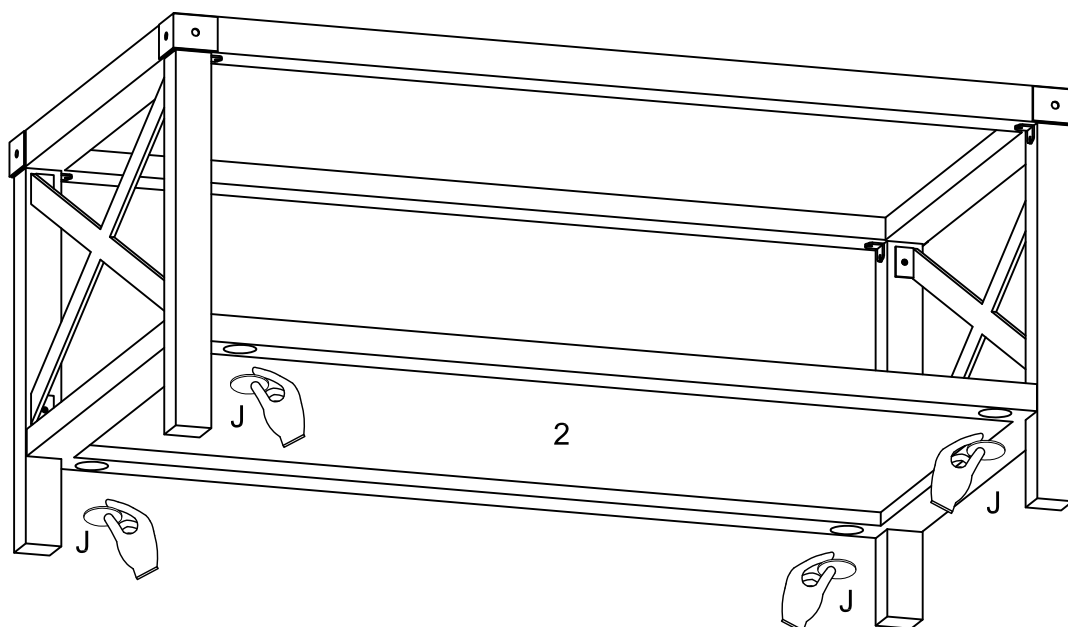

Place sticker (J) over holes as per diagram.

# Step 7

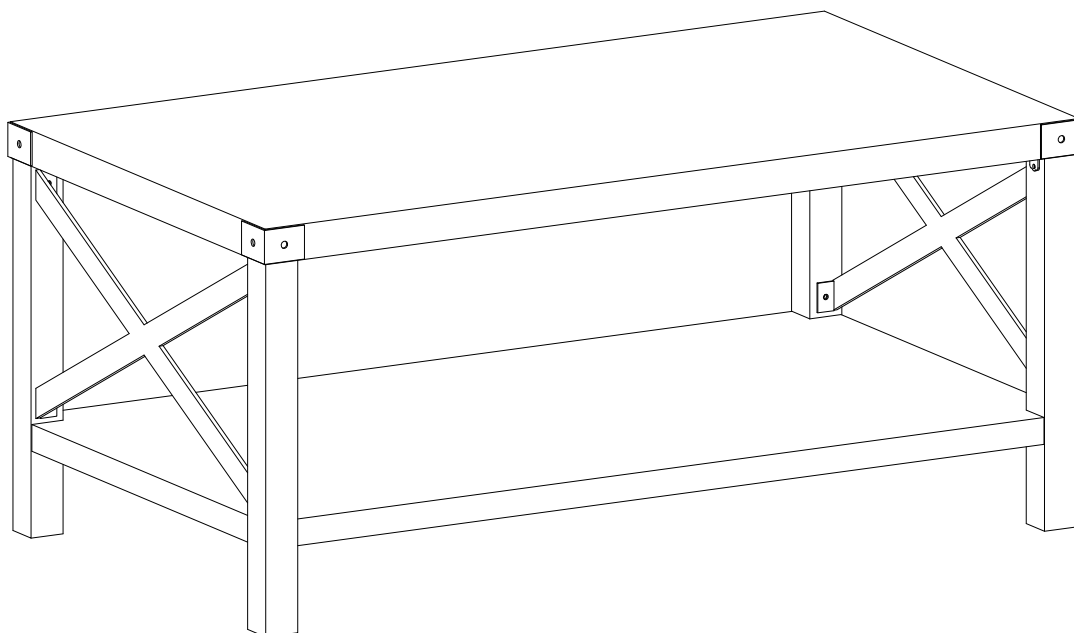

Final Assembly