

1870000652A2

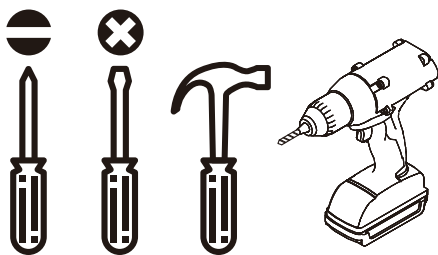

Tools required
(not included)

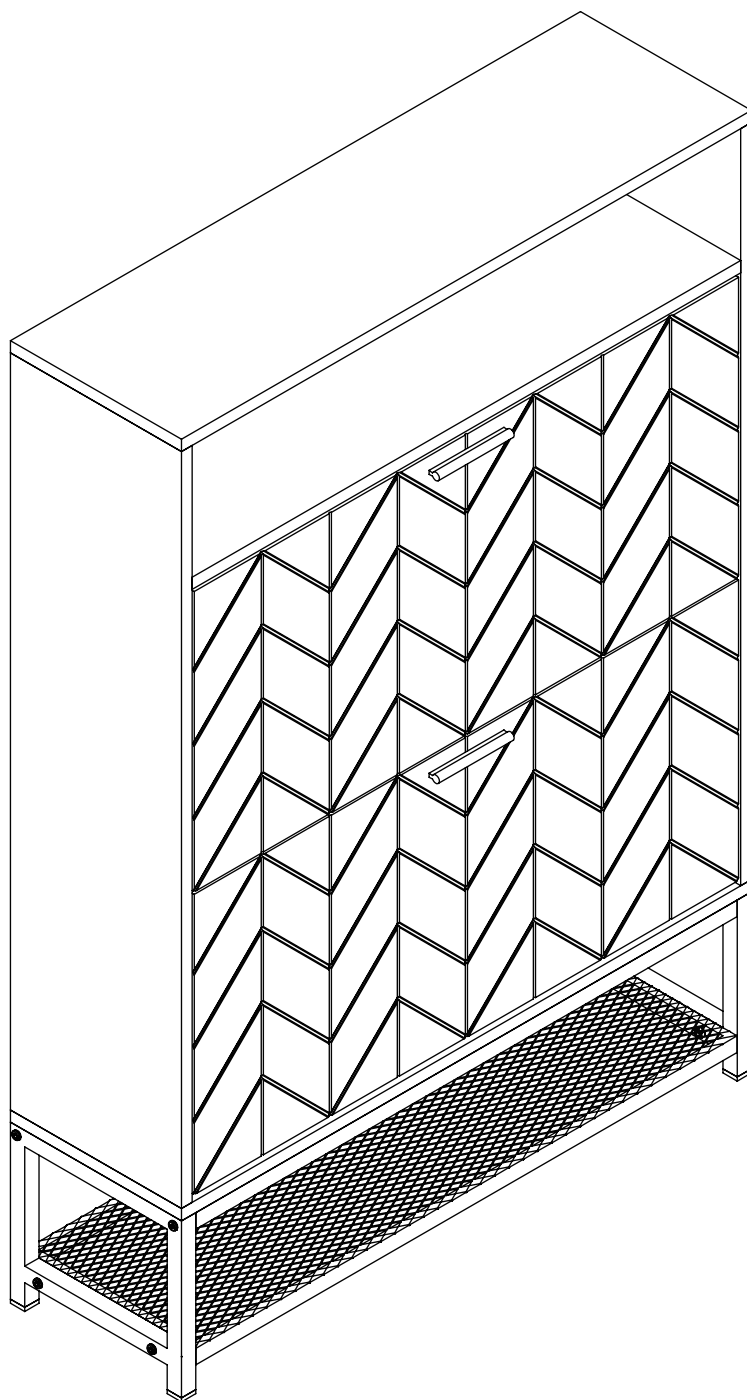

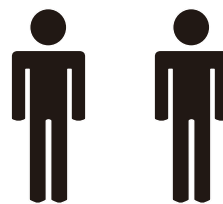



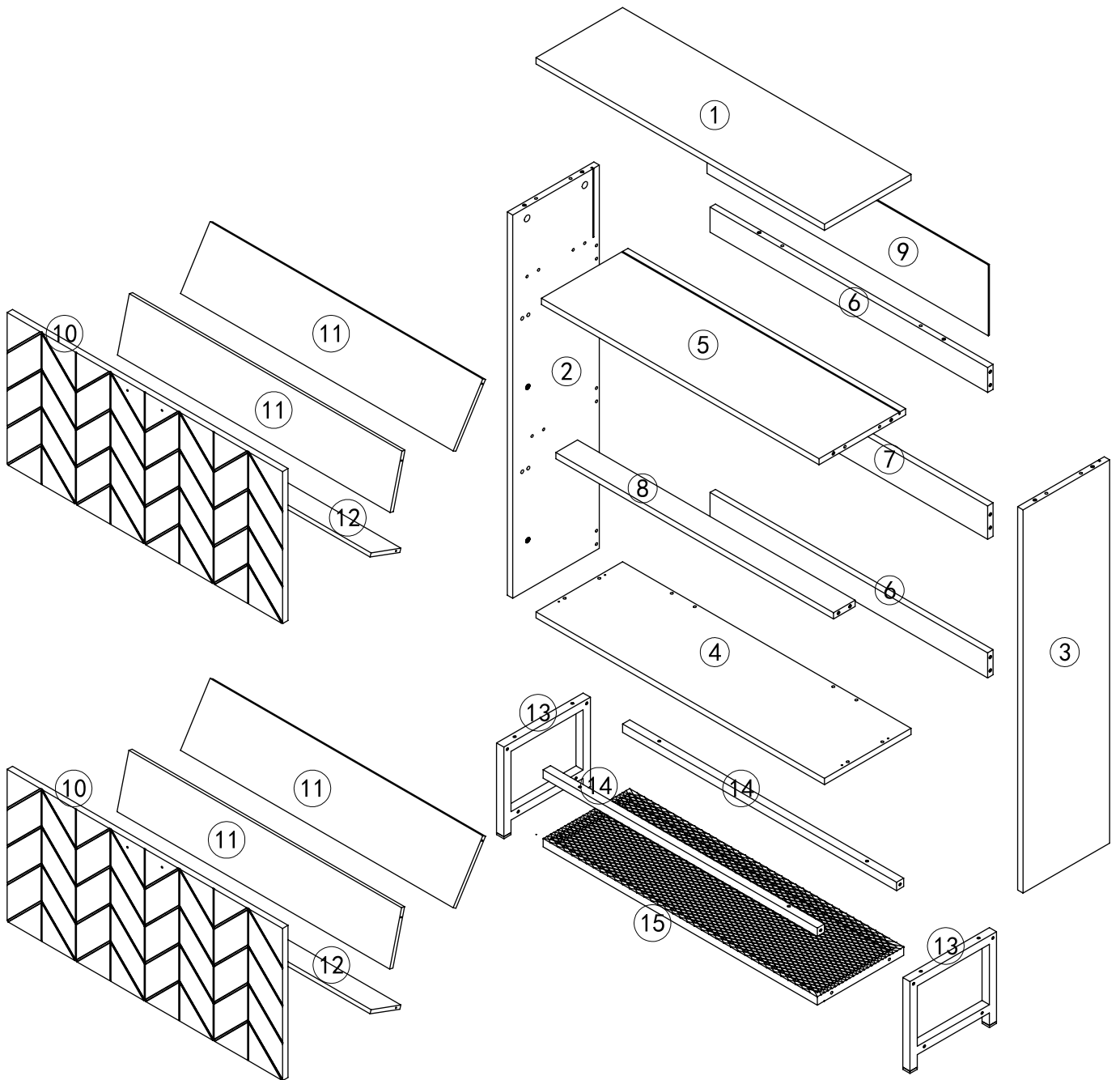













2 people for assembly

PRODUCT ASSEMBLY

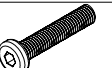



Hardware List

A		28 pcs	G		8 pcs	M		8 pcs
B		28 pcs	H		4 pcs	N		2 pcs
C		16 pcs	I		4 pcs	O		4 pcs
D		4 pcs	J		2 pcs	P		2 pcs
E		24 pcs	K		2 pcs	Q		2 pcs
F		16 pcs	L		4 pcs	R		1 sets
						S		4 pcs

PRODUCT ASSEMBLY

Step 1

F		4 pcs
R		1 pcs

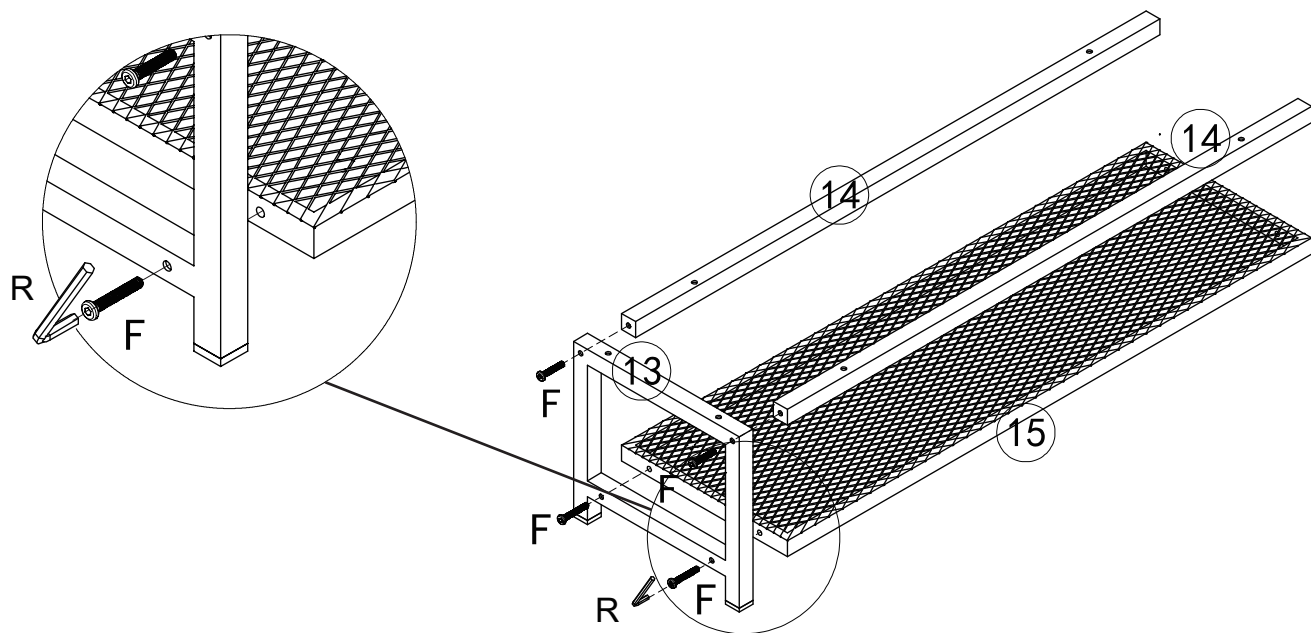

Step 2

F		4 pcs
---	---	-------

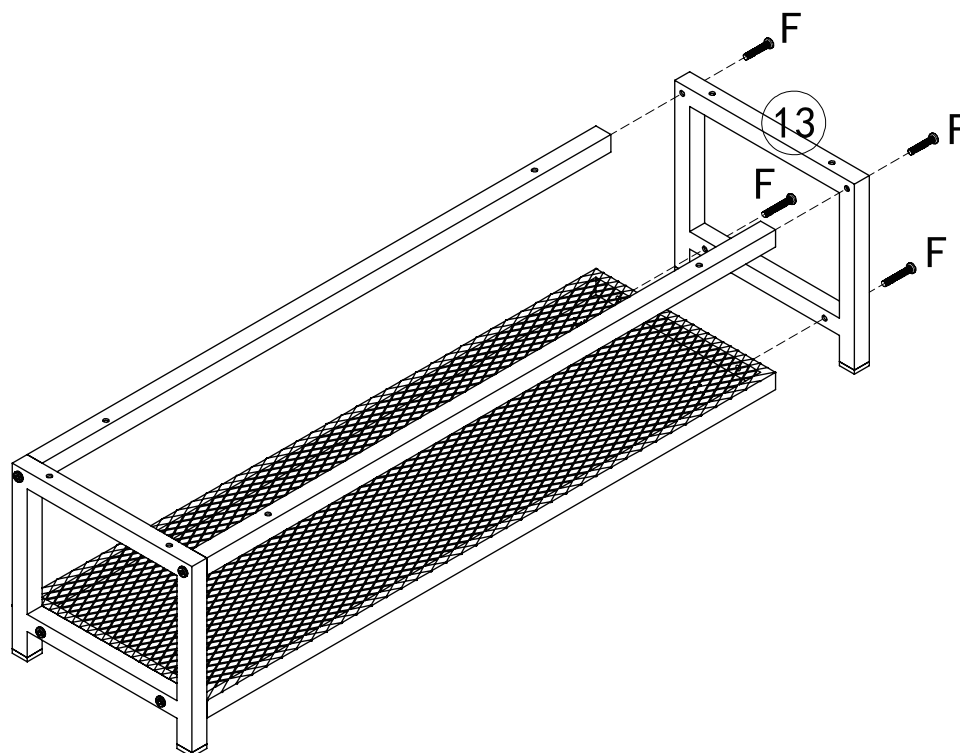

PRODUCT ASSEMBLY

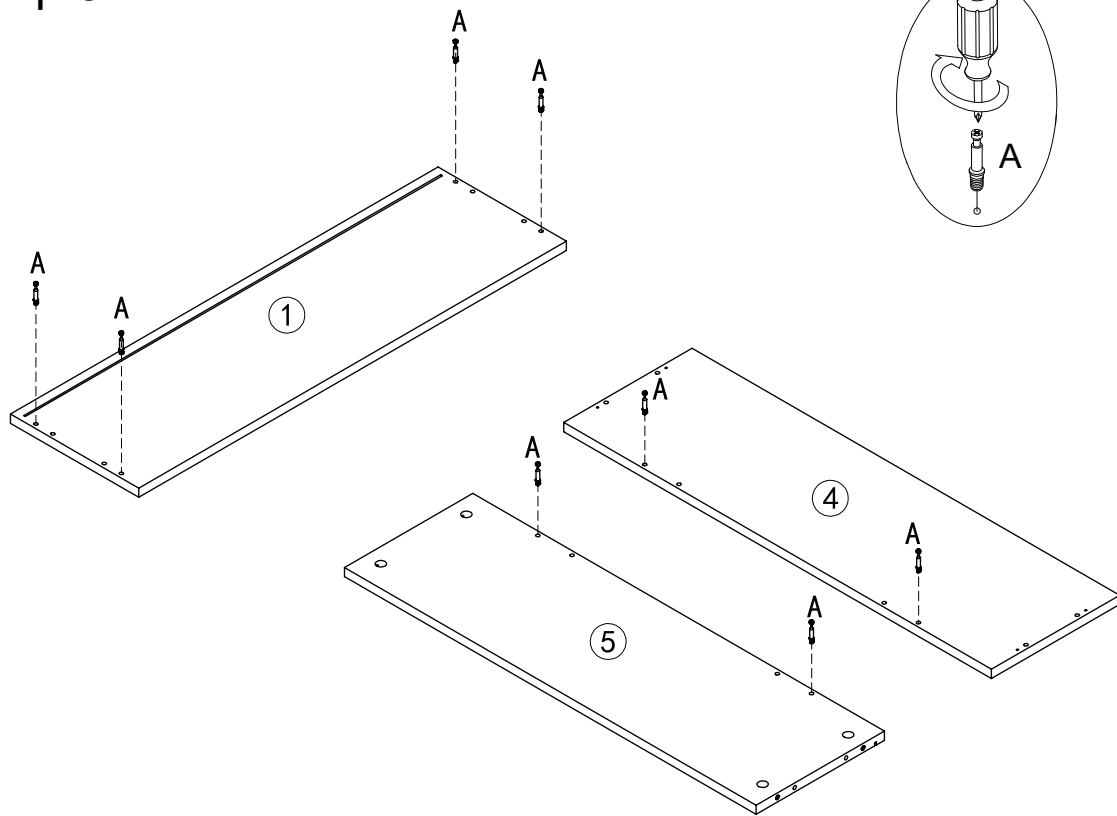

Step 3

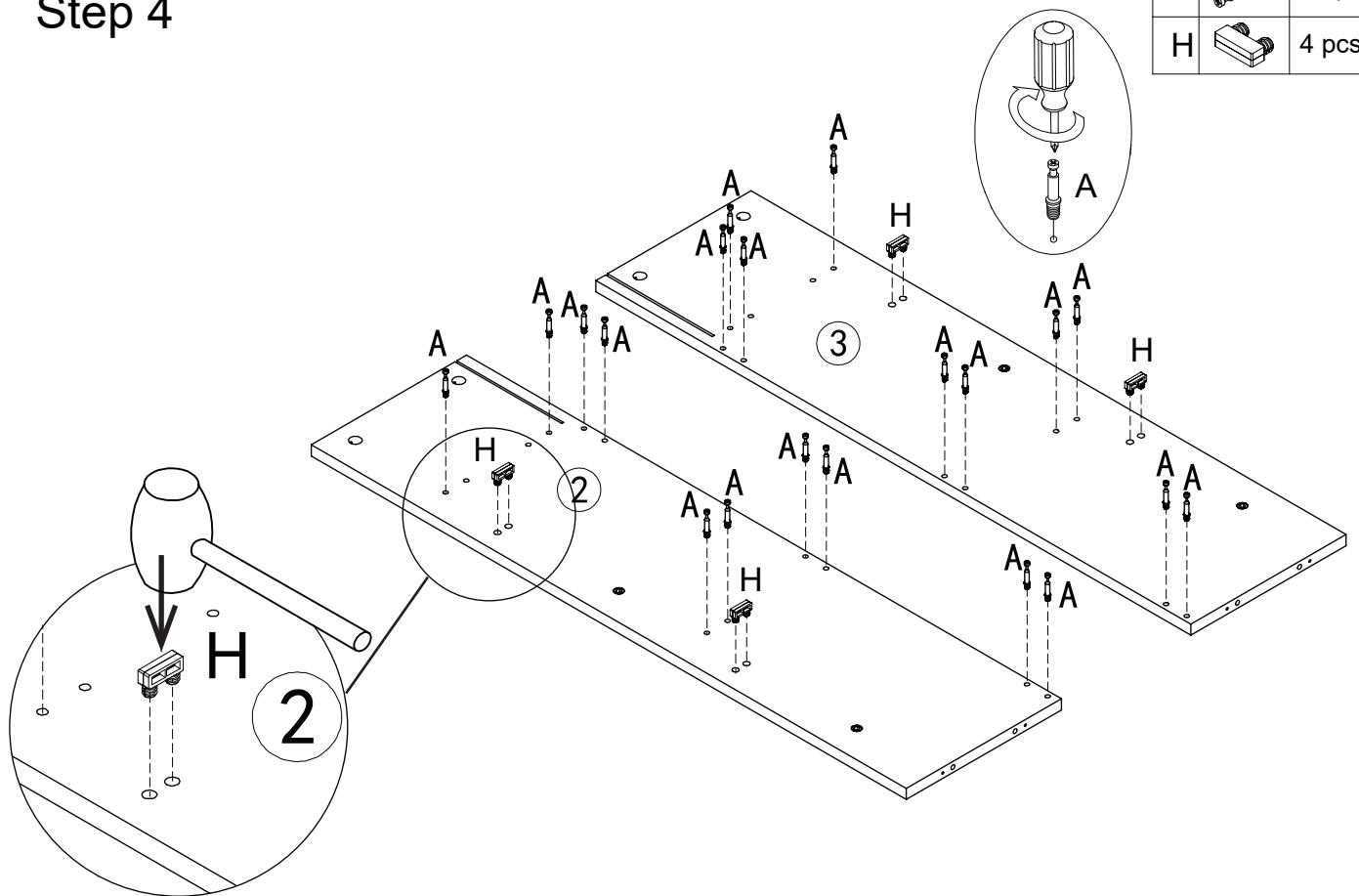

A		8 pcs
---	---	-------

Step 4



A		20 pcs
H		4 pcs



PRODUCT ASSEMBLY

Step 5

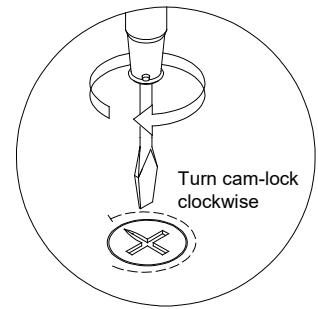
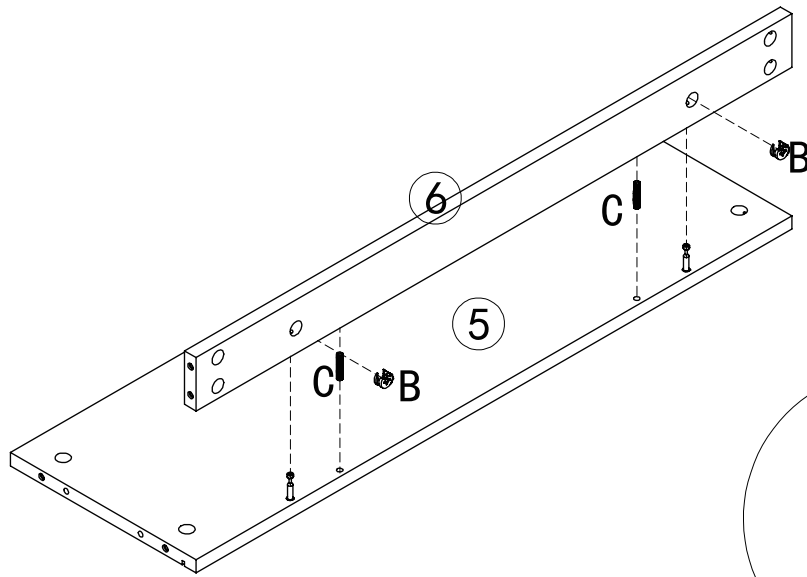
B		2 pcs
C		2 pcs



Step 6

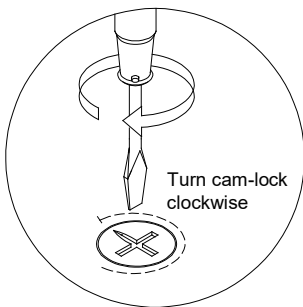
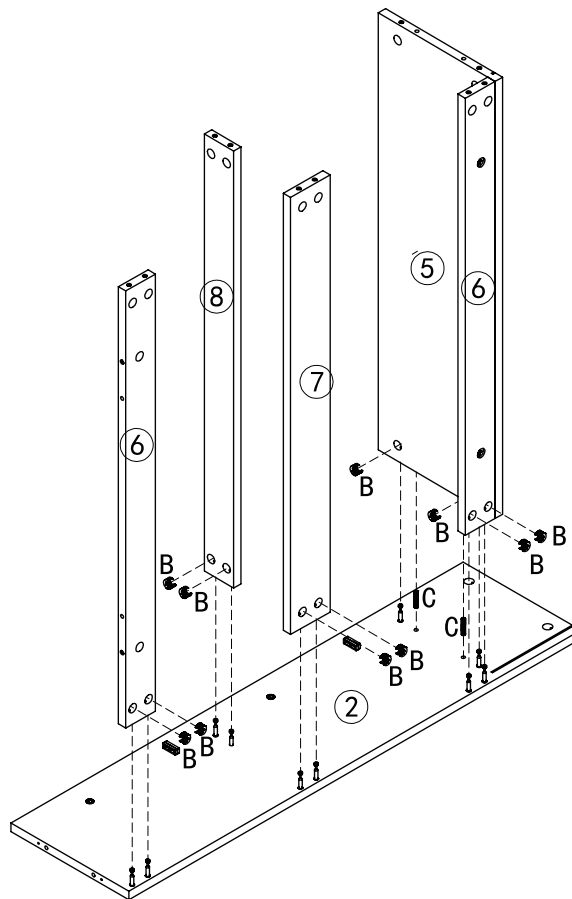

B		10 pcs
C		2 pcs

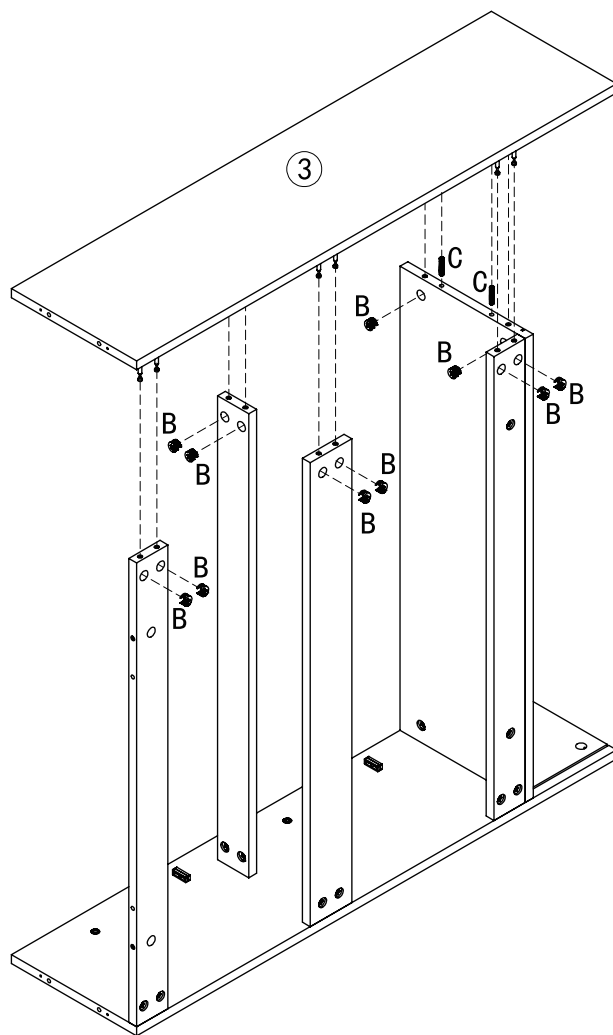

PRODUCT ASSEMBLY

Step 7



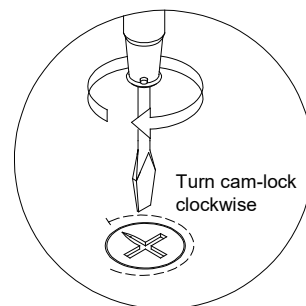

B		10 pcs
C		2 pcs

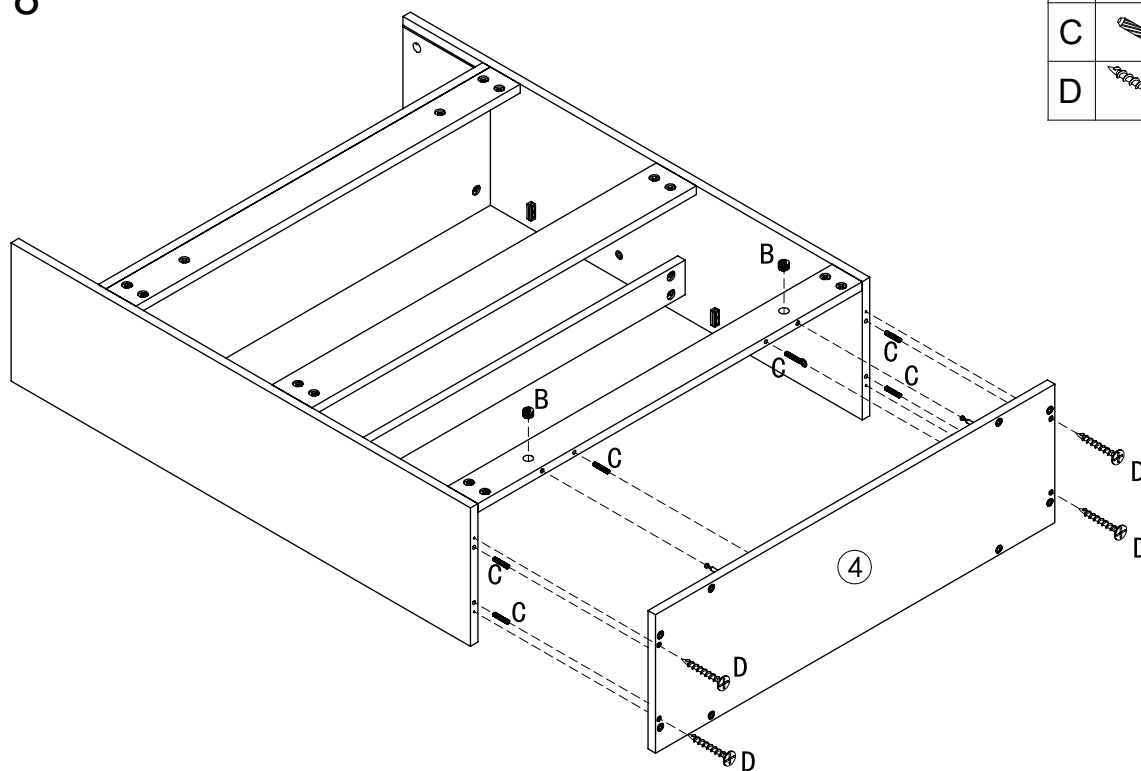

Step 8



B		2 pcs
C		6 pcs
D		4 pcs

PRODUCT ASSEMBLY

Step 9

F  8 pcs

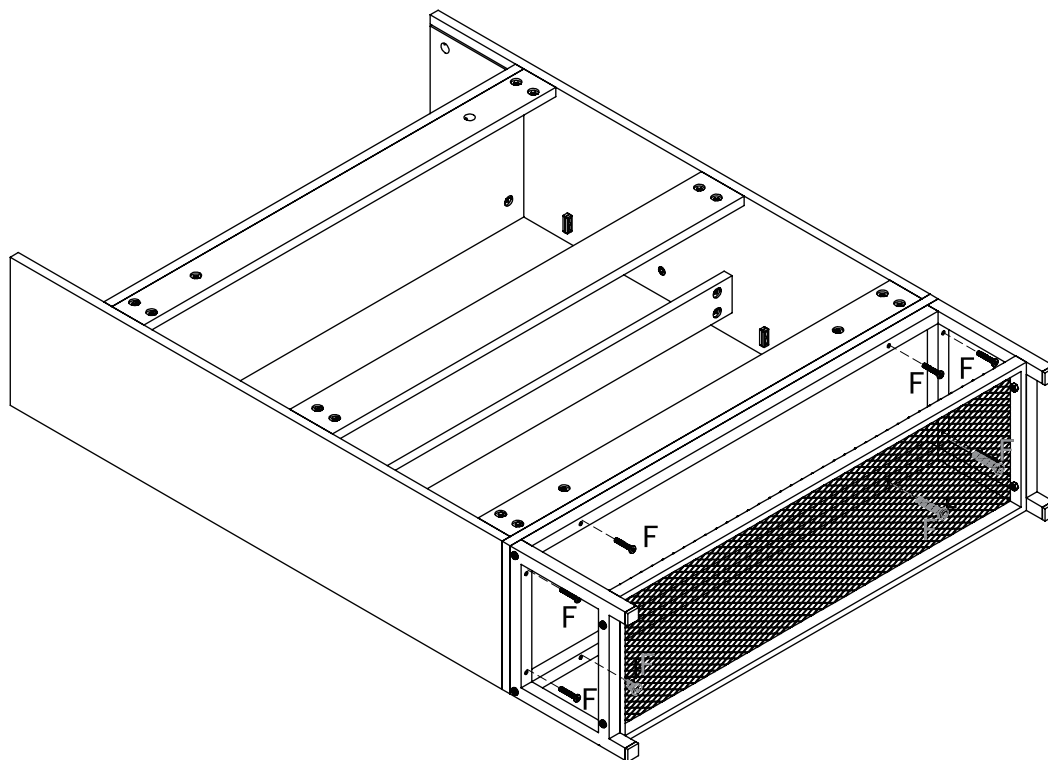

Step 10

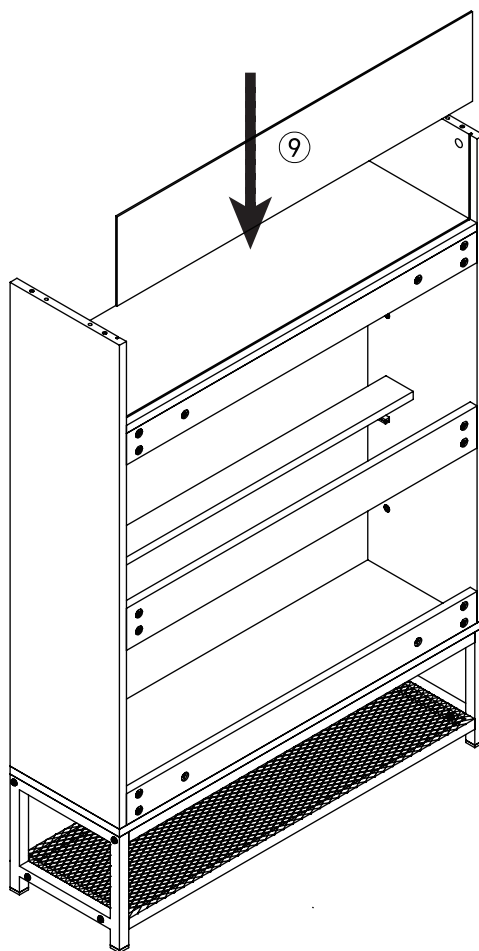

PRODUCT ASSEMBLY

Step 11

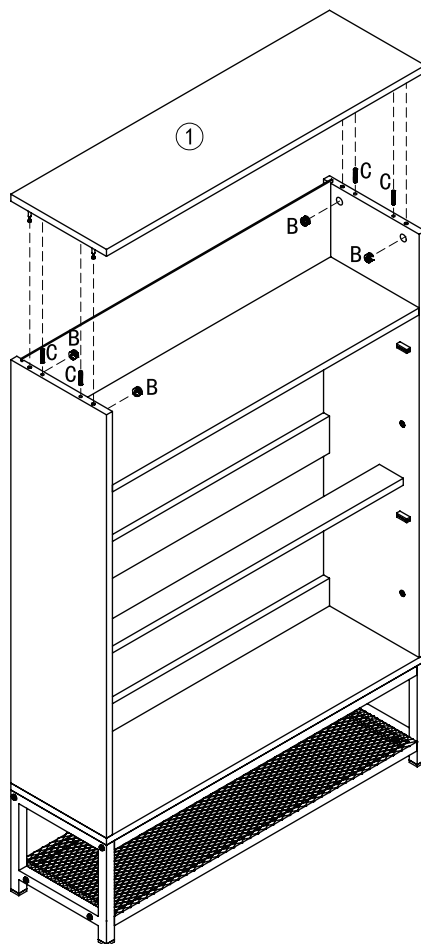

B		4 pcs
C		4 pcs

Step 12

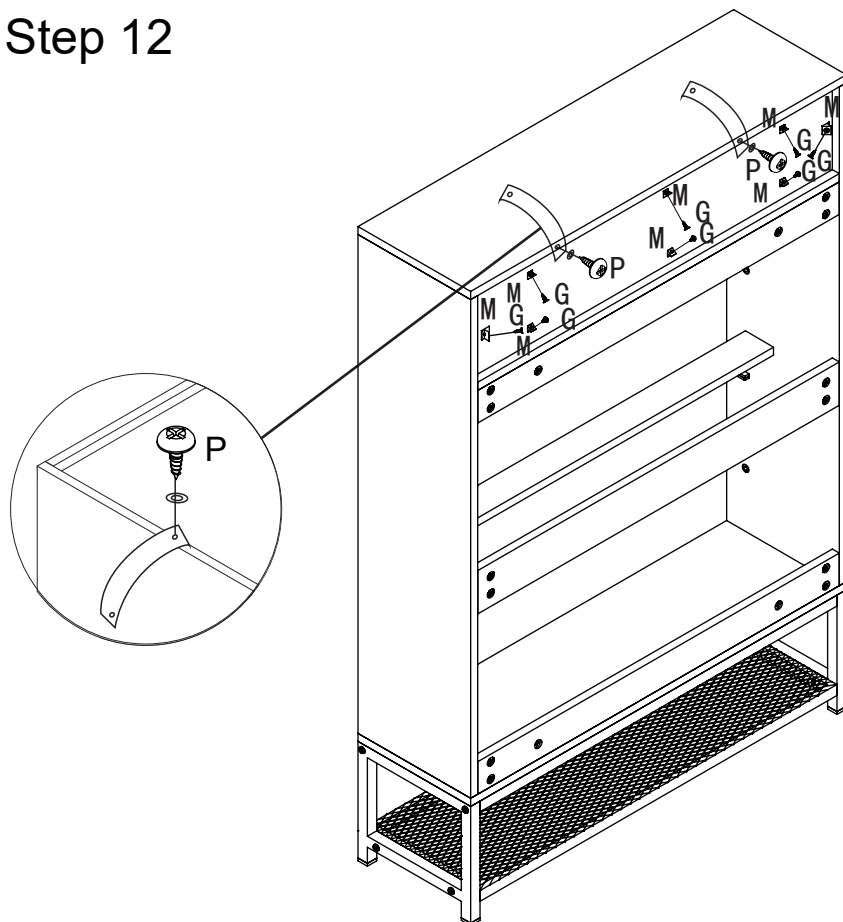

G		8 pcs
M		8 pcs
P		2 pcs

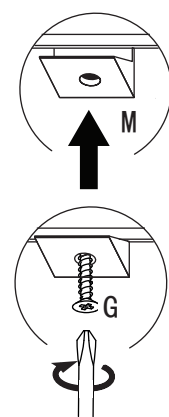

Optional: These plastic triangles help hold the back panel in place. The tabs on the buckles slide between the back panel and the thicker wood.

PRODUCT ASSEMBLY

Step 13

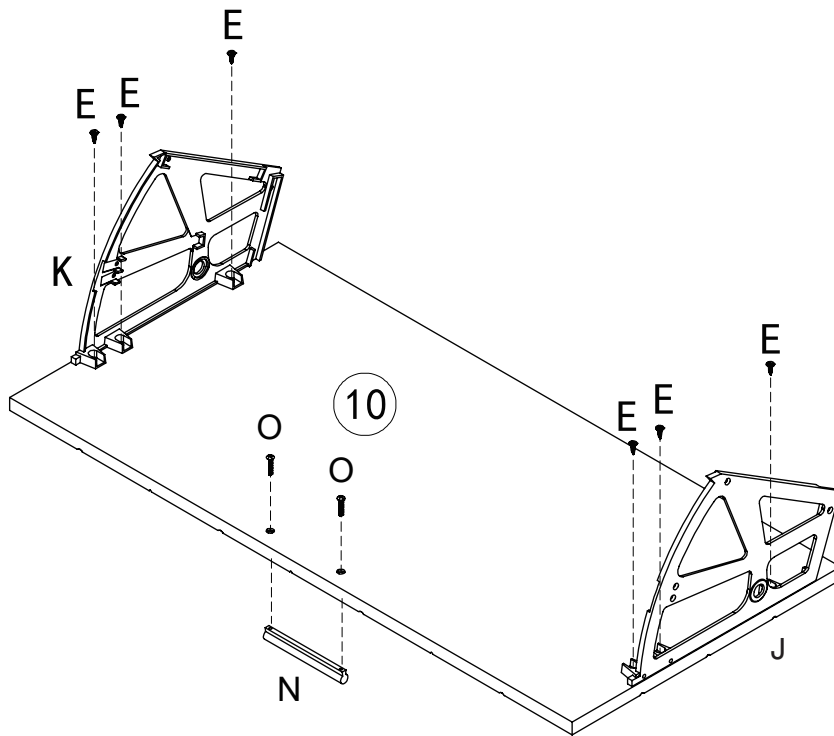

X2

E		12 pcs
J		2 pcs
K		2 pcs
N		2 pcs
O		4 pcs

Step 14

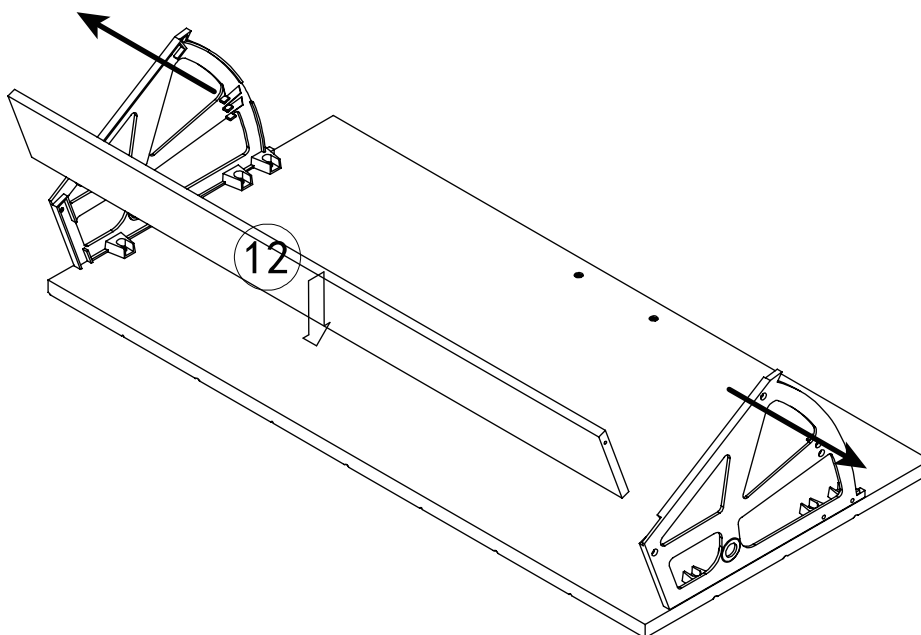

X2

PRODUCT ASSEMBLY

Step 15

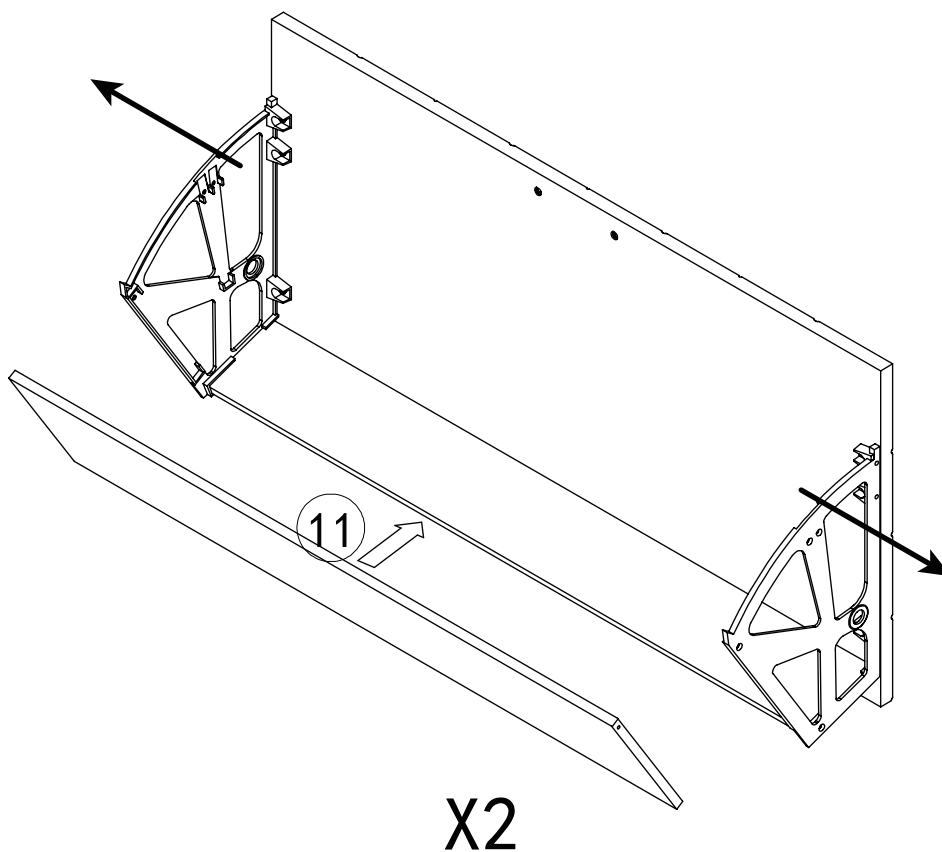

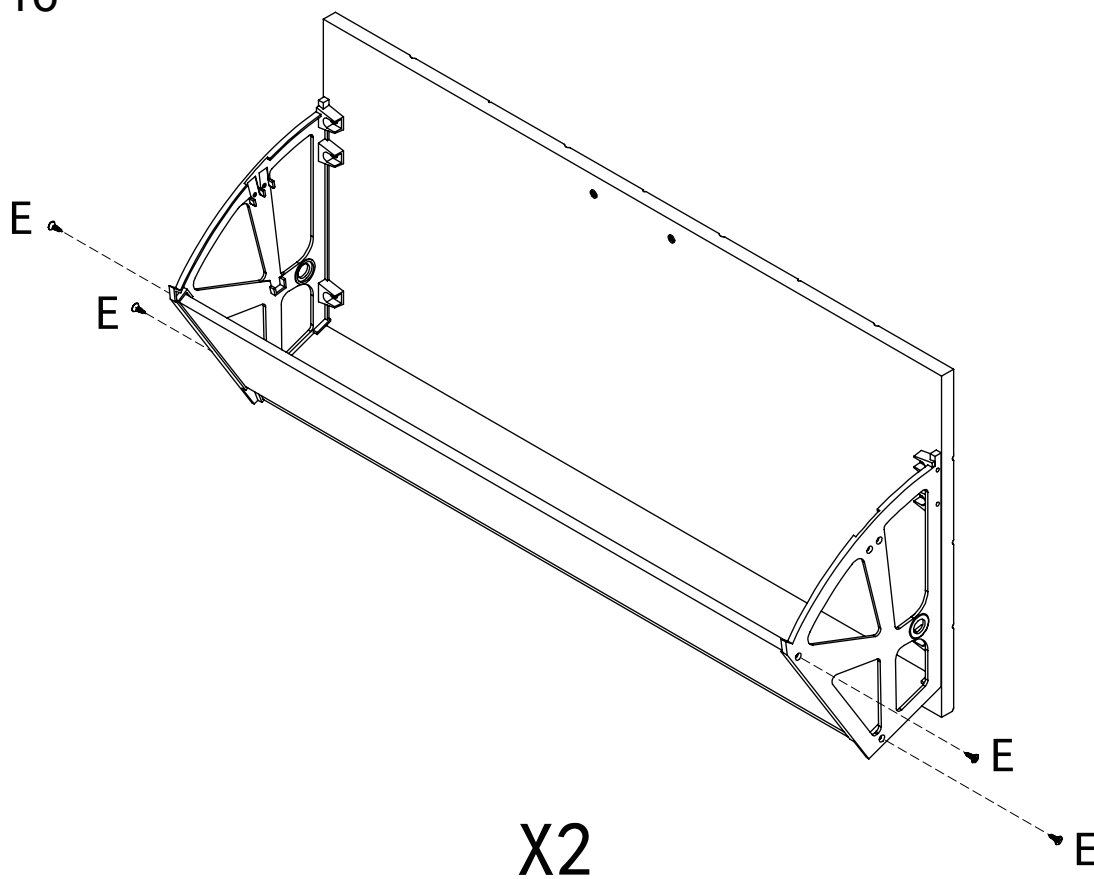

Step 16



E		8 pcs
---	---	-------

PRODUCT ASSEMBLY

Step 17

I		2 pcs
L		2 pcs

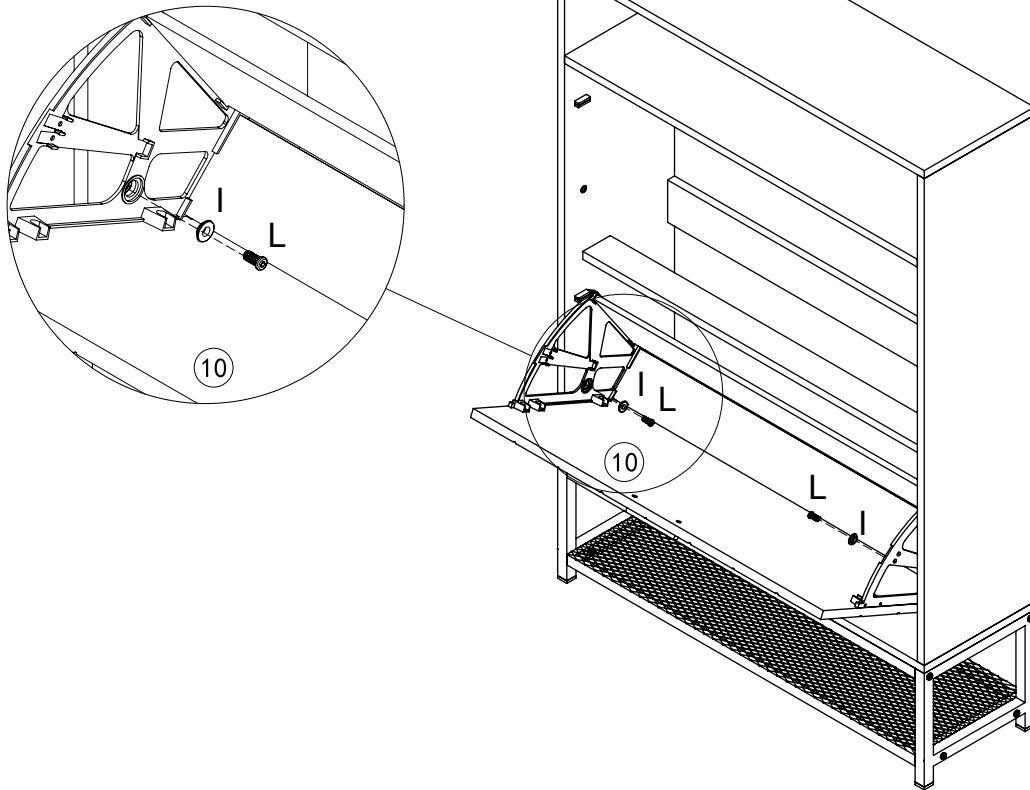

Step 18

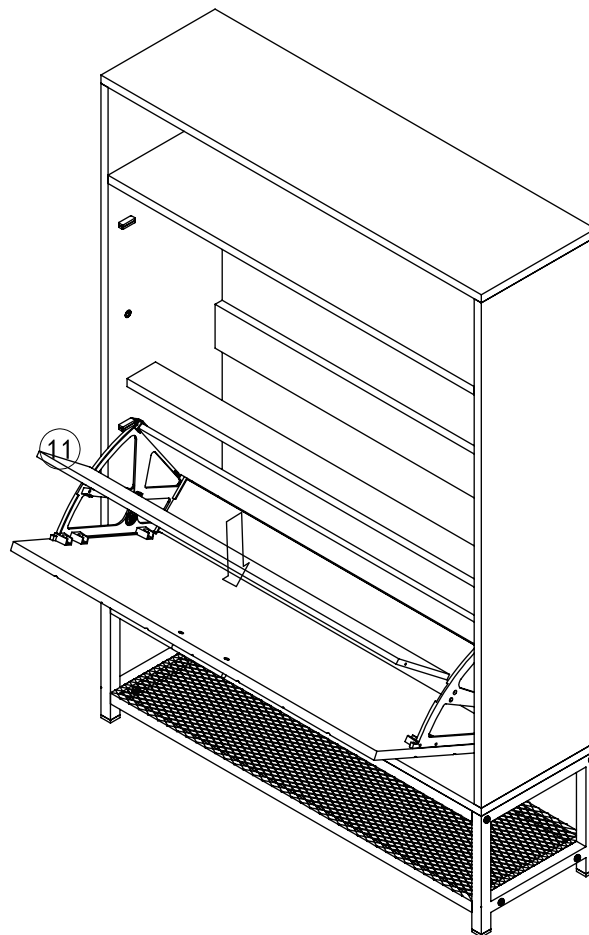



PRODUCT ASSEMBLY

Step 19

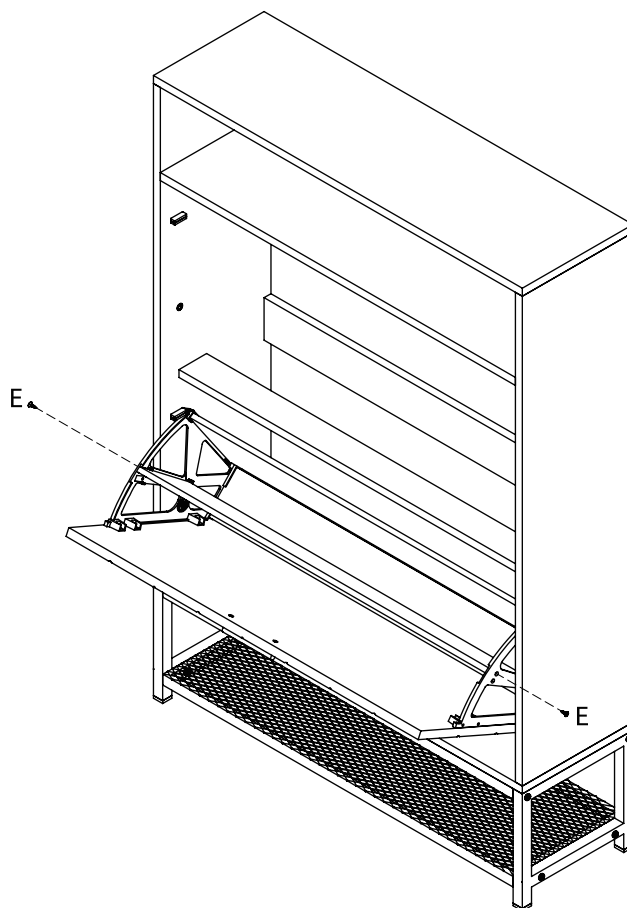
E		2 pcs
---	---	-------



Step 20

I		2 pcs
L		2 pcs

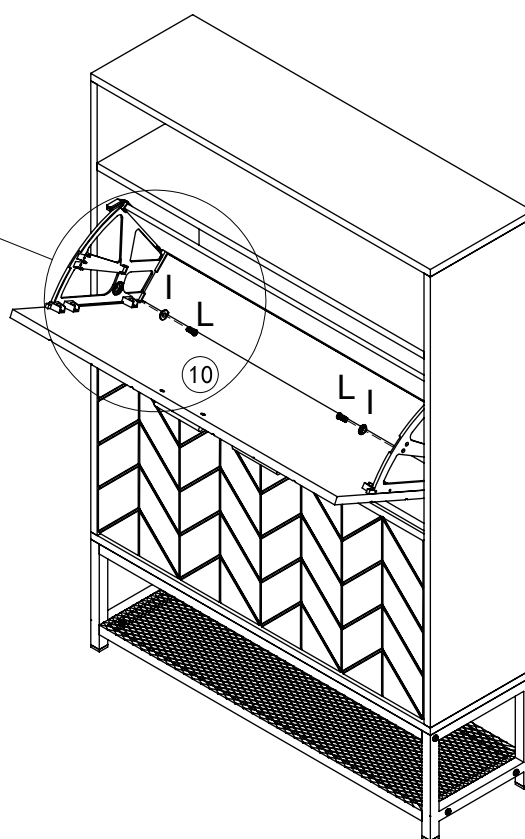
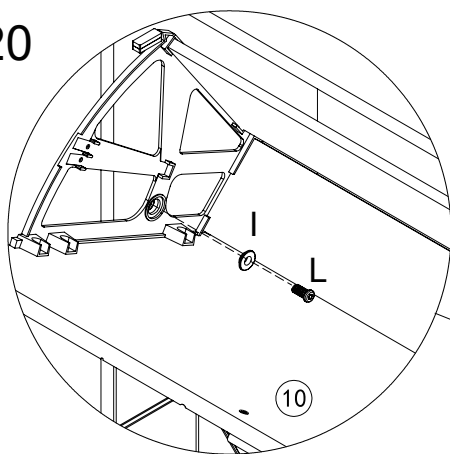

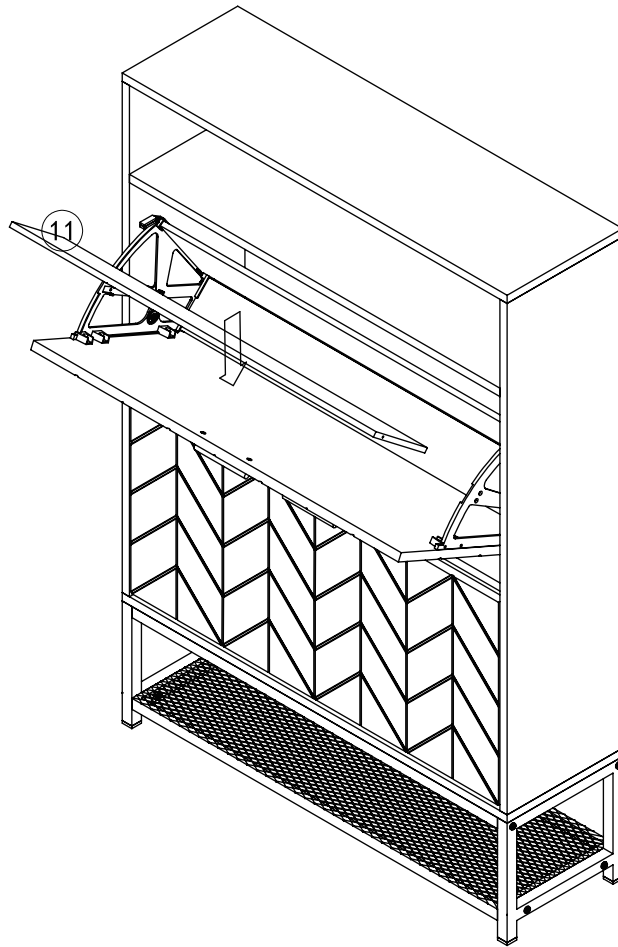

PRODUCT ASSEMBLY

Step 21

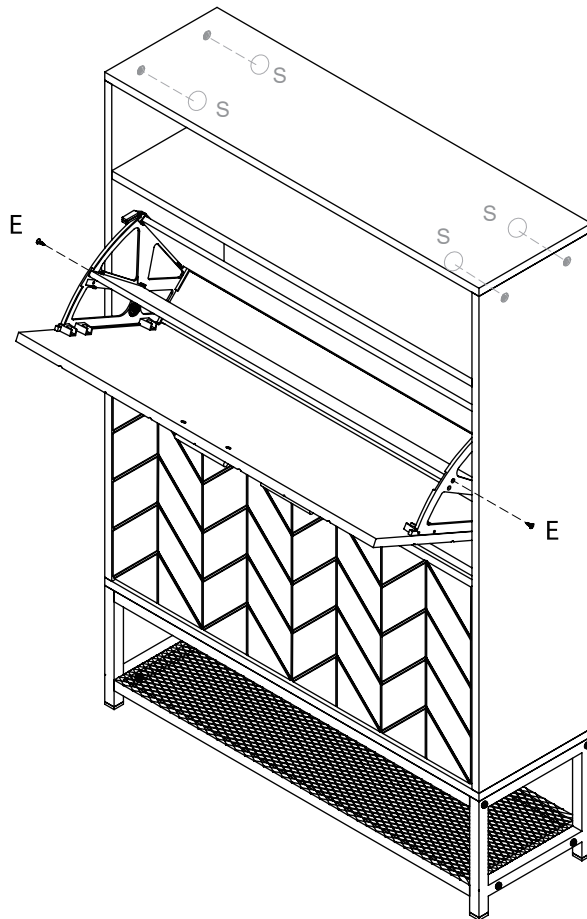

Step 22



E		2 pcs
S		4 pcs

Step 23

Q   2 sets

