

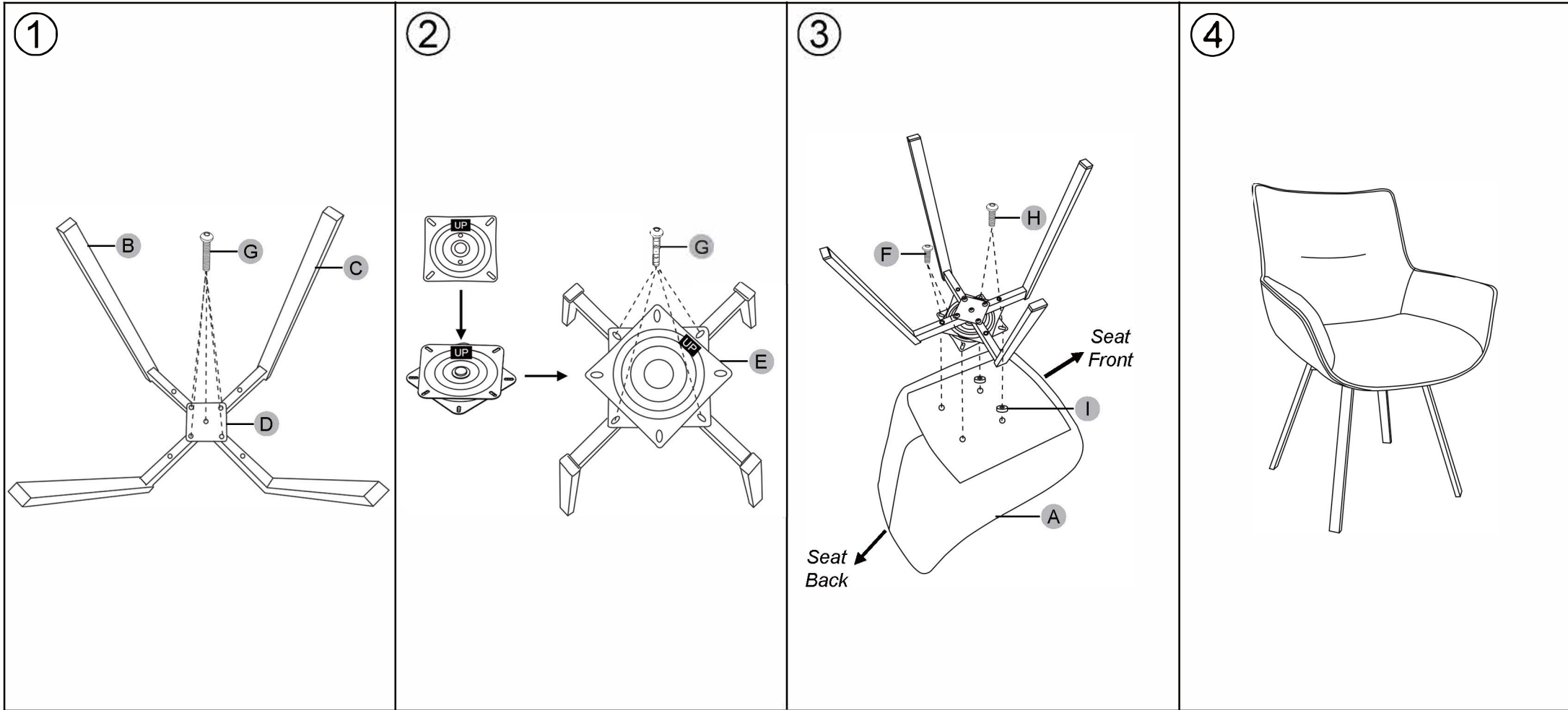





**Assembly Tips:**

- **STEP 2** - Ensure the base plate (#E) is positioned with the "UP" label facing **upward**.
- **STEP 3** - Place the washers (#I) at the **FRONT** of the seat.
- **IMPORTANT** - **DO NOT** fully tighten the screws **until** all screws are properly placed into their holes.

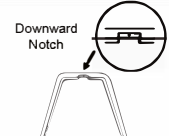
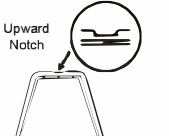
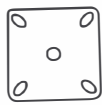
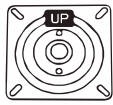
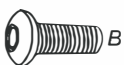

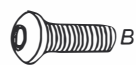
<p><b>A</b></p>  <p>x1</p>	<p><b>B</b></p>  <p>x1</p>	<p><b>C</b></p>  <p>x1</p>	<p><b>D</b></p>  <p>80*80*2.1 mm</p> <p>x1</p>	<p><b>E</b></p>  <p>#154</p> <p>x1</p>
<p><b>F</b></p>  <p>M6*16 mm</p> <p>x2</p>	<p><b>G</b></p>  <p>M6*30 mm</p> <p>x9</p>	<p><b>H</b></p>  <p>M6*25 mm</p> <p>x2</p>	<p><b>I</b></p>  <p>25*10*5 mm</p> <p>x2</p>	<p><b>J</b></p>  <p>M6</p> <p>x1</p>