

ASSEMBLY INSTRUCTION

BS27

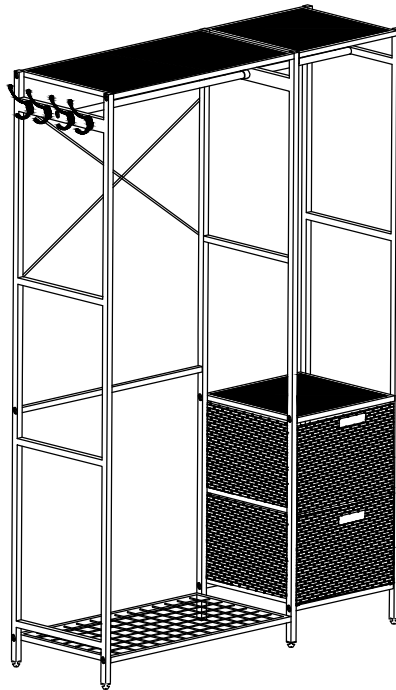

Notice:

1. 50% Tighten before fixings all screws, Allen wrench is recommended instead of an electric drill.
2. Place the item on a flat ground to adjust and make sure it remains stable.
3. Tighten up all screws with tools gradually.
4. If the screws are not aligned with holes during assembly, please loosen all the other screws to 50% and continue the assembly process.
5. If the item is not stable, please loosen all the screws, adjust it on a flat ground and tighten up all screws again.
6. Note: If one or more screws are fully tightened during assembly, chances are the others will not be aligned with holes. In addition, all the holes are designed to be relatively larger to provide more space for the adjustment of the screws.

I - PARTS AND HARDWARE

A x 1

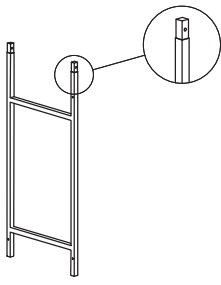

Frame 01

B x 1

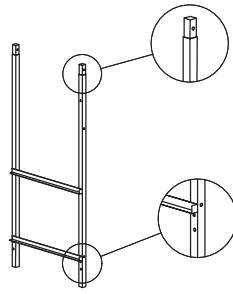

Frame 02

C x 1

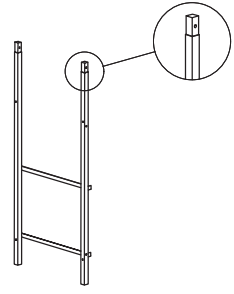

Frame 03

D x 1

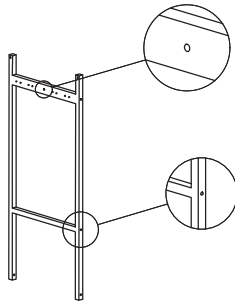

Frame 04

E x 1

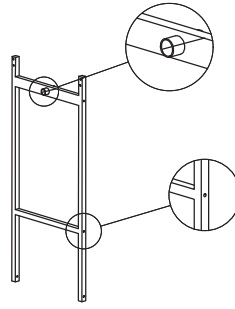

Frame 05

F x 1

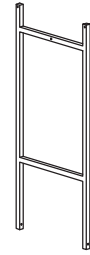

Frame 06

G x 1

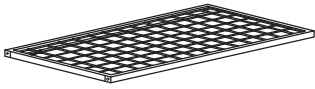

Bottom Grid

H x 1



Large Wooden Top

I x 1

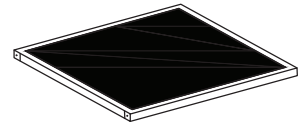

Small Wooden Top 1

K x 1

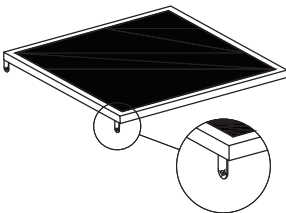

Small Wooden Top 2

L x 1

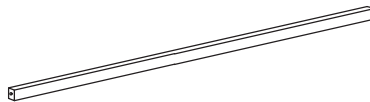

Long square bar

M x 2



Short square bar

N x 1

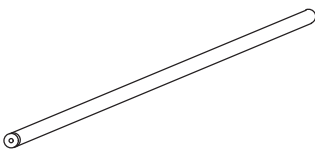

Long round bar

O x 1

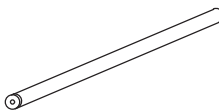

Short round bar

P x 2

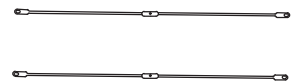

Long X brace

I - PARTS AND HARDWARE

Q x 2

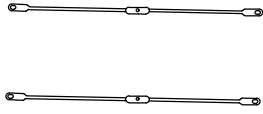

Short X brace

R x 2

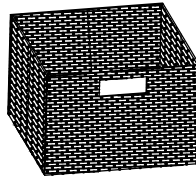

Poly rattan box

①x22

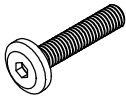

Bolt M6x30

②x12



Bolt M6x10

③x2

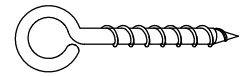

CABLE

④x2

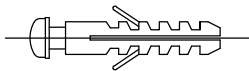

4F

⑤x4



Hanger

⑥x2



Nut

⑦x14



M4x15

⑧x2

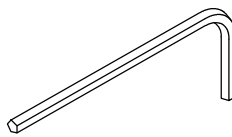

K4

⑨x8



Plastic Strap:
3x100mm

⑩x2



Plastic Strap:
3x200mm

⑪x6



Plastic feet
D20/7- M6

⑫x1

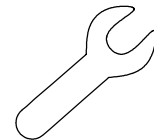

Wrench 10

II - PRODUCT ASSEMBLY: Shelves

"DO NOT tighten the screws until all of parts set into correct position"

STEP 1:

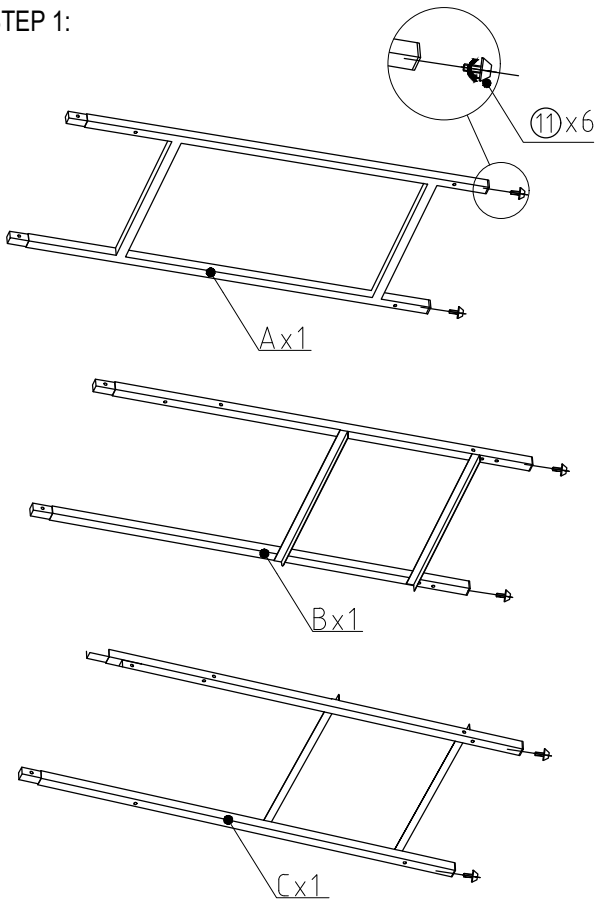

STEP 2:

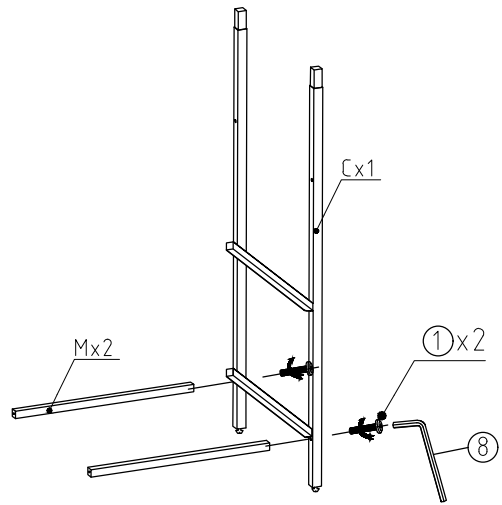

STEP 3:

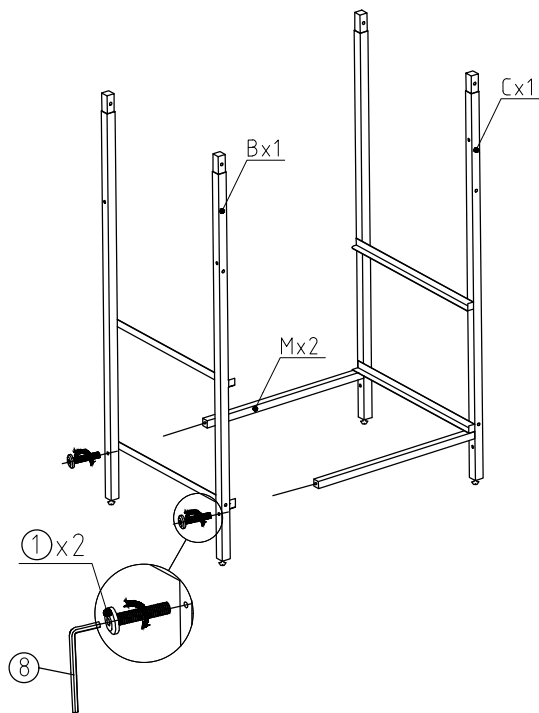

STEP 4:

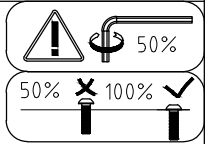
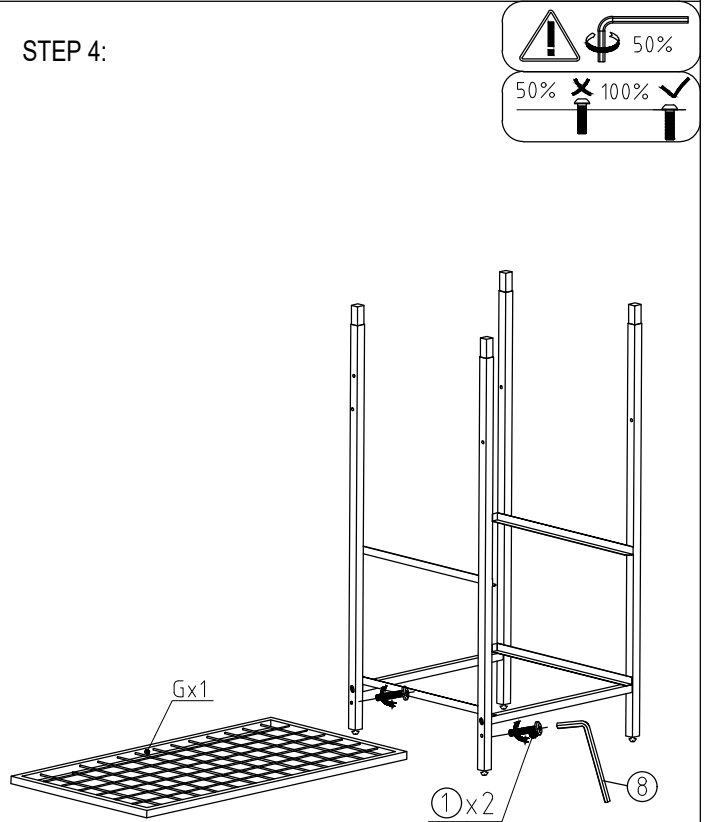

II - PRODUCT ASSEMBLY: Shelves

"DO NOT tighten the screws until all of parts set into correct position"

STEP 5:

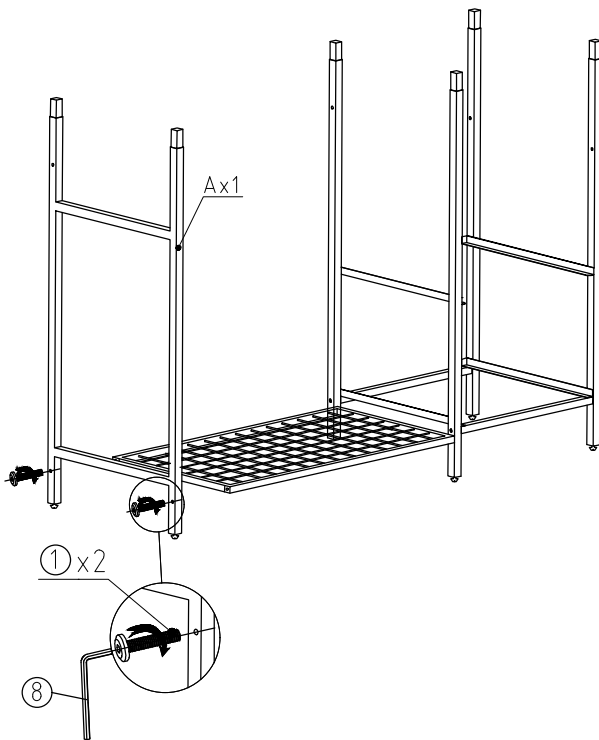
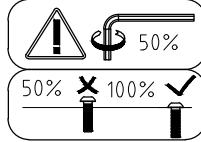

STEP 6:

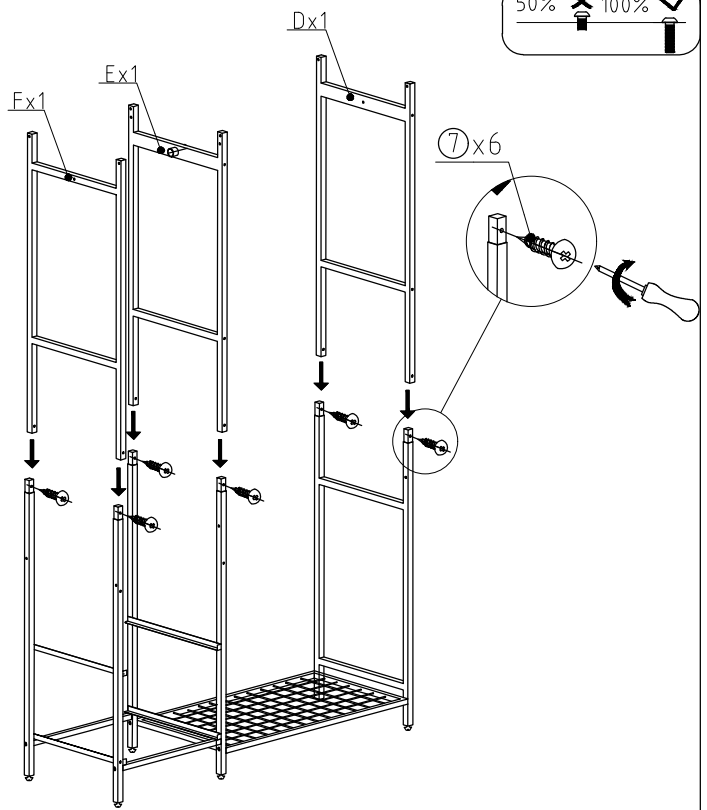
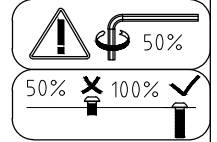

STEP 7:

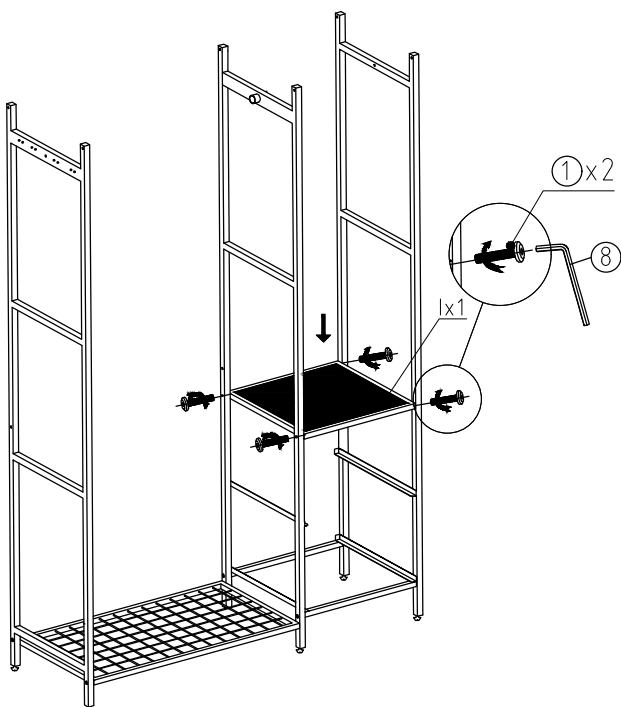
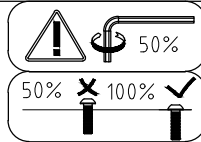

STEP 8:

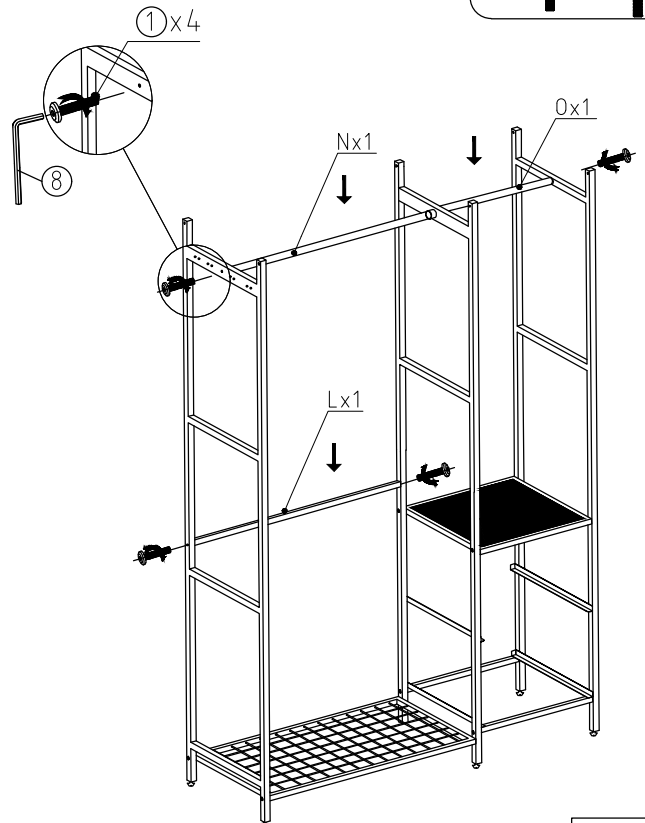
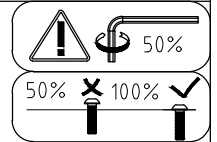

II - PRODUCT ASSEMBLY: Shelves

"DO NOT tighten the screws until all of parts set into correct position"

STEP 9:

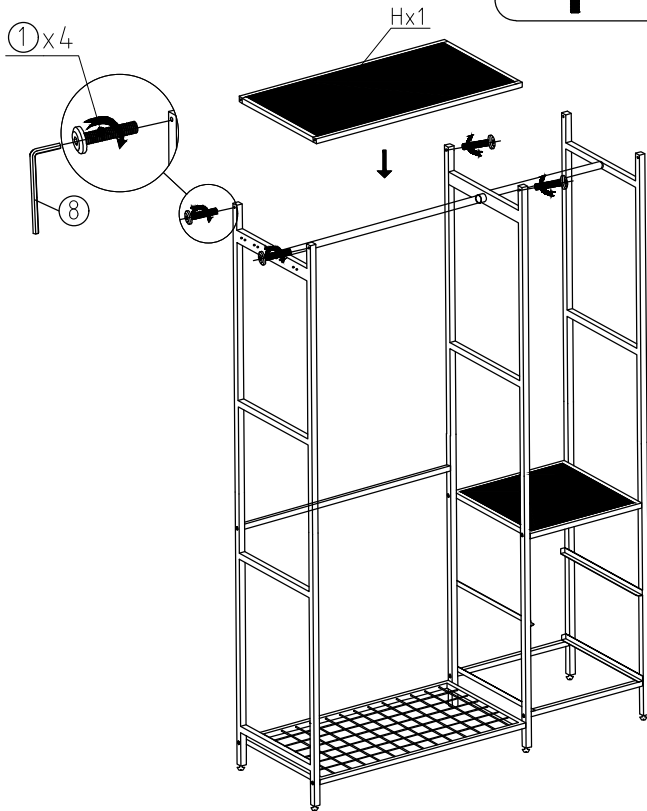
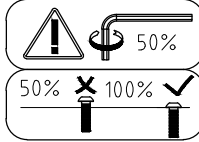

STEP 10:

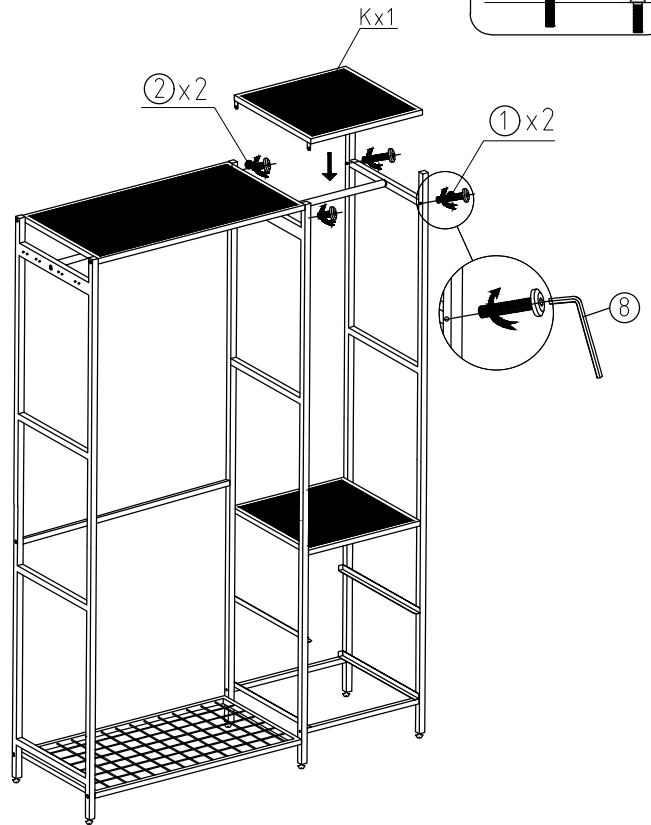
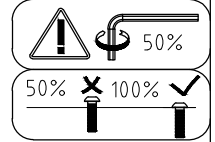

STEP 11:

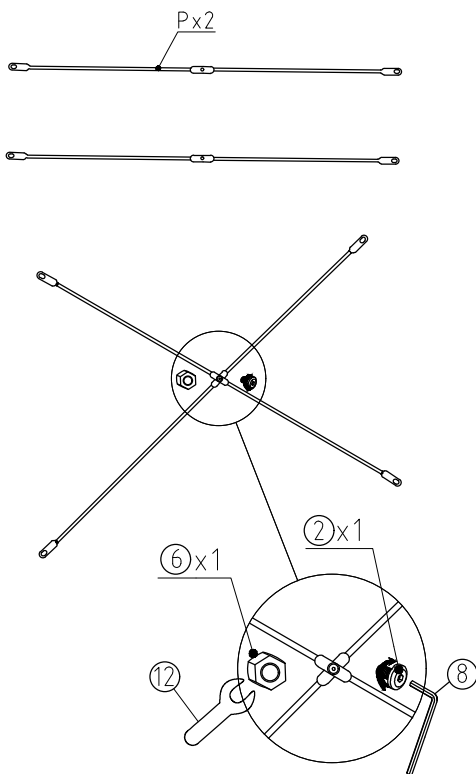
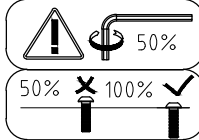

STEP 12:

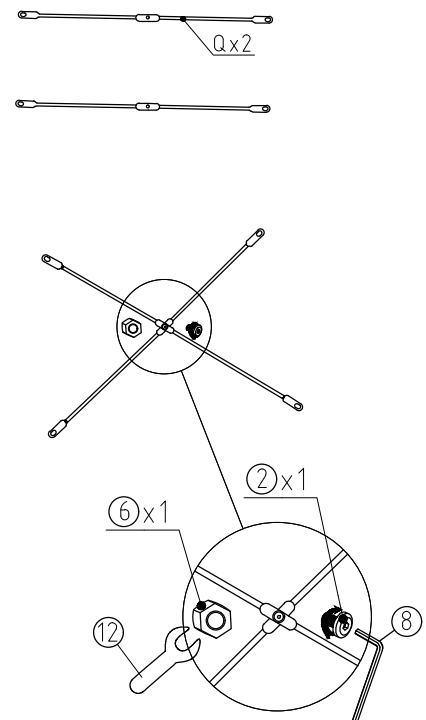
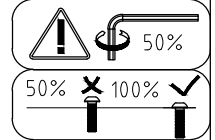

II - PRODUCT ASSEMBLY: Shelves

"DO NOT tighten the screws until all of parts set into correct position"

STEP 13:

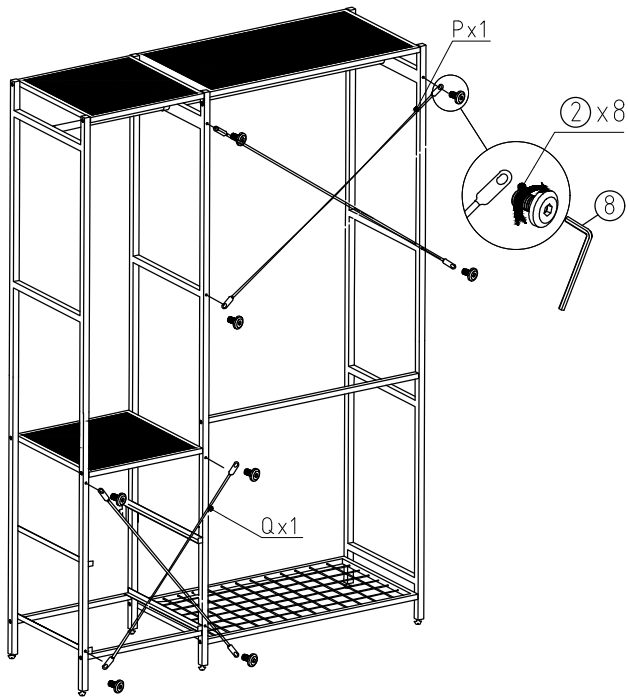
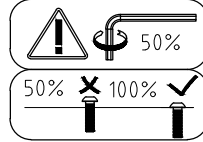

STEP 14:

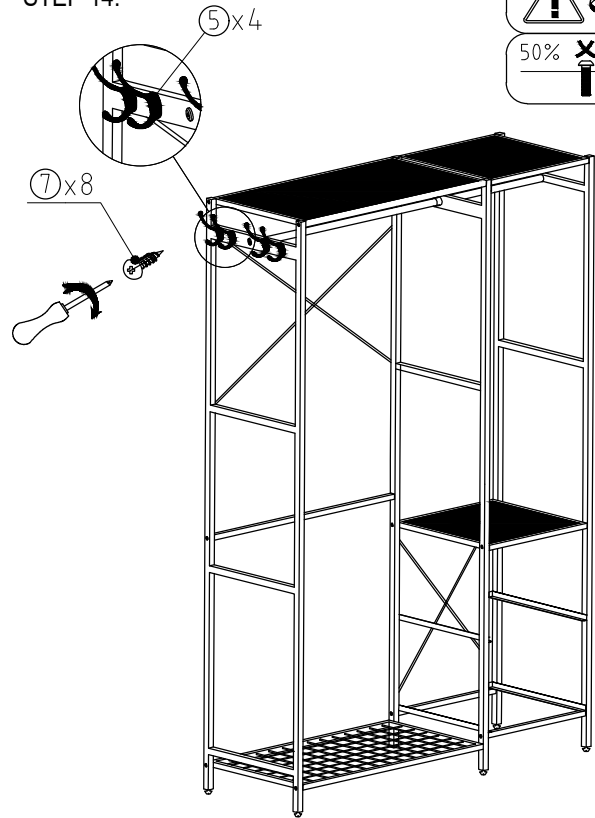
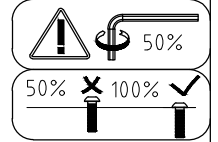

STEP 15:

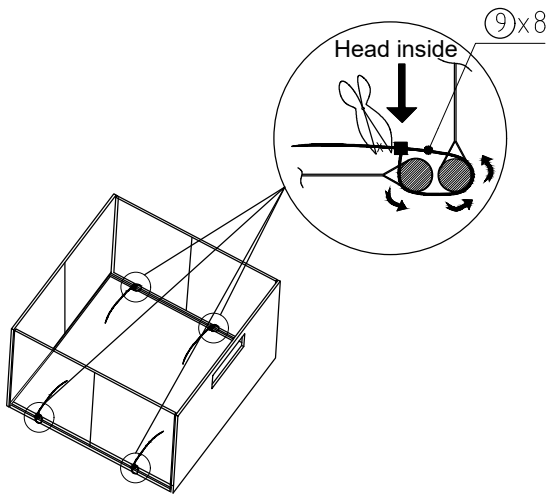
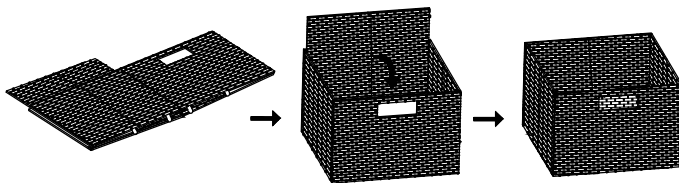

1. Point the head of the cable tie towards the inside of the box.
2. Tighten and cut off the excess length of the cable tie.

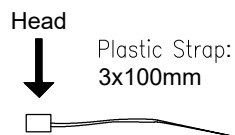

STEP 16:

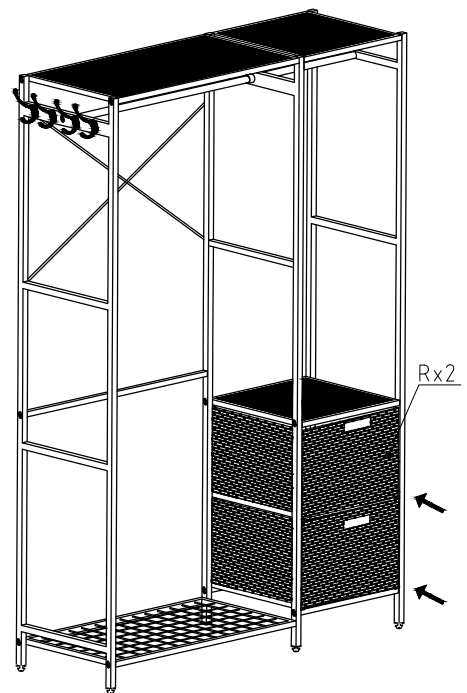

STEP 17:

FINISH/COMPLETE

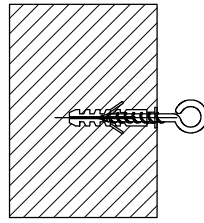
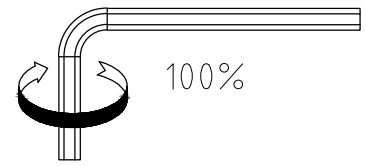

A-A

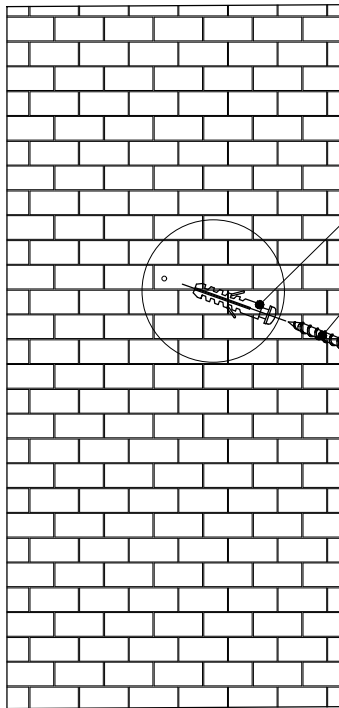

④x2

③x2

⑩x2

Plastic Strap:
3x200mm

