

Assembly Instruction

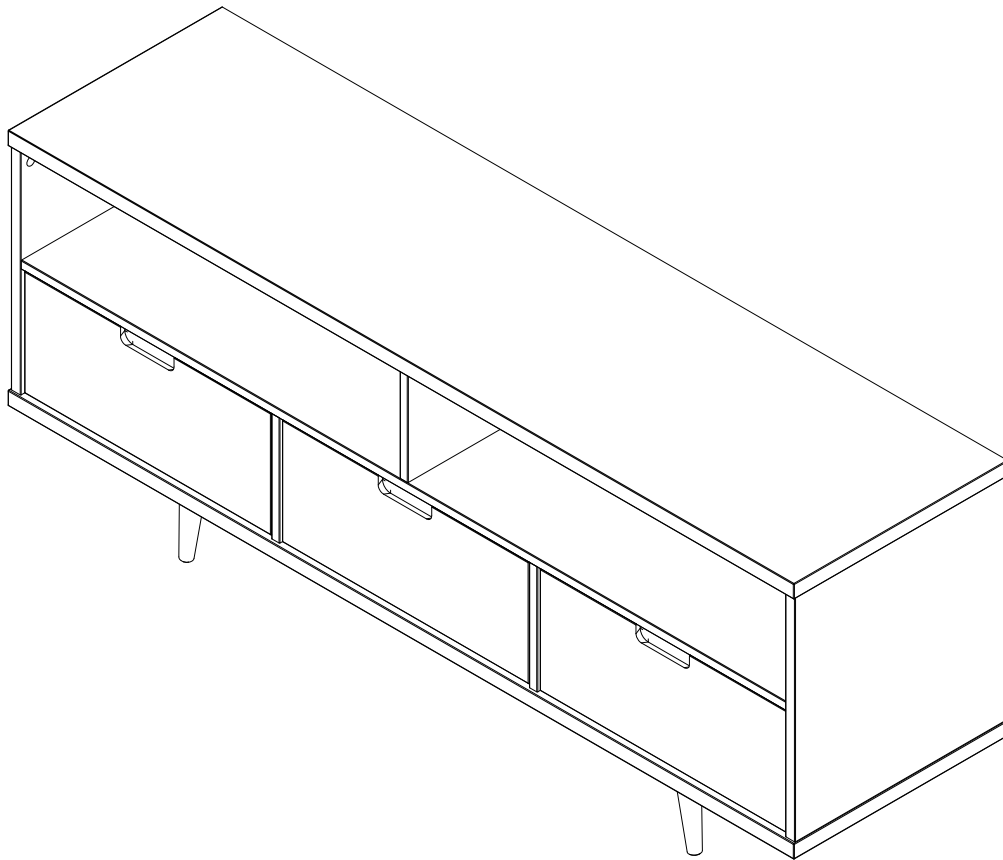

General Assembly Guidelines

- I. Ensure that all parts and hardware are available before beginning assembly.
- II. Follow each step carefully to ensure the proper assembly of this product.
- III. Two people are recommended for ease in the assembly of this product.
- IV. The three main types of hardware used to assemble this product are : wood dowels , screws and bolts.
- V. A Phillips head screwdriver is required for the assembly of this product .

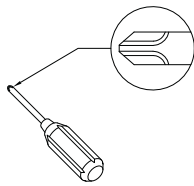



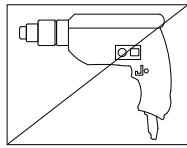

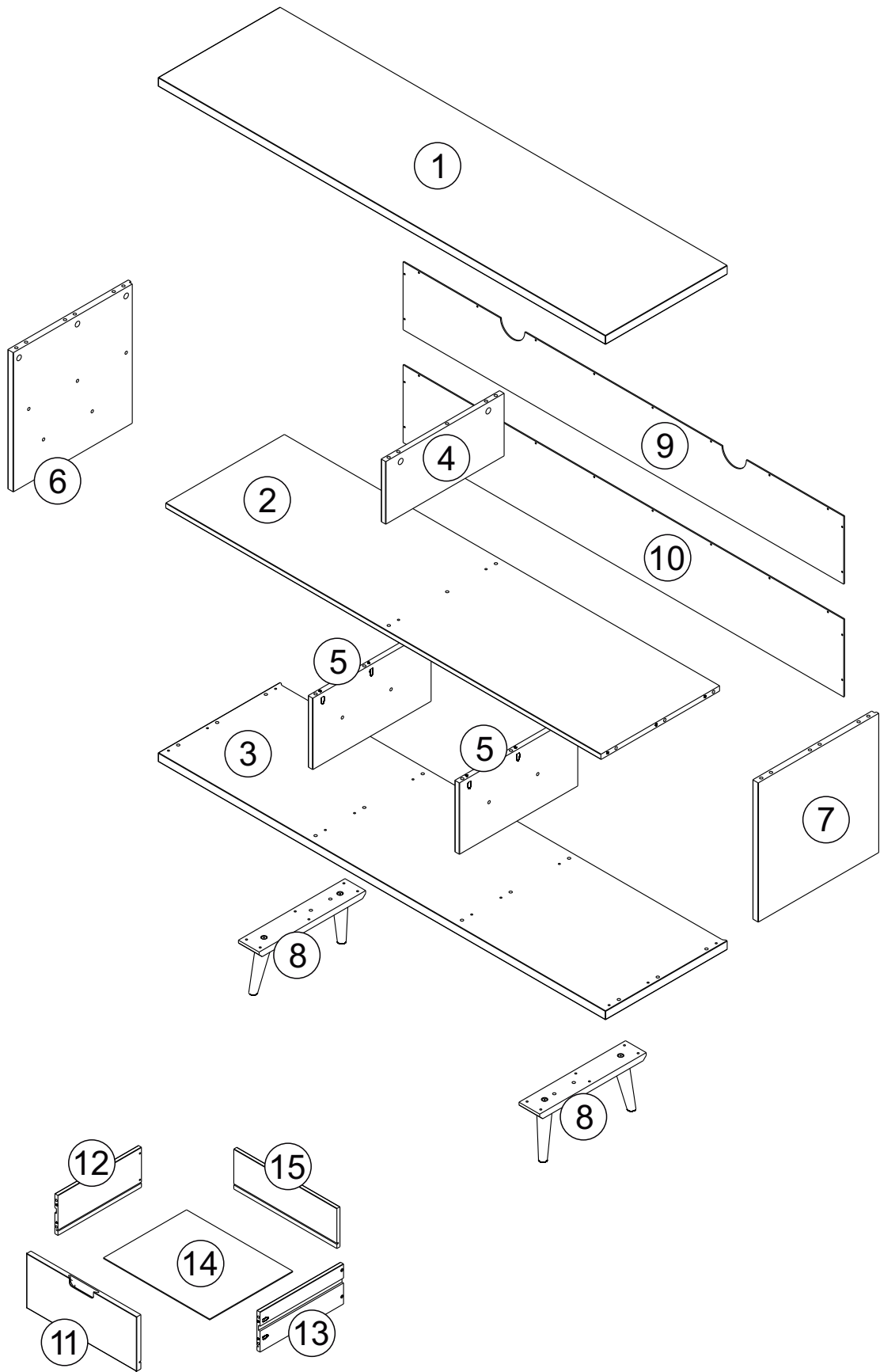

- VI. Power tools should not be used to assemble this product .

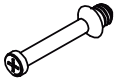

Parts List

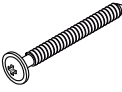
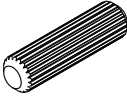

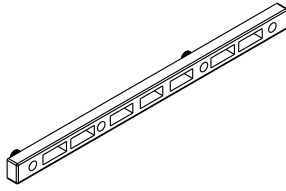
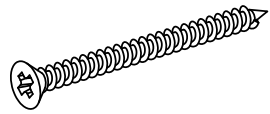
Hardware List

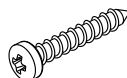
A		Ø 5,5x28mm	Cam Bolt	08 pcs
B		Ø 14x14mm	Cam Lock	08 pcs
C		Ø 3,5x30 mm	Screw	48 pcs
D		Ø8x30 mm	Wood dowel	52 pcs
E		Ø 3,5x16 mm	Screw	36 pcs
F			Plastic Slide	06 pcs
G		Ø 3,5x40mm	Screw	14 pcs
H				08 pcs
I		Ø 3,5x20 mm	Screw	08 pcs

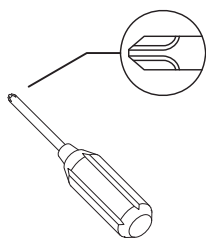

Philips head screwdriver required for assembly
(not included)

*The hardware quantities listed above are required for proper assembly.
Some extra hardware may also have been included.*

Step 1

Insert wood dowel (D) into parts (2),(4),(5),(6), (7),(8),(12) and (13)

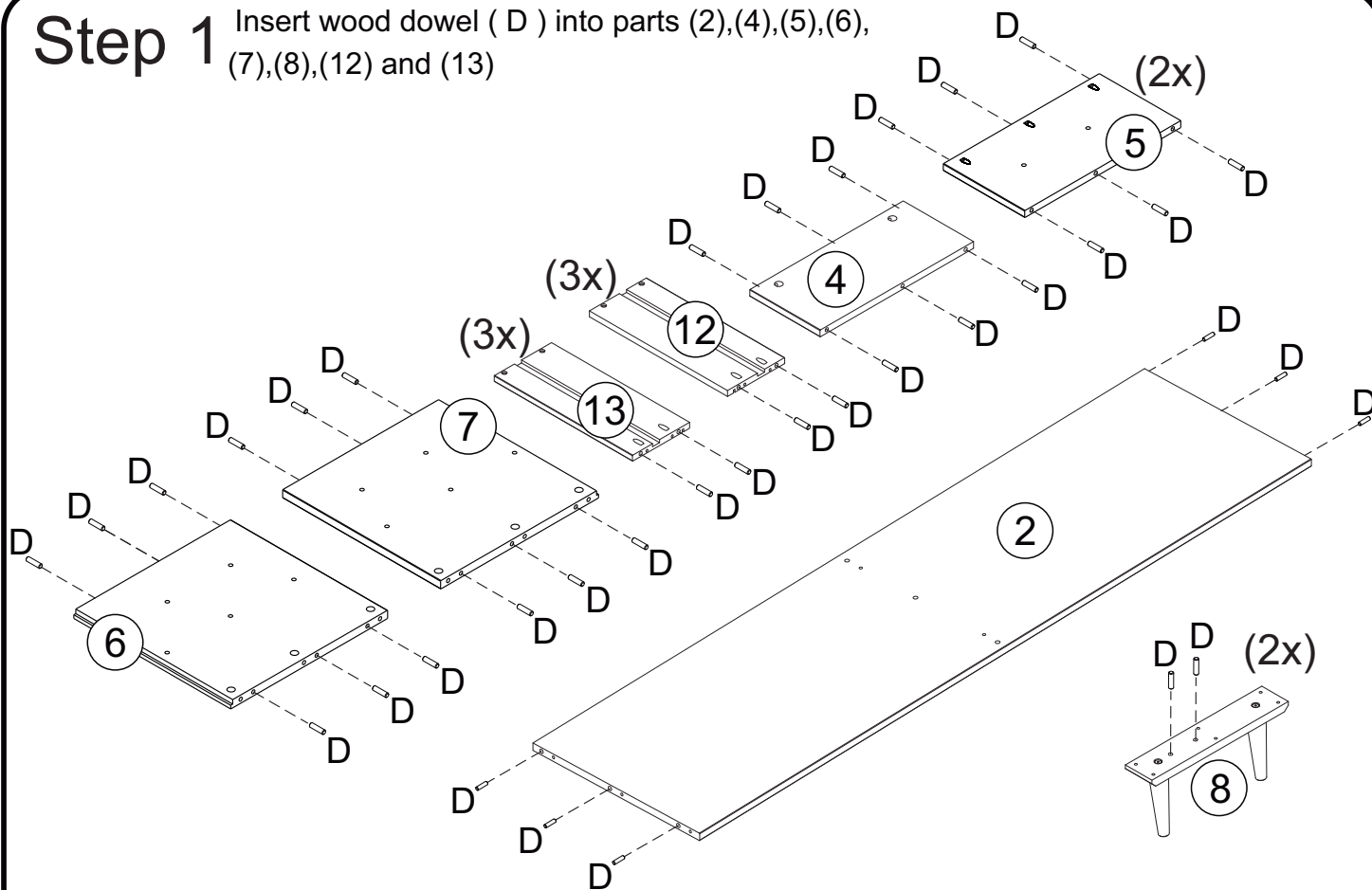

Step 2

Attach the Plastic Slide (F) into part (6) and (7) using Screw (E) and a Phillips head screwdriver. Complete this step twice.

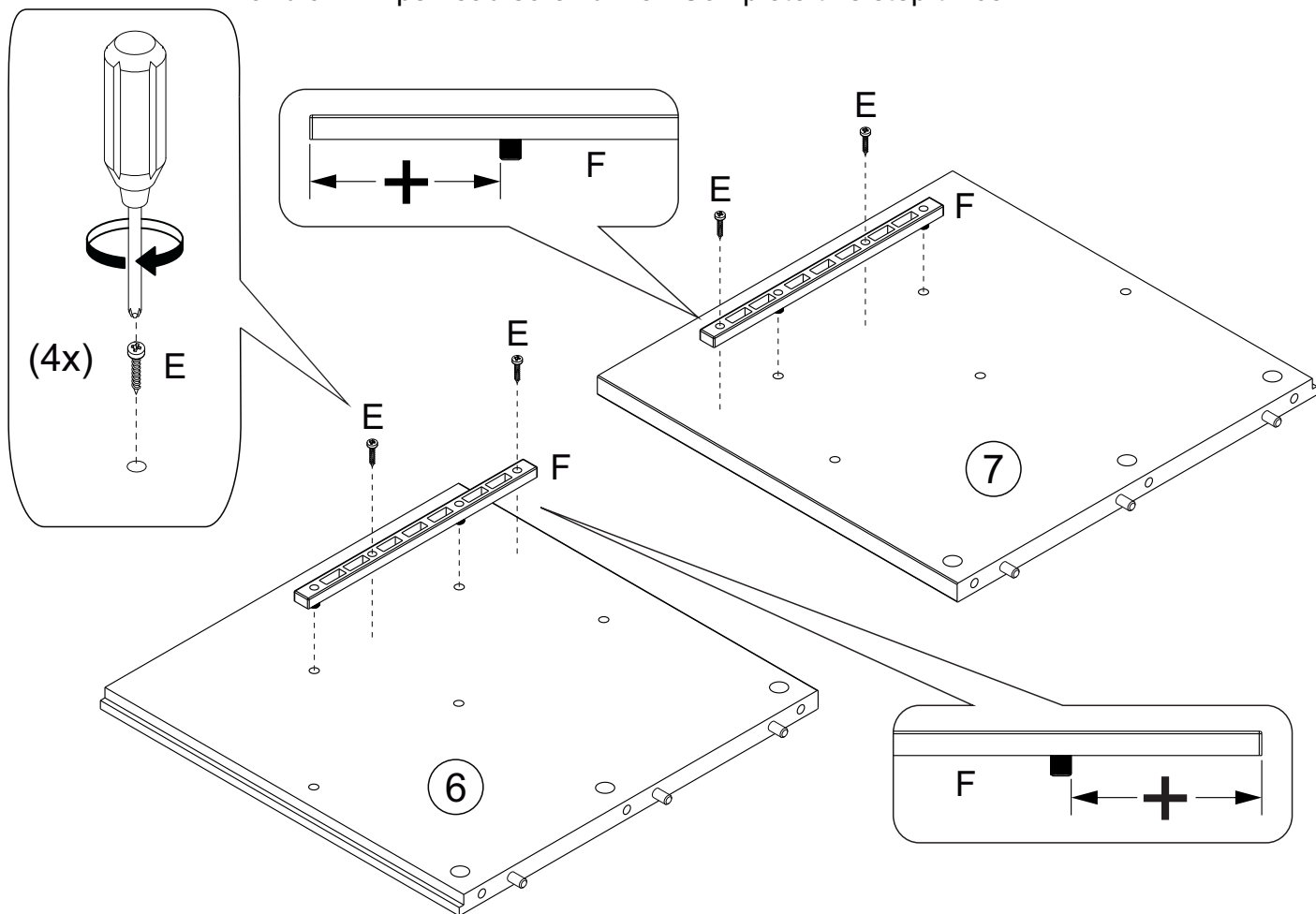

Step 3 Attach the Plastic Slide (F) into part (5) using Screw (I) and a Phillips head screwdriver. Complete this step twice.

2x

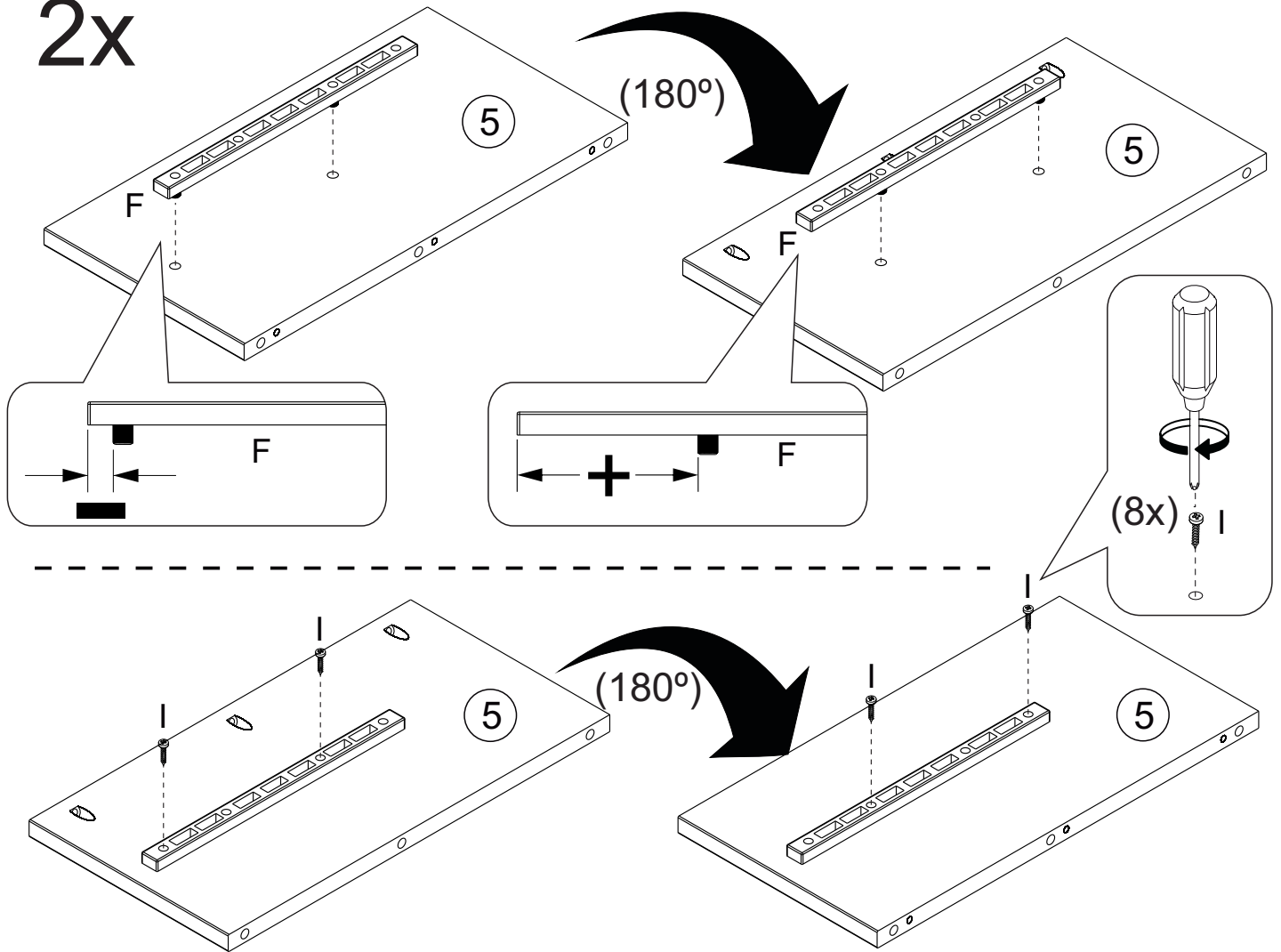

Step 4

Attach Cam Bolt (A) into the holes in the part (1).

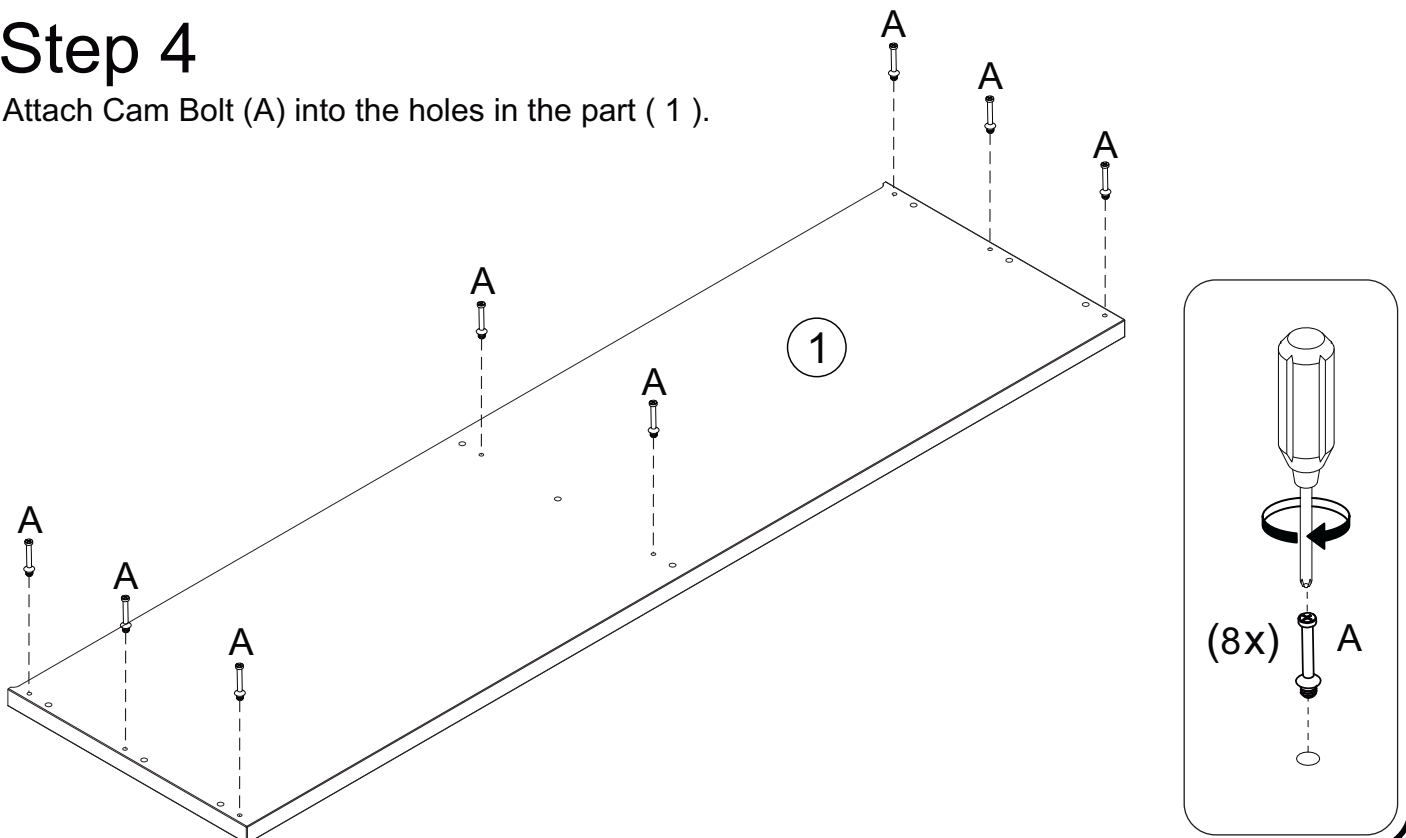

Step 5 Attach part (2) in the holes of part (4) using screw (G) and phillips screw driver.

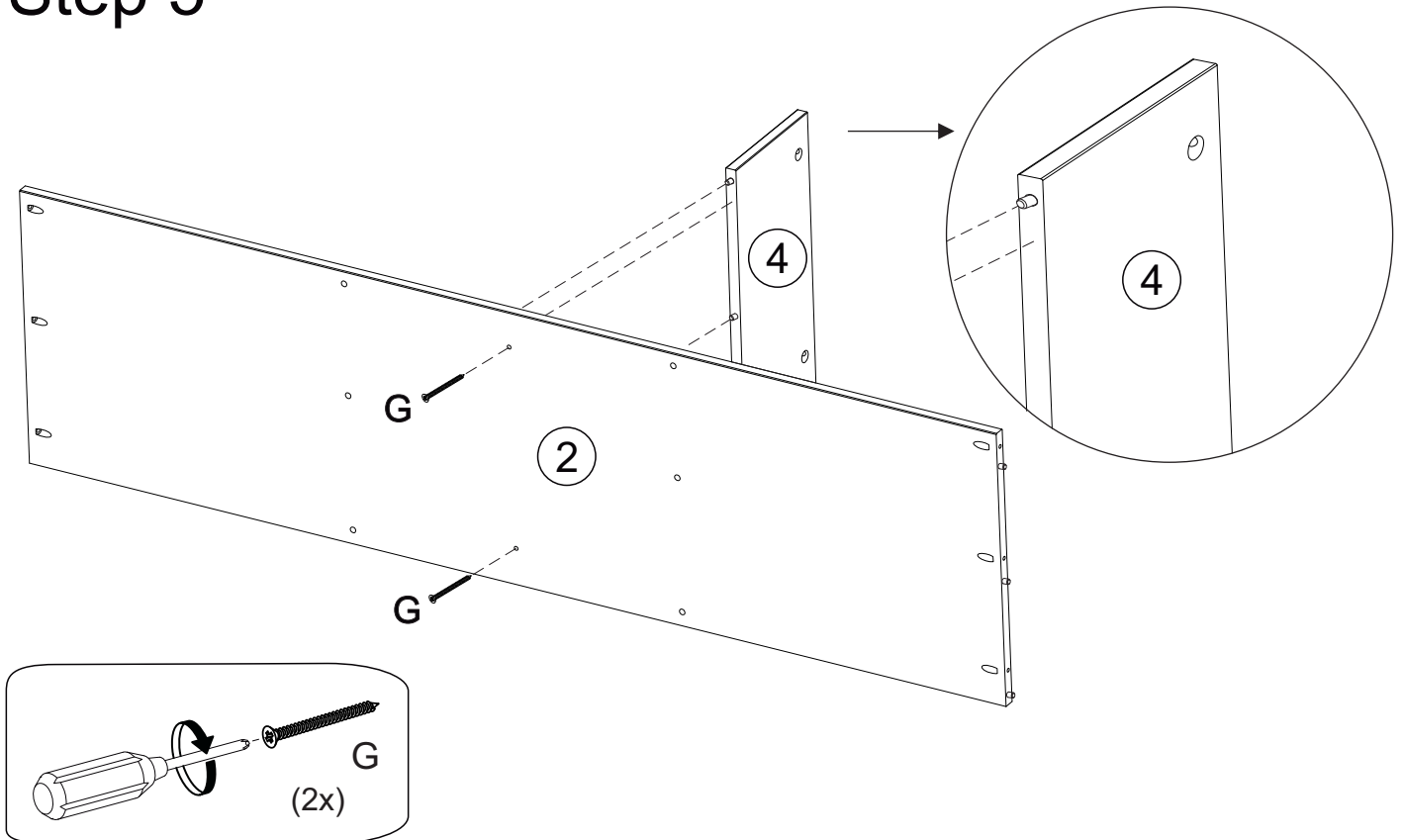

Step 6 Attach part (5) in the holes of part (2) using screw (C) and phillips screw driver.

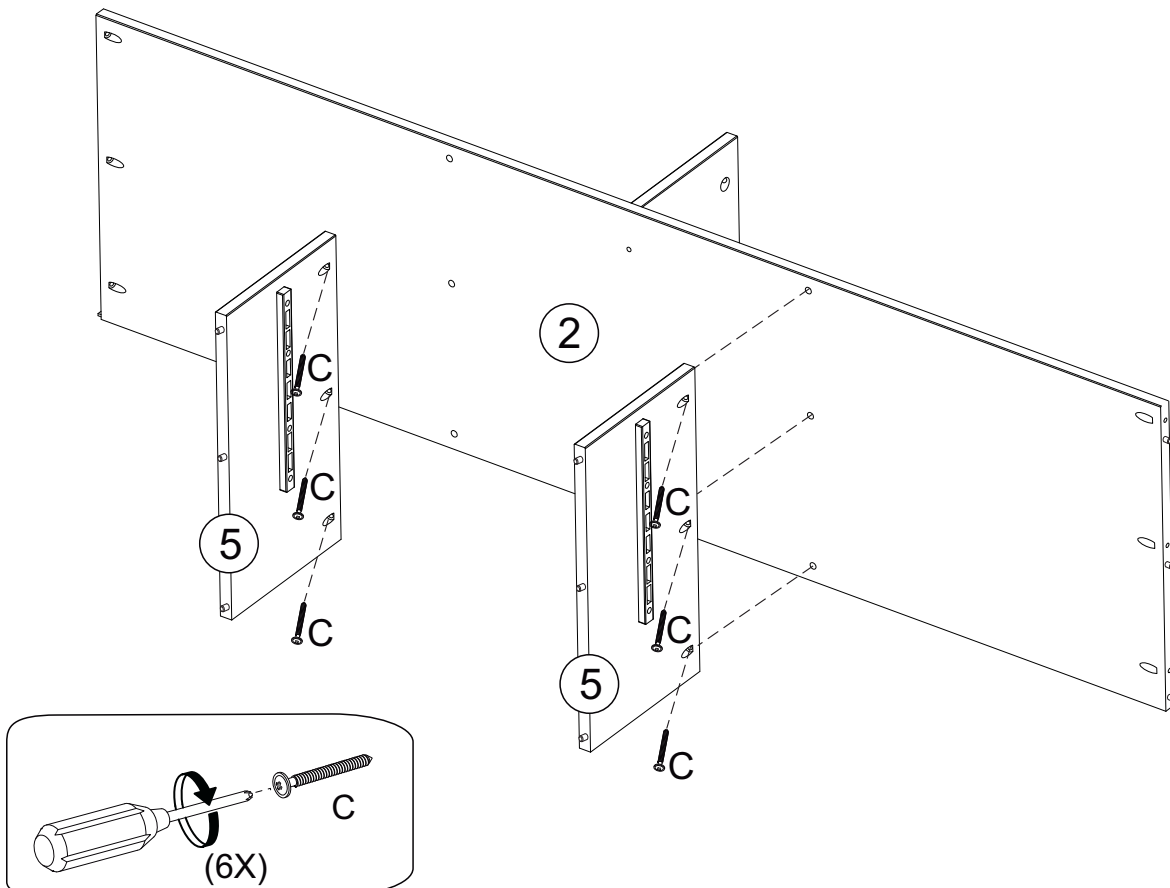

Step 7

Attach holes part (6) and (7) in the wood dowels of part (2) using screw (C) and phillips screw driver.

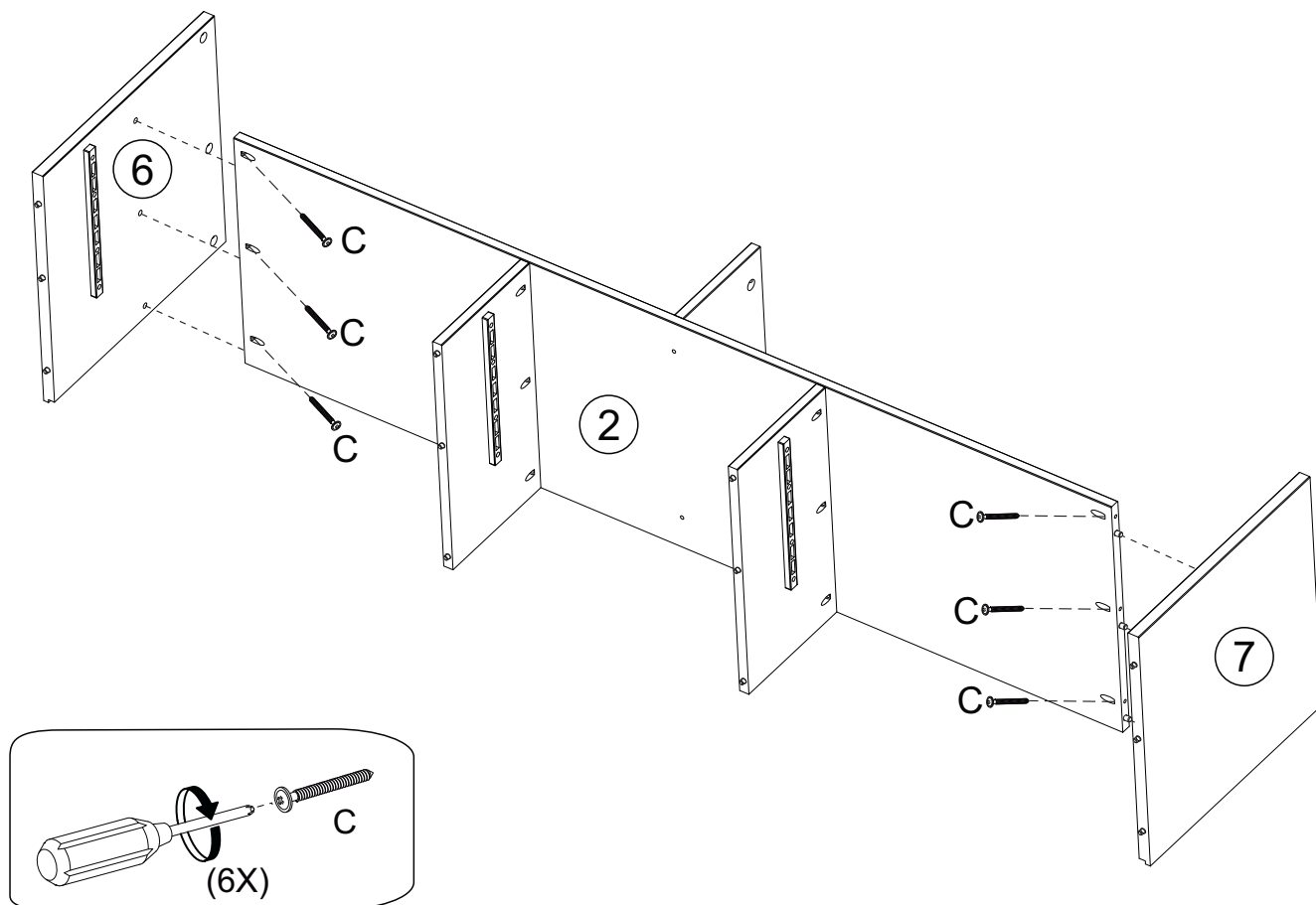

Step 8

Attach part (1) and (3) in the wood dowels of part (6) and (7) using screw (G) and cam bolt (B) and phillips screw driver.

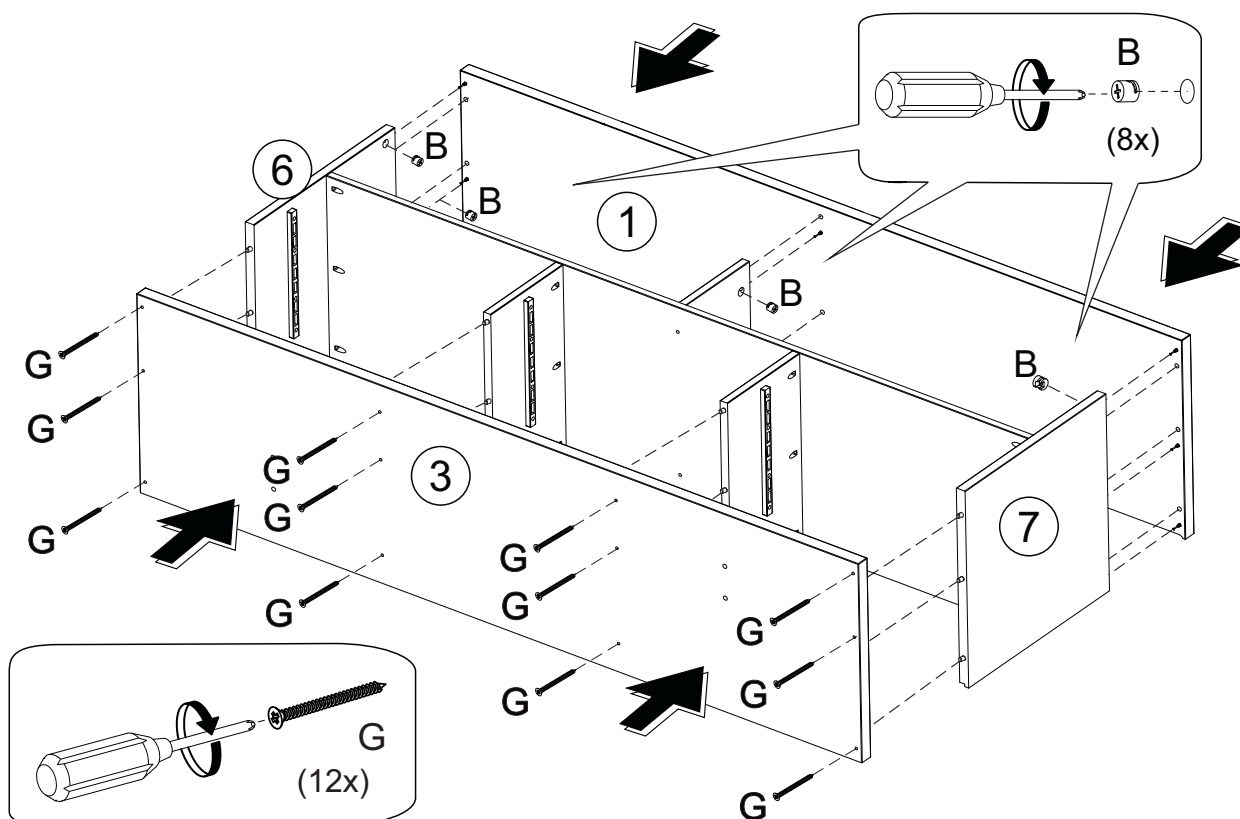

Step 9

Attach part (8) in the part (3) using screw (C) and phillips screw driver.

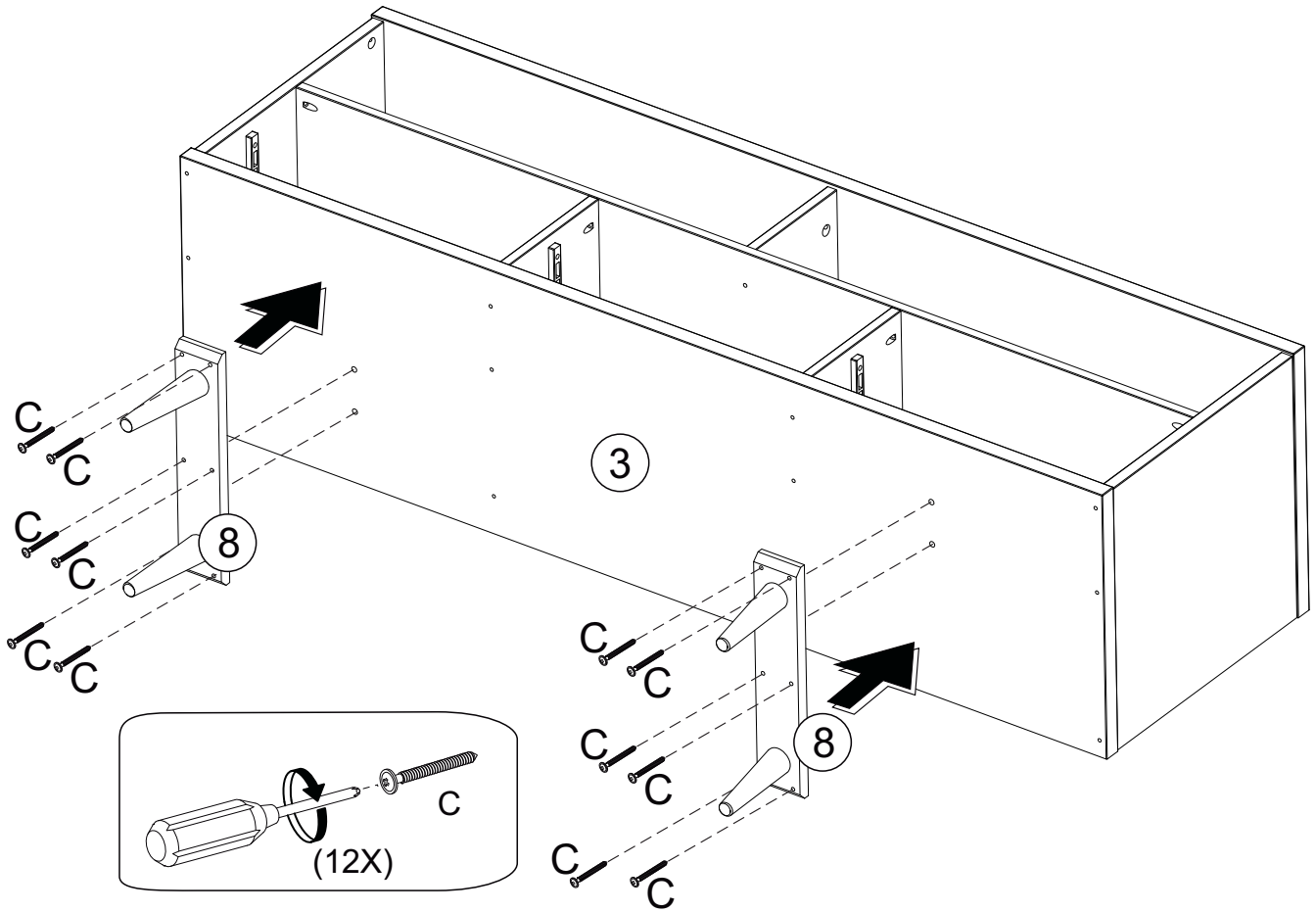

Step 10

Attach part (9) and (10) using screw (E) and hardware (H) and phillips screw driver.

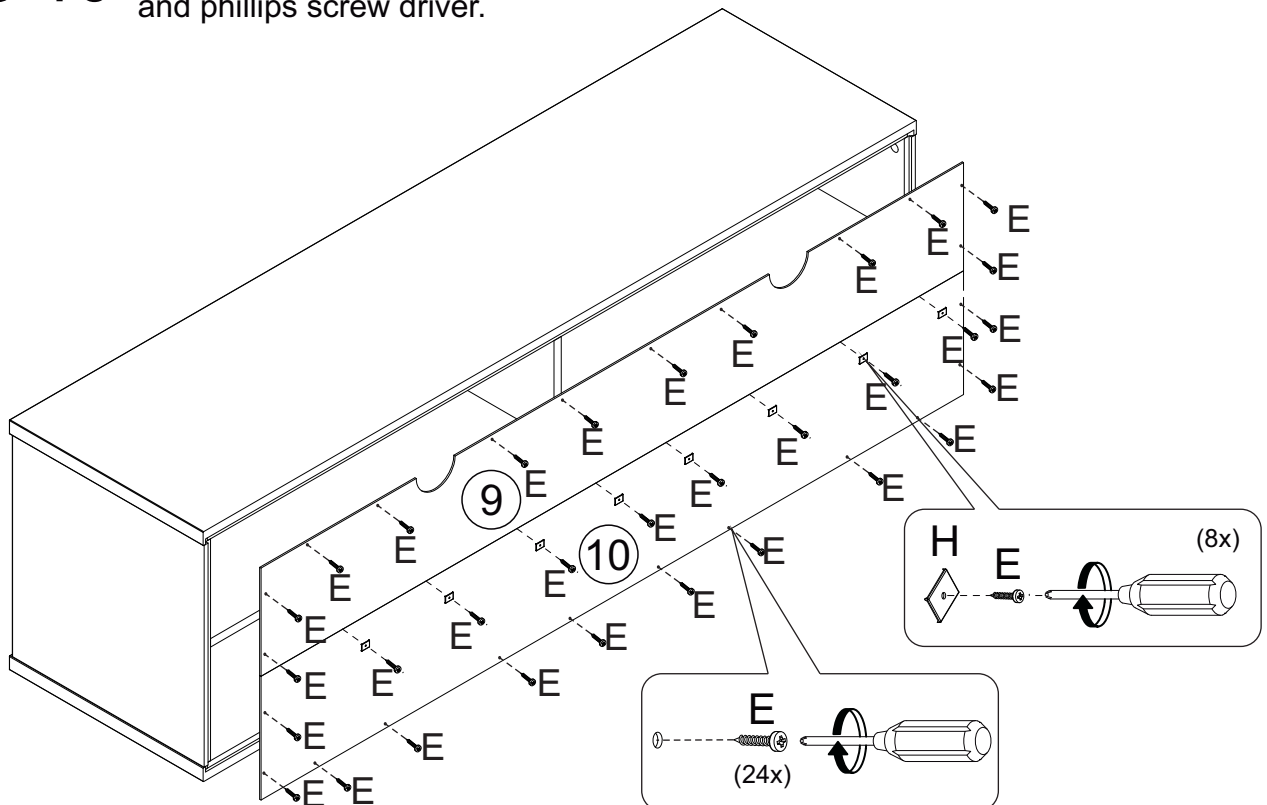

Step 11

Attach part (12) and (13) in the part (11) using screw (C) and phillips screw driver.

3x

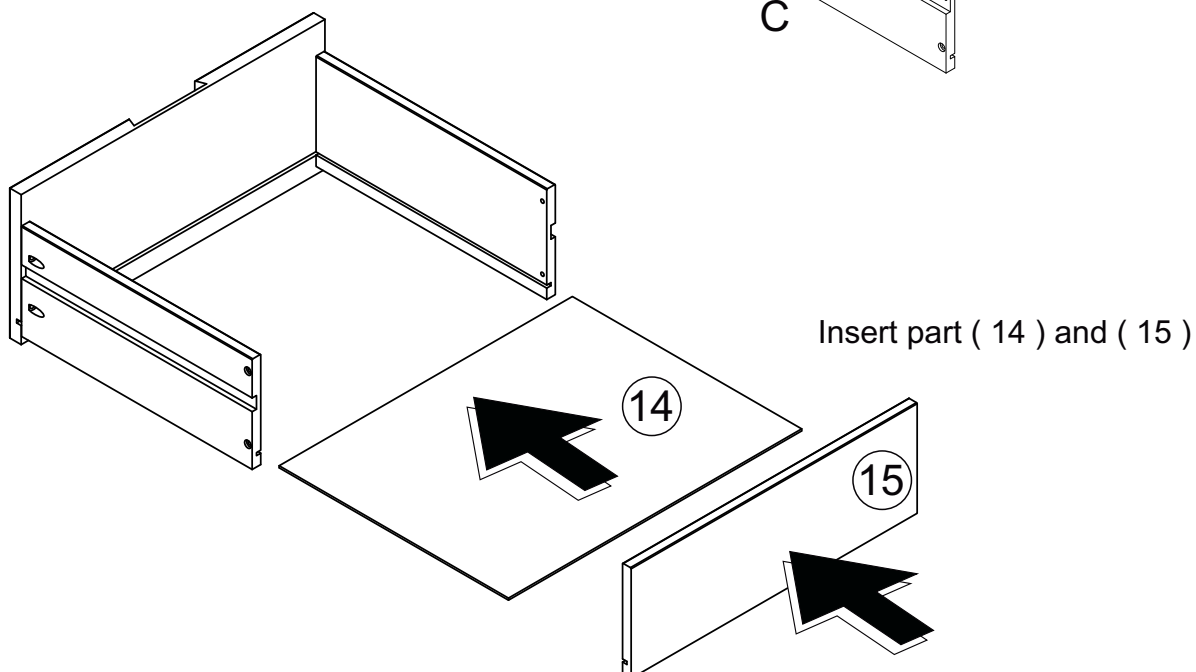
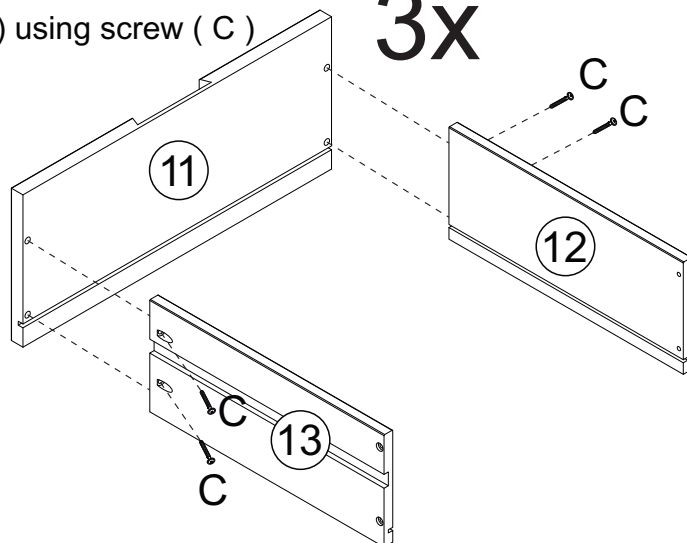

Attach part (12) and (13) in the part (15) using screw (C) and phillips screw driver.

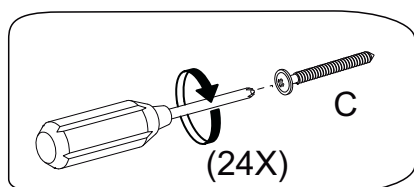
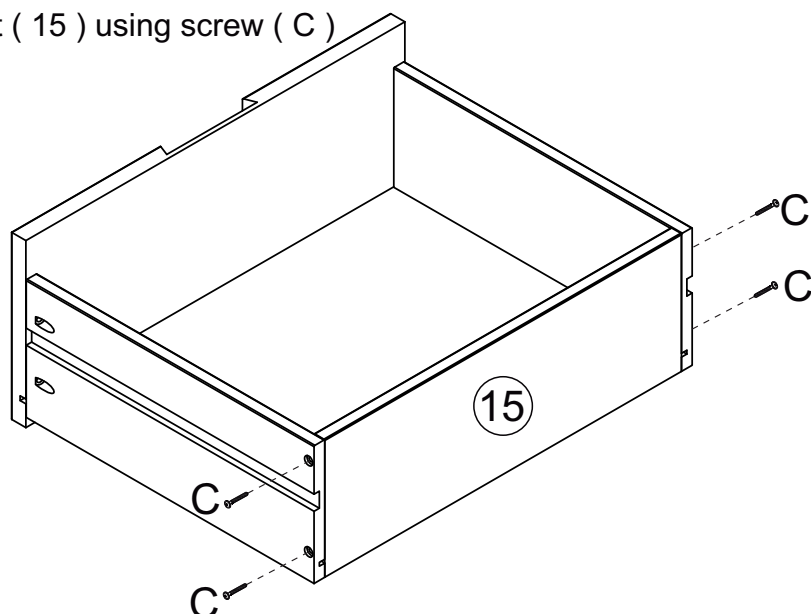

Step 12

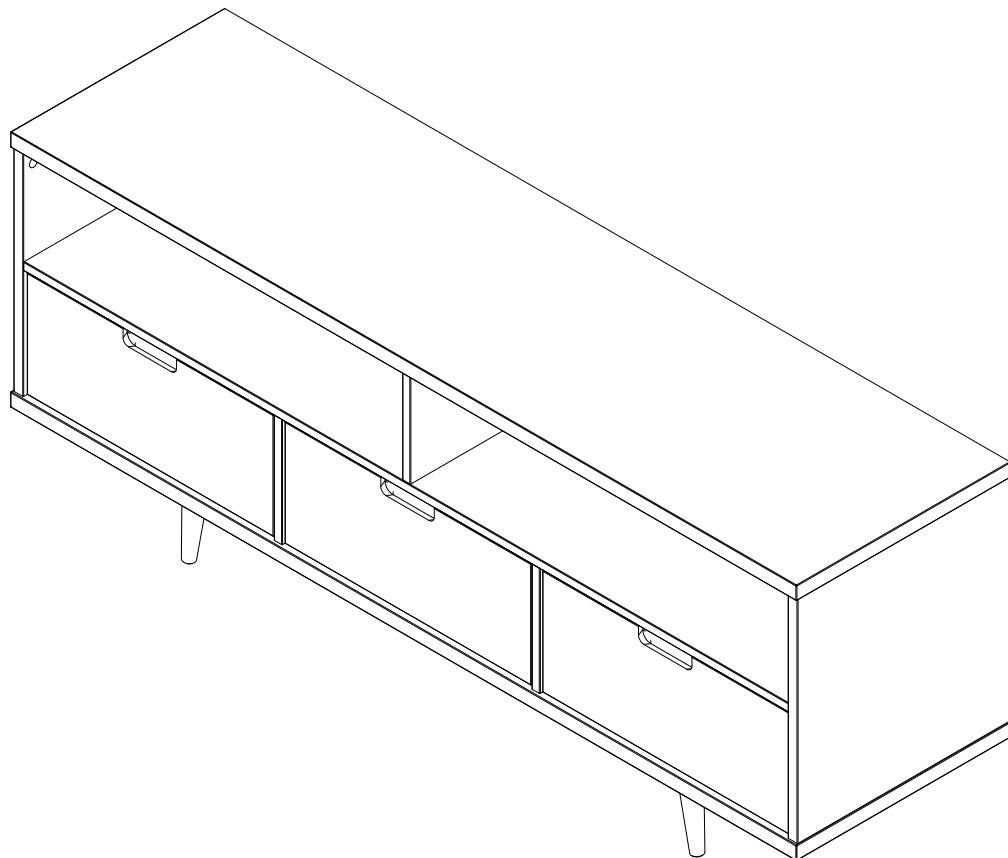
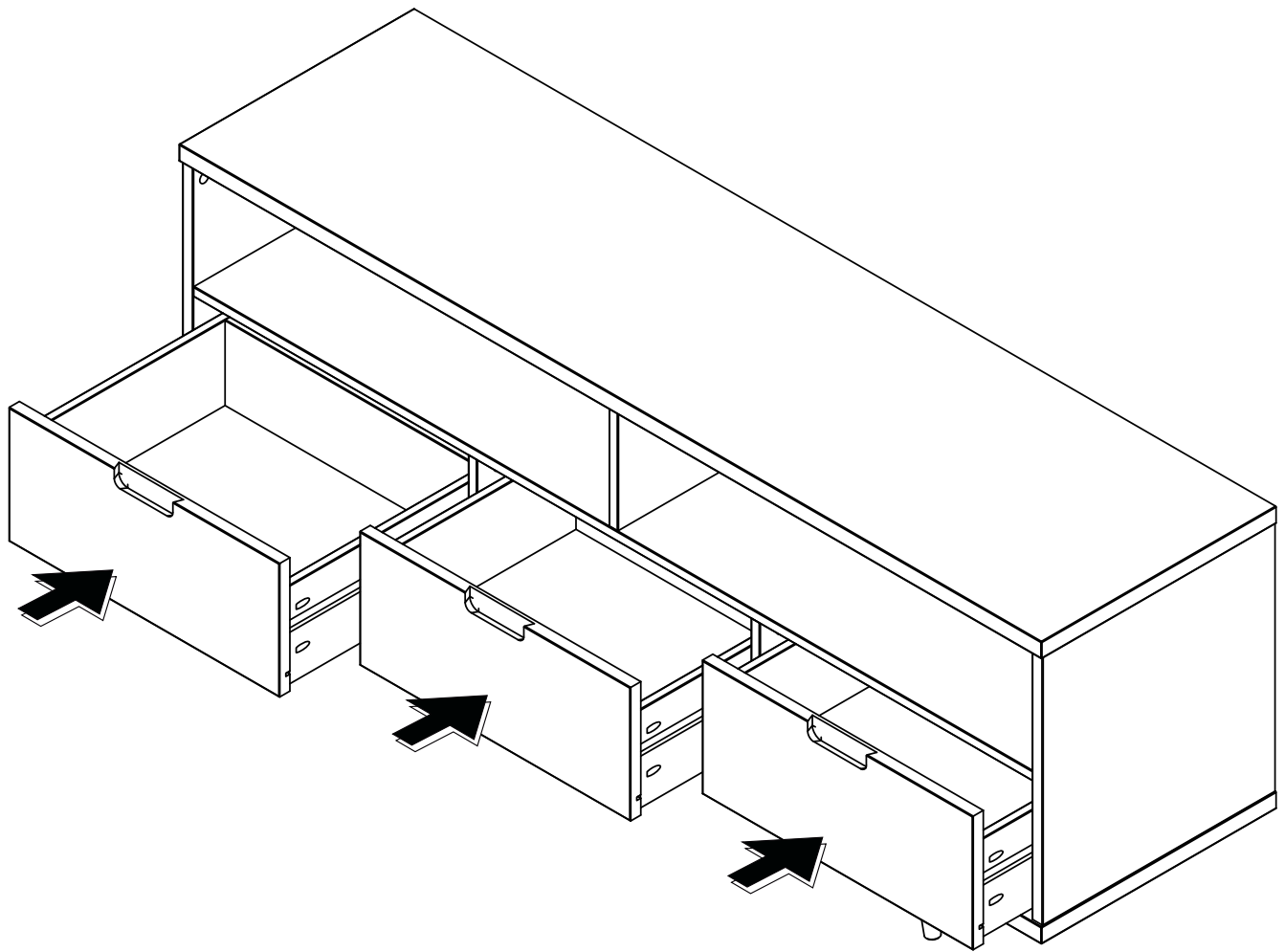

Final Assembly.