

OUTDOOR 4 PCS CONVERSATION SET ASSEMBLY INSTRUCTIONS

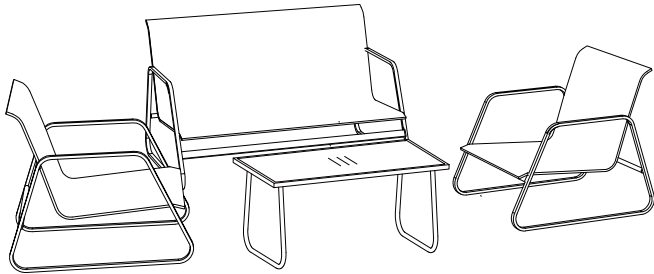





Assembly Instructions



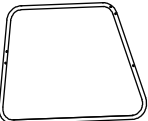
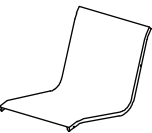
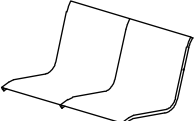

- Prior to assembly, ensure that you lay out and identify all the parts listed in the parts list.
- Tighten all nuts and bolts securely. Hand-tighten all bolts before use. Avoid using power tools or applying excessive force during assembly and bolt tightening.

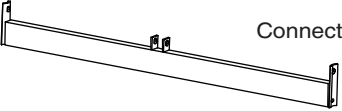
Care and warranty

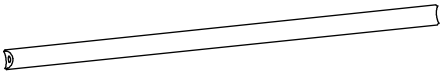

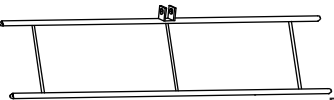

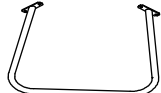



- The weight capacity of this single chair is 250 lbs and 500 lbs for loveseat.
- Clean the frame components and fabric with a mild soap solution, then rinse thoroughly. Avoid using bleach, acid, or any other solvents on either the fabric or frame components.
- For the best performance and safety of your chair, inspect and tighten all bolts and fasteners regularly

Part list

Part	Description	Qty
A	 Leg	6
B	 Singer Seat	2
C	 Double Seat	1
D	 Connecting bar	2
E	 Connecting bar	1
F	 Supporting bar	4
G	 Supporting bar	4

Part	Description	Qty
H	 Back Frame	1
I	 TableTop Frame	1
J	 Table Leg	2
K	 Top Glass	1

Hardware Bag

L	M	N	O
			
8 pcs	2 pcs	18 pcs	12 pcs
P	Q	R	S
			
18 pcs	54 pcs	1 pc	1 pc

SINGER CHAIR

(DO THIS TWICE)

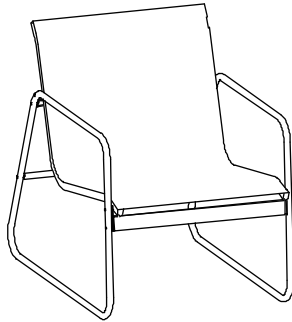

2. Place the single seat (Part B) onto the legs (Part A) as indicated in the diagram, securing it with bolt O, washer Q, plastic washer P, and a nut.

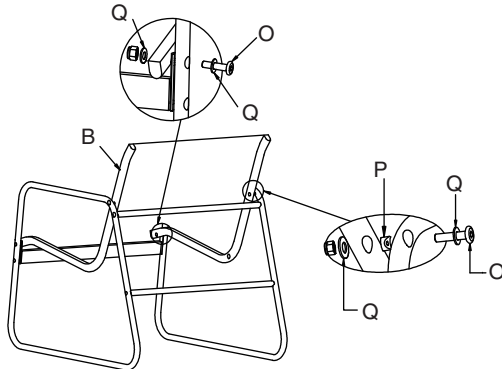

1. First, assemble the legs (Part A) by connecting the bar (Part D) using bolt N and washer Q. Then, separately attach the other two connecting bars (Part G) to the legs (Part A) using bolt N and washer Q.

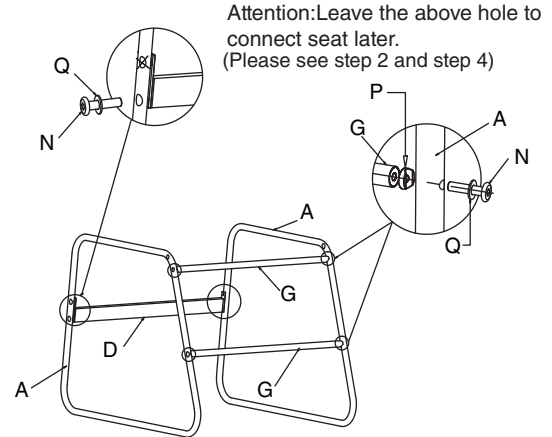

Attention: Leave the above hole to connect seat later. (Please see step 2 and step 4)

Attention:

1. Plastic washer (Part P) must be put between Part A and Part B.
2. Leave other side loose.

SINGER CHAIR

(DO THIS TWICE)

3. Attach the supporting bar (Part F) under the seat (Part B) as illustrated in the diagram.

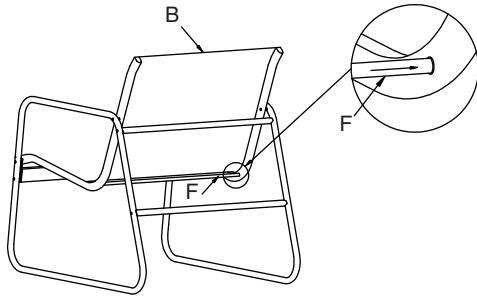

4. Connect the other side of the seat (Part B) to the leg (Part A) as depicted in the diagram, using bolt O, plastic washer P, washer Q, and a nut.

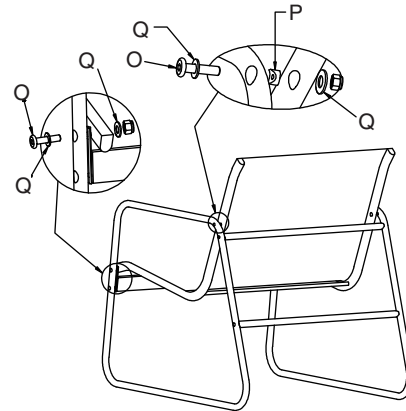

Attention: Washer (Part P) must be put between Leg (Part A) and Seat (Part B).

5. At the conclusion of the process, ensure that all nuts and bolts are securely tightened before using.

LOVESEAT

5. Attach double seat (Part C) to legs (Part A) using bolt O, washer Q, plastic washer P and nut as shown in diagram.

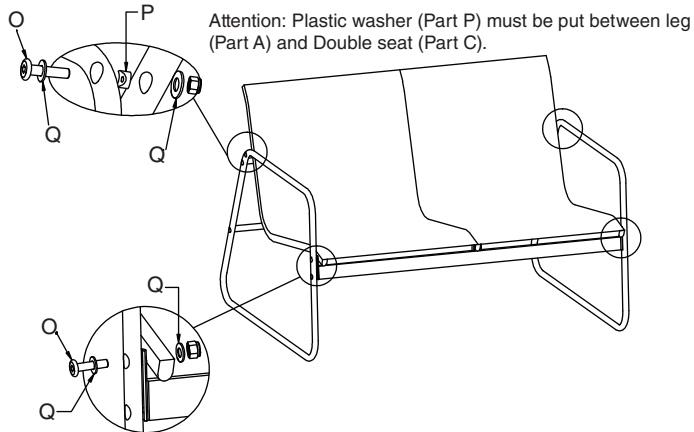

4. Insert supporting bar (Part F) to double seat (Part C) as shown in diagram.

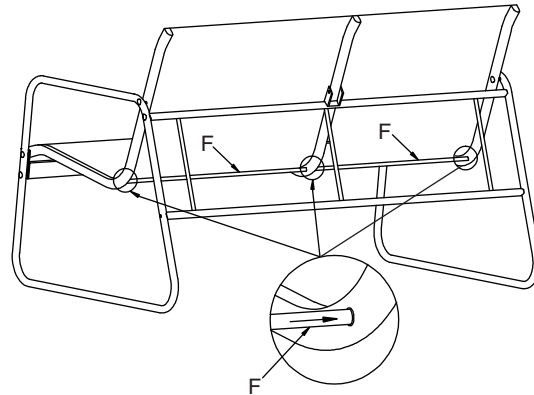

6. In the end, tighten all nuts and bolt securely before use.

COFFEE TABLE

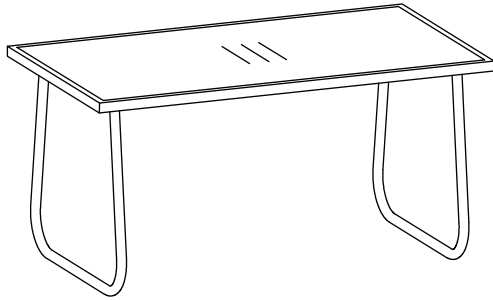

2. Put glass Part K on the Part I as shown in diagram.

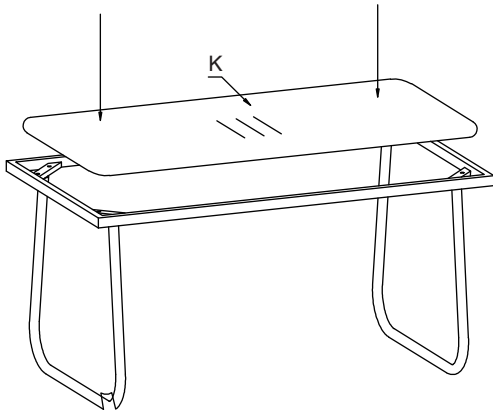

1. Attach table legs (Part J) to the table top frame (Part I) using bolt L, washer Q as shown in diagram.

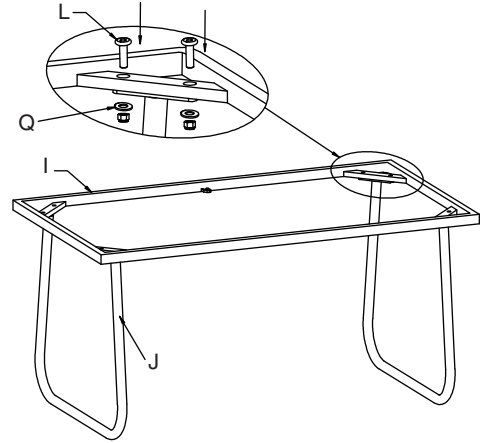

3. At the end of the process, tighten all nuts and bolts