

PL> INSTRUKCJA MONTAŻU
D >MONTAGEANLEITUNG
GB>ASSEMBLY INSTRUCTIONS
NL>HANDLEIDING VOOR DE MONTAGE
F >MODEL D'EMPLOI

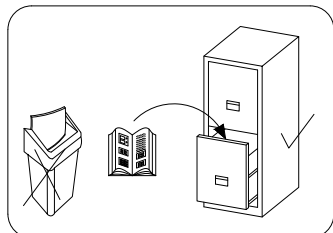

Czas montażu
 Montagezeit
 Time to assemble
 Montagetijd
 Temps de montage

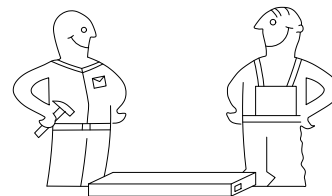

180 minut
 180 minuten
 180 minutes
 180 minuten
 180 minutes

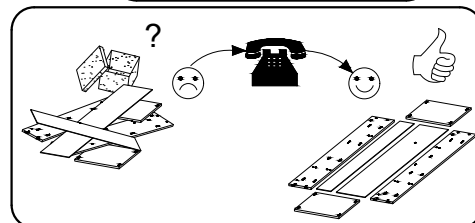
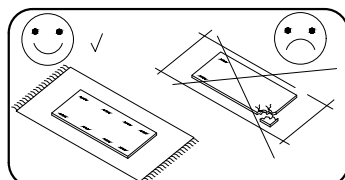
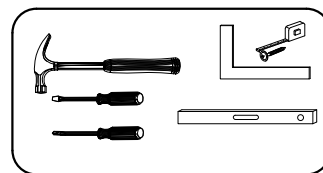

! Uwaga / Achtung / Caution / Opgelet / Attention !

PL>Czyszczenie należy wykonać wyłącznie za pomocą ściereczki lub lekko nawilżonego ręcznika.
 Nie stosować środków czyszczących do szorowania.

Szanowny kliencie, jeśli podczas montażu stwierdzisz uszkodzenie lub brak części, proszę podaj jej kod alfanumeryczny lub zaznacz ją na instrukcji montażu i prześlij wraz z protokołem reklamacyjnym

D >Bitte nur mit einem Staubtuch oder leicht feuchtem Lappen reinigen. Keine scheuerenden Putzmittel verwenden.

Sehr geehrter Kunde, sollte ein Teil fehlen oder beschädigt sein, kreuzen Sie dies bitte deutlich auf der Montageanleitung an und schicken Sie die Montageanleitung mit ein.

GB>Please only clean with a duster or a damp cloth. Do not use any abrasive cleaners.

Dear customer, should there be any piece missing or damaged, kindly mark this piece clearly on the attached assembly instructions and return them to us.

NL>Reinig alleen met een stofdoek of een lichtjes vochtige doek. Gebruik geen schurende poetsmiddelen.

Geachte klant, in het geval van beschadiging of ontbrekende onderdelen tijdens de montage, gelieve de alfanumerieke code in de montagehandleiding te vermelden of te markeren en samen met het klachtenprotocol mee te sturen

F >Le nettoyage se fait uniquement à l'aide d'un torchon ou d'une serviette légèrement mouillée.

Cher client, en cas de dommages ou de pièces manquantes lors du montage, veuillez fournir ou marquer le code alphanumérique dans le manuel de montage et l'envoyer avec le protocole de réclamation

Karta serwisowa / Service Karte / Service card / Service kaart / Carte de service

AKCESORIA / ZUBEHÖR / ACCESSORIES / ACCESSOIRES / ACCESSOIRES

 8.0x35 D 20	 4.0x25 G 4	 Y 20	 A 38	 B 38	 3.5x16 H 28	 V 20	 N 4	 K2 4	 K1 4	 S3 16
 X 30	 F 2	 S 38	 S1 80	 I 30	 L-775 V1 2	 L-1850 L 1	 6.3x13 Q 8	 J 10	 PD 4	 H4 20

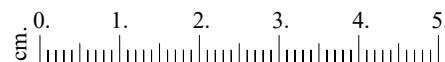

No.	Pcs.	L	W	D
1.	1	2000	620	16
2.	1	2000	620	16
3.	1	1888	480	16
4.	1	1768	582	16
5.	1	1768	600	16
6.	4	475	480	16
7.	1	1888	480	16
8.	4	475	480	16
9.	2	1768	80	16
10.	2	1918	492	3
11.	1	785	480	16
12.	1	1768	70	16
13.	2	1918	398	3
14.	1	1873	900	16
15.	1	1873	900	16

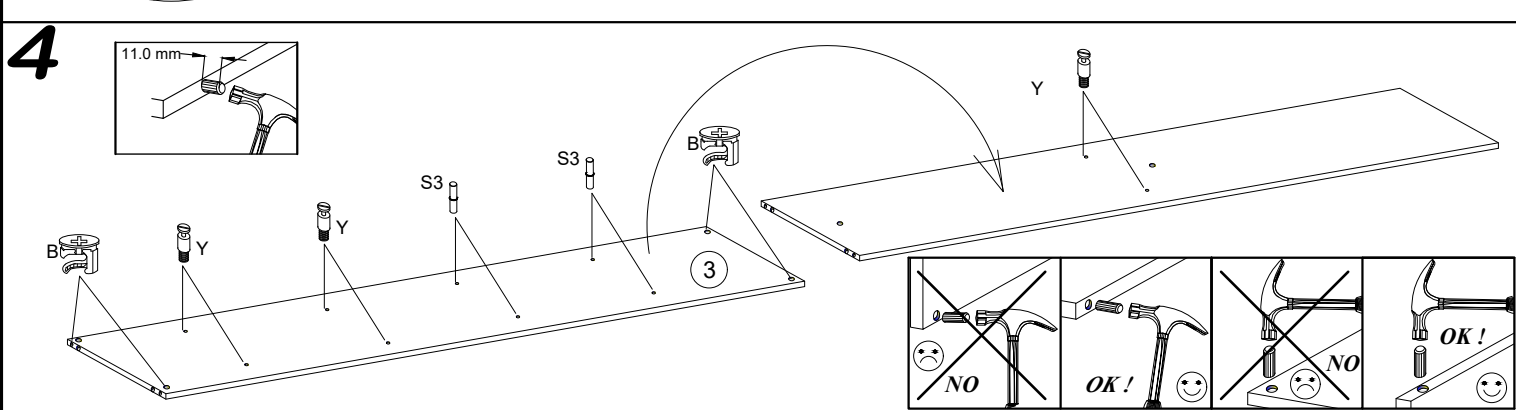
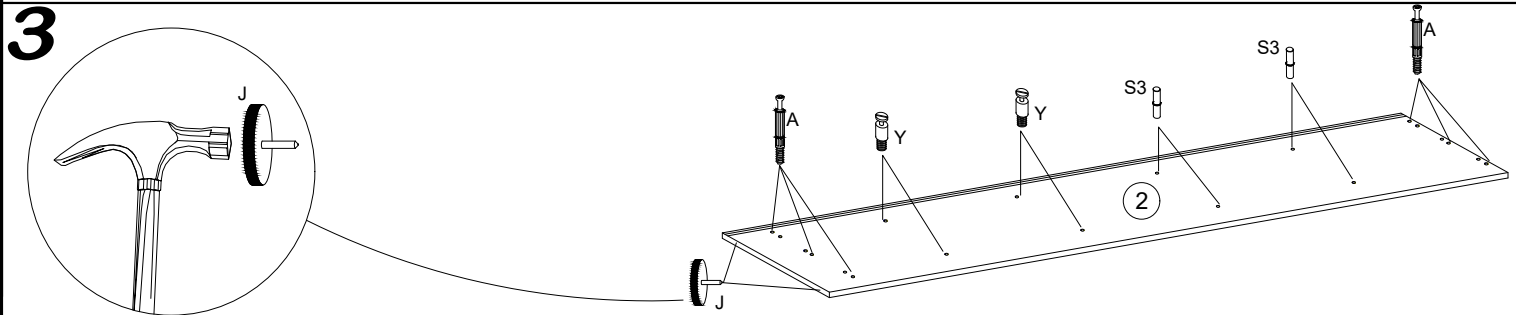
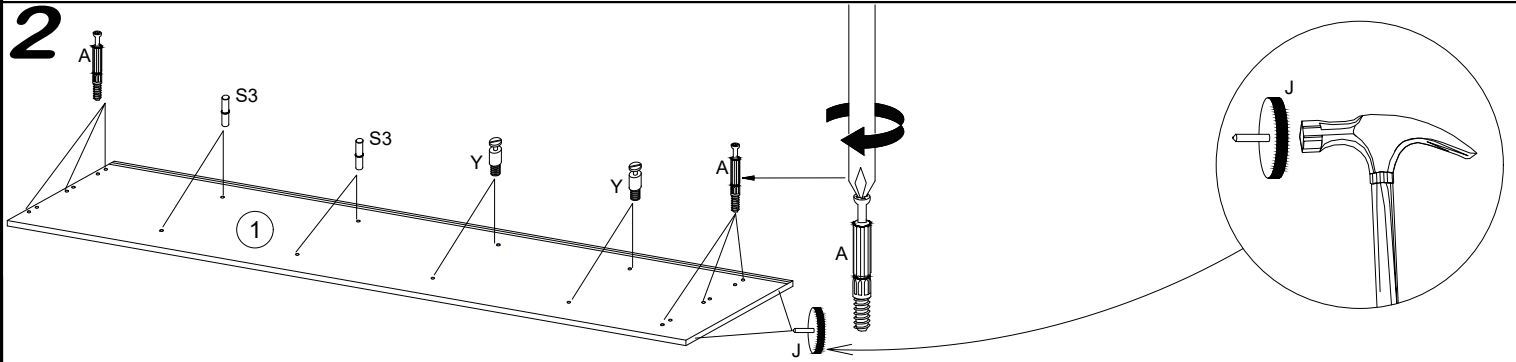
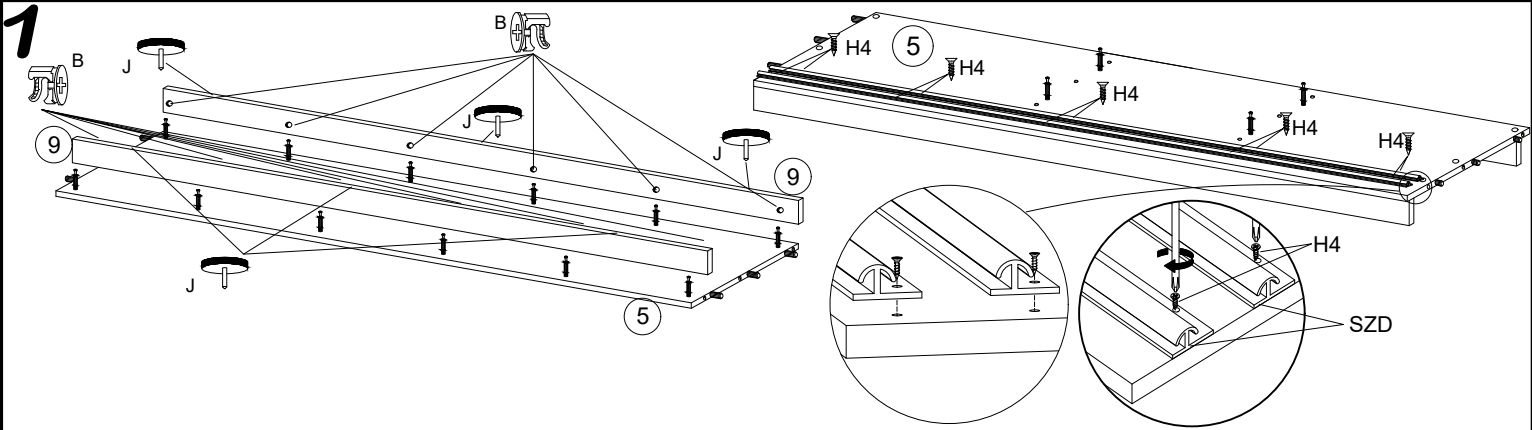
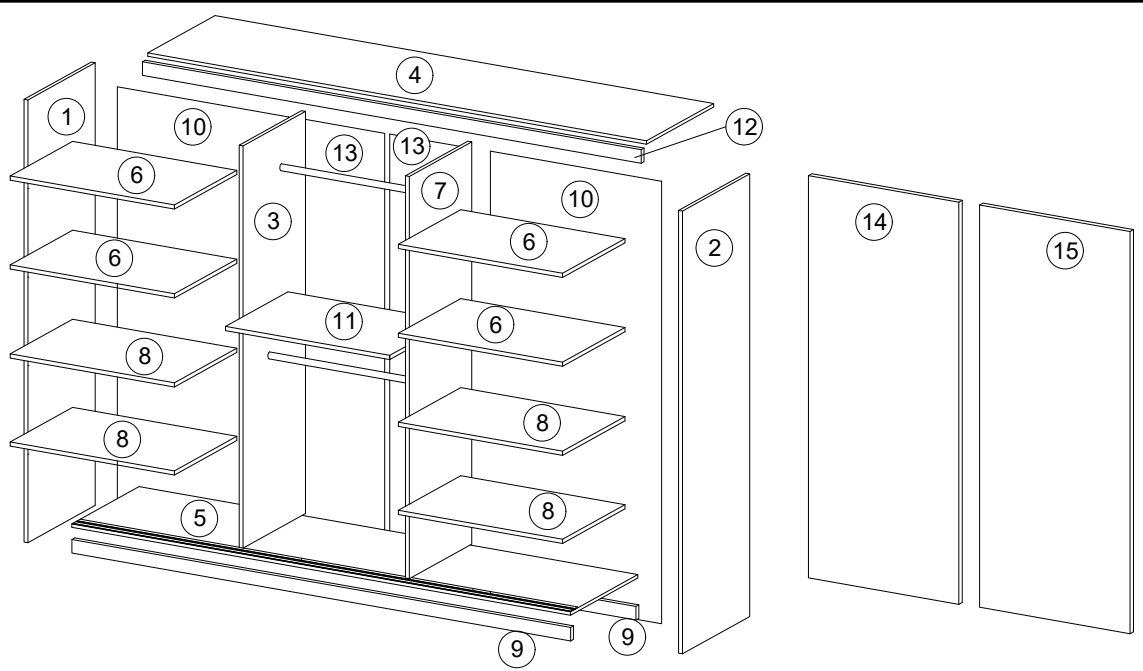

11

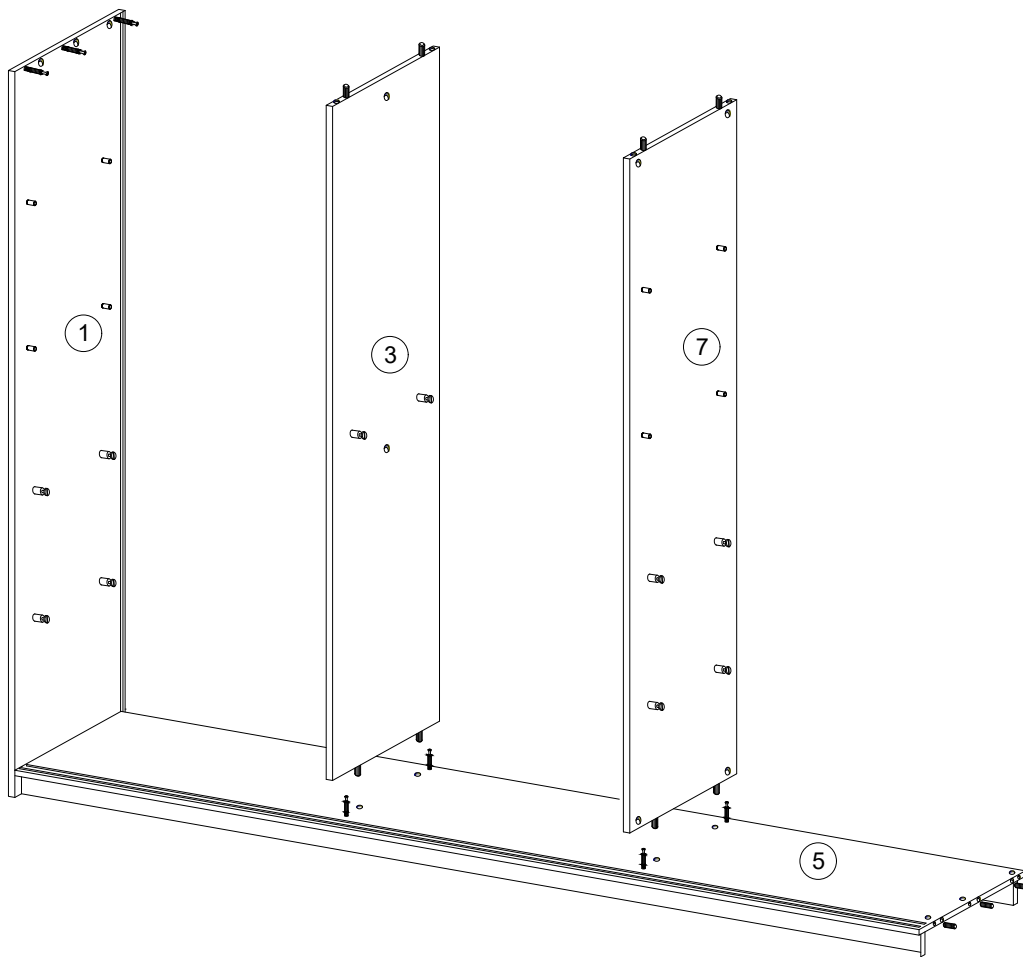

12

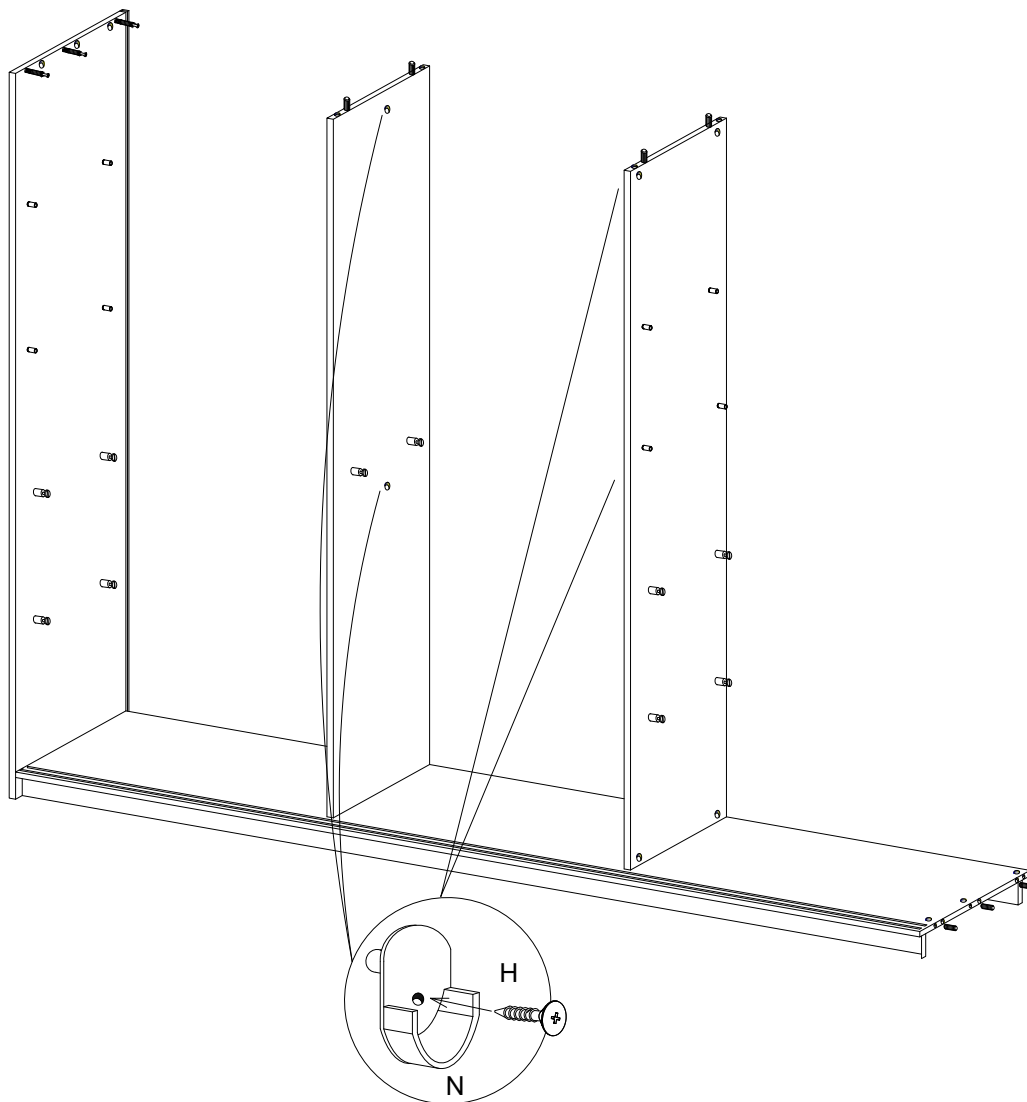

13

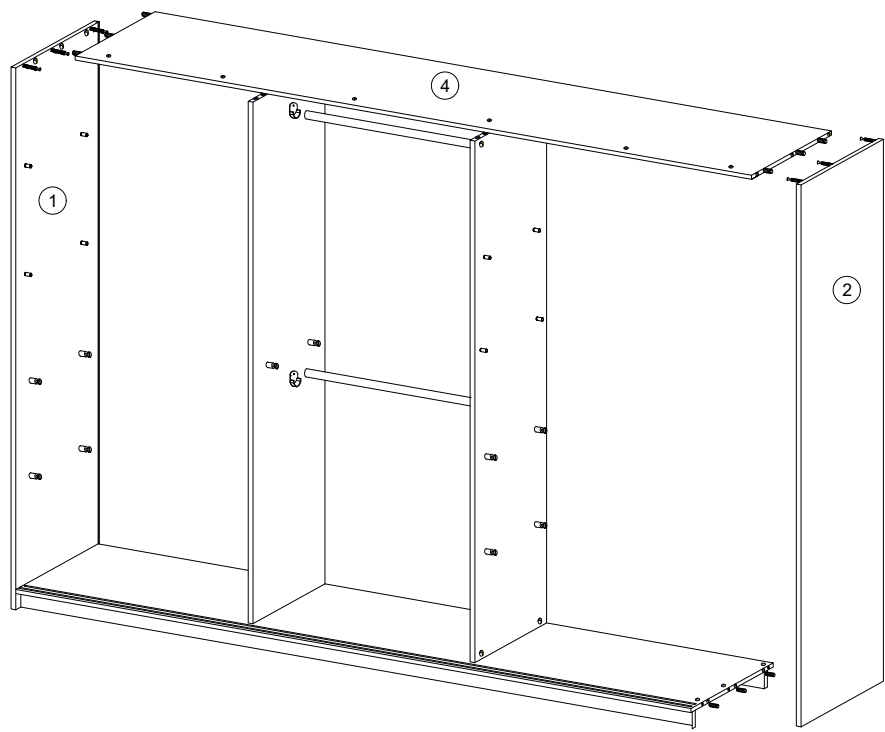

14

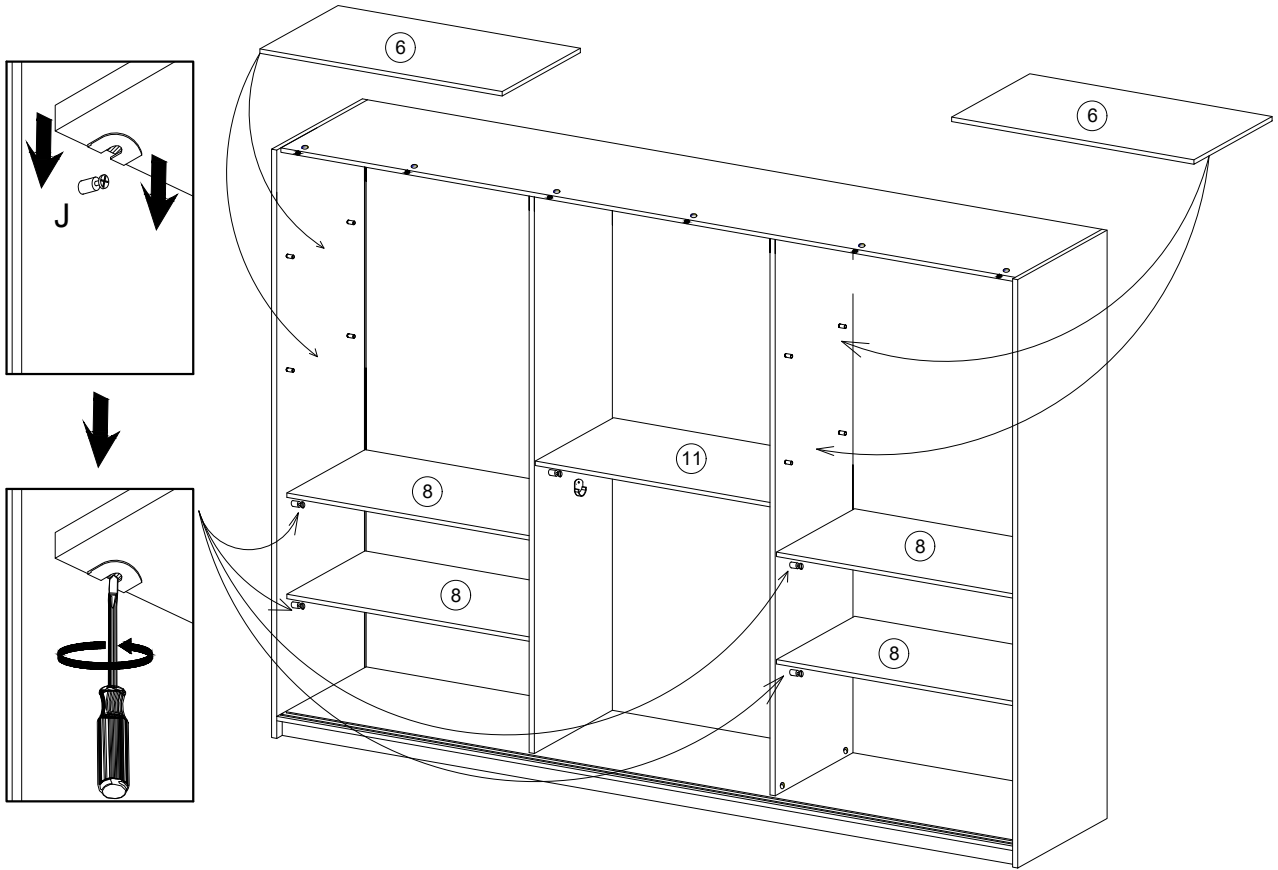

15

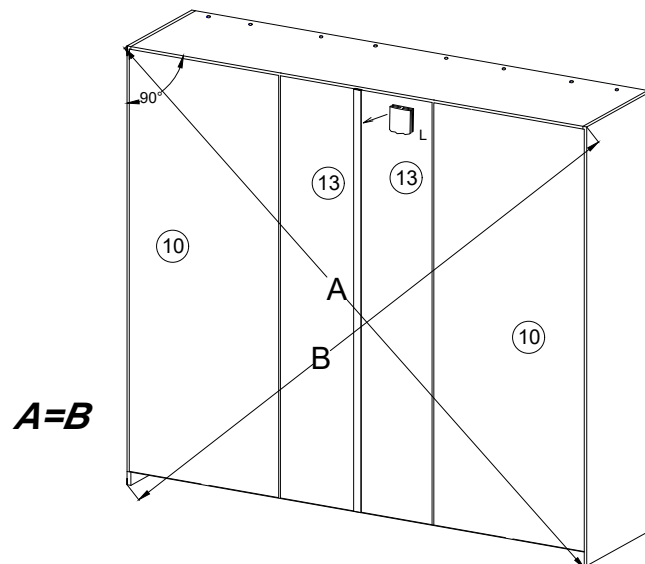

16

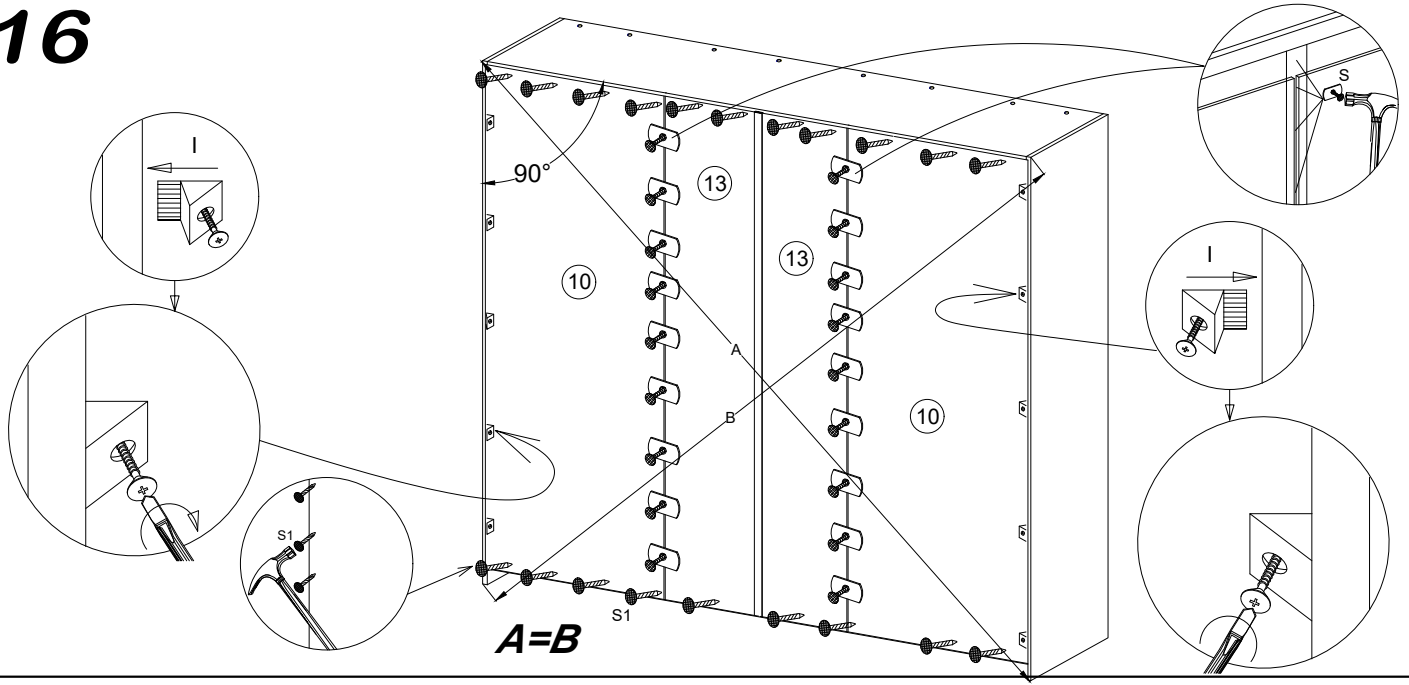

17

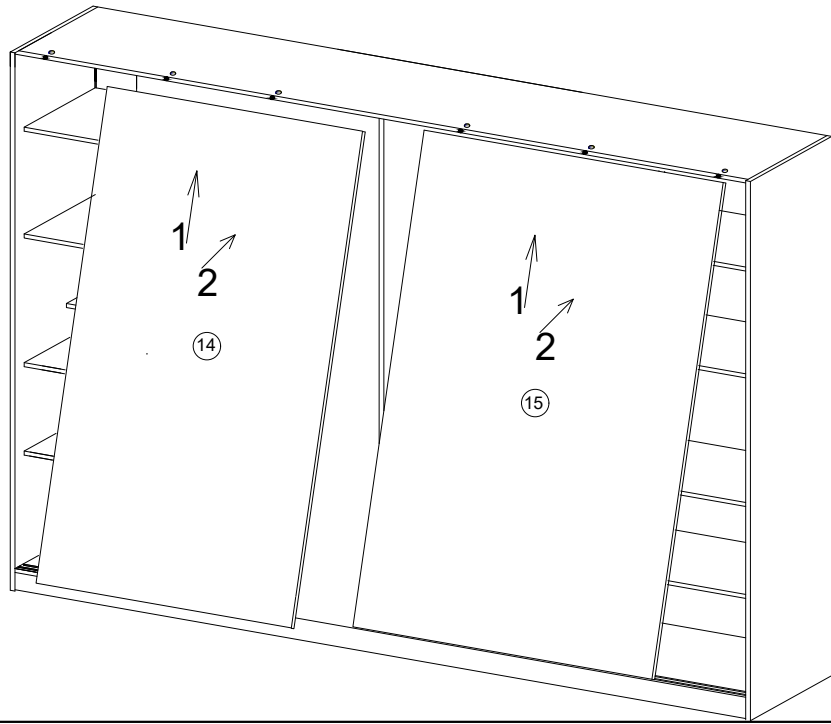

18

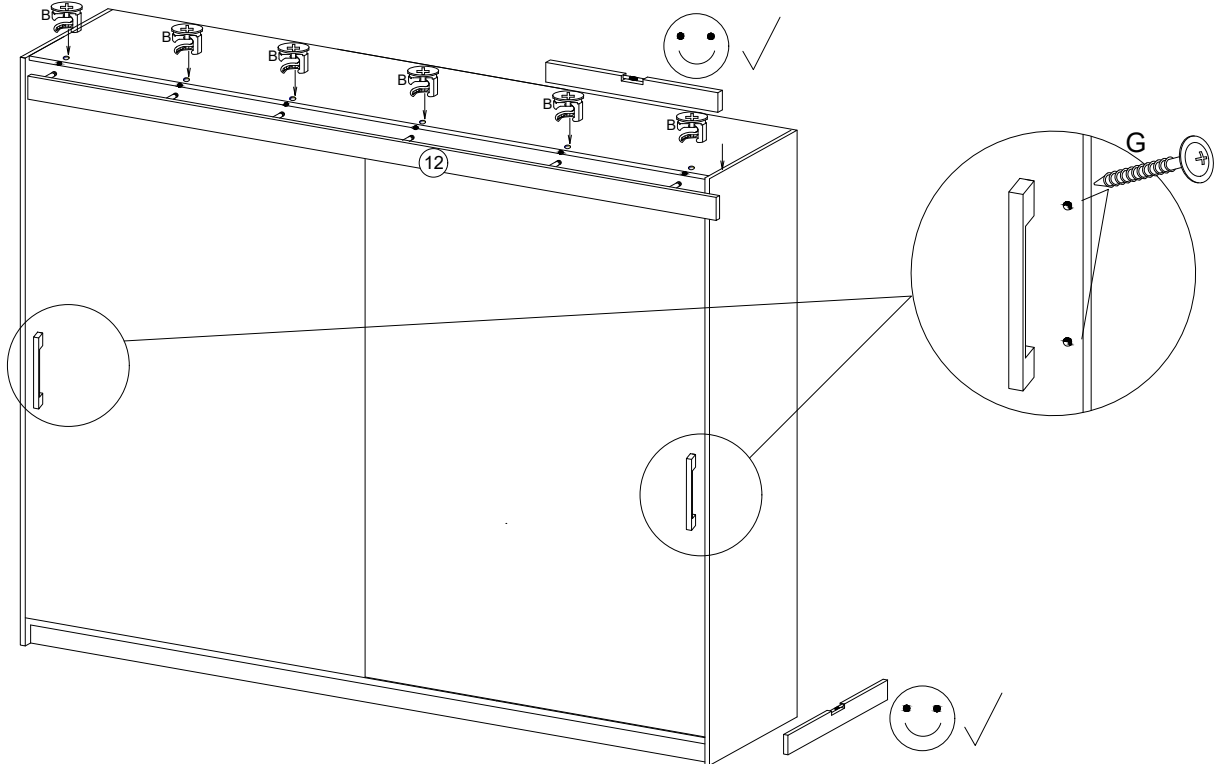

16

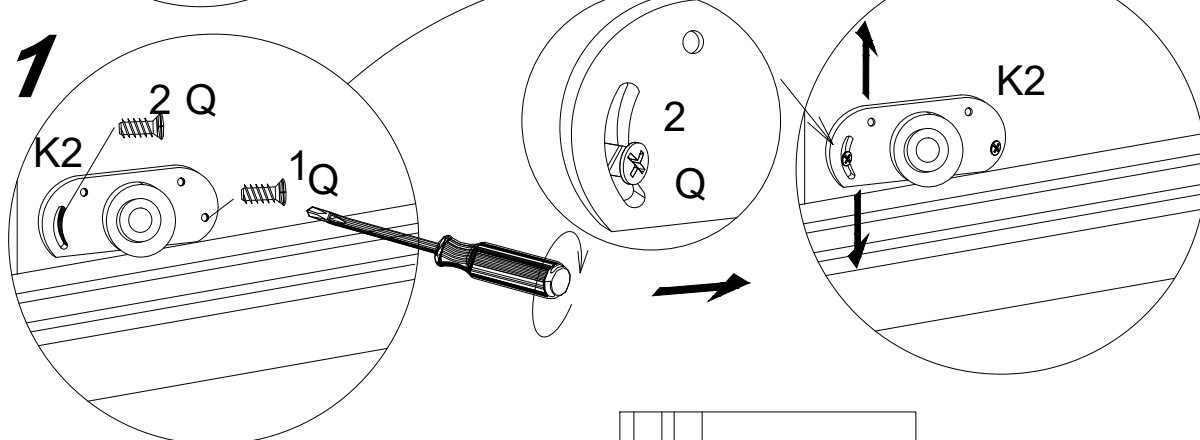
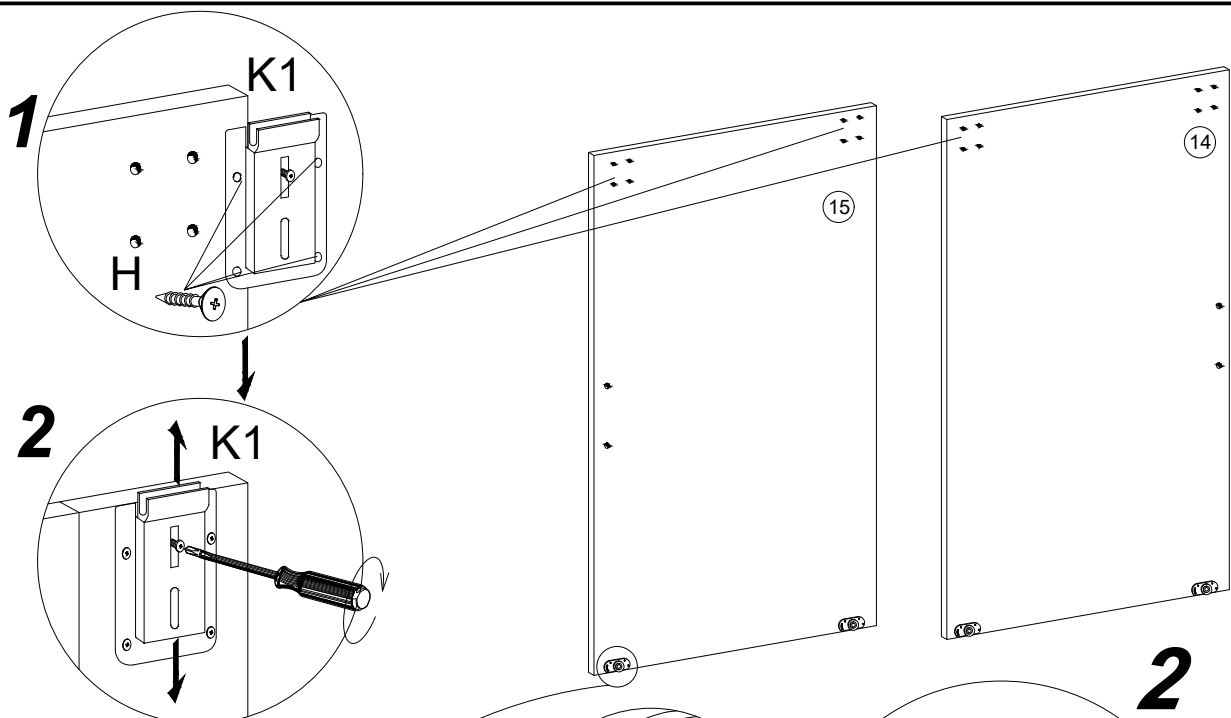

PL> PO WYREGULOWANIU DRZWI WKREĆCIĆ WKREĆCIE NR 3
D >NACH EINSTELLUNG DER TÜR SCHRAUBE NR. 3 EINSETZEN
GB>AFTER ADJUSTING THE DOOR, USE SCREW NO 3
NL>NA HET AFSTELLEN VAN DE DEUR, PLAATS SCHROEF NO.3
F >APRÈS LE RÉGLAGE DE LA PORTE, INSÉRER LA VIS N°3

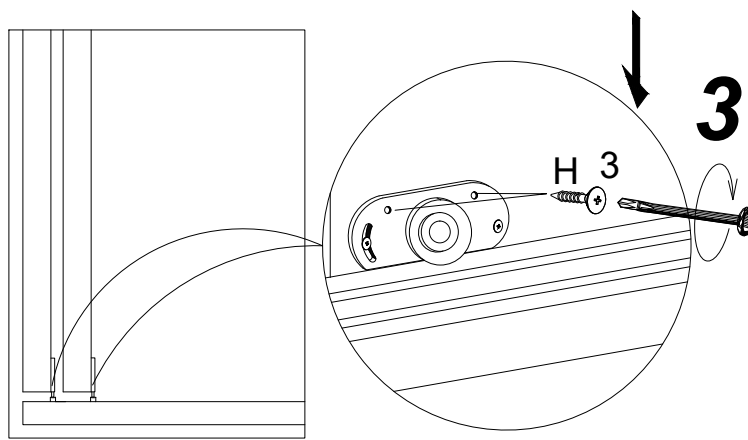

1

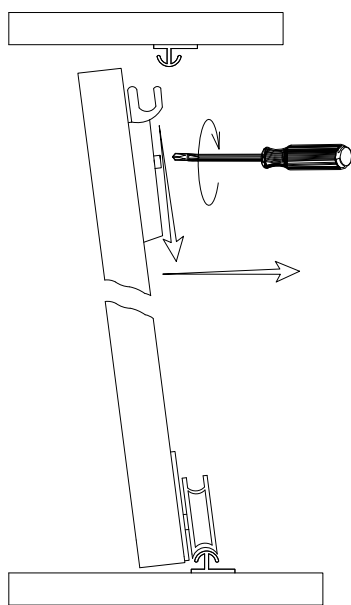

2

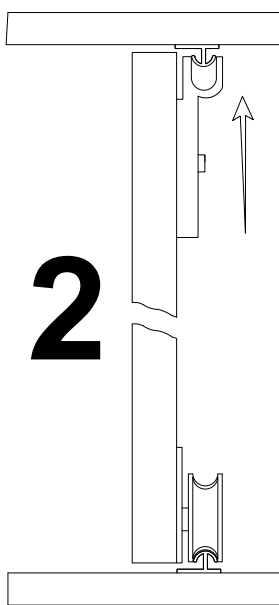

3

