

ASSEMBLY INSTRUCTIONS

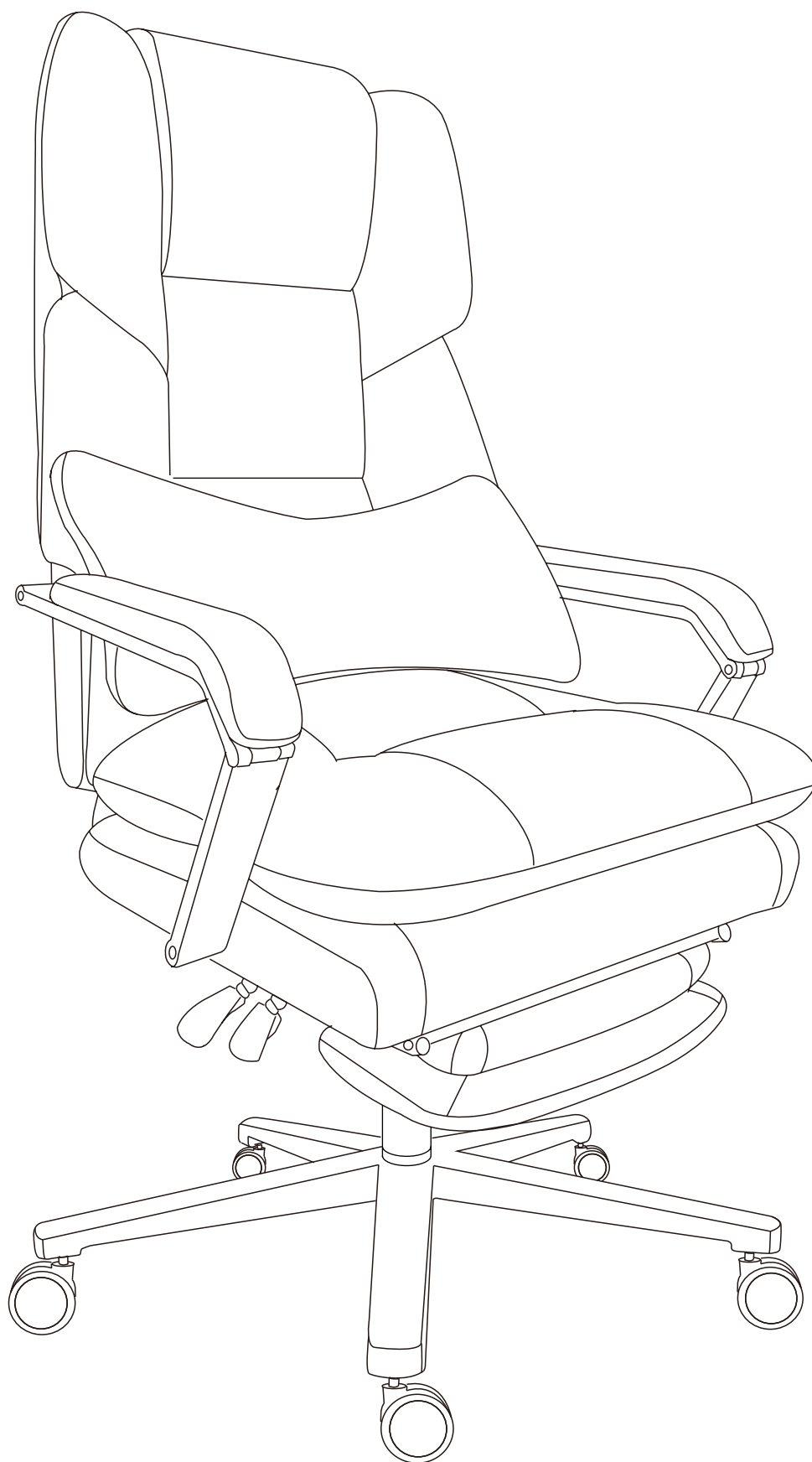

If you find any missing parts, please let us know, and we will send them to you as soon as possible.

Wenn Sie fehlende Teile feststellen, lassen Sie es uns bitte wissen, und wir werden sie Ihnen so schnell wie möglich zusenden.

<p>A</p> 	<p>B</p> 	<p>C</p> 
<p>D</p> 	<p>E</p> 	<p>F</p> 
<p>G</p> 	<p>H</p> 	<p>J</p> 
<p>K</p>  <p>X5</p>	<p>L</p>  <p>X4</p>	<p>M</p>  <p>X2</p>
<p>N M6*25MM</p>  <p>X12</p>	<p>O M8*20MM</p>  <p>X4</p>	<p>P M8*60MM</p>  <p>X4</p>
<p>Q M6*10MM</p>  <p>X2</p>	<p>R</p> 	

4.

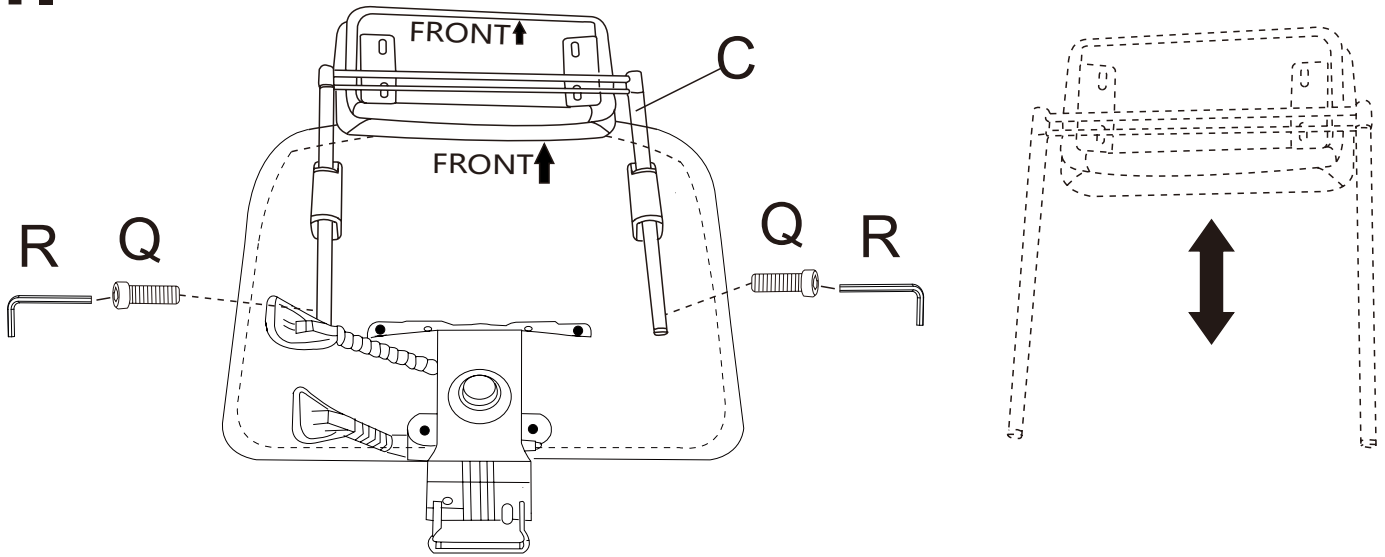

5.

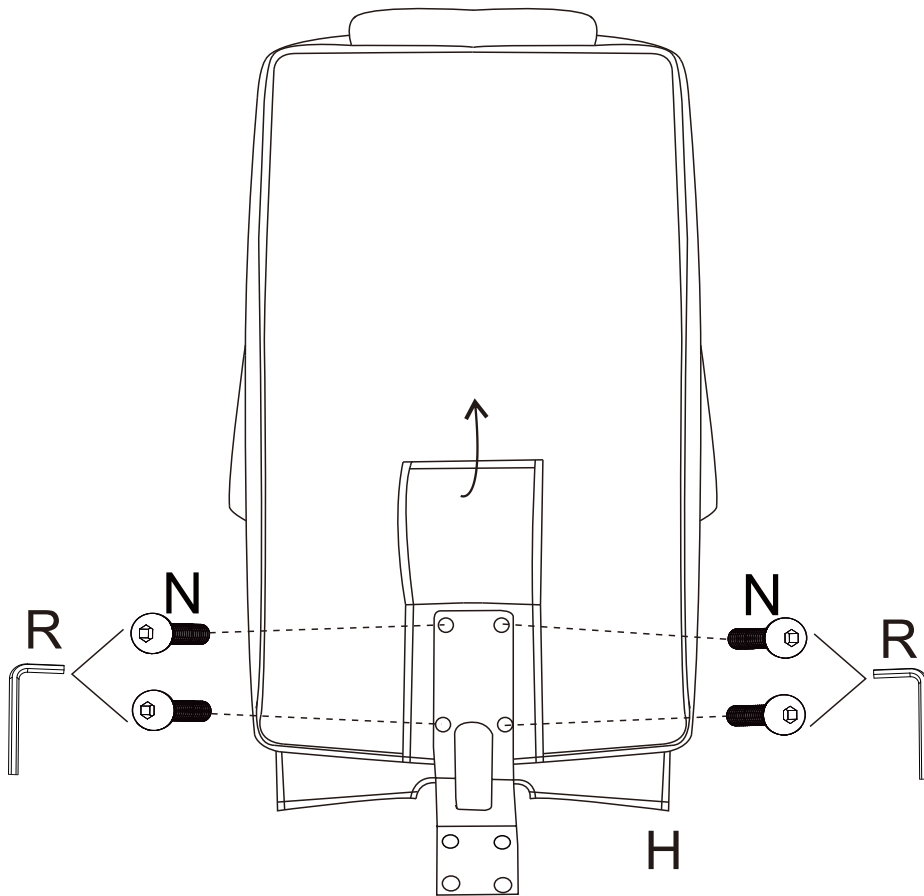

6.

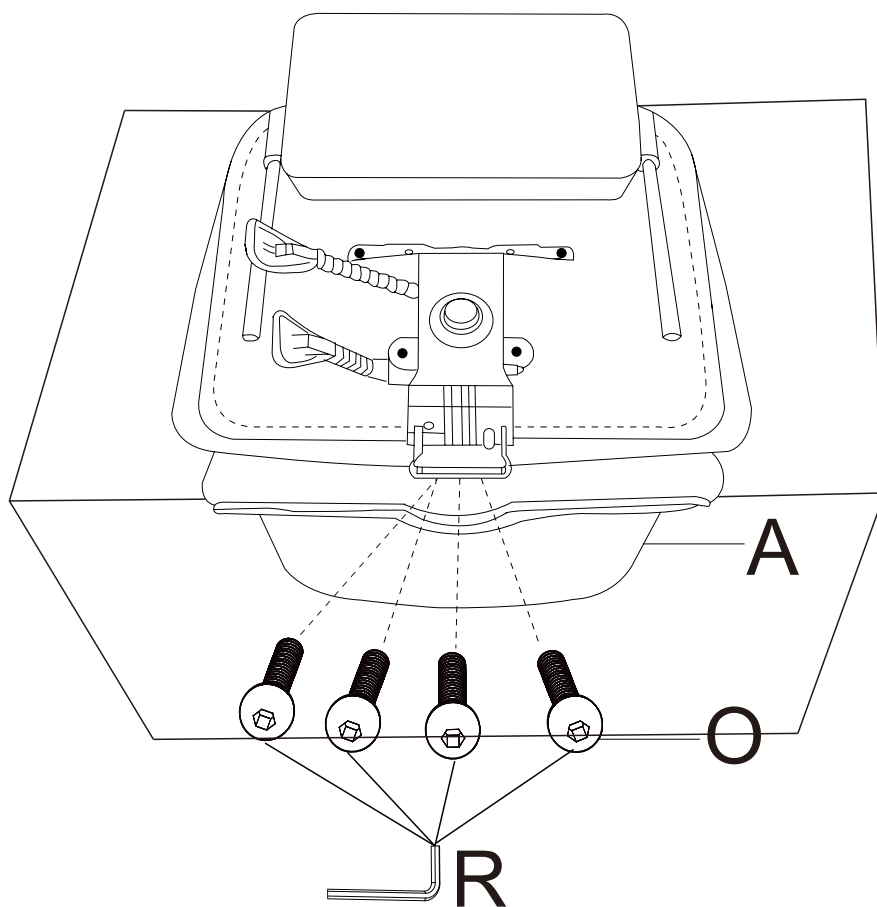

7.

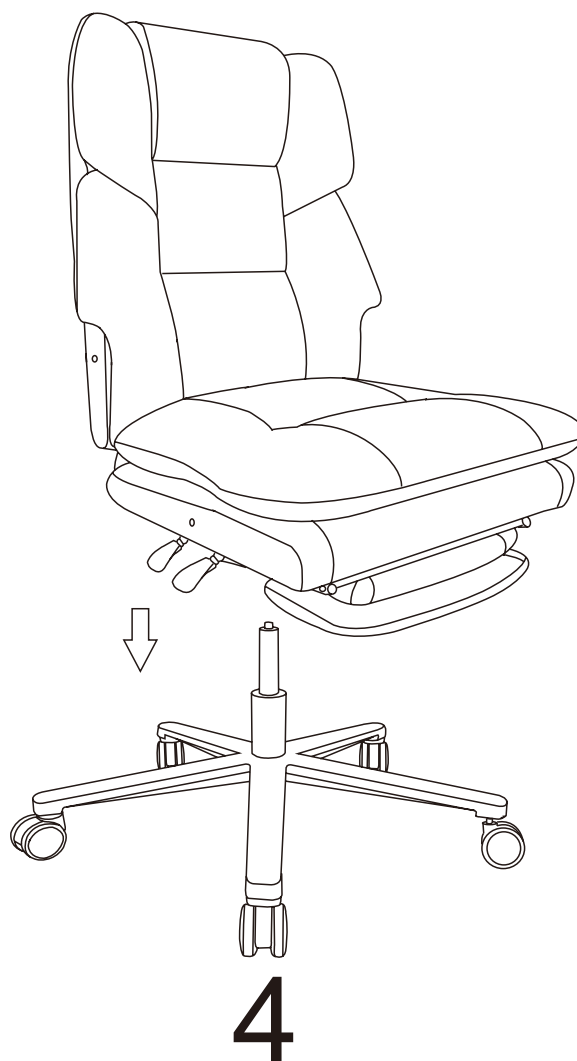

8.

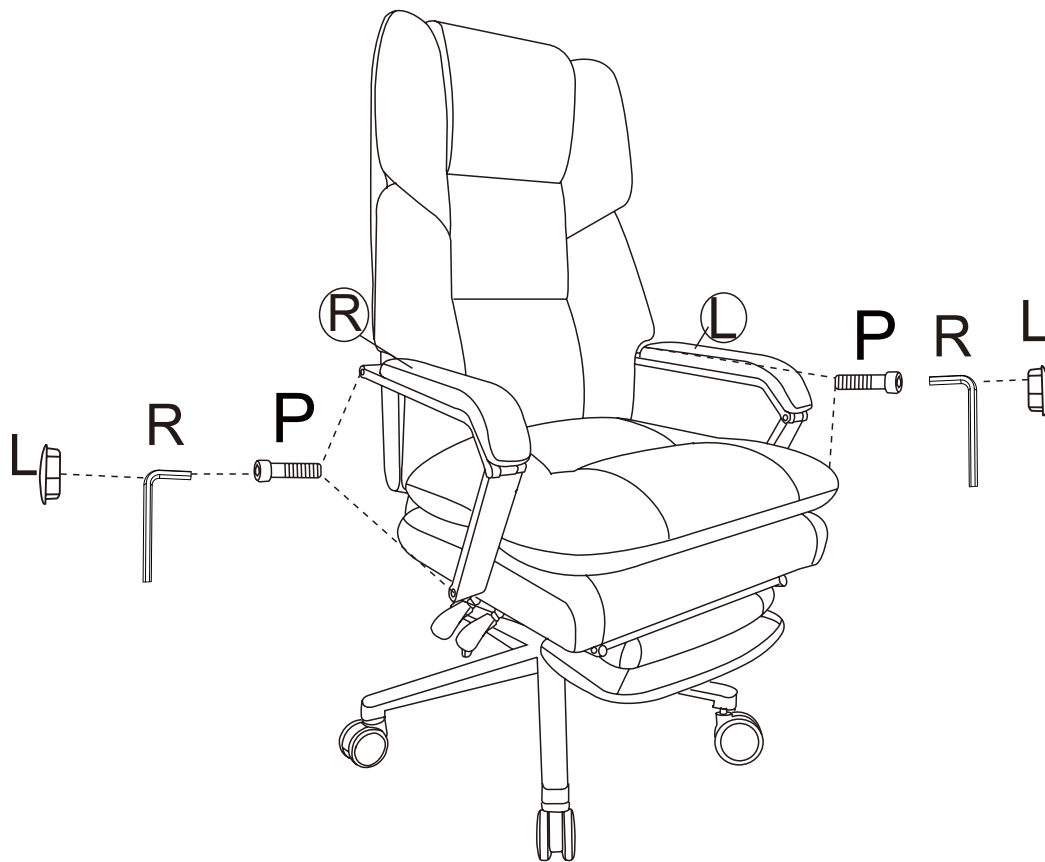

9.

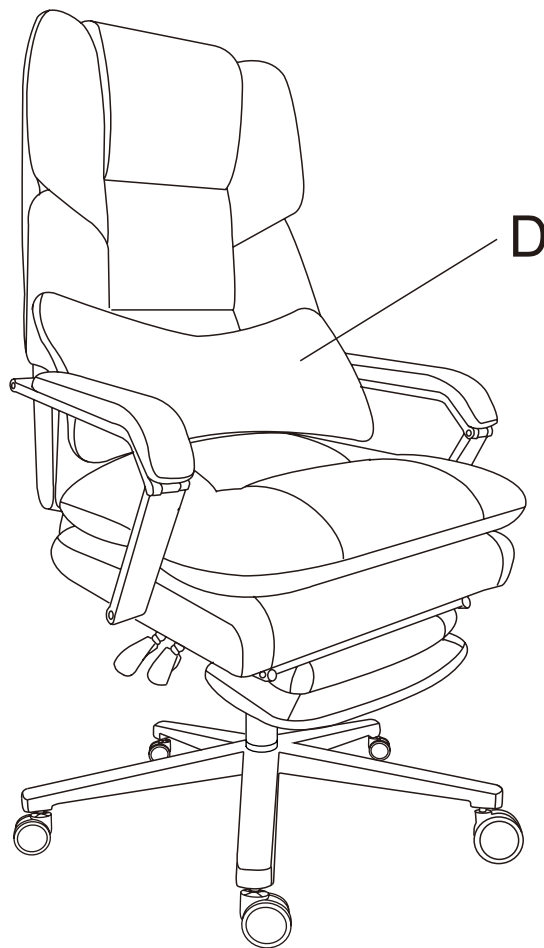

Function

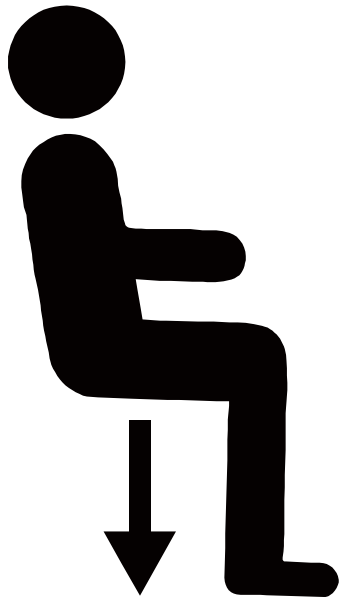

Load capacity up to 500lb
Tragfähigkeit bis zu 500 lb



360 degree swivel
360-Grad-Schwenk

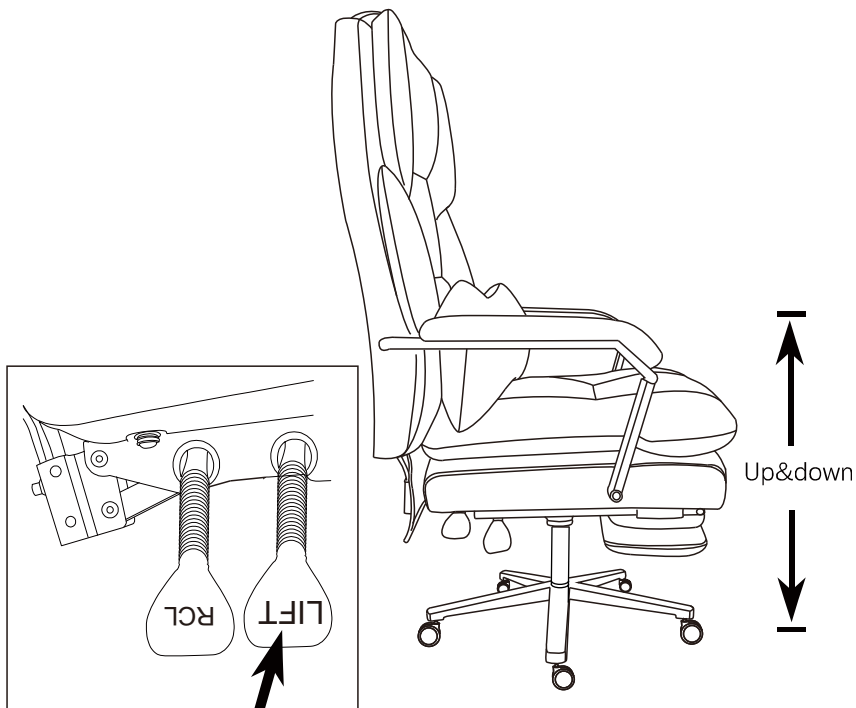

Seat Height adjustment (pull up on the
control handle to adjust)
Sitzhöhenverstellung (Bedienhebel zum
Einstellen nach oben ziehen)

Reclining function

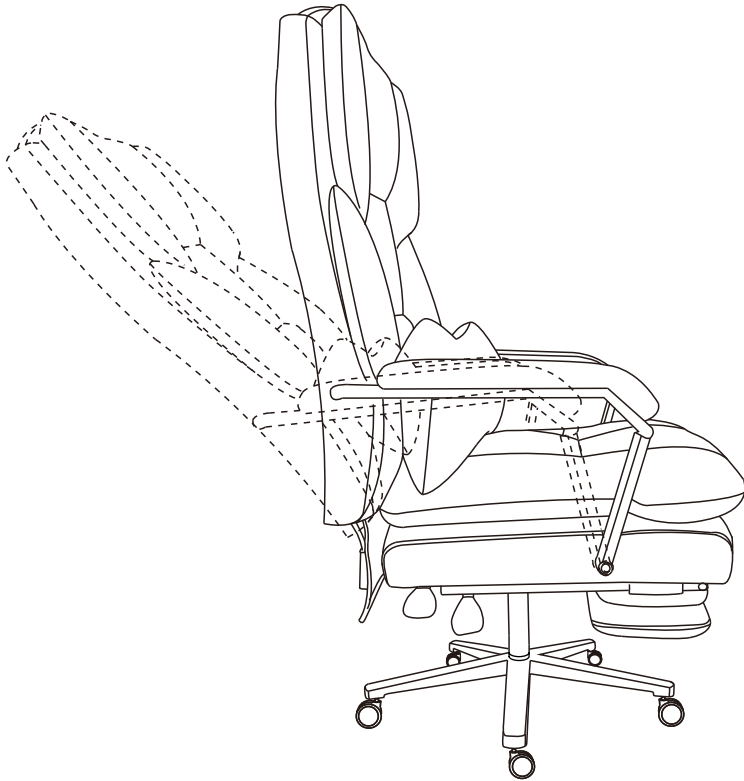

pull up on the rear control handle to adjust the reclining angle

Ziehen Sie den hinteren Bedienungsgriff hoch, um den Neigungswinkel einzustellen

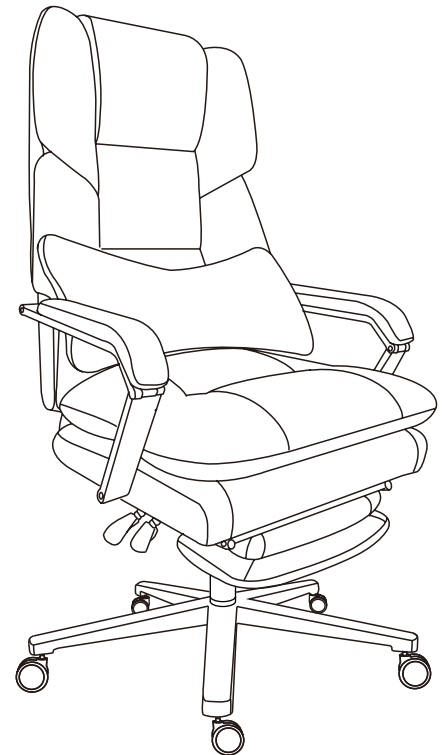

pull down it to fix the backrest of the chair at the angle

Ziehen Sie den hinteren Griff nach unten, um die Rückenlehne des Stuhls im gewünschten Winkel zu arretieren.

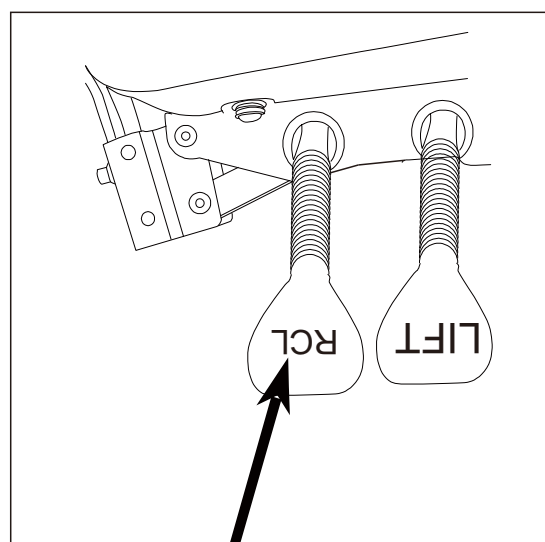

Adjustable degree : 90°-135°
Einstellbarer Neigungswinkel : 90°-135°

Instructions during use

1. Move the item gently to avoid collision.
2. Keep it away from direct sunlight.
3. Check to ensure that the center of gravity is on the hydraulic when in use.
4. Watch out your fingers when adjusting the backrest angle.
5. Use the handle adjuster under the seat to adjust the seat height. Do not press or pull the seat by force.
6. Do not place any heavy objects on the seat or armrests.
7. Keep the plastic parts away from direct sunlight.
8. Avoid abrasive cleaner for cleaning.

1. Bewegen Sie den Gegenstand behutsam, um Zusammenstöße zu vermeiden.
2. Vor direkter Sonneneinstrahlung schützen.
3. Stellen Sie sicher, dass der Schwerpunkt während der Nutzung auf dem Hydrauliksystem liegt.
4. Achten Sie auf Ihre Finger bei der Einstellung des Rückenlehnenwinkels.
5. Verwenden Sie den Verstellhebel unter dem Sitz, um die Sitzhöhe einzustellen. Drücken oder ziehen Sie den Sitz nicht mit Gewalt.
6. Keine schweren Gegenstände auf Sitzfläche oder Armlehnen abstellen.
7. Kunststoffteile vor direkter Sonneneinstrahlung fernhalten.
8. Reinigung mit scheuernden Mitteln vermeiden.