

Assembly Instructions

CHAIR

CAUTION: You should read this before you proceed

Please look in the Seat Panel for hardware packs

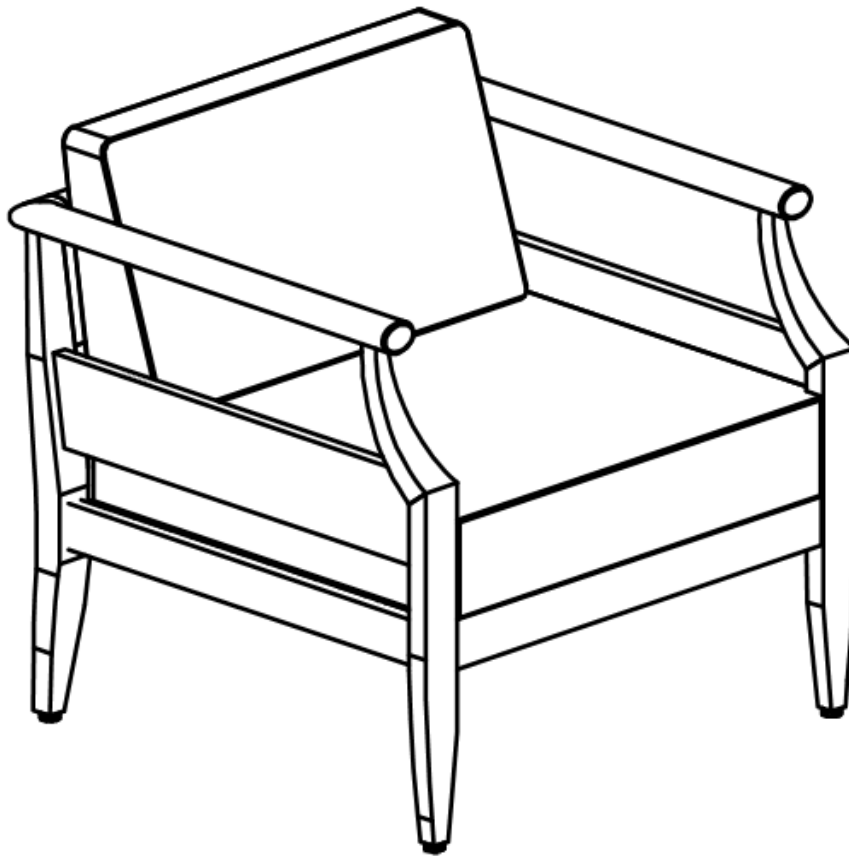



CAUTION: This Chair is NOT a TOY.



Keep your child / children at bay during the process of assembly.

For turning the Chair and to prevent damage to the Chair, 02 persons may be needed to execute this action.

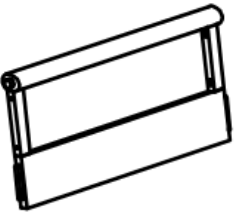
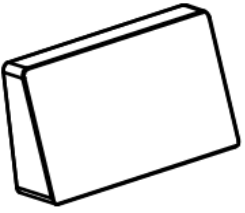
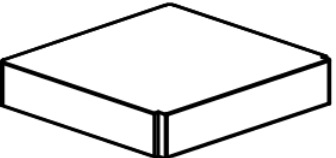
Parts List

Label	Picture	Description	Qty
A		Left Leg Panel With Pre-installed Levellers	1
B		Right Leg Panel With Pre-installed Levellers	1
C		Seat Panel	1
D		Backrest Panel	1
E		Back Cushion	1
F		Seat Cushion	1

Hardware

Label	Picture	Description	Qty
①		Bolt (M6*50mm)	9
②		Allen Wrench	2

Assembly Preparation

Before Beginning Assembly:

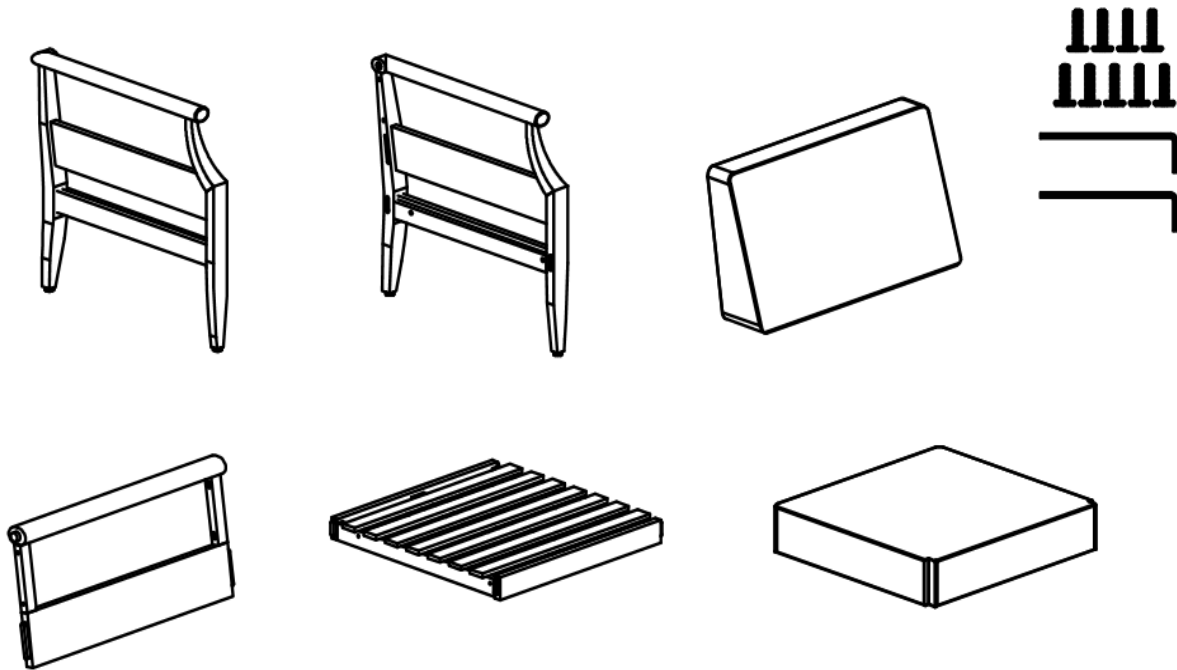

• Read instruction, cover to cover-



• Have 2 adults on hand for assembly-



• Do not assembly on flooring or carpet-



• Assemble on a cleana non- marring surface (packing foam)-



• Save all packaging until finished-

Assembly Steps

OVERVIEW

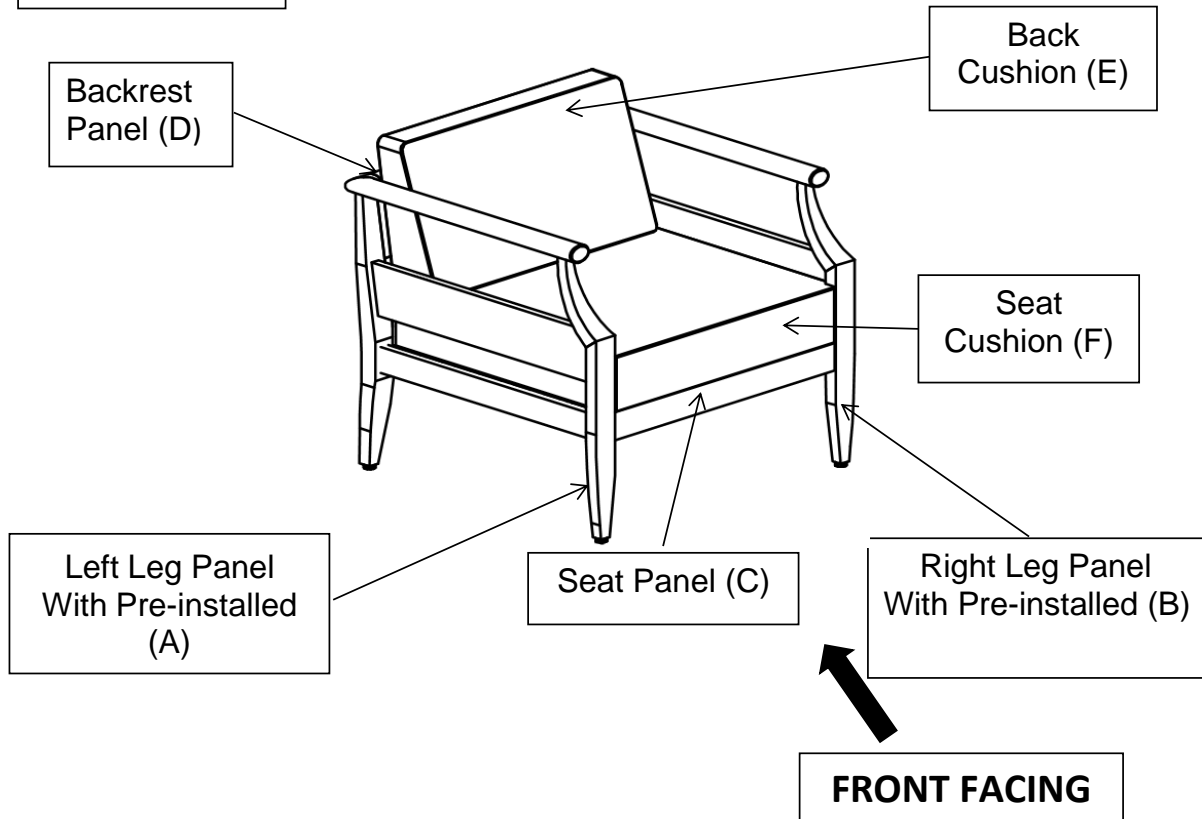

This Chair has multiple parts and may require up to some 30 minutes to assemble.

To give you an overview of the Chair, the above picture is to help you put the various parts into perspective. Please read through the instructions here below to familiarise yourself with the parts and steps before assembly.

Step 1

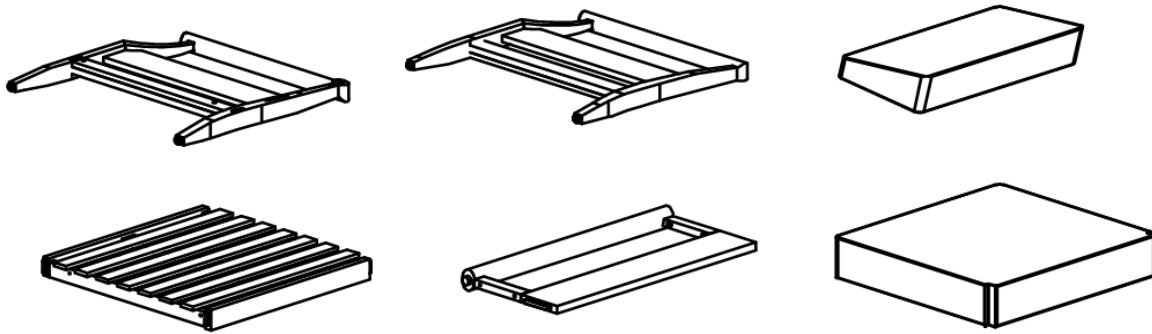

Unpack and place all parts on a clean, non-marring surface.

Step 2

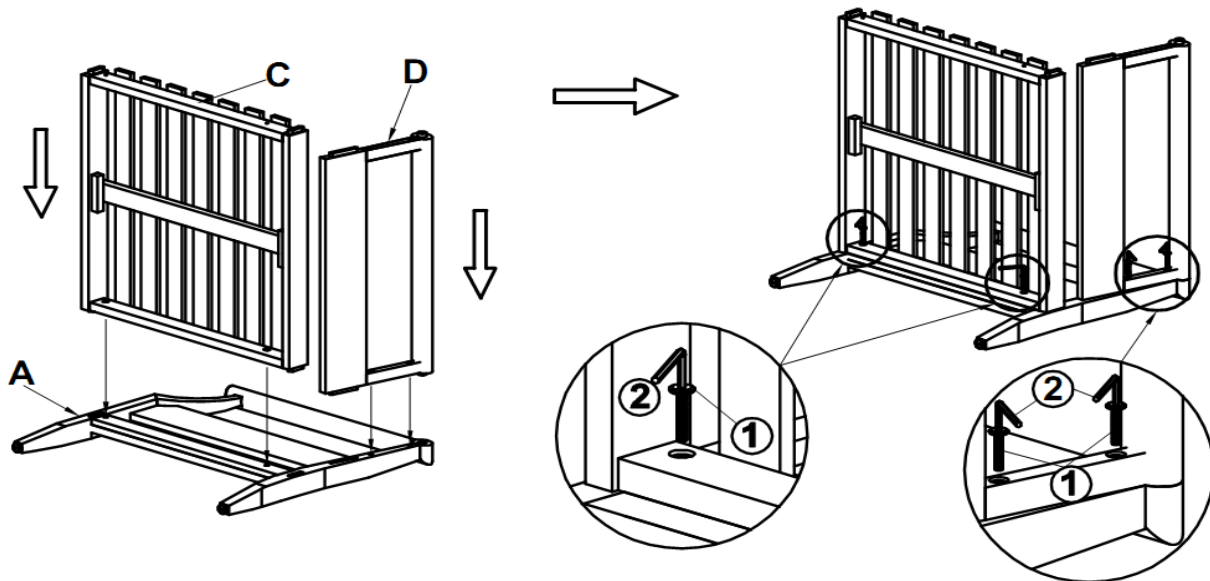

With assistance from your adult partner, position the Seat Panel(C) and the Backrest Panel(D) to the Left Leg Panel With Pre-installed Levellers(A) as shown in above picture.

Then secure the Seat Panel(C) to the Left Leg Panel With Pre-installed Levellers(A) using 2 Bolts(①) and the Allen Wrench(②).

And secure the Backrest Panel(D) to the Left Leg Panel With Pre-installed Levellers(A) using Bolt(①) and the Allen Wrench(②).

Do not fully tighten the Bolts.

Step 3

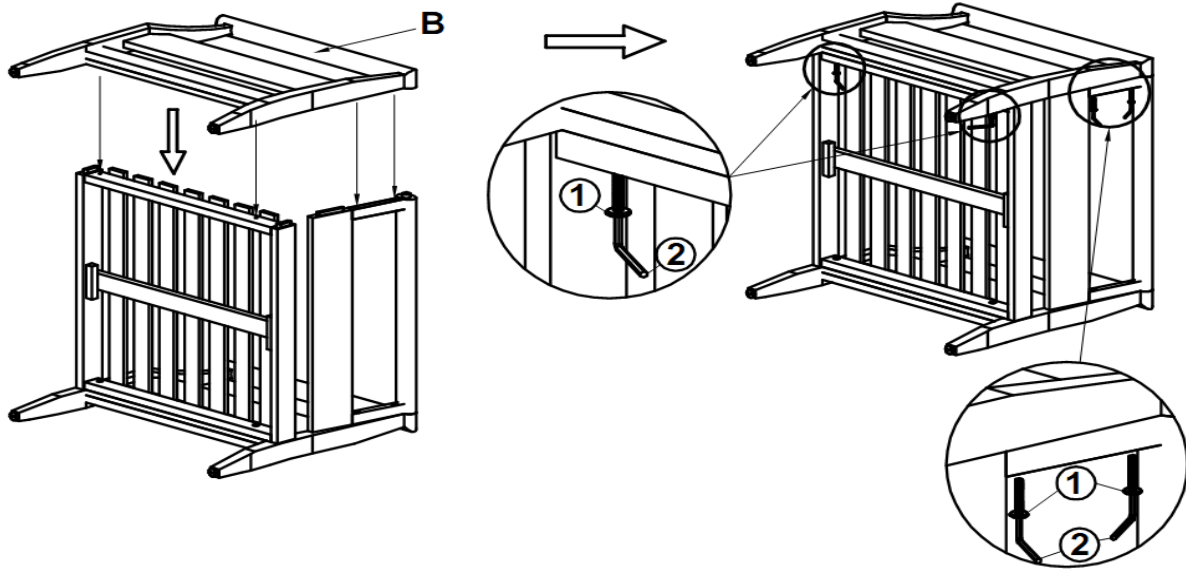

With assistance from your adult partner, position the Right Leg Panel With the Pre-installed Levellers(B) to the Seat Panel(C) and the Backrest Panel(D) as shown in the above picture.

Then repeat the same process of Step 2 to secure the Right Leg Panel With Pre-installed Levellers(B) to the Seat Panel(C) and the Backrest Panel(D).

Do not fully tighten the Bolts.

Step 4

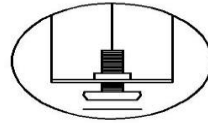
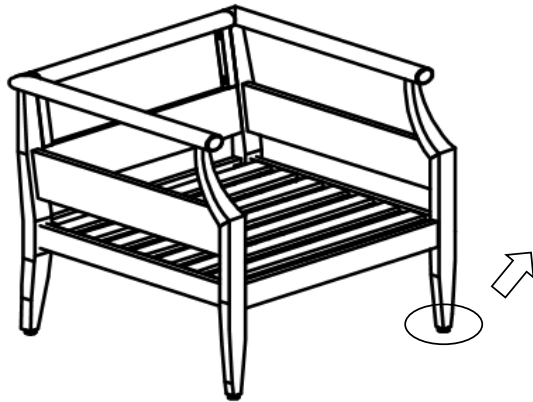

Adjust height for balance

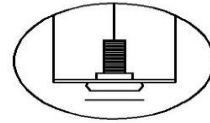

Adjust low for balance

Adjust Pre-installed Levellers

Stand the Chair up, with assistance from your adult partner.
Exert pressure floorwards, onto the Chair with both your hands.
This pressure will help the Legs and Chair reach full alignment status.
Check for wobbles on a LEVEL surface.
If no wobbles are found proceed to tighten Bolts in a sequential manner, until evenly secured.
When tightening Bolts tighten sequentially.
Do not tighten any Bolt fully and then move on towards the next one.
If there are still wobbles, loosen Bolts and execute the same above process.
Adjust the Levellers until the Chair is level with the ground.
To adjust the Levellers, get assistance from an adult partner to lift/lean and hold the Chair while you are working.

Step 5

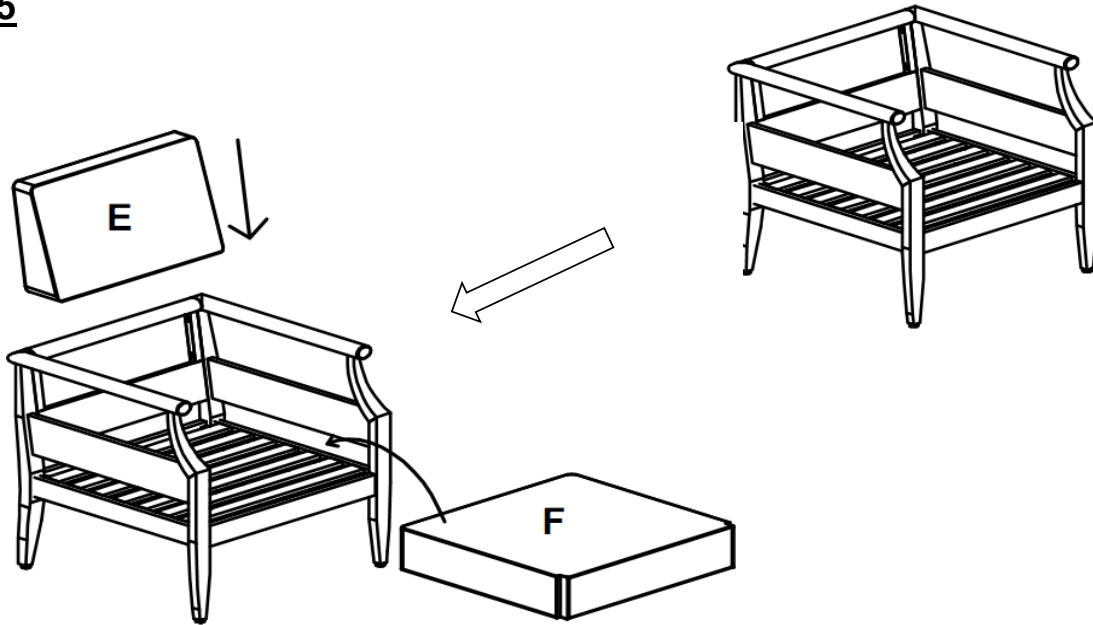

Place the Back Cushion(E) and the Seat Cushion(F) onto the Chair as shown in the above picture.

Step 6

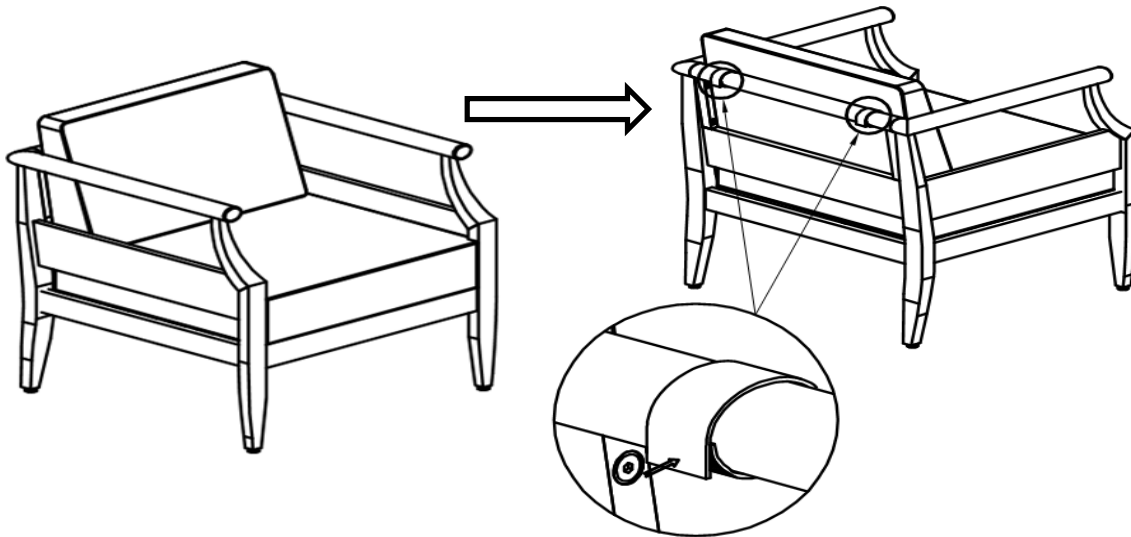









Tie the magic tape straps on the Backrest Cushion (E) and the Seat Cushion (F) to the Backrest Panel (D) and the Seat Panel (C) .

Your Chair is ready for use.

This Chair can only be used on a flat, level surface.

Care & Maintenance

- ⊗  ● Do not put hot items directly on furniture surface.
- ⊗  ● Do not clean furniture with harsh cleansers or polish.
- ✓  ● To obtain the longest lifespan of your outdoor products, minimizing exposure to direct sunlight is recommended.
- ⊗  ● Children should not climb or jump on the furniture.
- ⊗  ● Do not write on furniture without a padded barrier to protect the surface.
- ✓  ● To obtain the longest lifespan of your outdoor products, avoid extended and lengthy exposure to rain, snow, and direct sunshine. Whenever possible cover the product and /or place under patio or awnings.
- ⊗  ● Not for commercial use. For residential use only.
- ⊗  ● Stains may be removed with mild soap solution and damp cloth.
- ✓  ● Dust and pick-up spills using a clean, non-colored, lint-free cloth .