

# Coffee Table

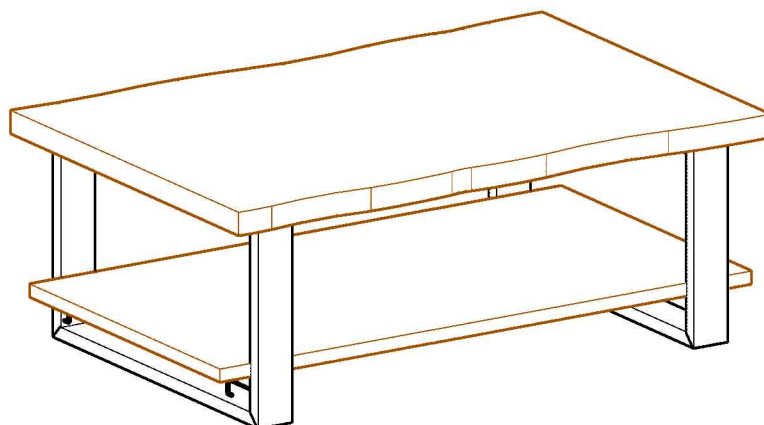







Thank you for purchasing our Coffee Table. It will be helpful to have a second person available during the assembly of this product.

---

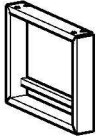
## Assembly Instructions

Lay out all parts on a "non-abrasive" surface to avoid scratching furniture.

NO.	DRAWING	DESCRIPTION	QTY.
A		TOP	1
B		SHELF	1
C		LEG	2

NO.	DRAWING	DESCRIPTION	QTY.
D		M6X35MM BOLT	8
E		M6X20MM BOLT	4
F		ALLEN KEY	1

### Step 1

Read through these instructions thoroughly before beginning assembly. We have found this to be of great value when first assembling this product.

### Step 2

Remove all parts and hardware from packing material. Wooden pieces should be placed on a non abrasive surface (like the carton or carpet) to prevent damage to the finish.

### Step 3

Lay Top (A) upside down and attach 2 Legs (C) using 8 6M x 35MM Bolts (D).  
**DO NOT TIGHTEN FIRMLY AT THIS TIME.**

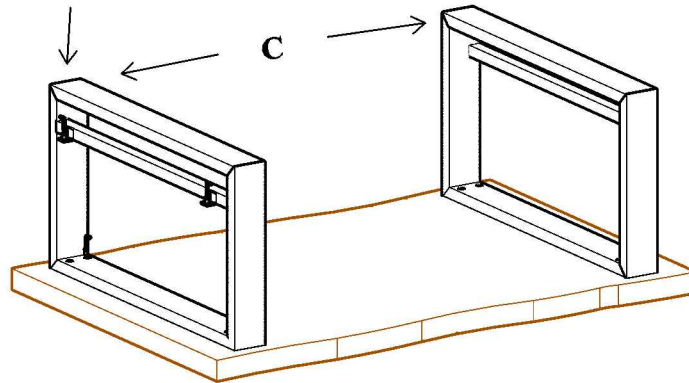

### Step 4

Lay on side and attach Shelf (B) to Legs (C) using 4 6M x 20MM Bolts (E).

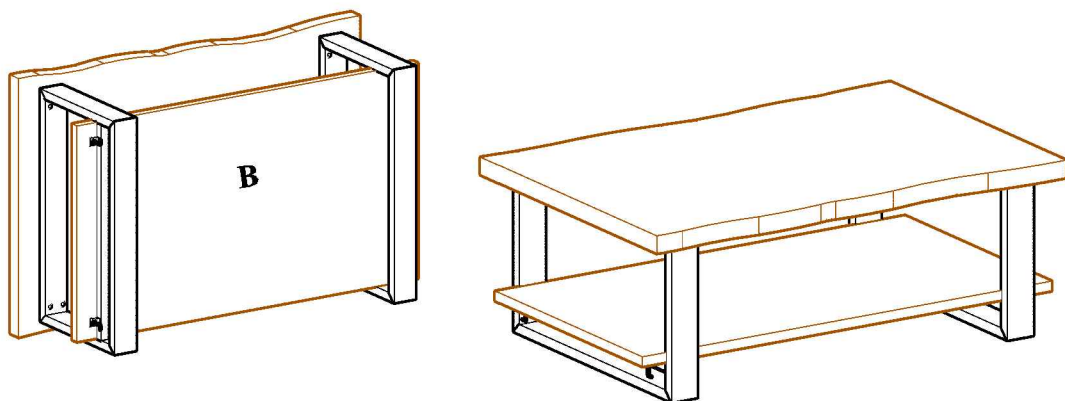

**TIGHTEN ALL BOLTS FIRMLY AT THIS TIME USING ALLEN KEY (F). SET COFFEE TABLE UPRIGHT.**

---

### CARE

Clean with mild soap and wipe dry.

---

### REPLACEMENT PARTS:

Use the order form on the web site to order your replacement parts.

Thank  
You!