

Instruction Manual

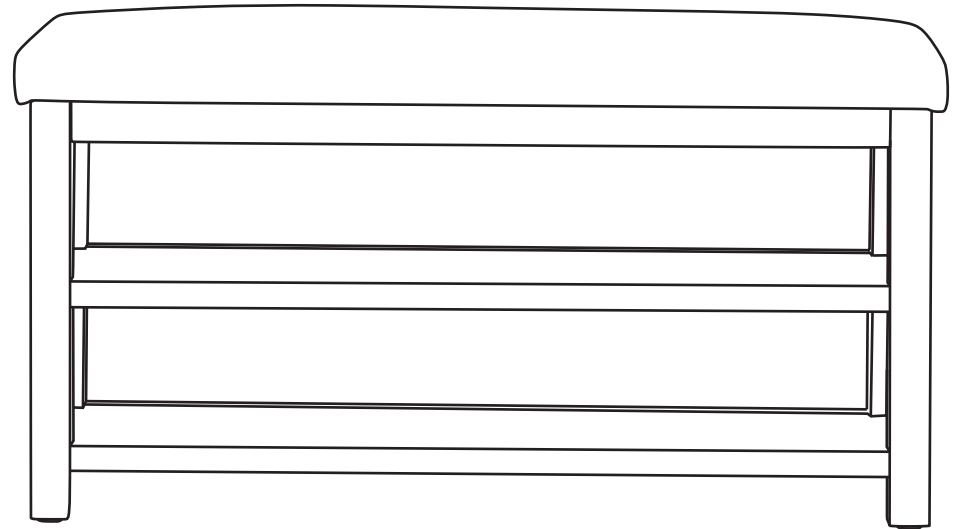



User Guide

Make life better

Warm tips: We are proud of high-quality products and satisfactory service, but the goods may encounter special circumstances during transportation, if you receive the goods with missing or damaged parts, please take photos and contact our customer service before returning the goods , we will customize a solution that satisfies you, thank you.

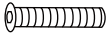

Instruction

NO	DESCRIPTION		QTY
A	Bench Seat		1
B	Board		2
C	Wooden Leg		4
D	Screw	$\Phi 5/16$ " * 2" L 	12
E	Flat Washer	$\Phi 5/16$ " * 22mm 	12
F	Lock Washer	$\Phi 5/16$ " 	12
G	Allen Wrench	$\Phi 5$ mm 	1

Note:

1. During the assembly of the two components, if there are multiple screws that need to be installed, you can first align all the screws with the hole position and manually turn a few turns to fix the position, and then tighten them all with a wrench.

2. The Flat Washer and Lock Washer must be installed to prevent the screw from loosening and damaging the connection part.

Installation Method

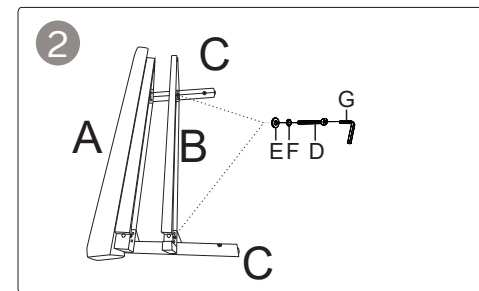
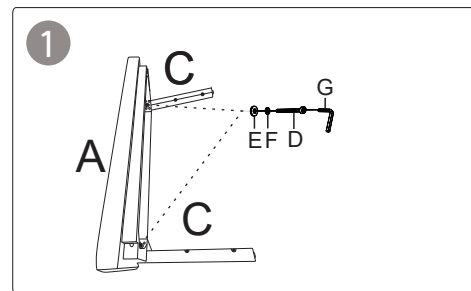

- As shown in the picture, install the two legs C on the bench seat A, turn the screws a few times until they do not fall off. Do not tighten the screws completely!
- Align board B with the hole between the two legs C, and tighten it with the screws a few times. Do not tighten it completely, just make sure the screws do not fall off.

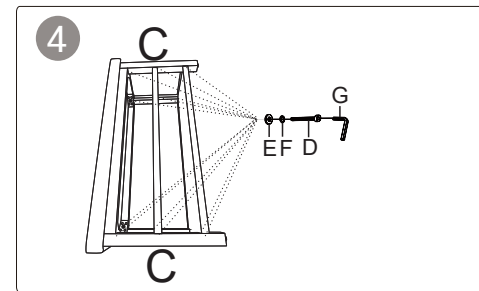
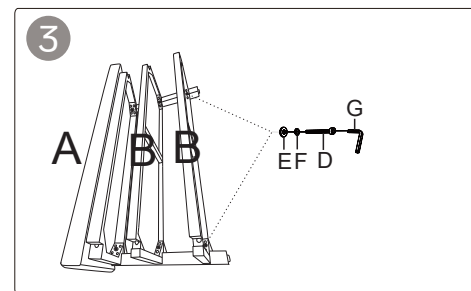

- Align the other board B with the holes at the bottom of the two legs C, and tighten the screws a few times. Do not tighten them completely, just make sure the screws do not fall off.
- Align the other two legs C with the holes of bench seat A and board B, and tighten them with screws a few times. Finally, tighten all the screws in sequence.

Tightening sequence: according to the steps shown in the figure!