

Assembly Instructions

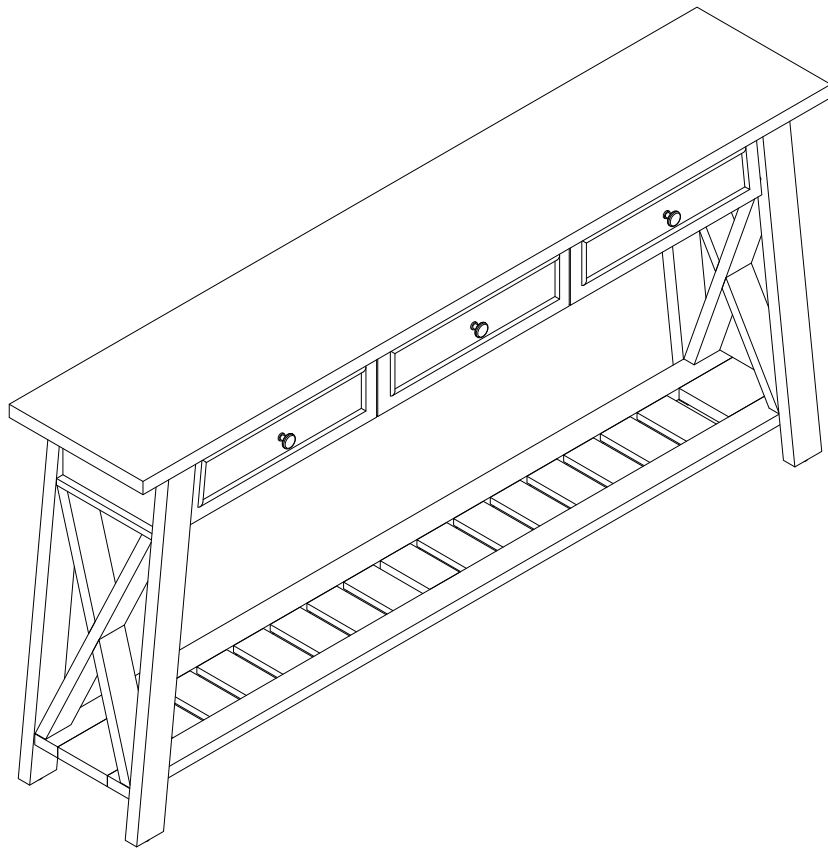

Console Table

Model No.
HOGA-RR0017

Contact Us

We're here to help you.

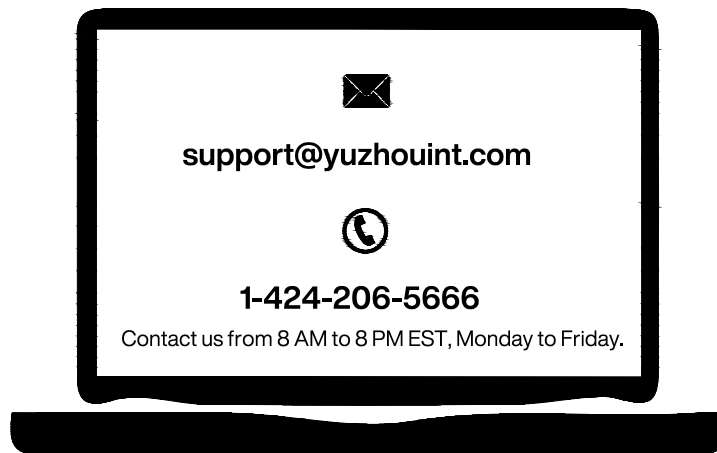

Your satisfaction is our top priority. If you encounter any issues with this product, such as missing or damaged parts, we're here to help. Please retain the original packaging and take photos of the packaging and the product, then contact us as soon as possible.

Warm Tips

1. Carefully read these instructions and keep them for future reference.
2. Check the parts list and confirm everything's there before starting assembly.
3. When assembling, put all parts on a soft, smooth surface like a carpet to avoid scratches.
4. Don't fully tighten screws until all parts are confirmed in place to avoid misalignment.

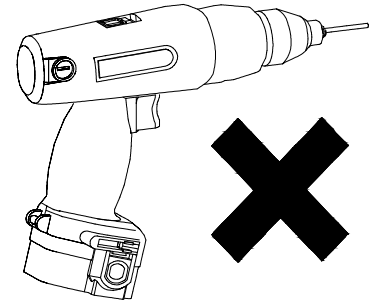
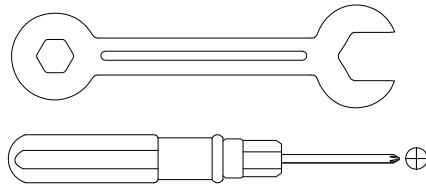
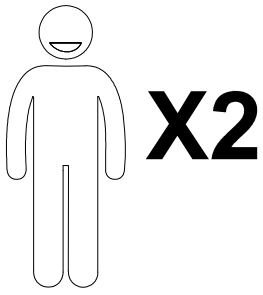

We recommend using hand tools for assembly.

If an electric screwdriver is used, reduce power and torque to avoid damage to the product.

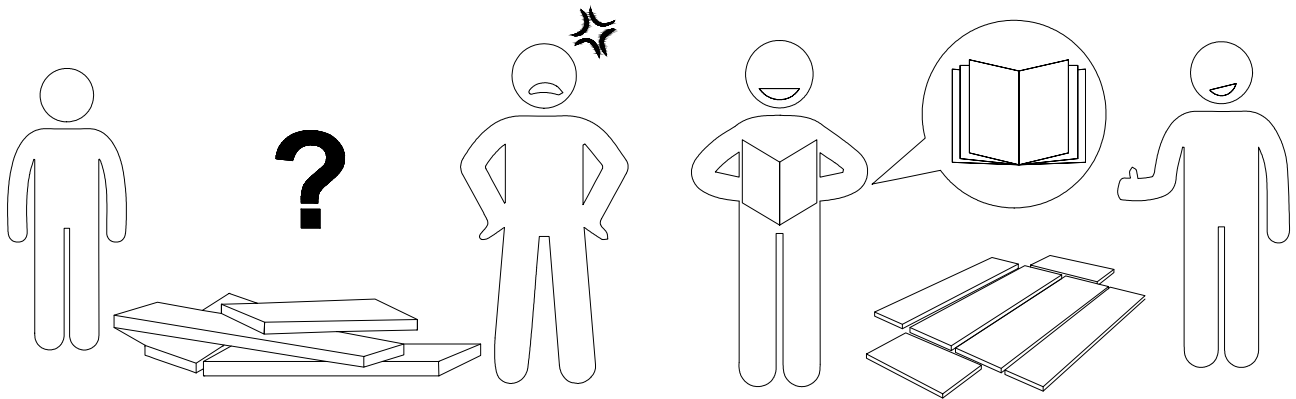

Install the Anti-Tip Straps

Using the anti-tip straps can reduce the risk of tipping over, but can not eliminate it.

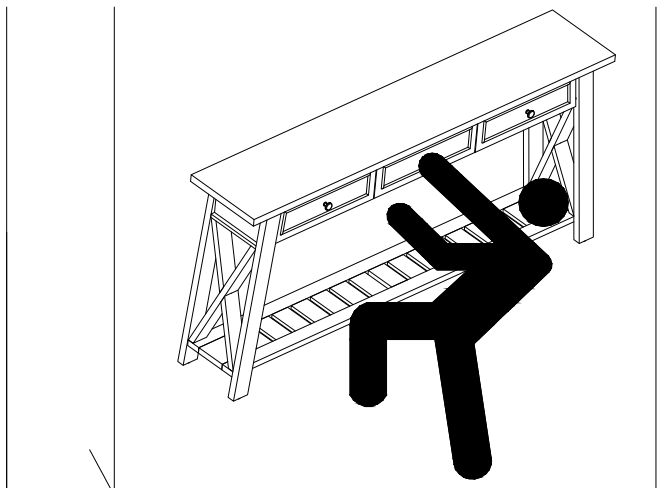
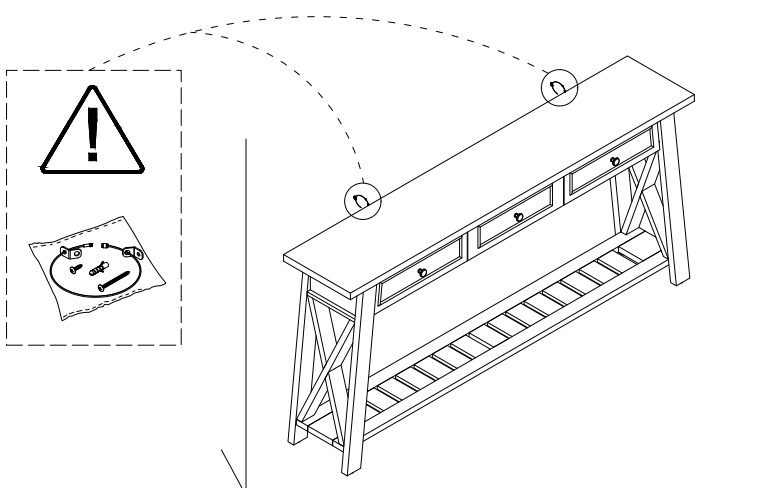

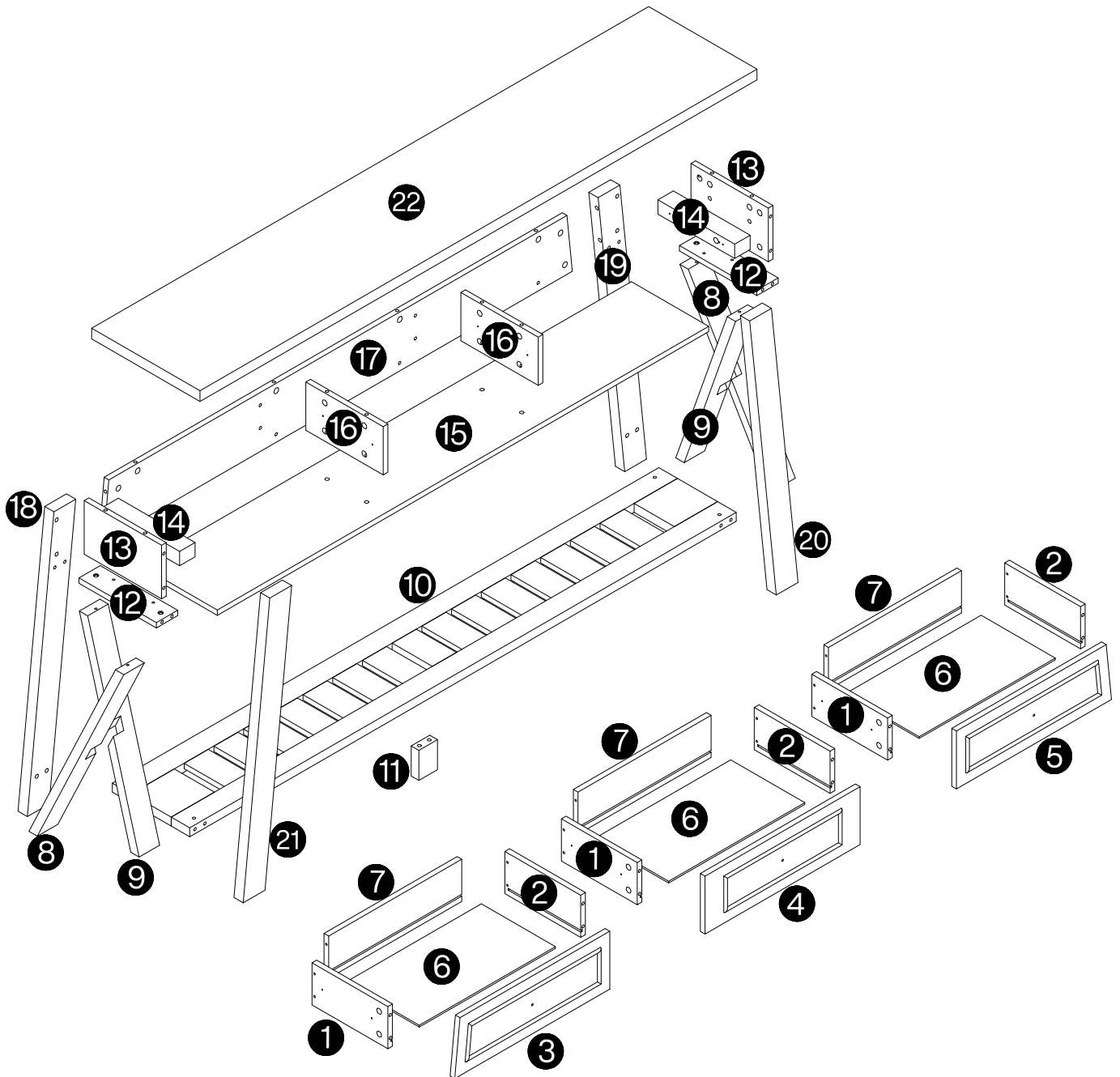

⚠ Caution



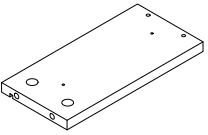
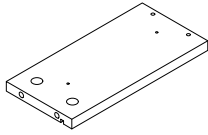
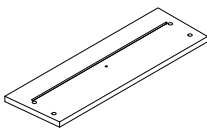
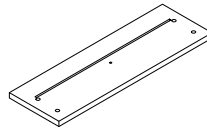
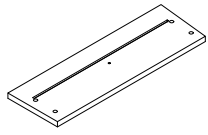
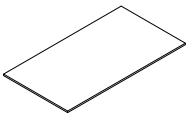
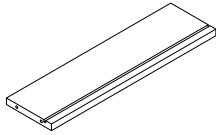
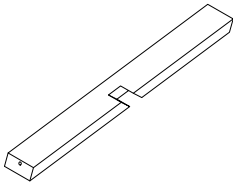
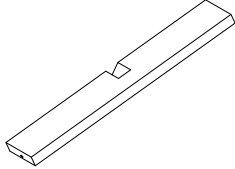
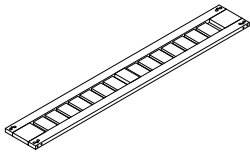
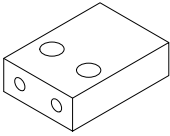
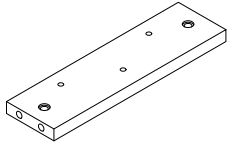
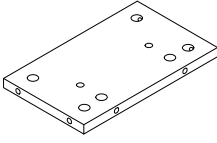
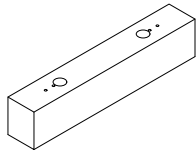
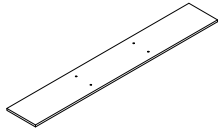
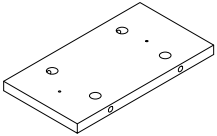
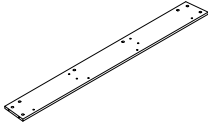
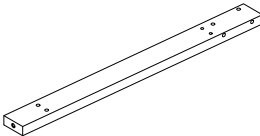
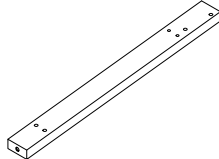
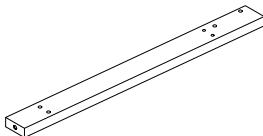
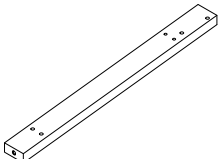
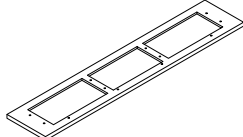

Make sure all parts are included. Most board parts are labeled or stamped on the raw edge. Contact us for a free replacement if you encounter any damaged or missing parts.

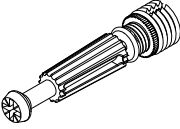
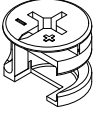
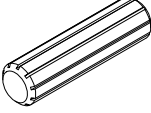
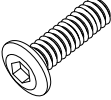
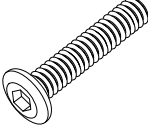
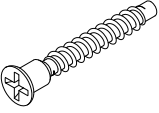

Parts List

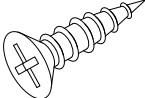
<p>1</p>  <p>3 pcs</p>	<p>2</p>  <p>3 pcs</p>	<p>3</p>  <p>1 pc</p>	<p>4</p>  <p>1 pc</p>	<p>5</p>  <p>1 pc</p>
<p>6</p>  <p>3 pcs</p>	<p>7</p>  <p>3 pcs</p>	<p>8</p>  <p>2 pcs</p>	<p>9</p>  <p>2 pcs</p>	<p>10</p>  <p>1 pc</p>
<p>11</p>  <p>1 pc</p>	<p>12</p>  <p>2 pcs</p>	<p>13</p>  <p>2 pcs</p>	<p>14</p>  <p>2 pcs</p>	<p>15</p>  <p>1 pc</p>
<p>16</p>  <p>2 pcs</p>	<p>17</p>  <p>1 pc</p>	<p>18</p>  <p>1 pc</p>	<p>19</p>  <p>1 pc</p>	<p>20</p>  <p>1 pc</p>
<p>21</p>  <p>1 pc</p>	<p>22</p>  <p>1 pc</p>			

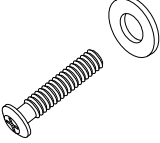
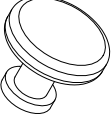
Hardware List

A	B	C	D	E	F
					
M6x35mm	Ø15x12mm	Ø8x30mm	M6x25mm	M6x45mm	Ø7x38mm
50 pcs	50 pcs	8 pcs	4 pcs	4 pcs	18 pcs

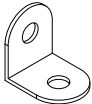
G	H	I	J	K	L
					
Ø3.5x35mm	Ø3.5x14mm	250mm	Ø4x20mm		M6x14mm
12 pcs	32 pcs	3 sets	3 pcs	3 pcs	5 pcs

M	N				
					
		M4			
2 pcs	4 pcs	1 pc	1 pc		

Installation of Cams and Pins

Step 1-2: Align the plastic part with the mounting hole and press it in. If you can't press it in, loosen the screw counter clockwise or completely remove the screw from the plastic part and try again.
Step 3-4: After pressing the plastic part into place, use a screwdriver to tighten the screw clockwise.

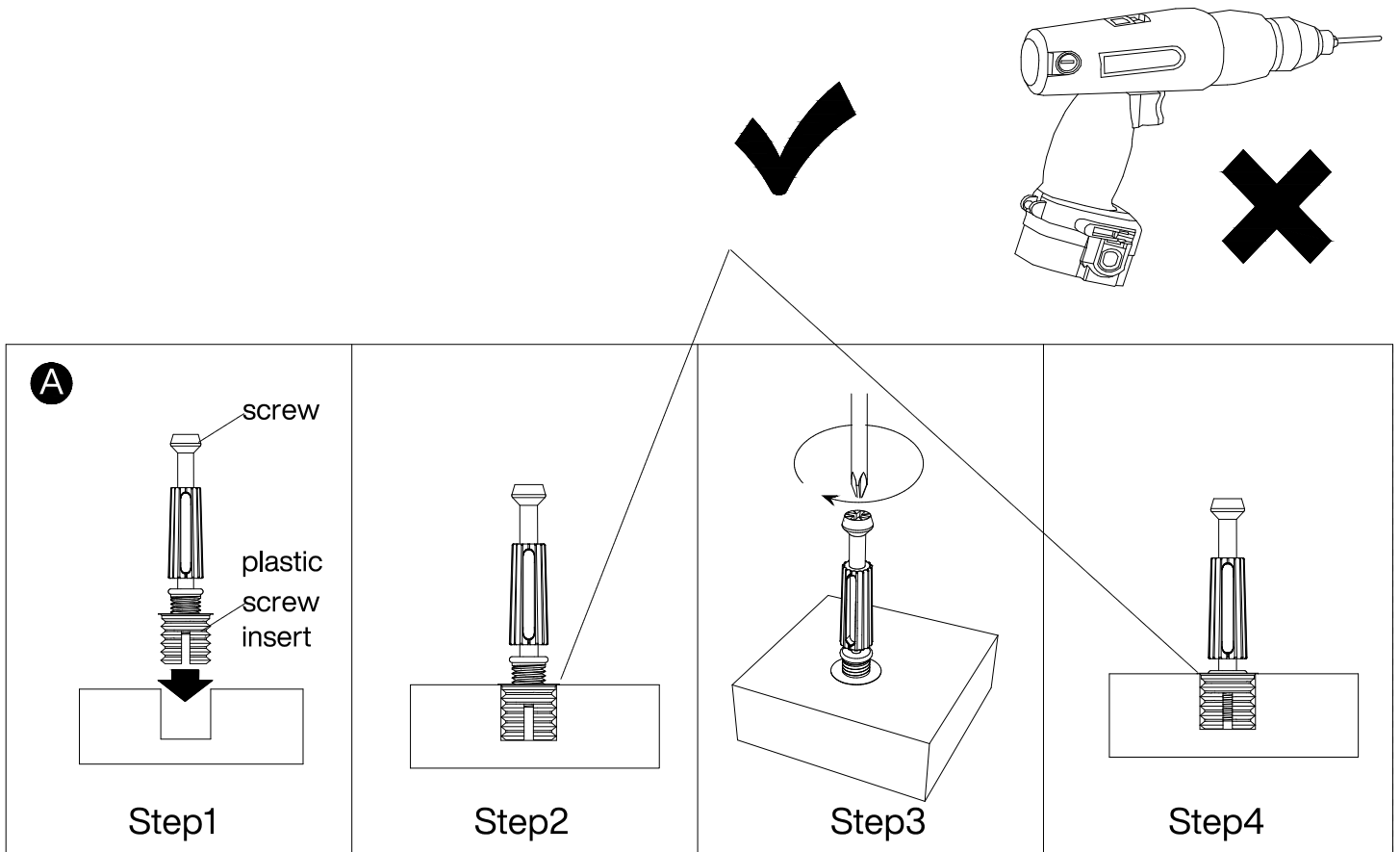

Screw the pin into the hole. Set the cams correctly by aligning the head of the cams with the lock pins. Lock the cam by turning the cam head with a screwdriver until it is tightened. Please do not use an electric screwdriver to assemble the unit.

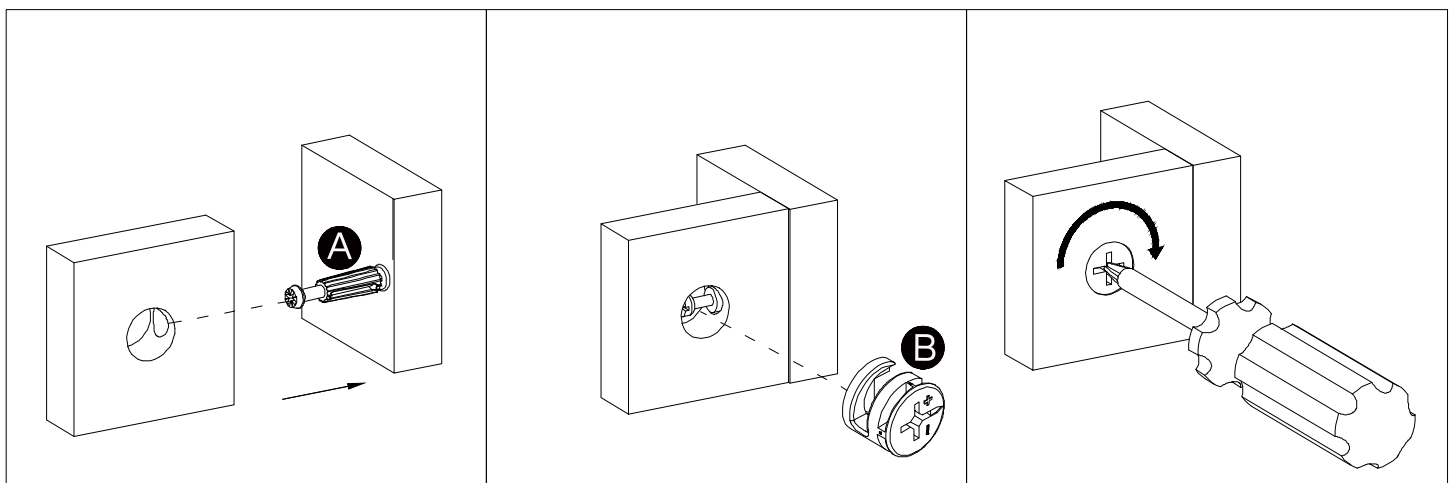

Please split component "I" into "I-1" and "I-2" before assembling the slide rail component, and then proceed to the next step of assembly

Step 1

Pull apart component "I" to each side, and then gently push up the lever of component "I-2"

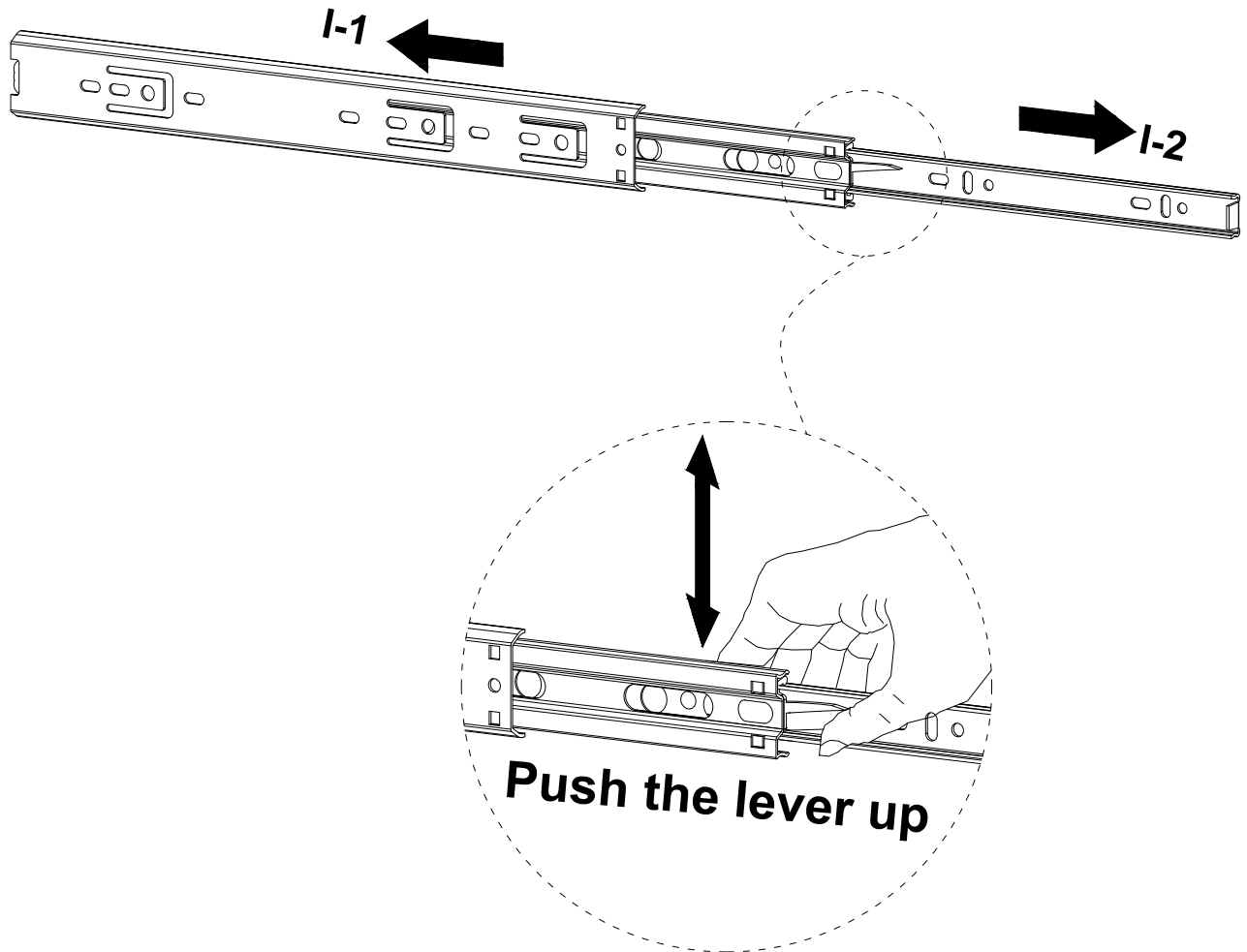

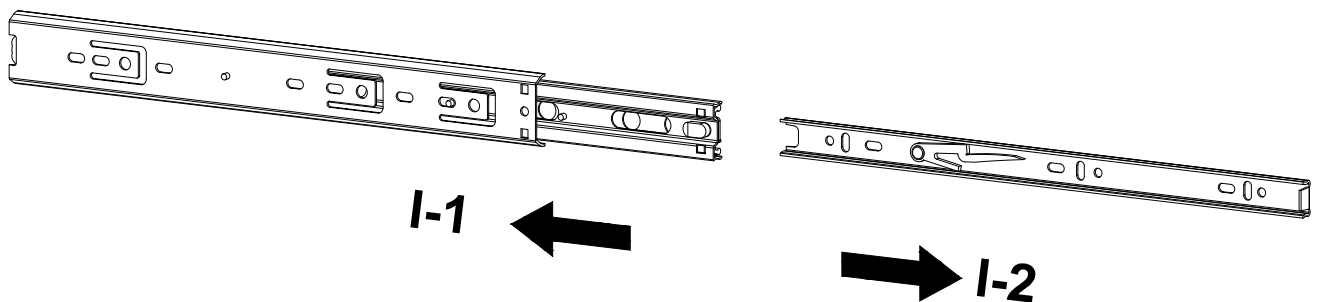

Step 2

Split component "I-1" and "I-2"

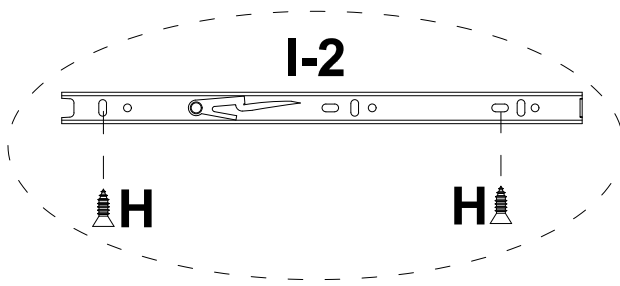

1



H	I-2
	
Ø3.5x14mm	
12 pcs	6 pcs

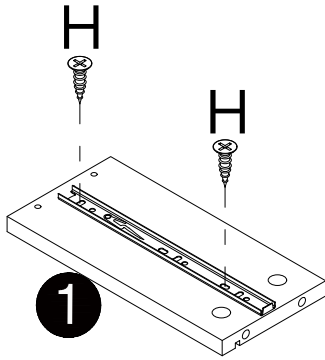

x3

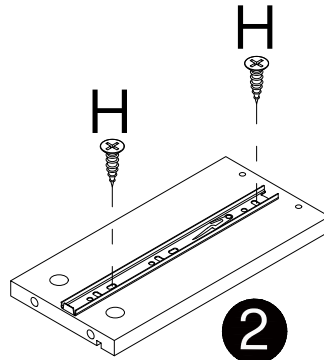

x3

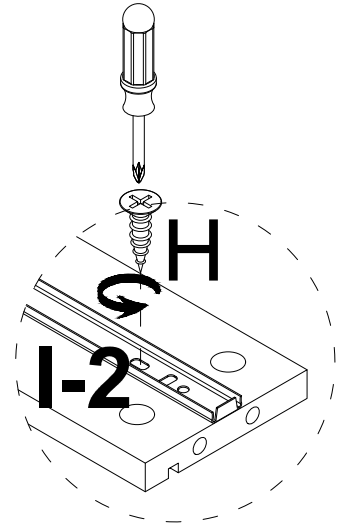

2

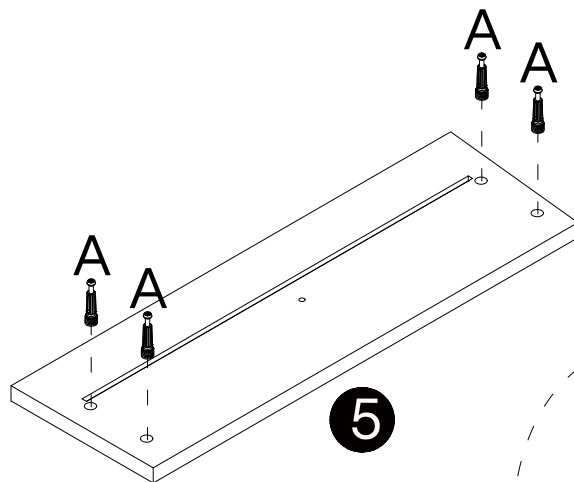
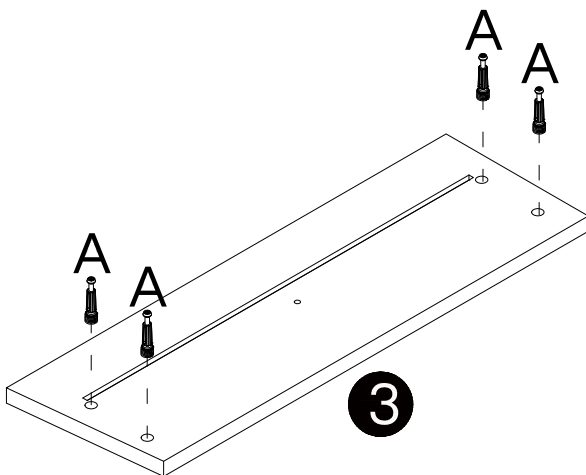

A

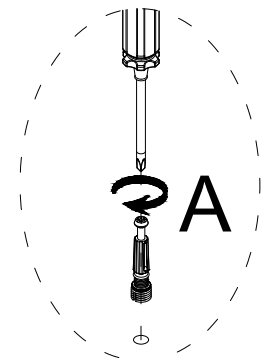
M6x35mm
8 pcs

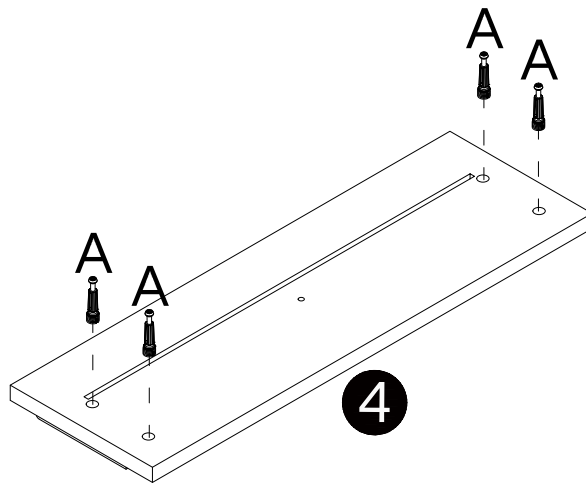

3

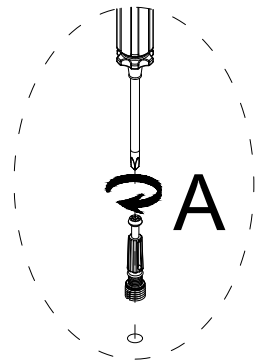

A

M6x35mm
4 pcs

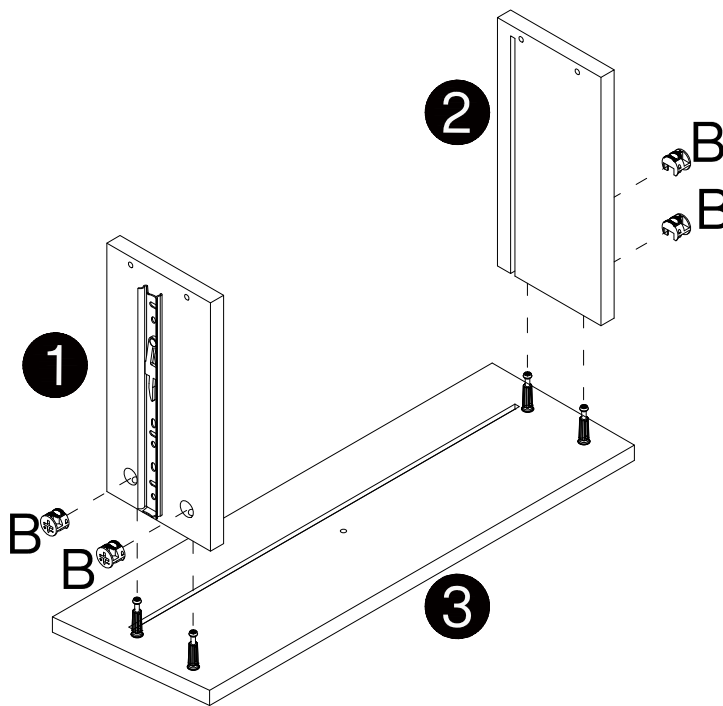

4

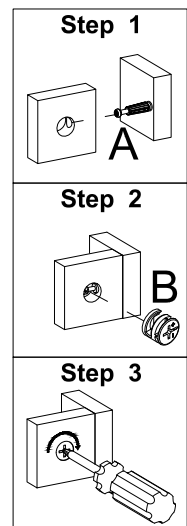

B

Ø15x12mm
4 pcs

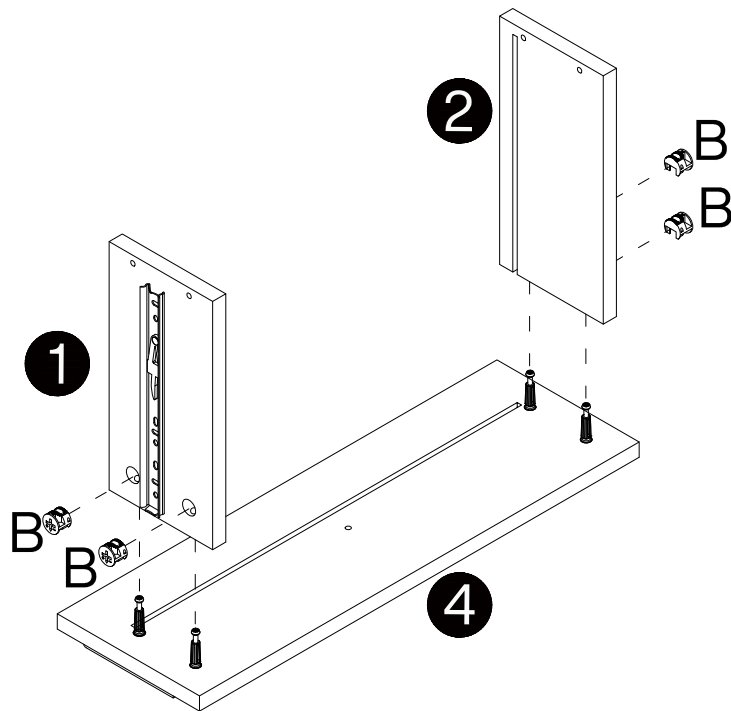

5



B

Ø15x12mm
4 pcs

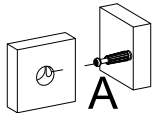
Step 1

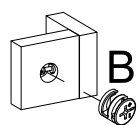

Step 2



Step 3

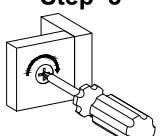

6

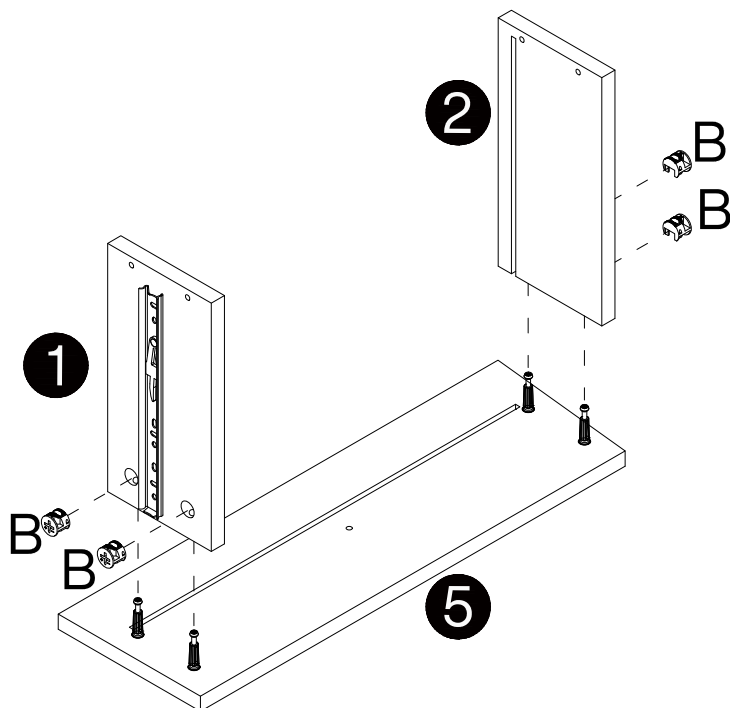

B

Ø15x12mm
4 pcs

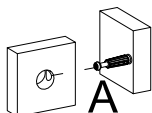
Step 1

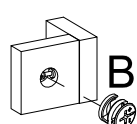

Step 2



Step 3

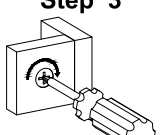

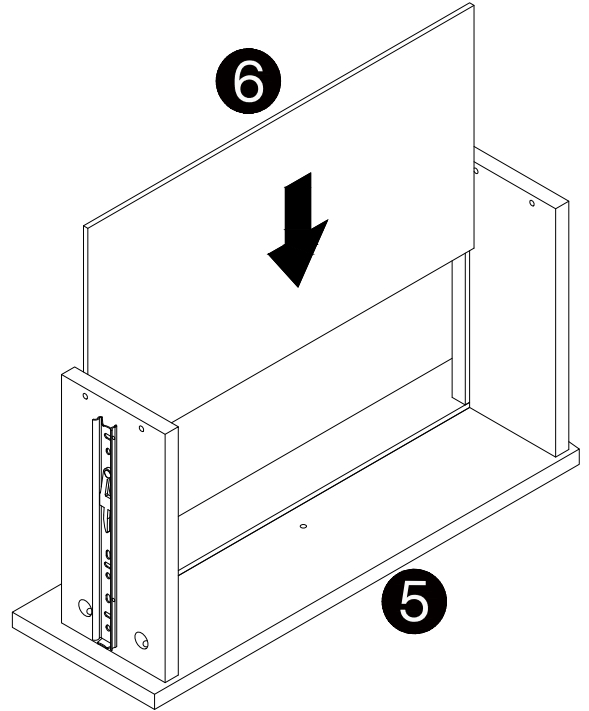
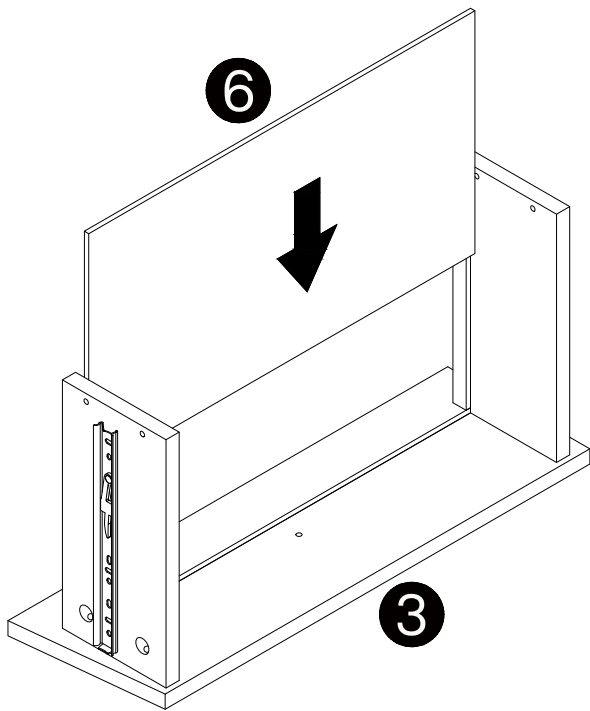

7

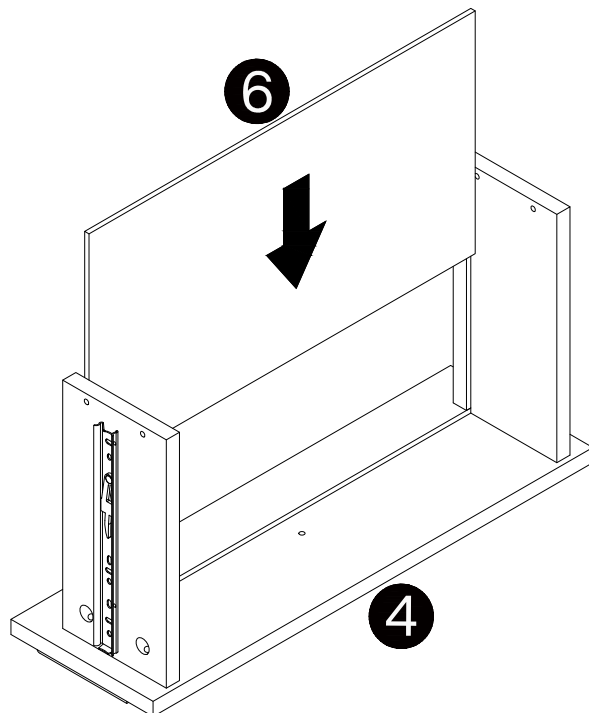

8



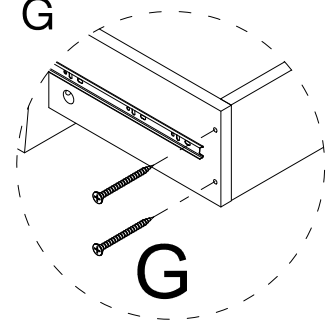
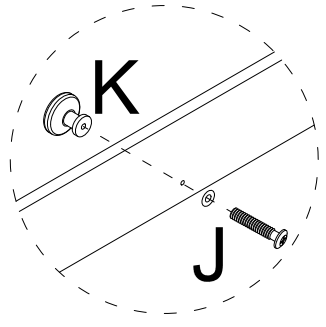
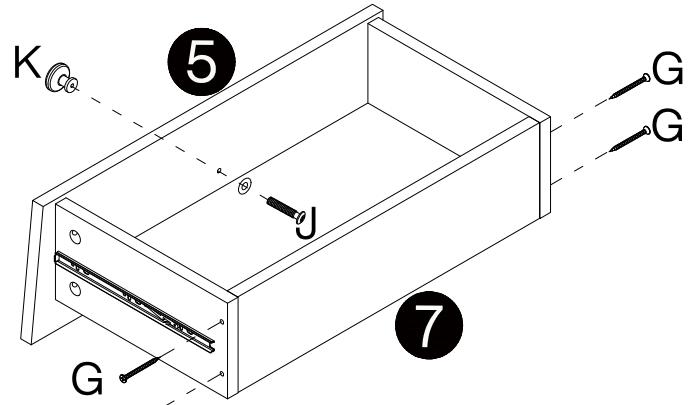
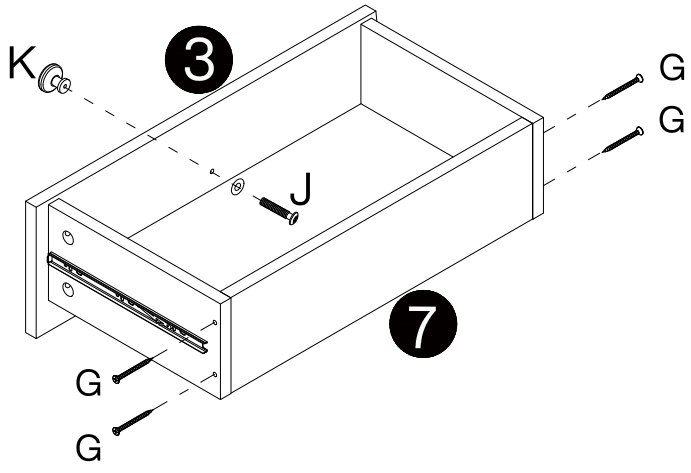

9

K	J	G
		
2 pcs	M4x20mm 2 pcs	Ø3.5x35mm 8 pcs



10

K	J	G
		
1 pc	M4x20mm 1 pc	Ø3.5x35mm 4 pcs

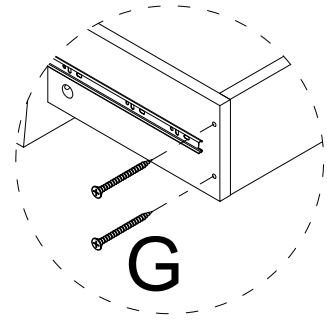
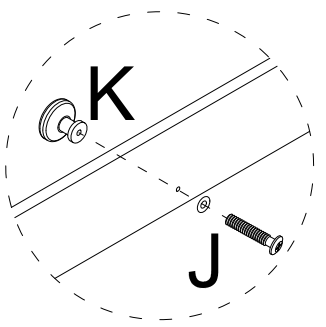
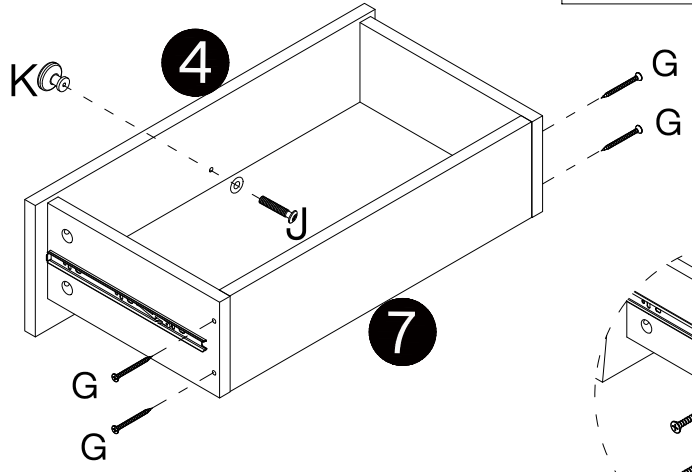

11

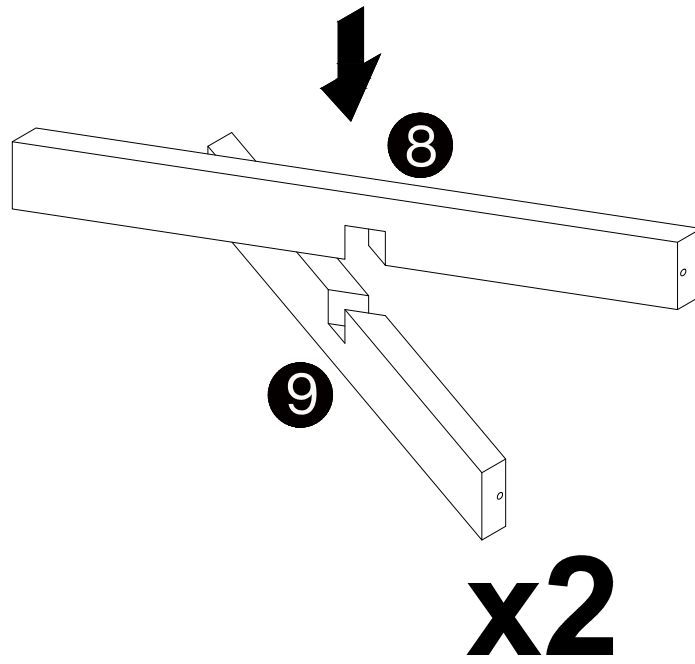

12

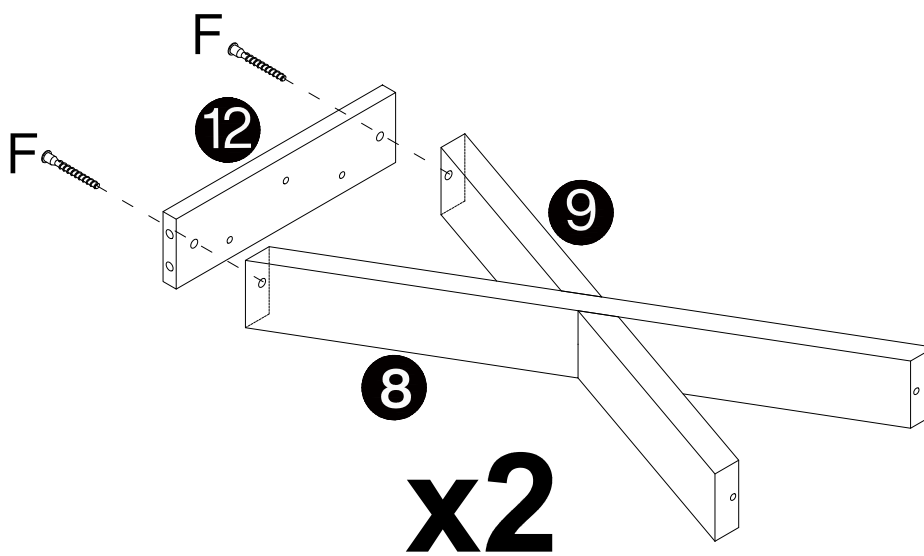

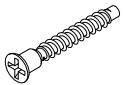
F

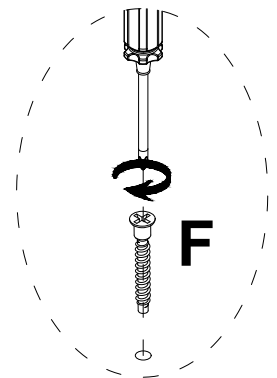
Ø7x38mm
4 pcs

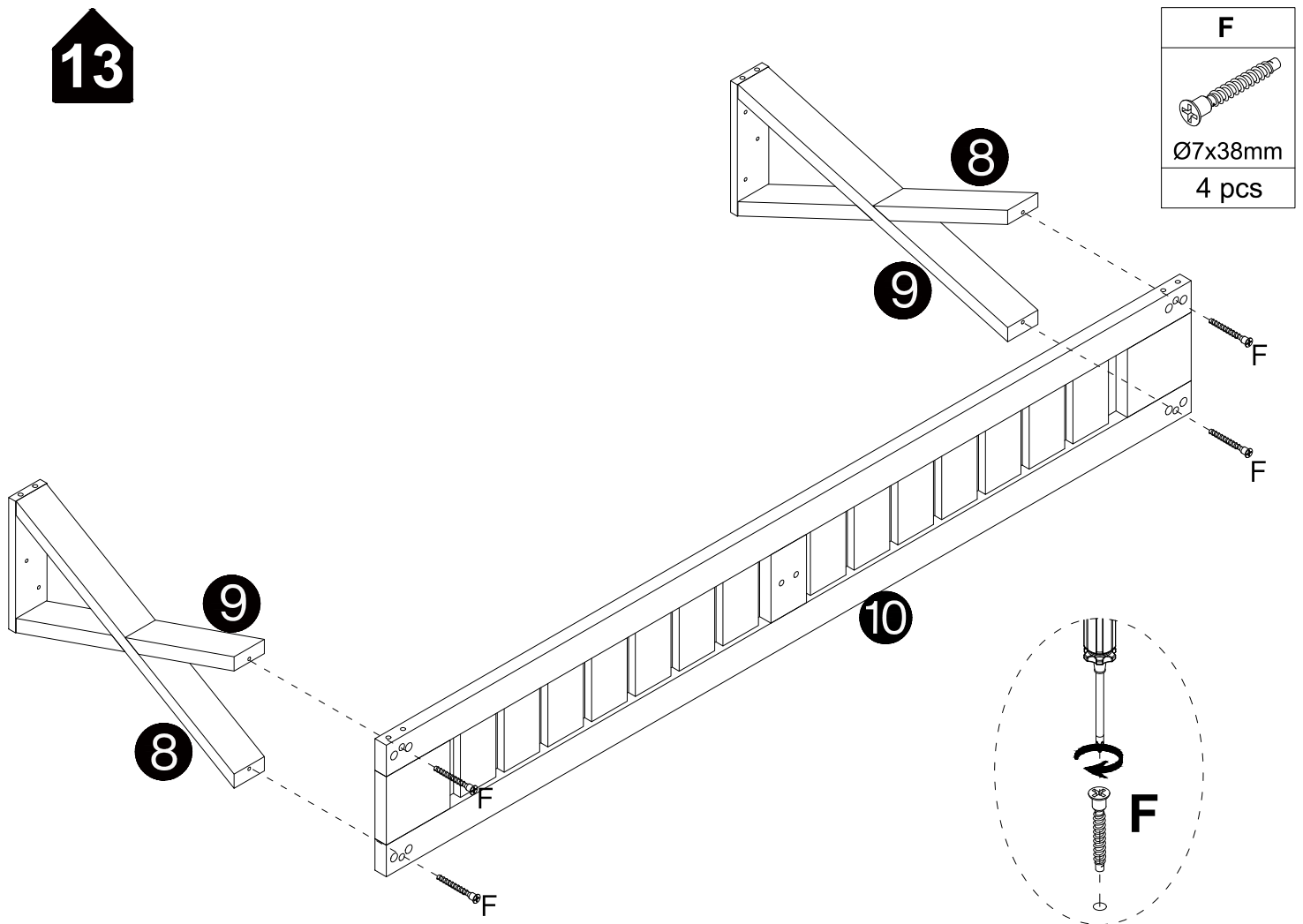

13

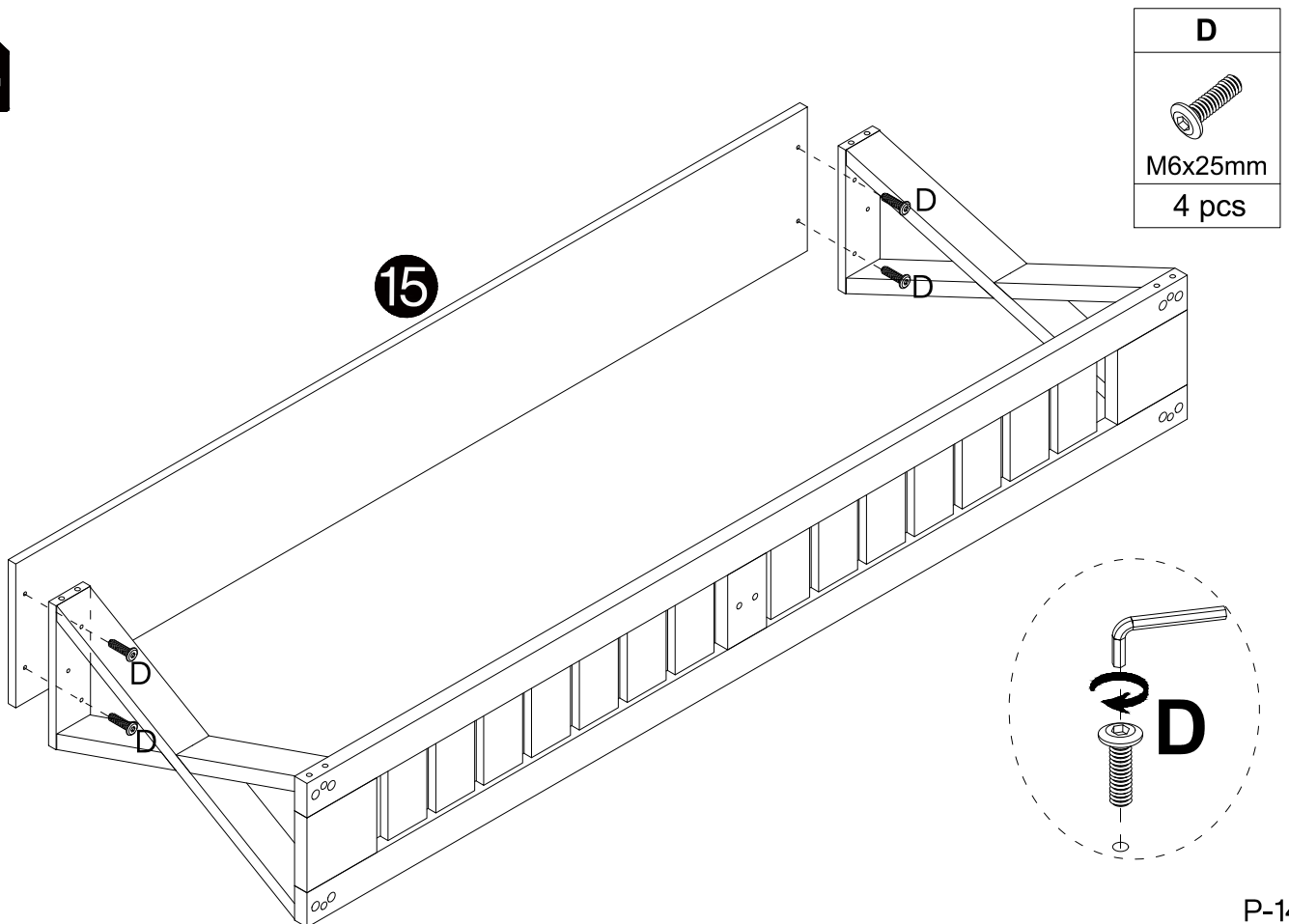

14



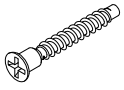

15

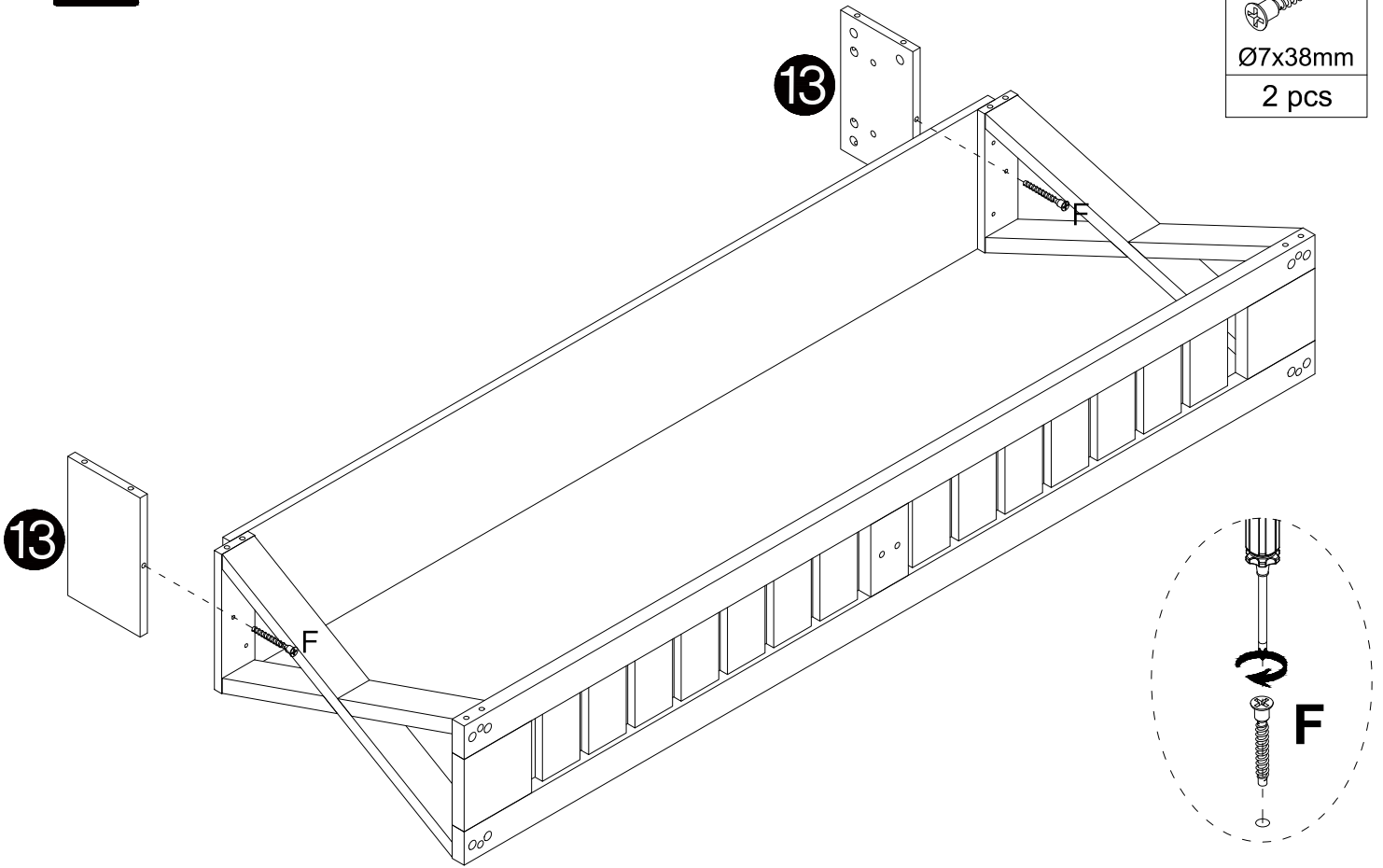
F

Ø7x38mm
2 pcs

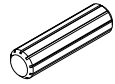

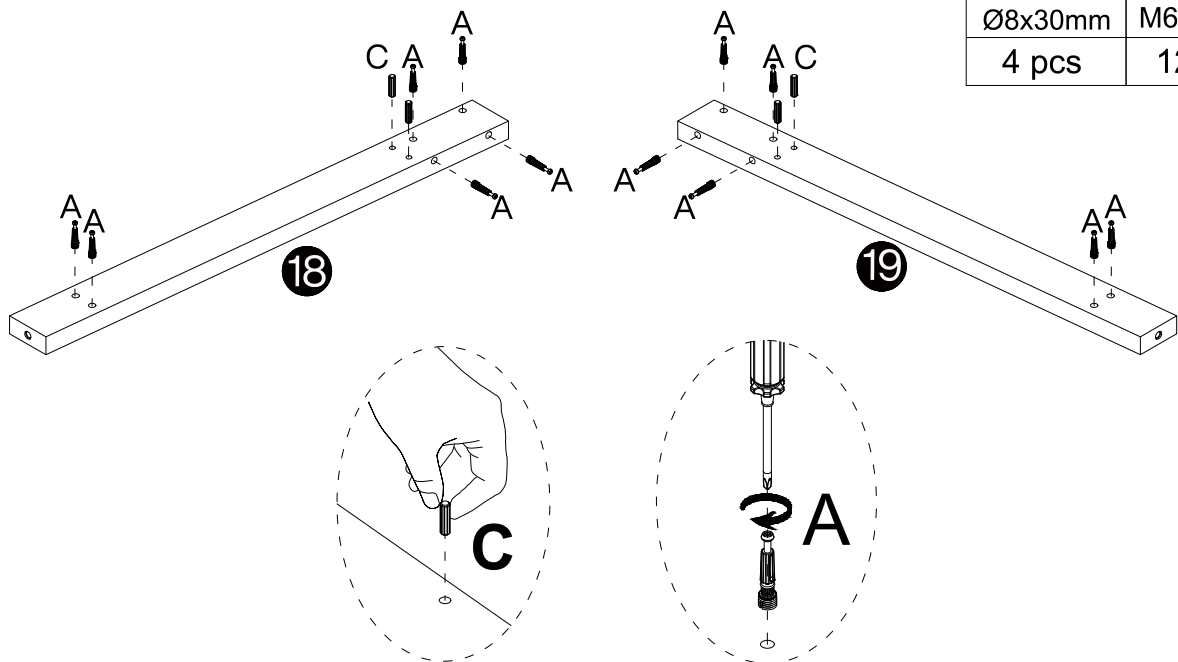

16

C	A
	
Ø8x30mm	M6x35mm
4 pcs	12 pcs

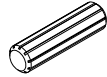

17

C	A
 Ø8x30mm	 M6x35mm
4 pcs	8 pcs

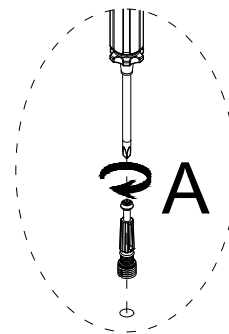
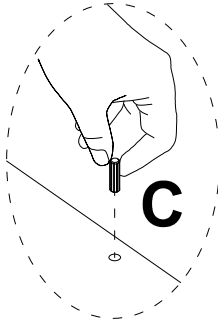
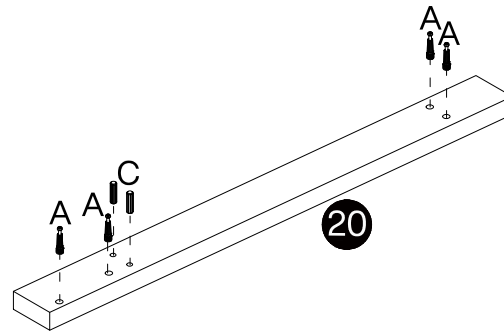
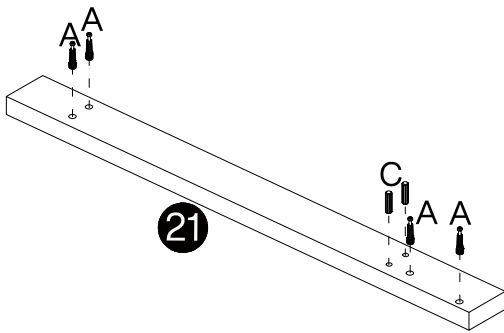

18

B
 Ø15x12mm
4 pcs

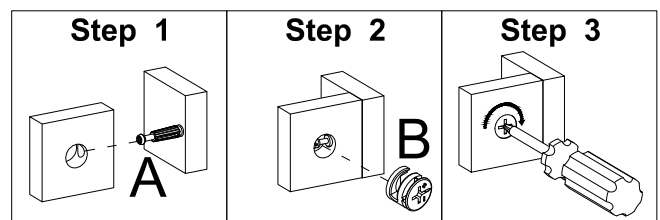
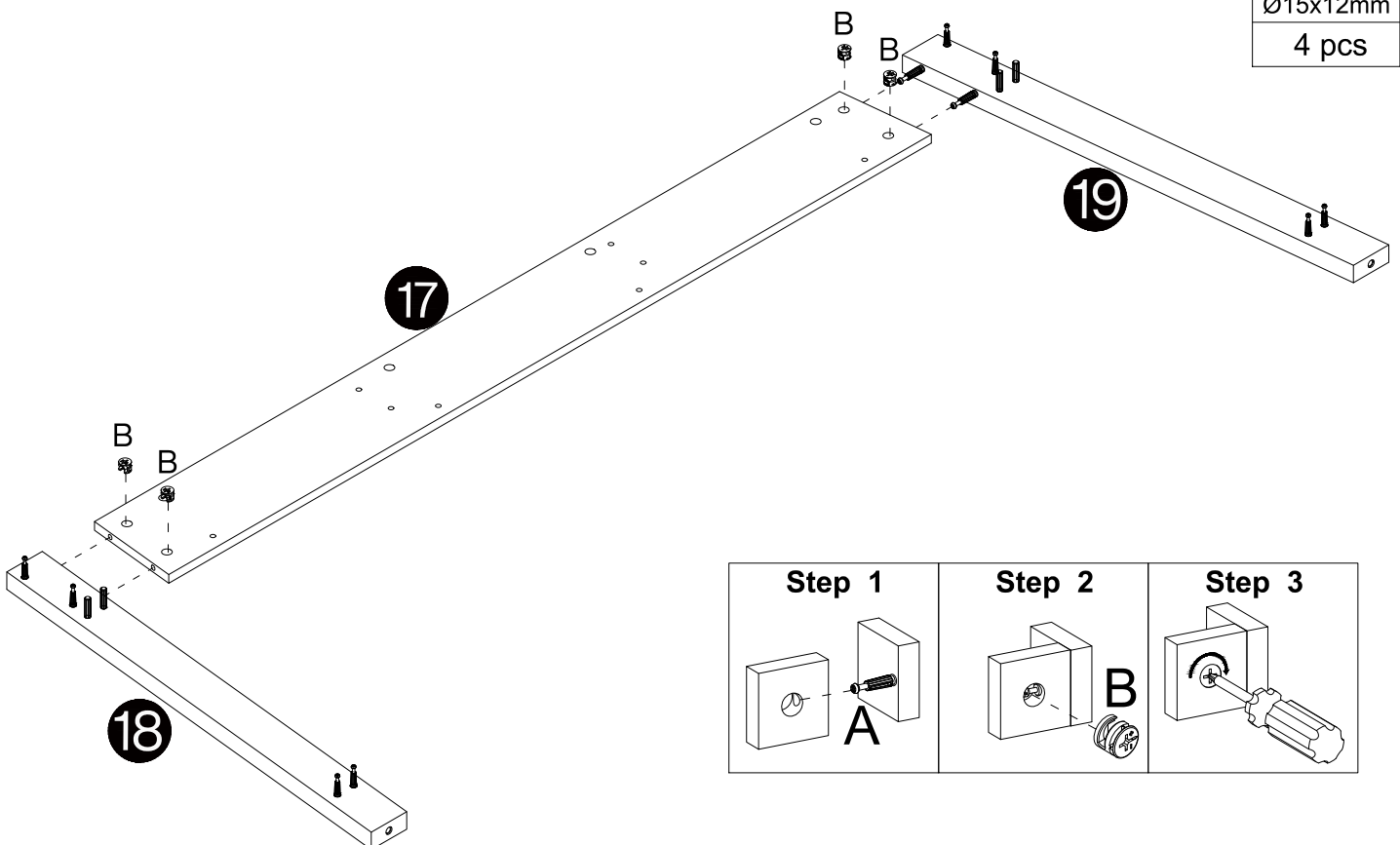

19

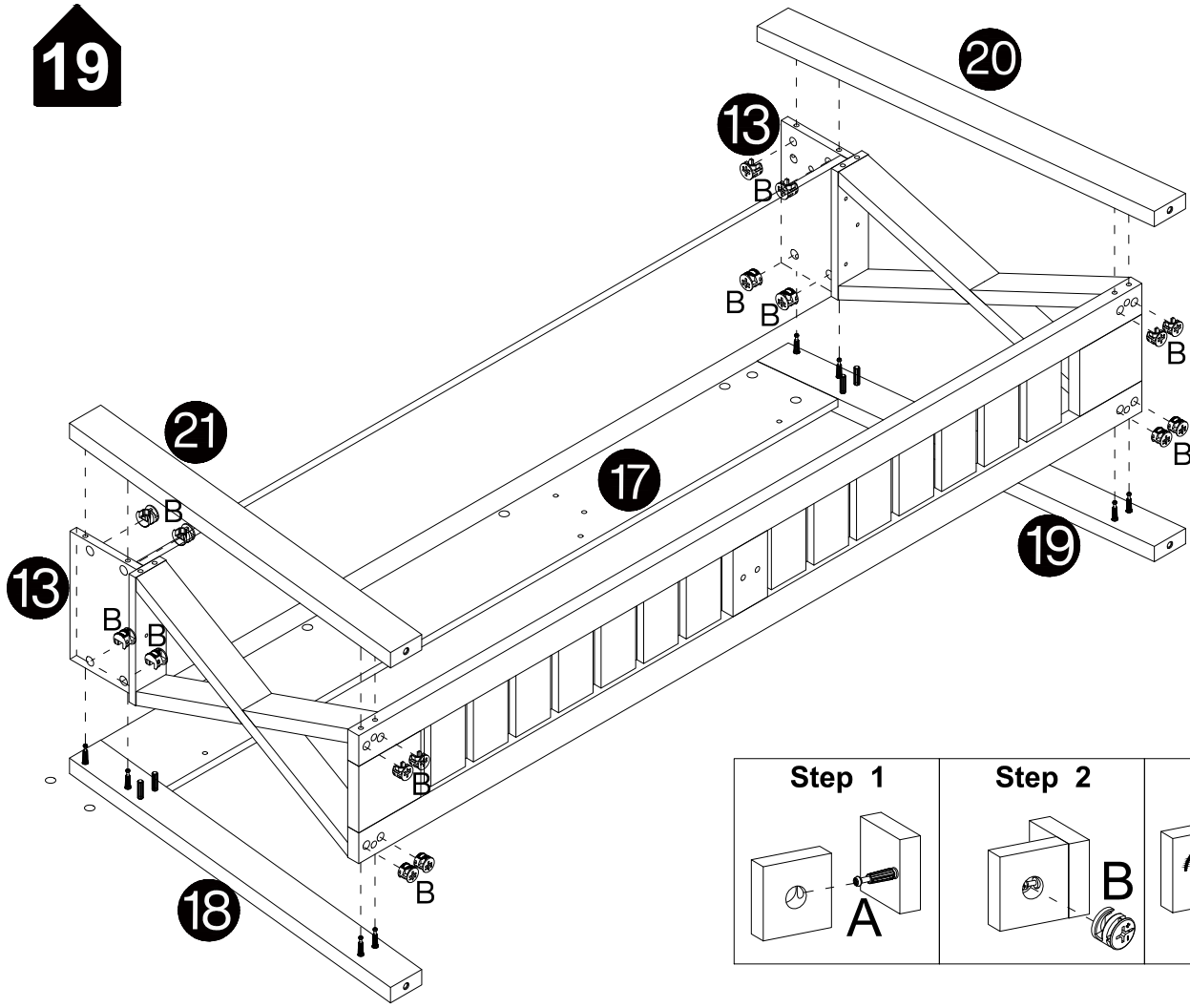

B



Ø15x12mm
16 pcs

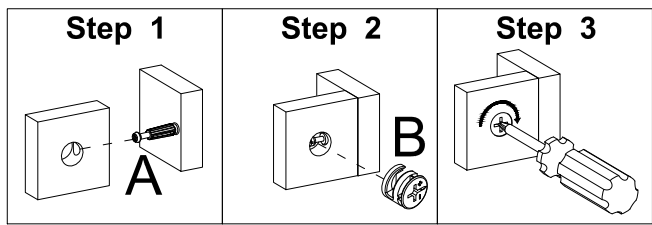

20

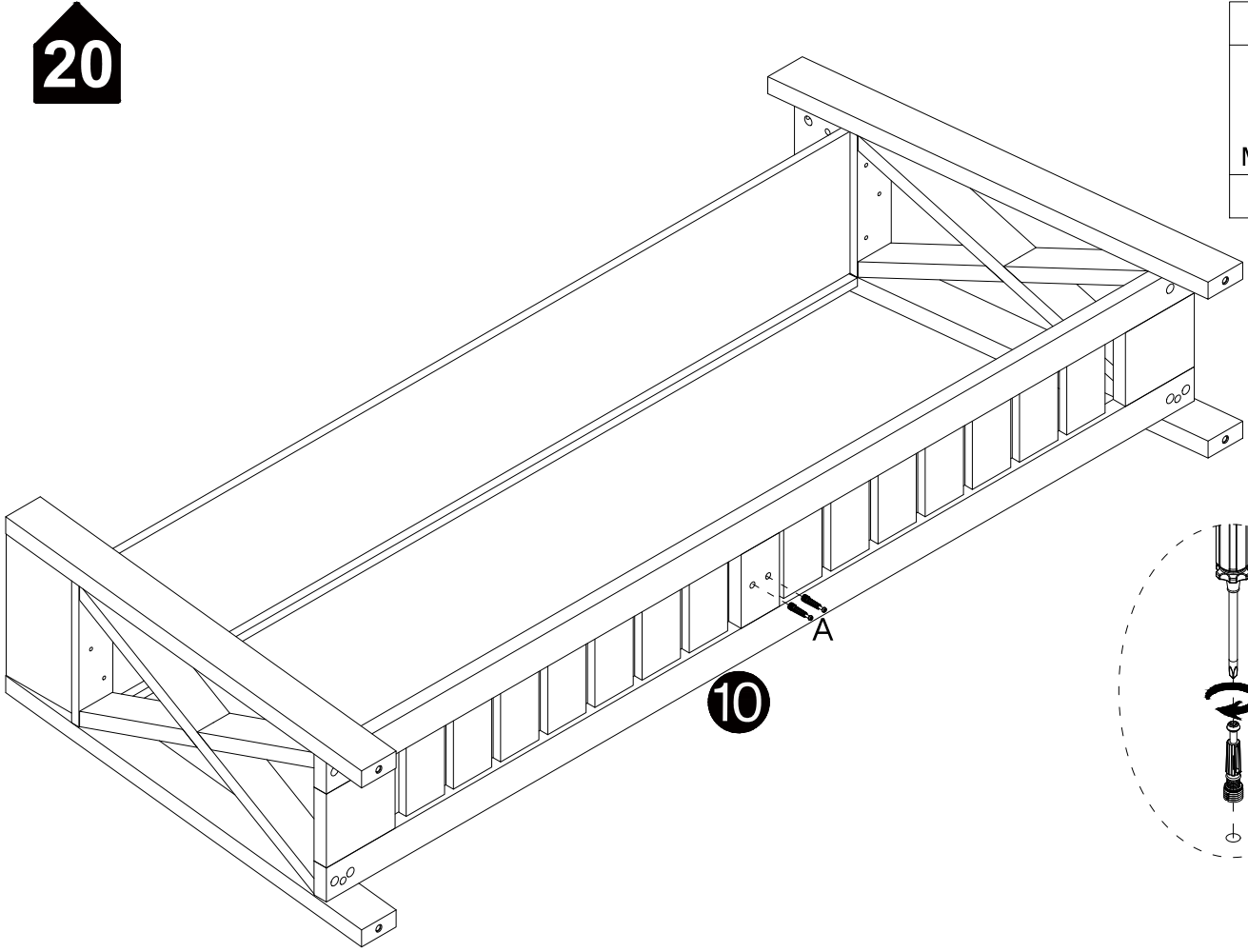

A



M6x35mm
2 pcs

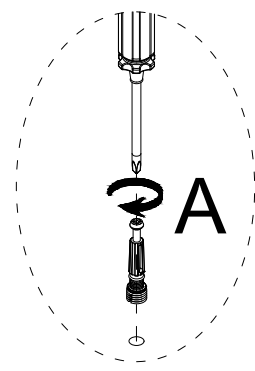

21

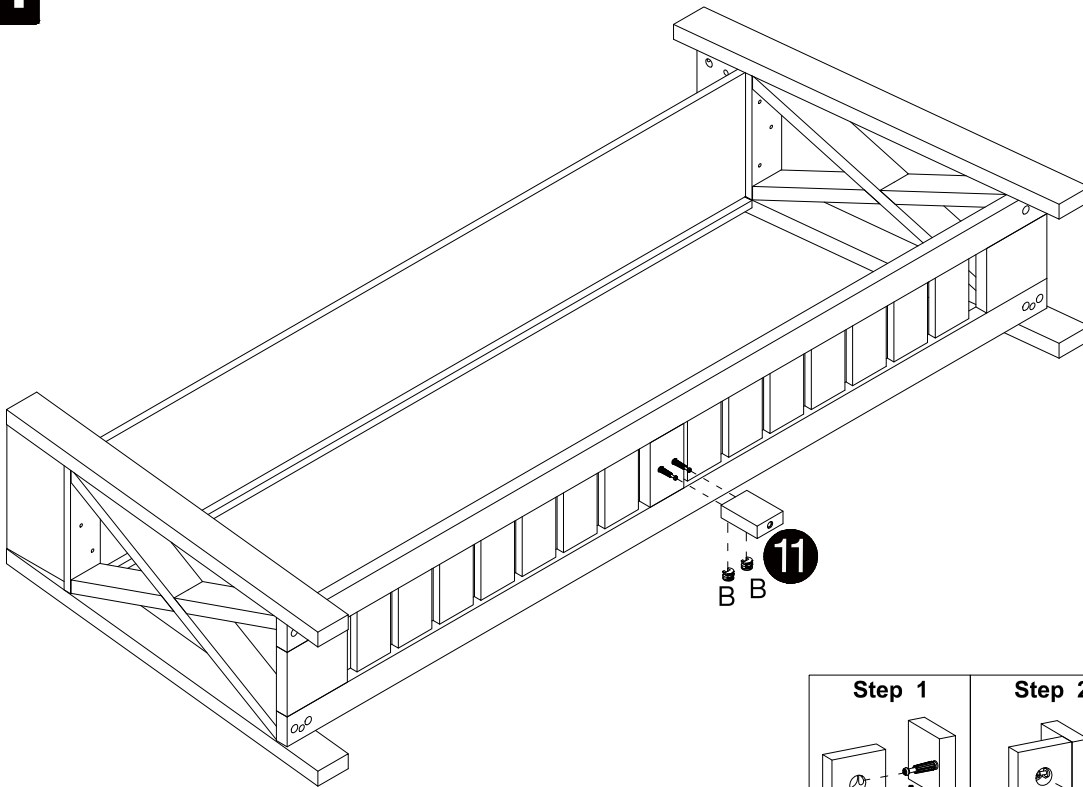

B

Ø15x12mm
2 pcs

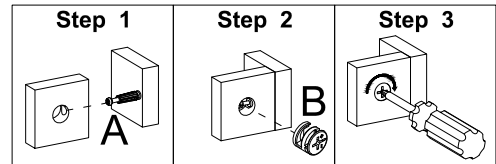

11
B B



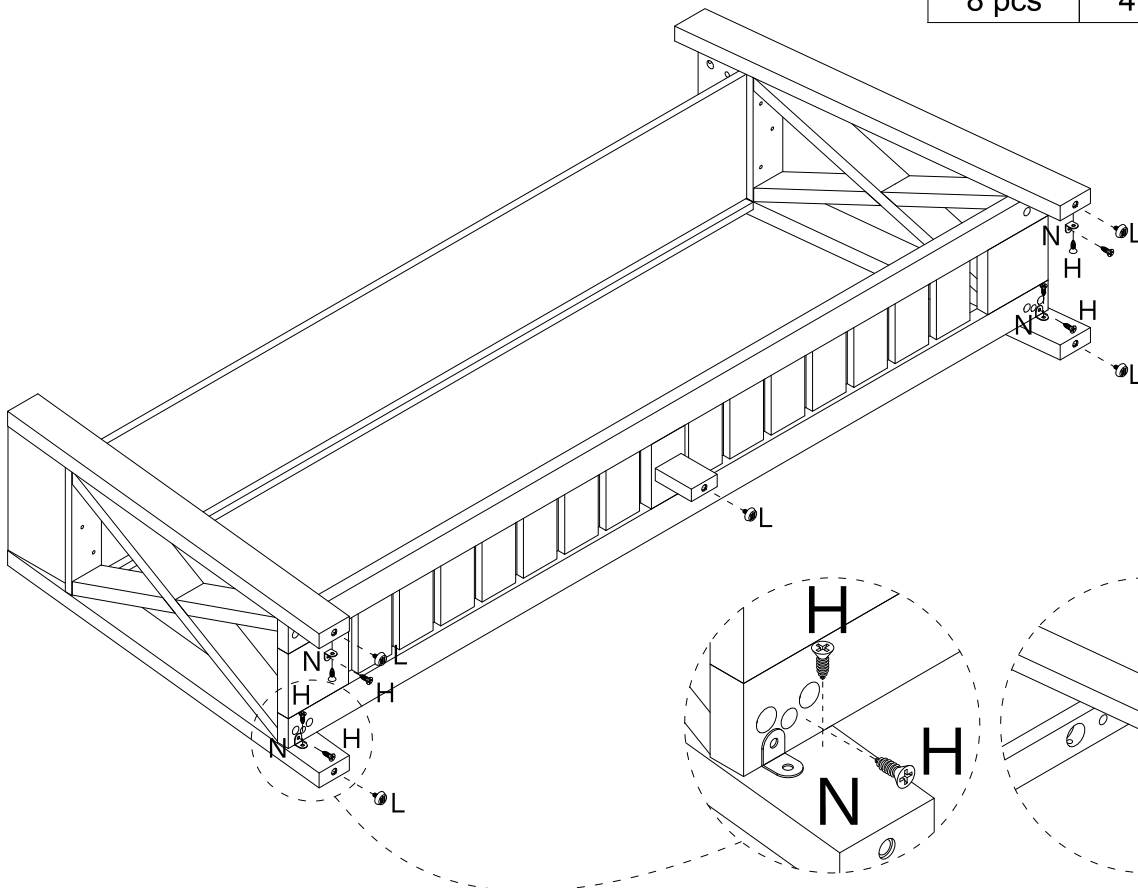

22

H	N	L
		
Ø3.5x14mm		M6x14mm
8 pcs	4 pcs	5 pcs



23

H	I-1
	
Ø3.5x14mm	
8 pcs	4 pcs

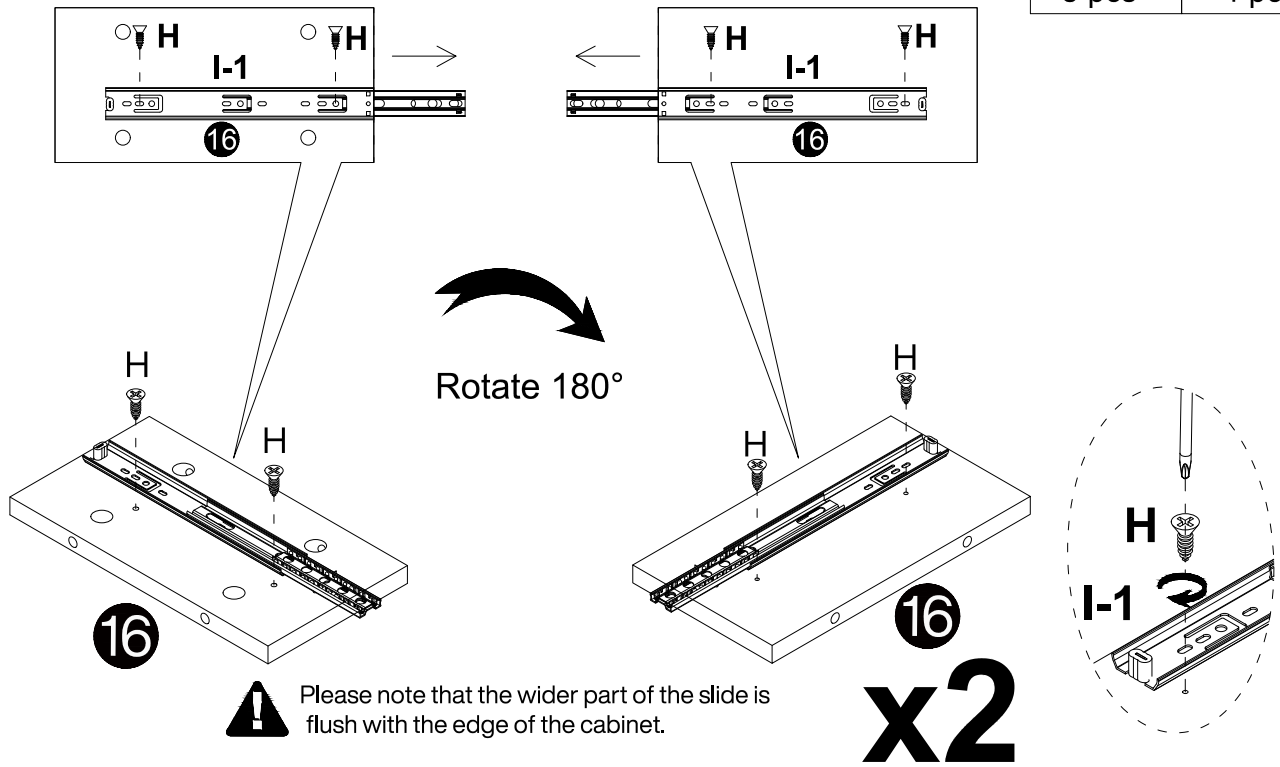

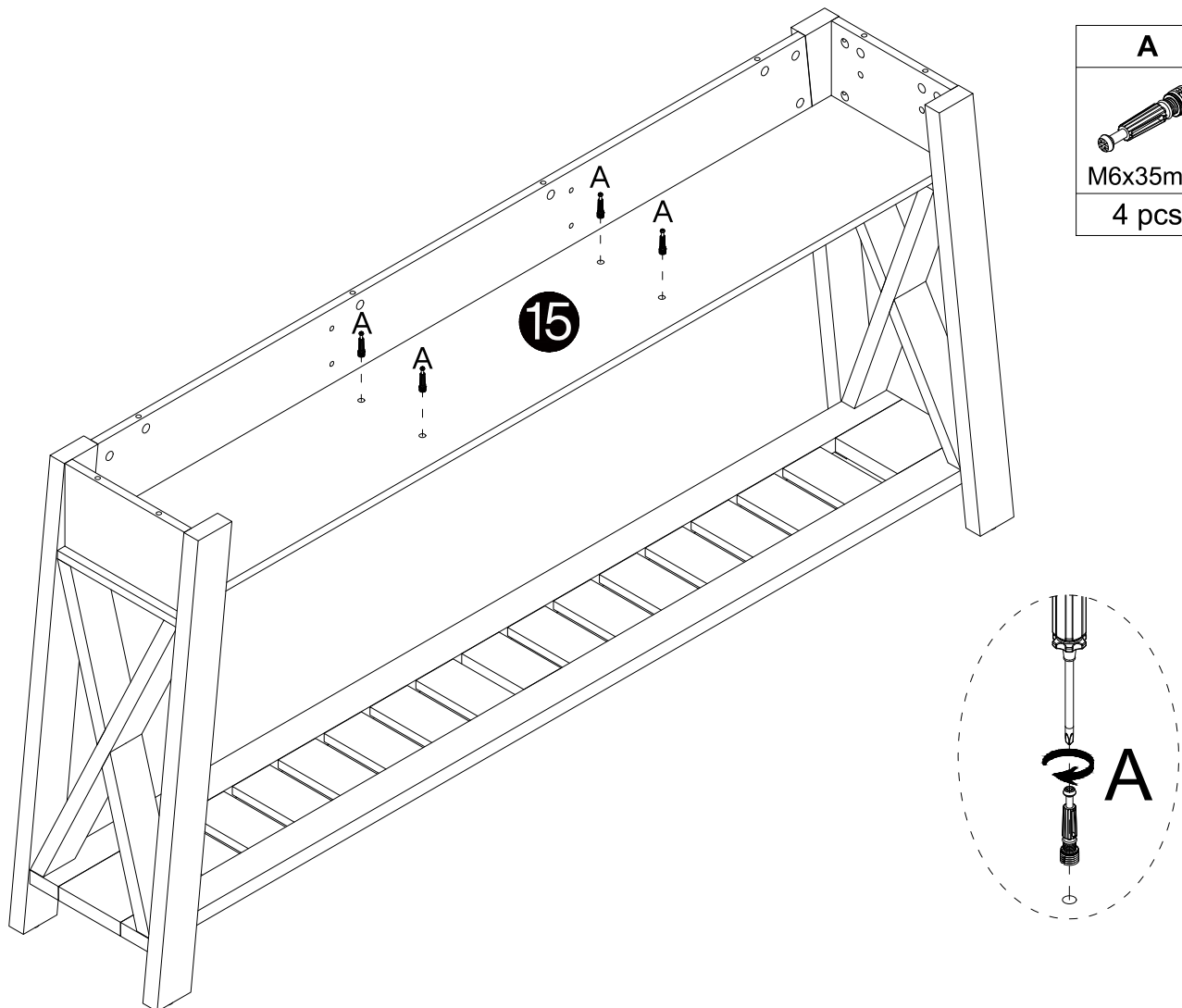

24

A

M6x35mm
4 pcs

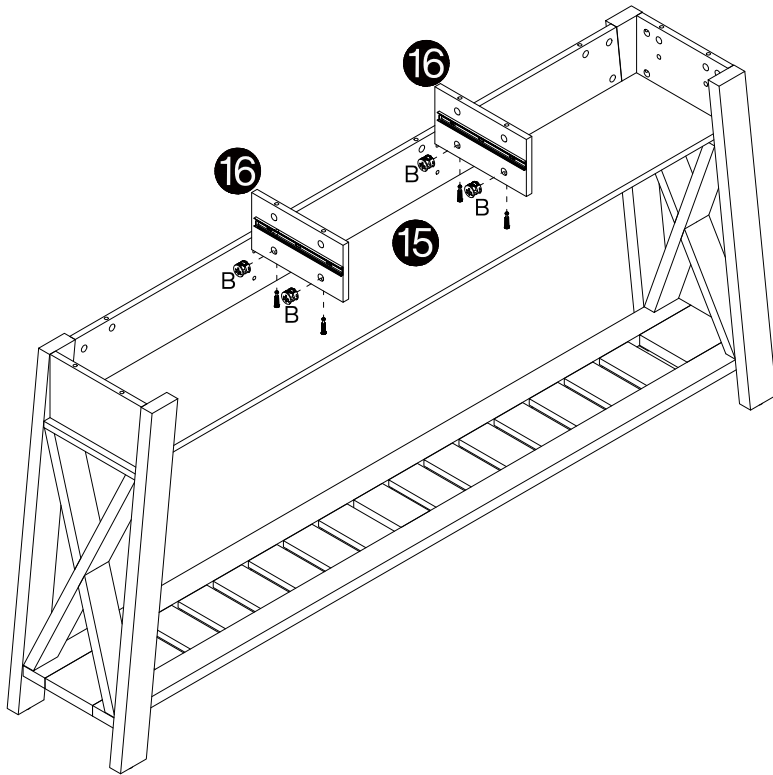

25

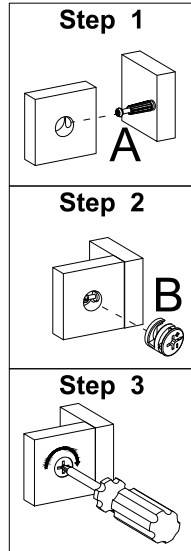

B

Ø15x12mm
4 pcs

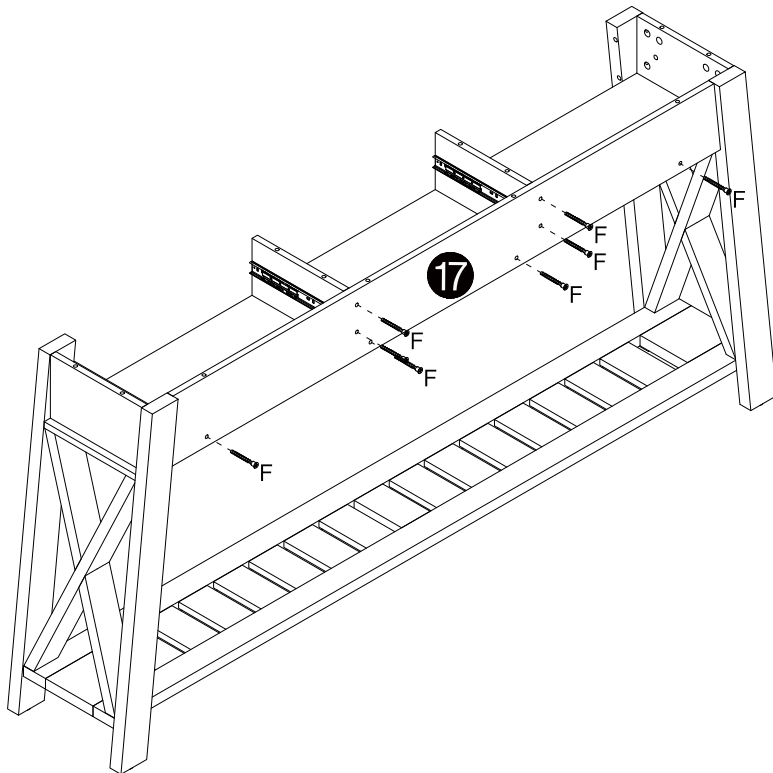

26

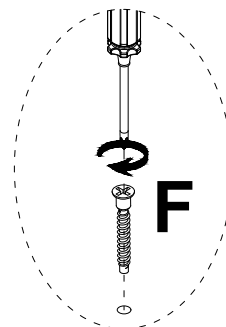

F

Ø7x38mm
8 pcs

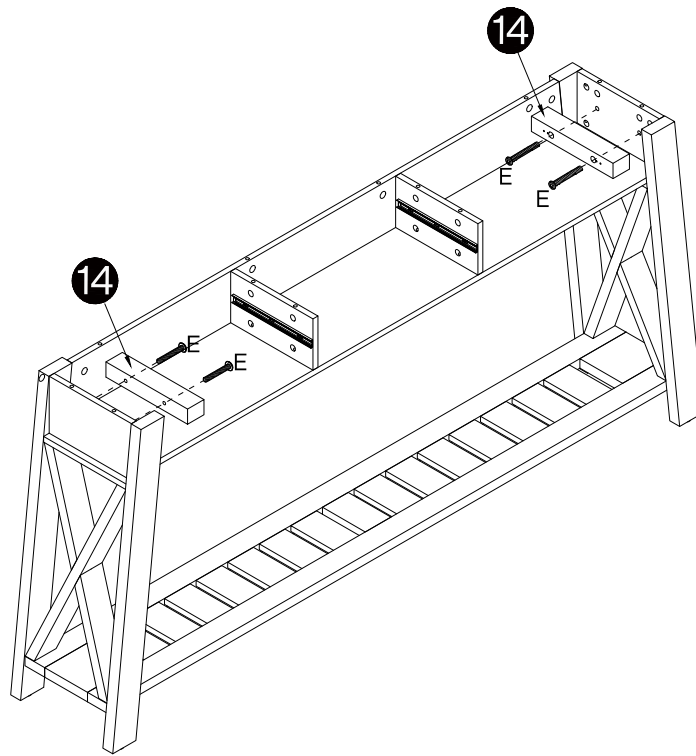

27



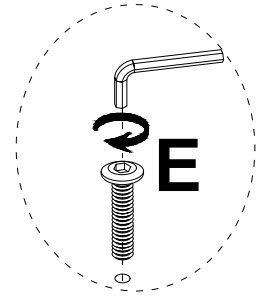

E

M6x45mm
4 pcs

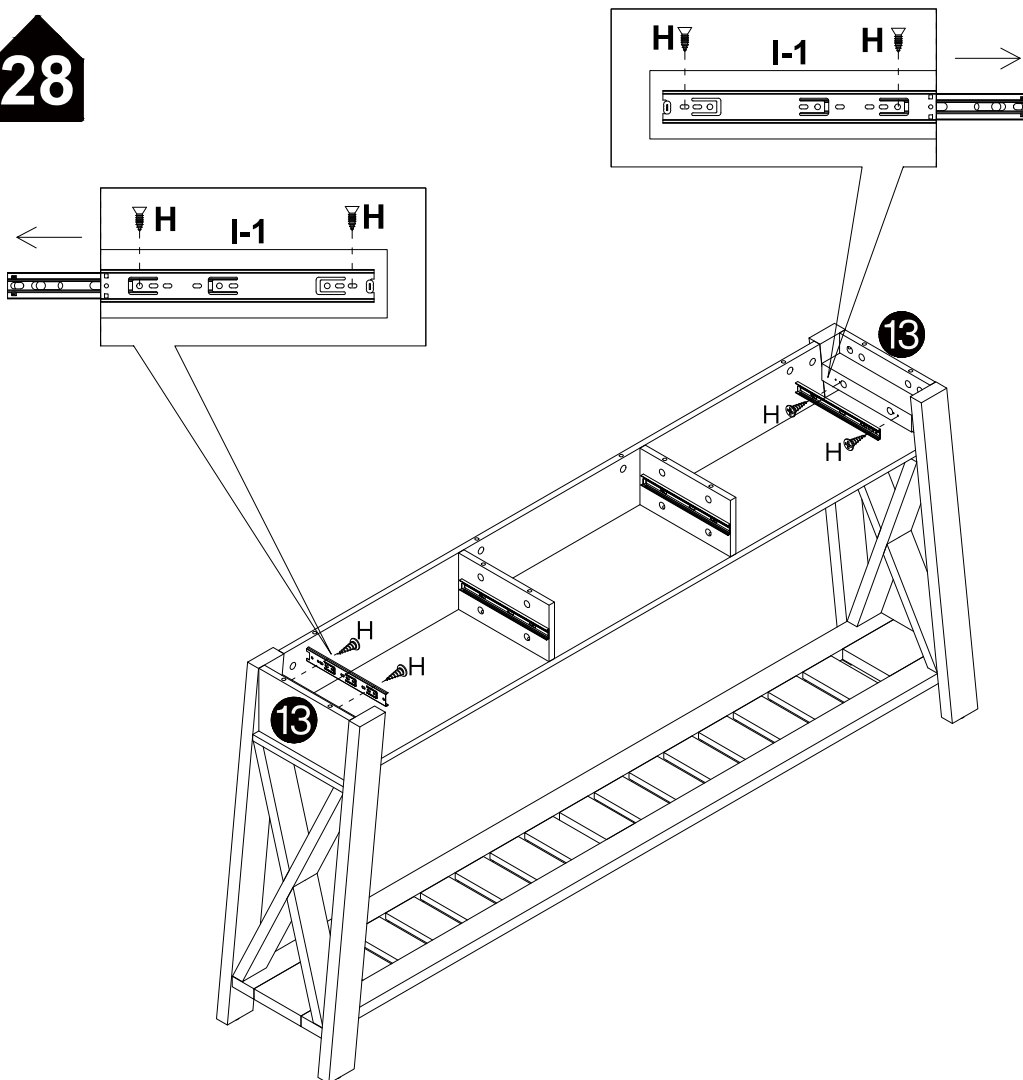

28



H	I-1
	
Ø3.5x14mm	
4 pcs	2 pcs

29

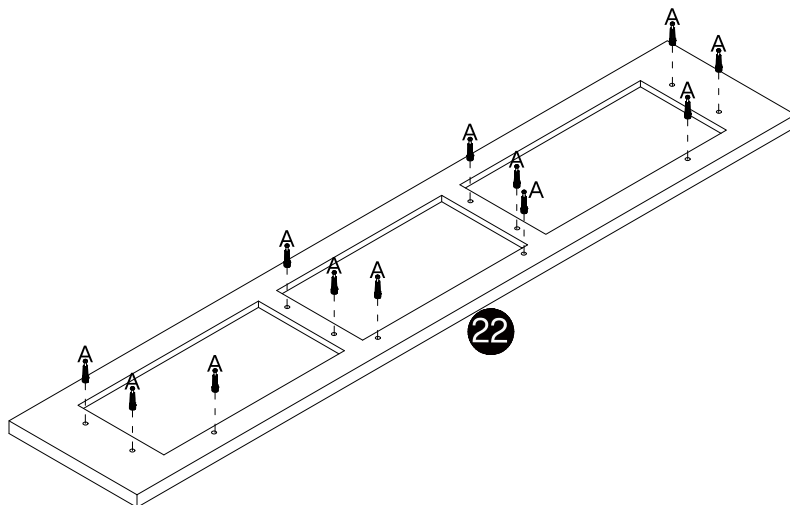

A



M6x35mm

12 pcs

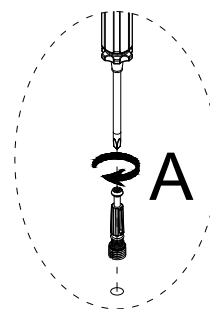

30

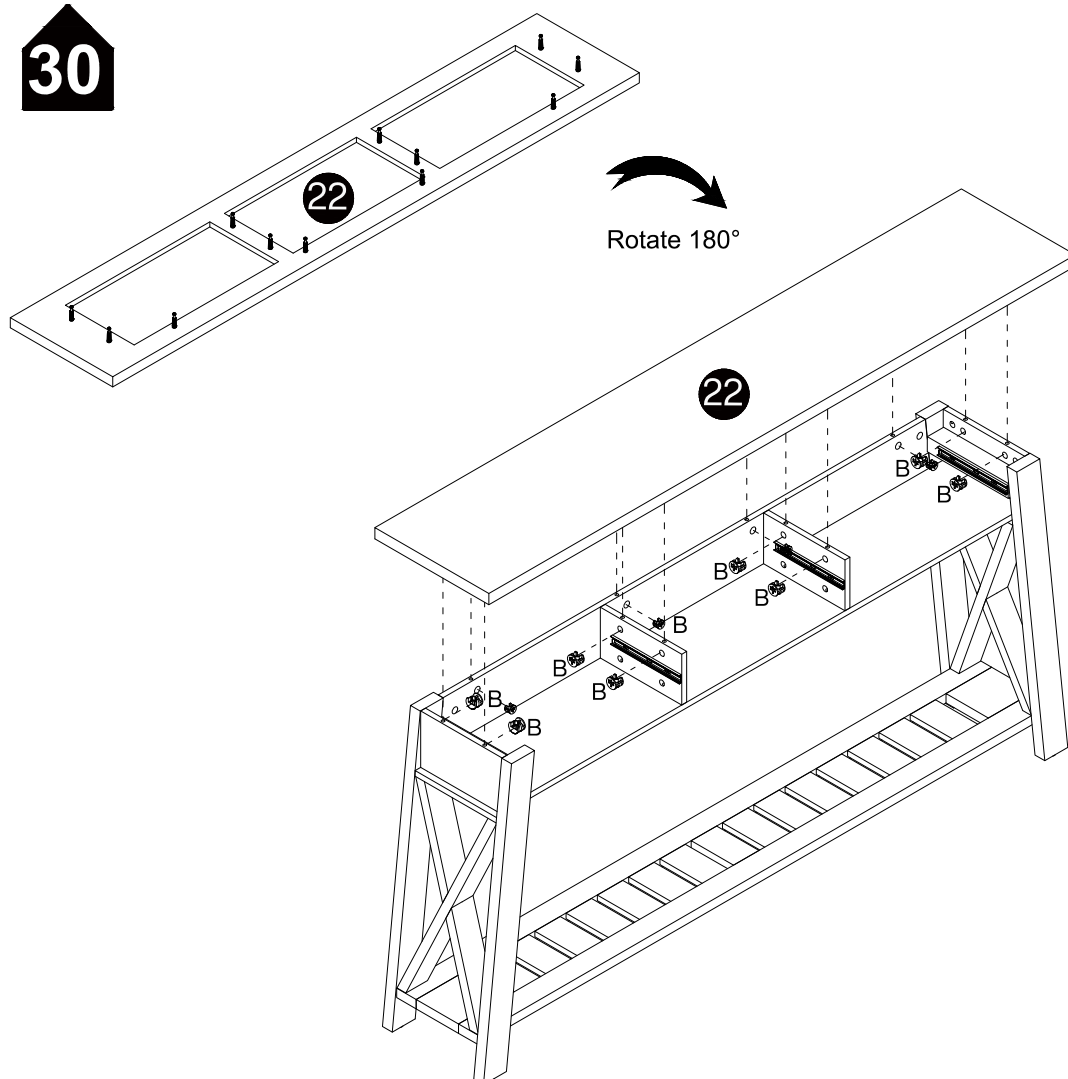

B



Ø15x12mm

12 pcs

Step 1

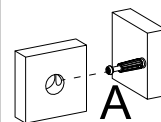

A

Step 2

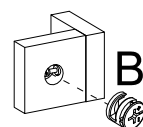

B

Step 3

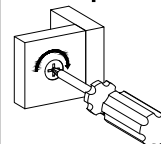

31

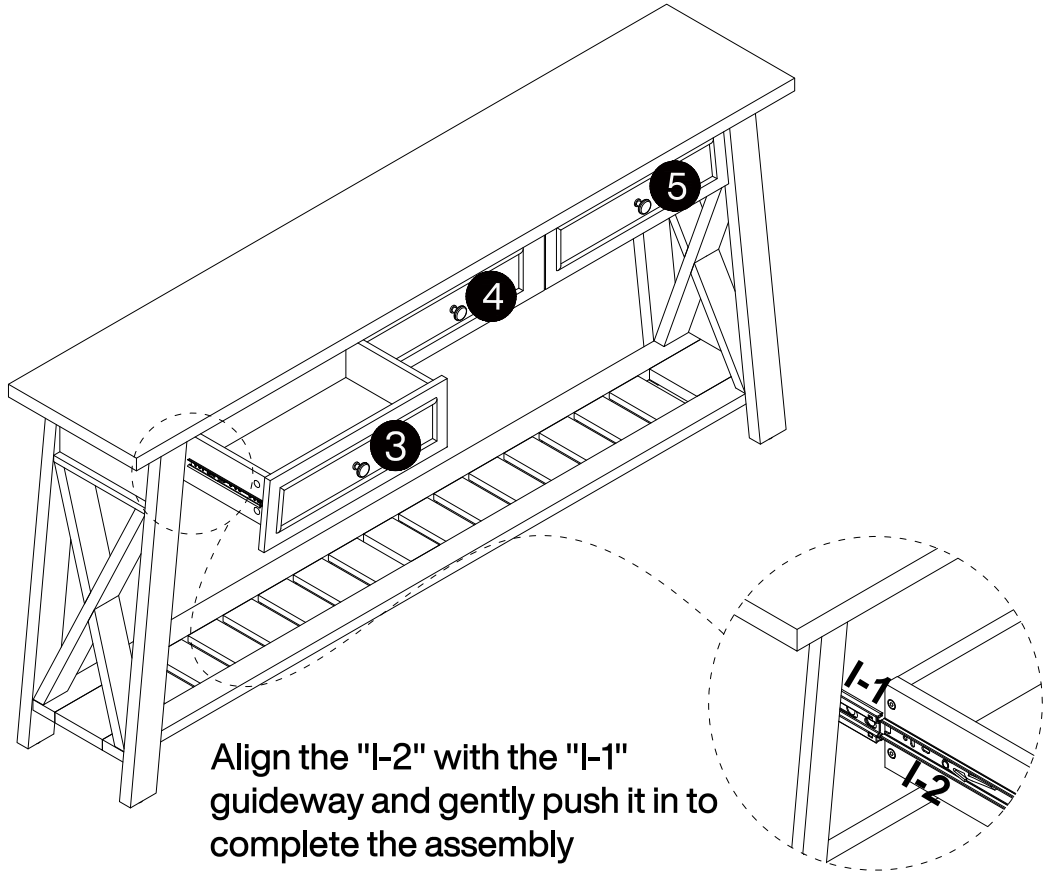

32

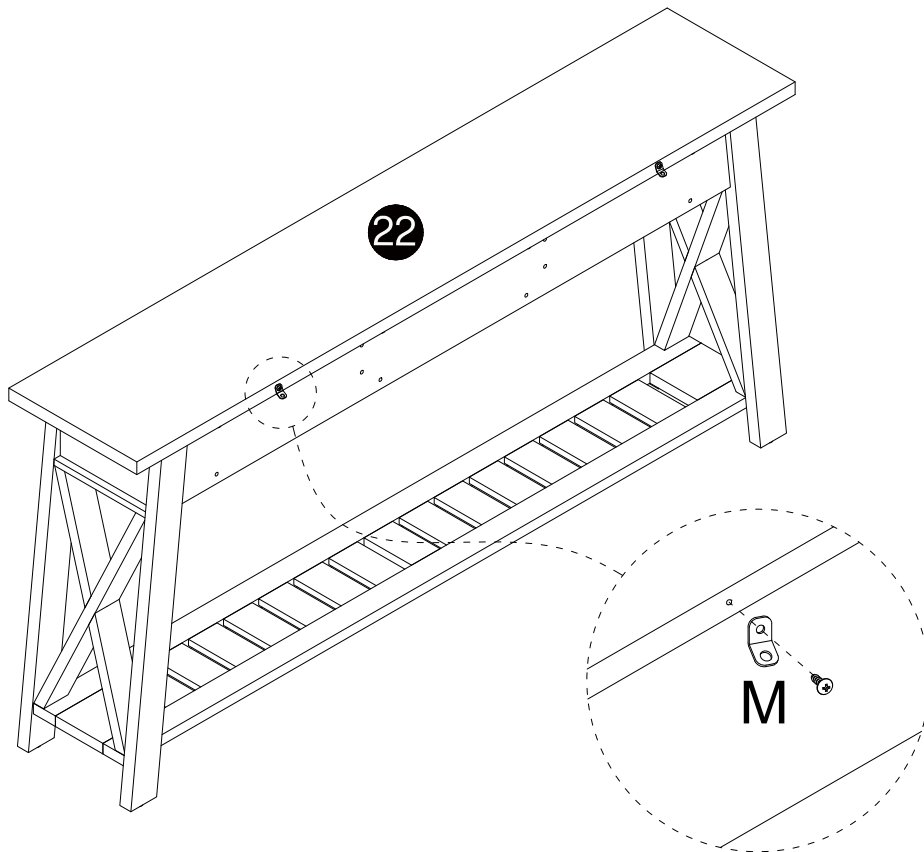

M
2pcs

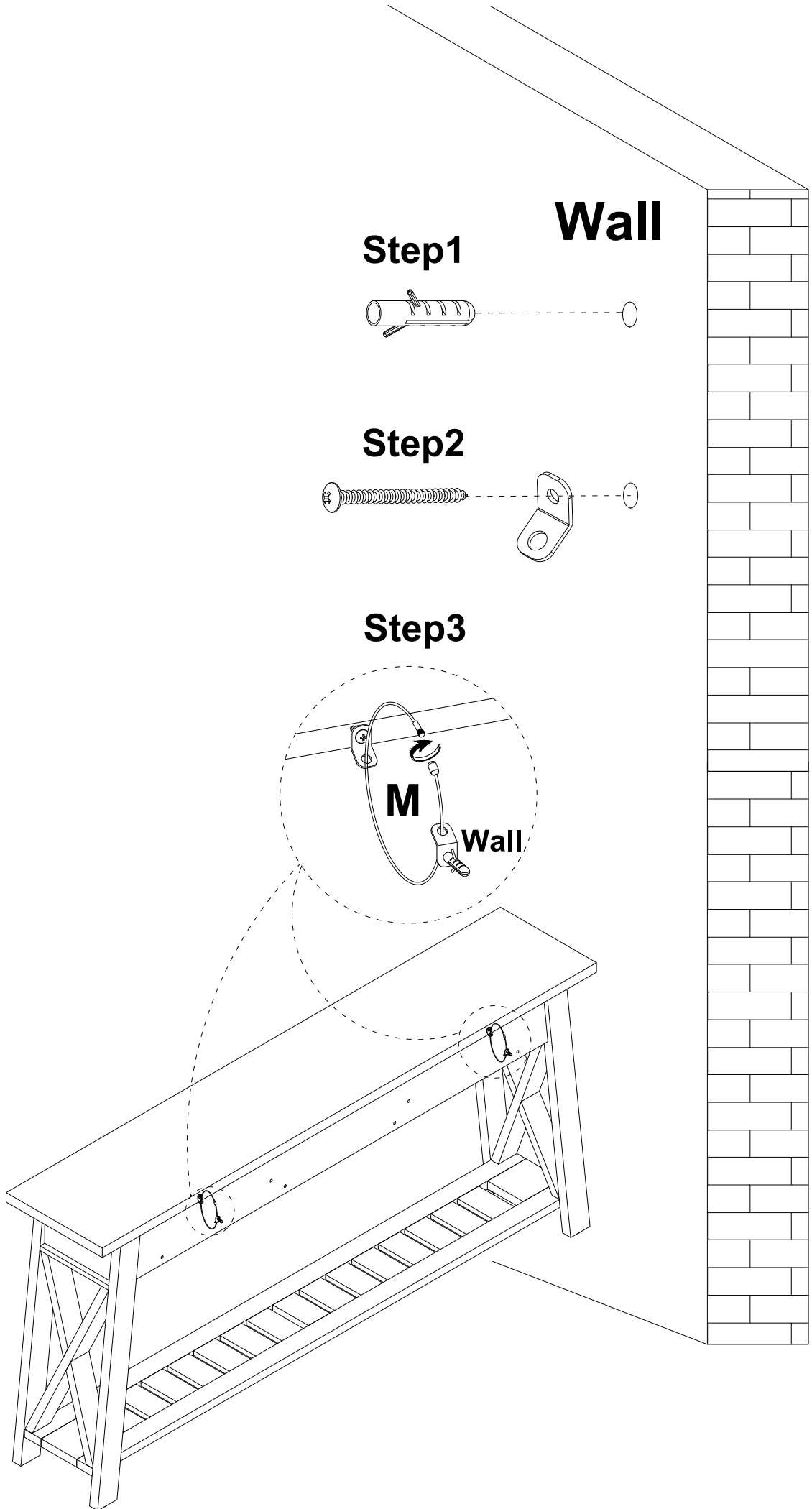

Thank you for your support !

