

Assembly Instructions

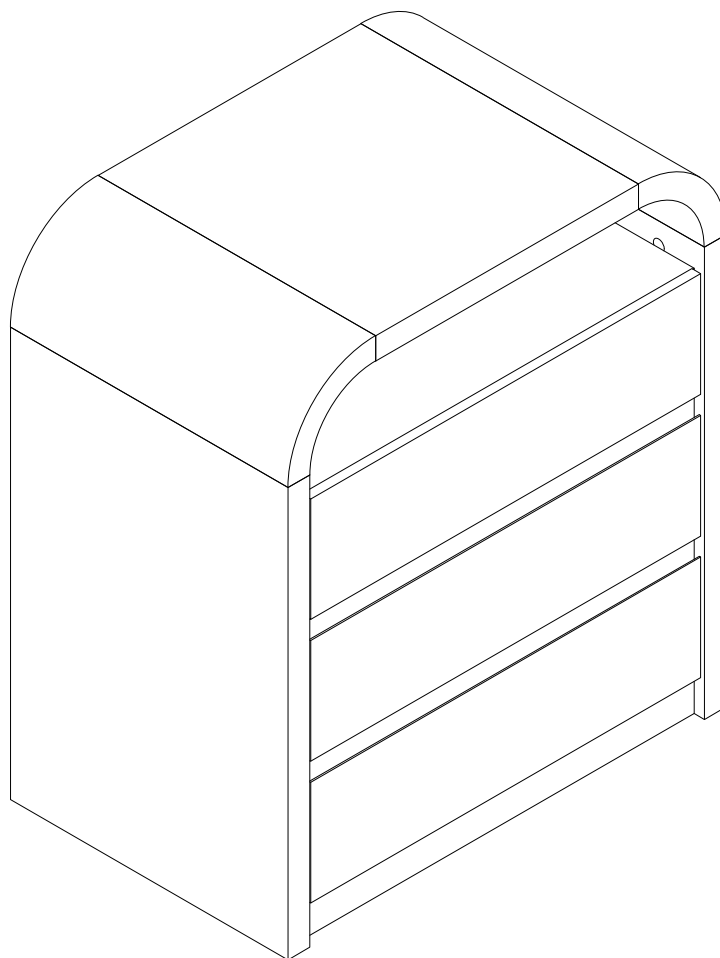

Before Assembly

Tips Before Your Start:

- Remove all wrapping material, including staples & packing straps before you start to assemble.
- DO NOT tighten all screws and bolts until the assembly is completely assembled.
- Keep all hardware parts out of reach of children.

QUICKFIT

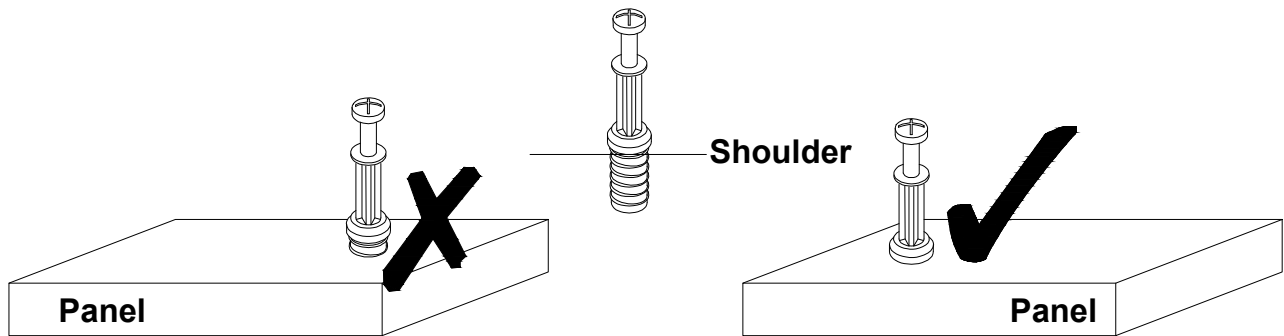

Tighten quickfit until shoulder is flush with panel. Do not overtighten or undertighten.

CAM LOCK

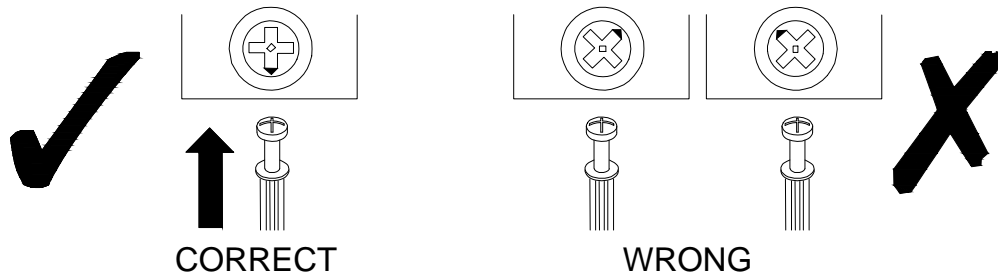

When fitting a cam lock, ensure the starting position is correct before inserting the connecting QUI CKFIT

Quickfit head should be in the centre of the cam lock when the two panels are joined.

Cam lock should be inserted before quickfit.

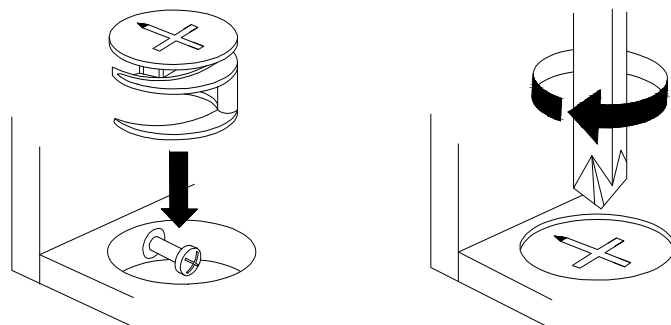

Turn cam lock clockwise to tighten.

Before Assembly

Tips Before Your Start

How to separate the drawer slider:

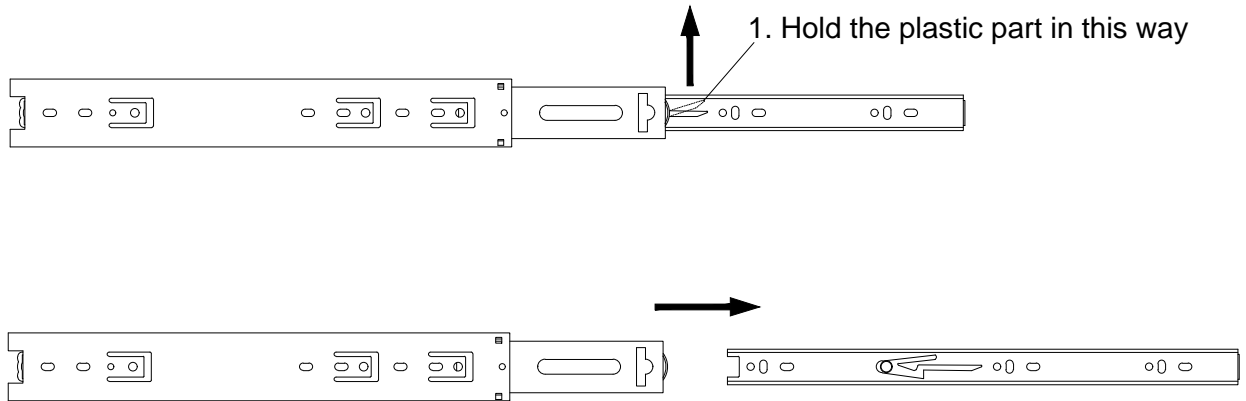

2. Pull out the inner slider for drawer box fixing

Drawer Front Alignment

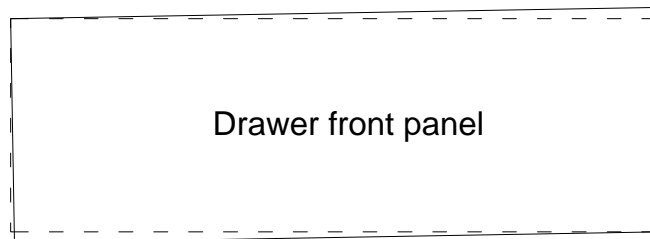



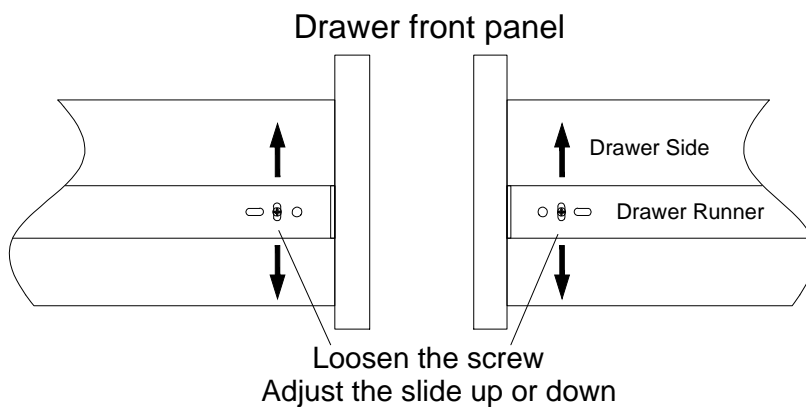



If the drawer front panel is NOT level after being assembled, then...

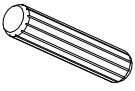
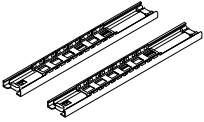

Loosen the screws on the left and right hand side, then adjust the drawer slide up or down, until the drawer fronts are even/level, then tighten the screws.

Part List

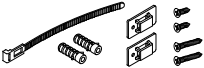
<p>No. A Quantity: 44 Pcs Cam Lock Dowel 8*28mm</p> 	<p>No. B Quantity: 44 Pcs Cam 15</p> 	<p>No. C Quantity: 44 Pcs Sticker Ø20</p> 	<p>No. D Quantity: 6 Pcs Dowel 8*30mm</p> 
<p>No. E Quantity: 3 Sets Drawer Slider 10"</p> 	<p>No. F Quantity: 24 Pcs Screw M3.5*12mm</p> 	<p>No. G Quantity: 12 Pcs Screw M4*30mm</p> 	<p>No. H Quantity: 8 Sets Plastic Wedge</p> 
<p>No. I Quantity: 4 Pcs Foot Pad Ø15</p> 	<p>No. J Quantity: 1 Sets Anti-falling Parts</p> 		

Product structure

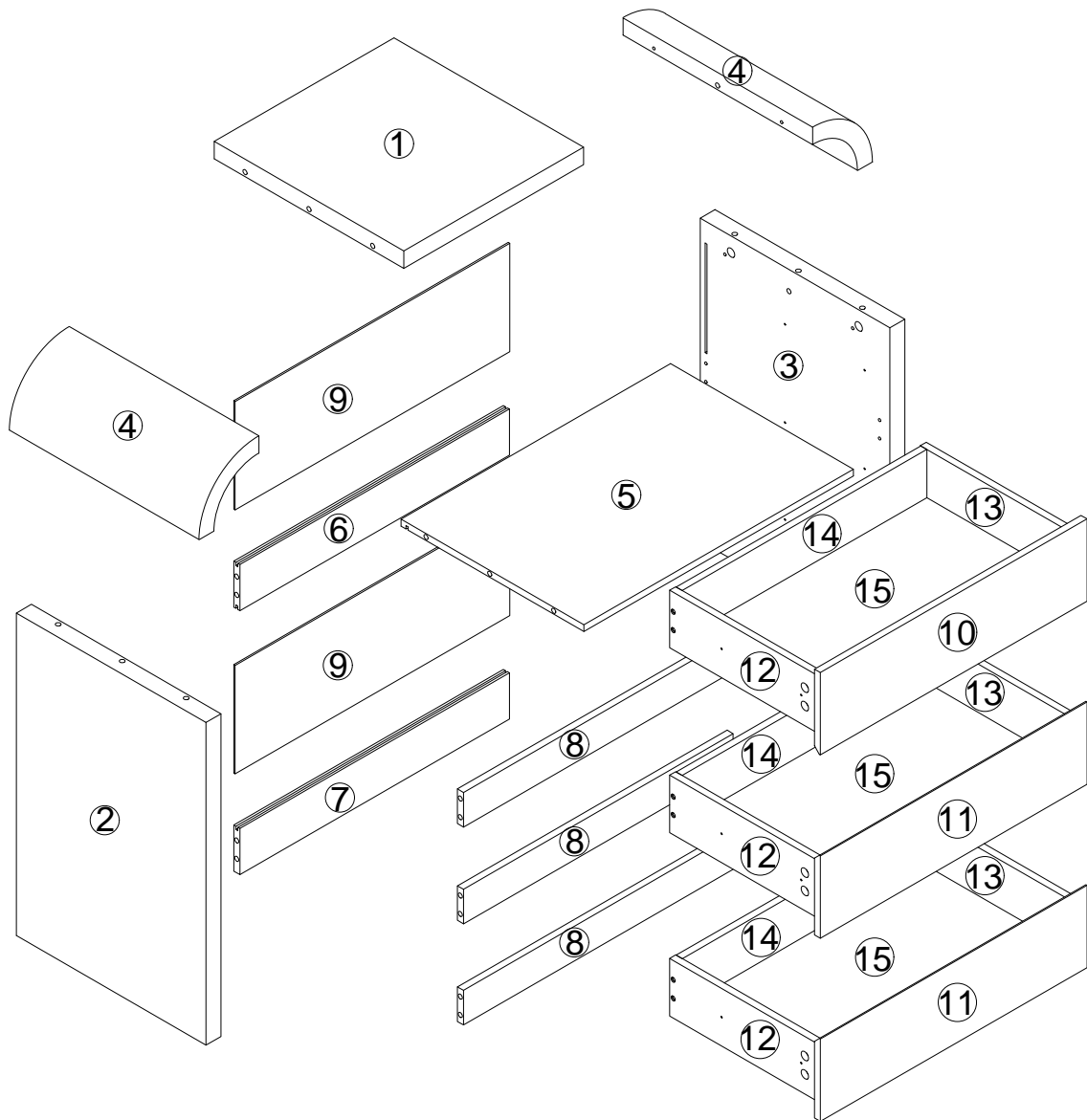

STEP 1



The first screw hole should corresponded with the board location hole

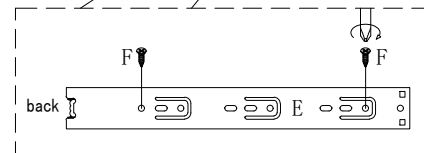
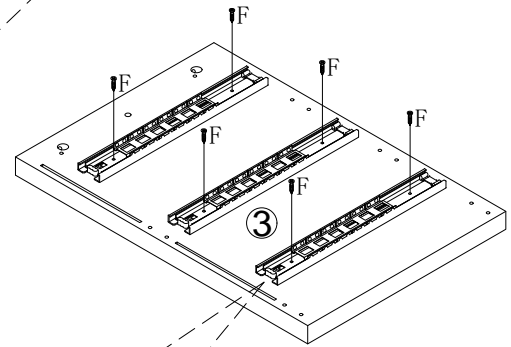
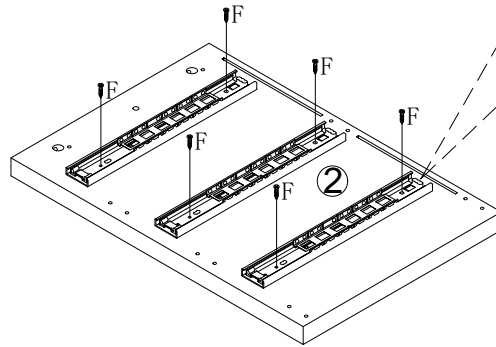
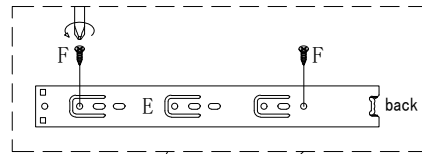

No. E
Quantity: 3 Sets
10"

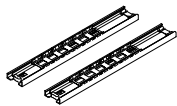

No. F
Quantity: 12 Pcs
M3.5*12mm



STEP 2

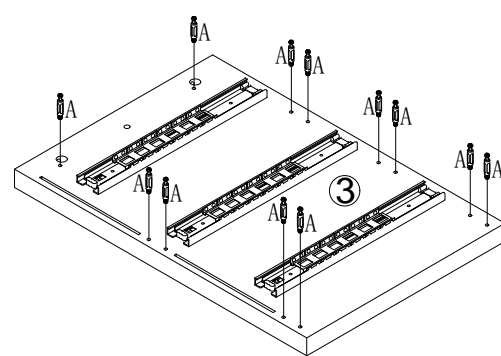
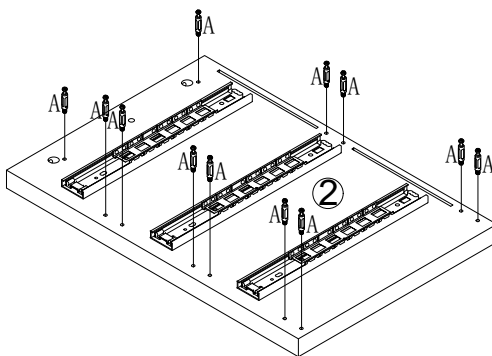

No. A
Quantity: 24 Pcs
8*28 mm



STEP 3

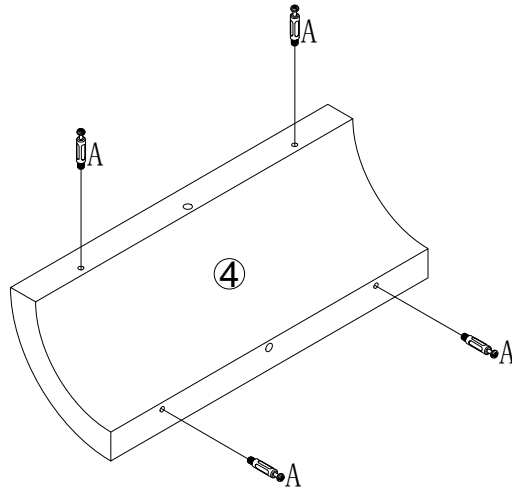

No. A
Quantity: 8 Pcs
8*28 mm



x2

STEP 4

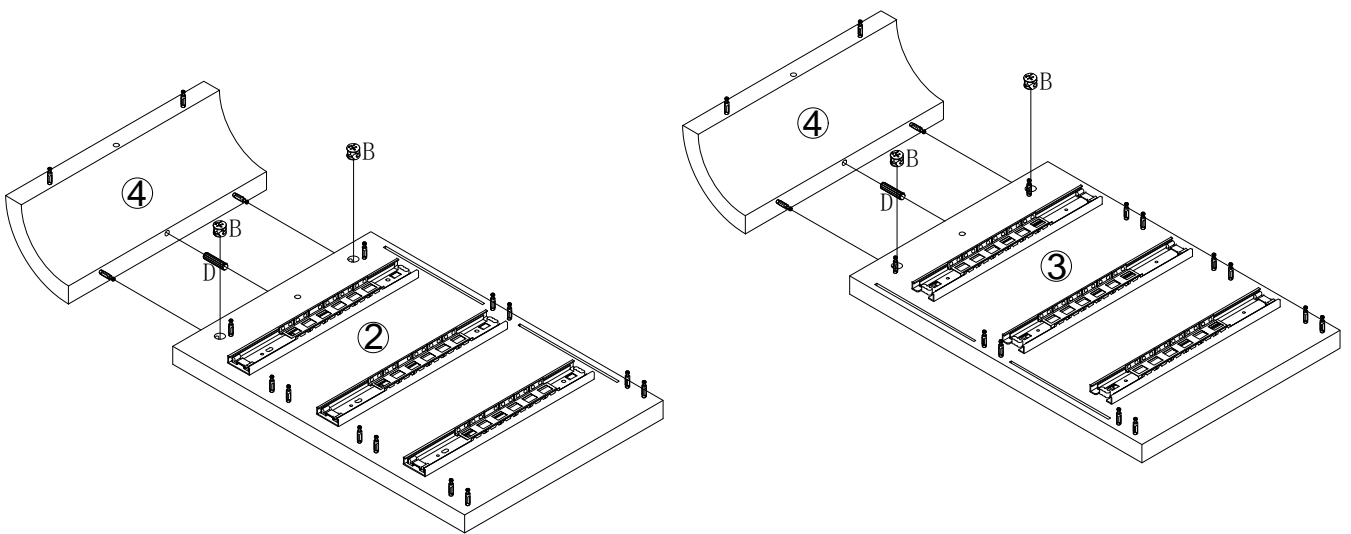

No. B
Quantity: 4 Pcs
Ø15



No. D
Quantity: 2 Pcs
8*30mm

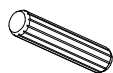

STEP 5

Pay attention to the direction during installation

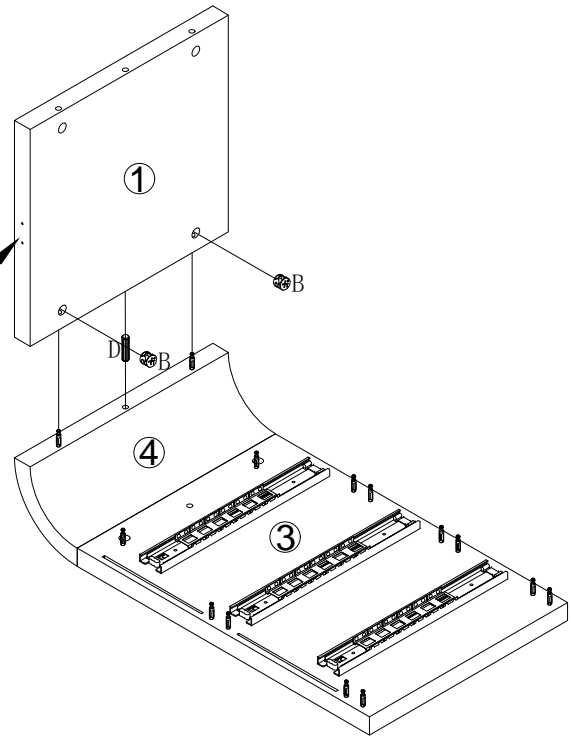

No. B
Quantity: 2 Pcs
Ø15



No. D
Quantity: 1 Pcs
8*30mm

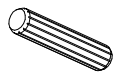

STEP 6

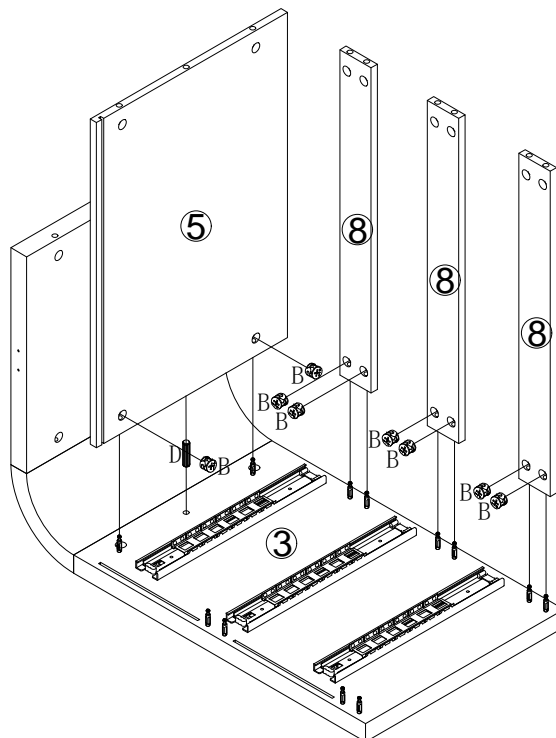

No. B
Quantity: 8 Pcs
Ø15



No. D
Quantity: 1 Pcs
8*30mm

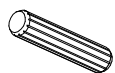

STEP 7

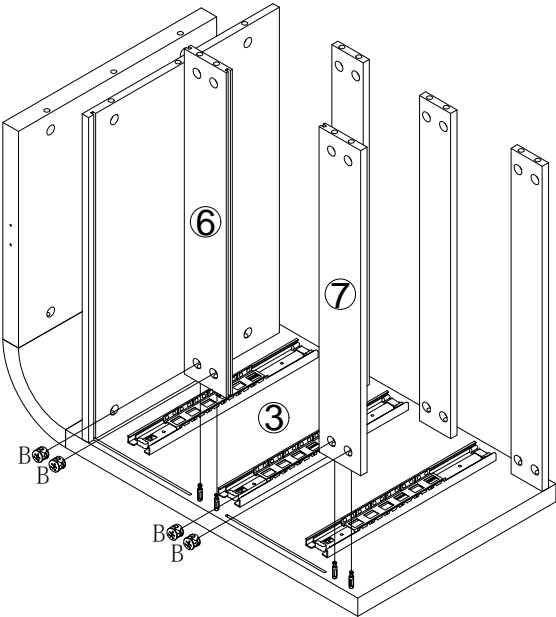

No. B
Quantity: 4 Pcs
Ø15



STEP 8

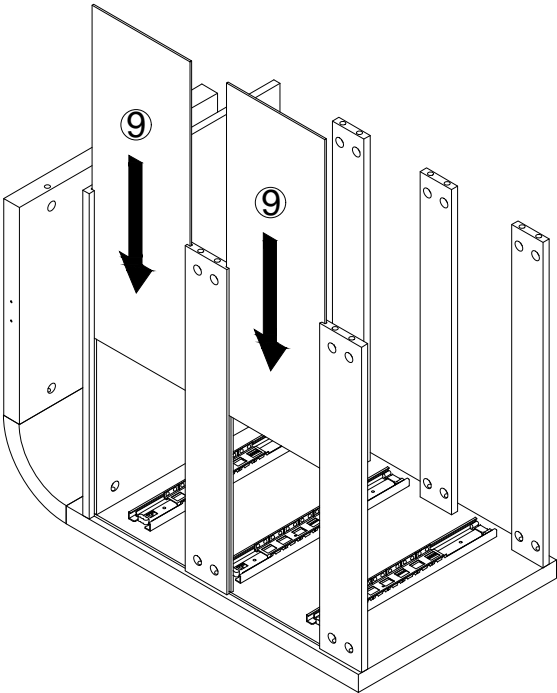

STEP 9



Note: This step requires two people to cooperate to complete the installation, as one person may damage parts during the installation process.

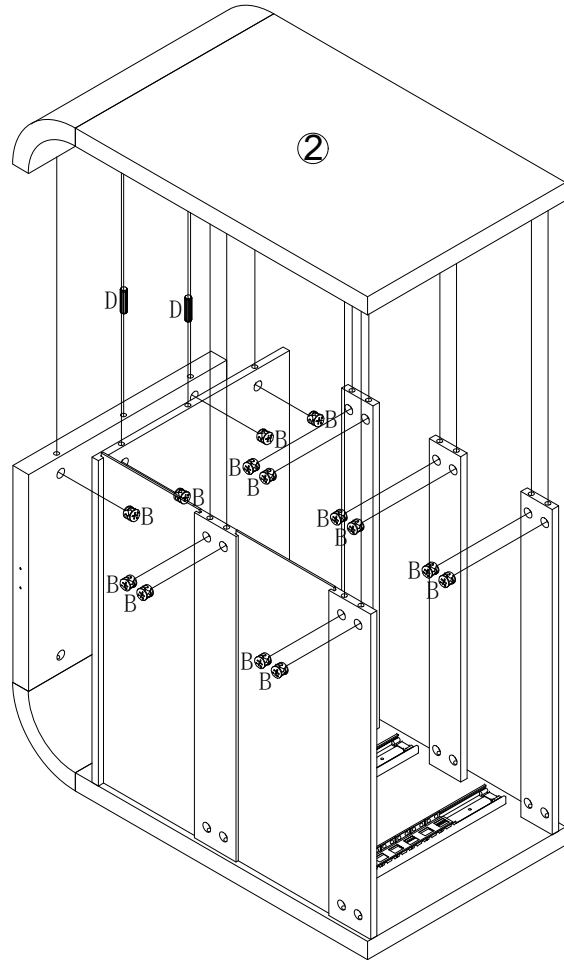

No. B

Quantity: 14 Pcs
Ø15



No. D

Quantity: 2 Pcs
8*30mm

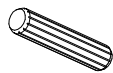

STEP 10

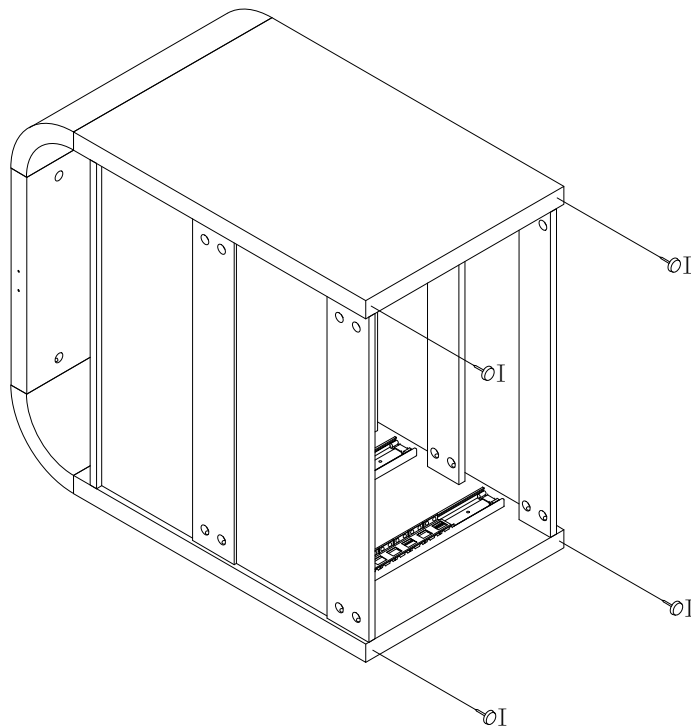

No. I

Quantity: 4 Pcs
Ø15



STEP 11

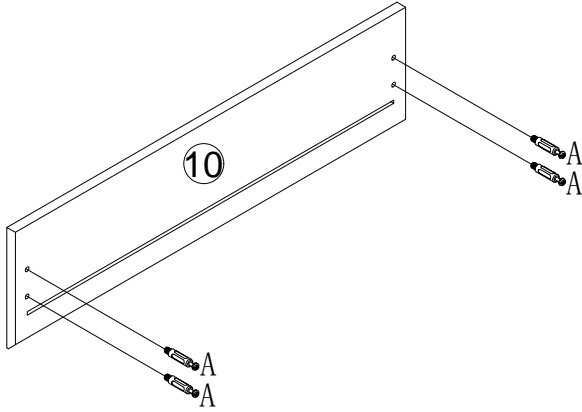

x1

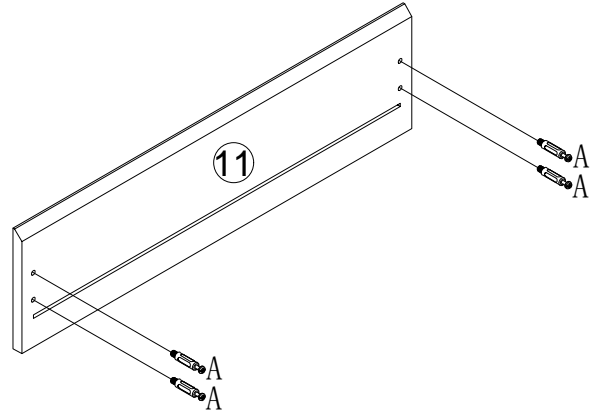

x2

No. A
Quantity: 12 Pcs
8*28 mm



STEP 12

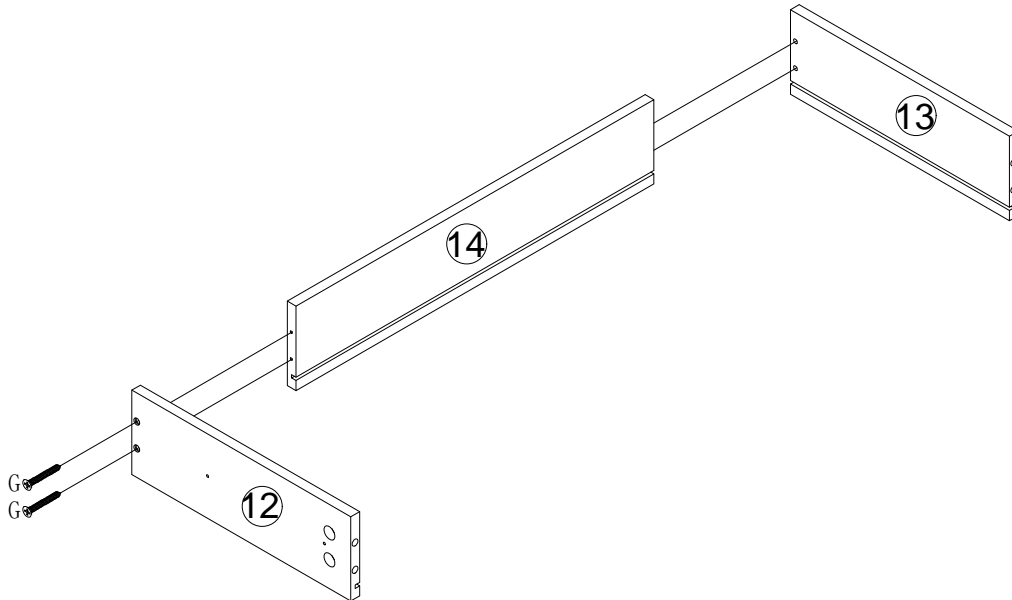

x3

No. G
Quantity: 12 Pcs
M4*30mm

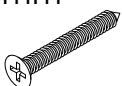

STEP 13

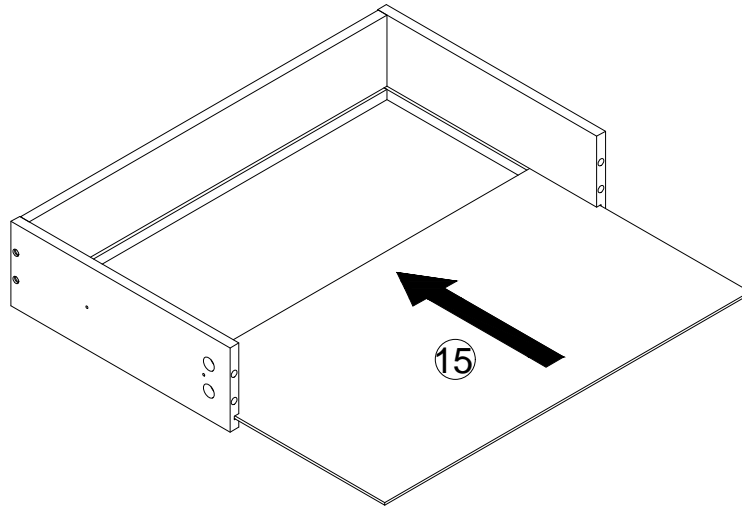

x3

STEP 14

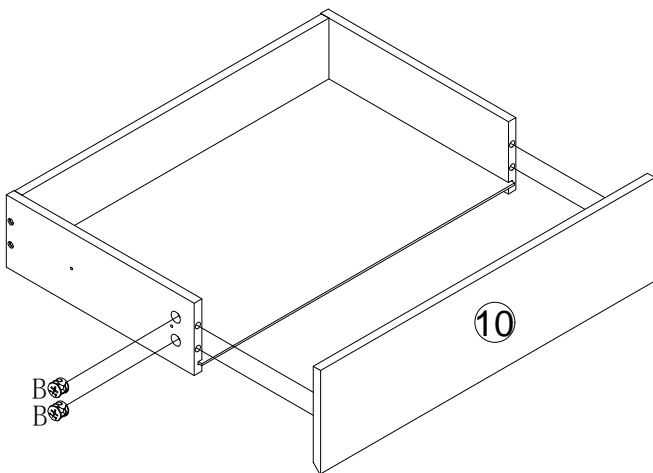

x1

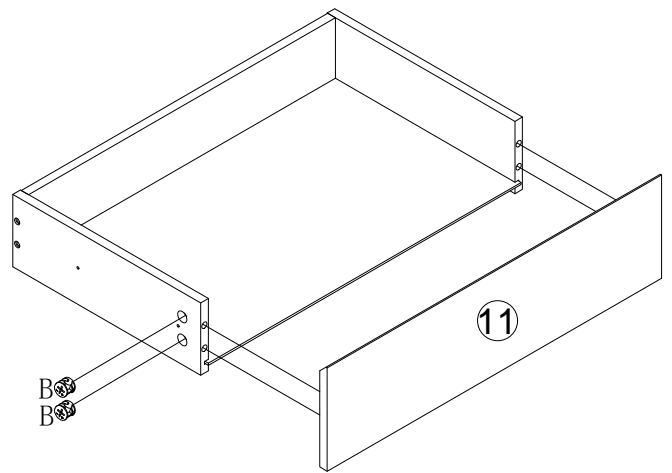

x2

No. B
Quantity: 12 Pcs
Ø15



STEP 15



The first screw hole should corresponded with the board location hole

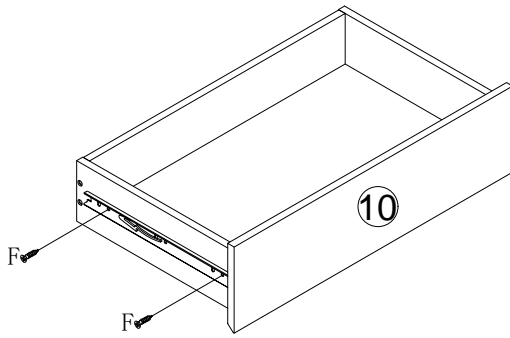

x1

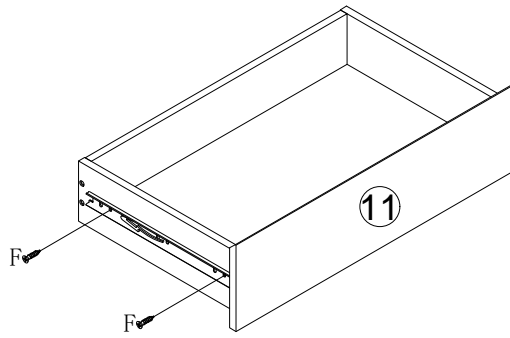

x2

No. E
Quantity: 3 Sets
10"

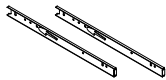

No. F
Quantity: 12 Pcs
M3.5*12mm



STEP 16

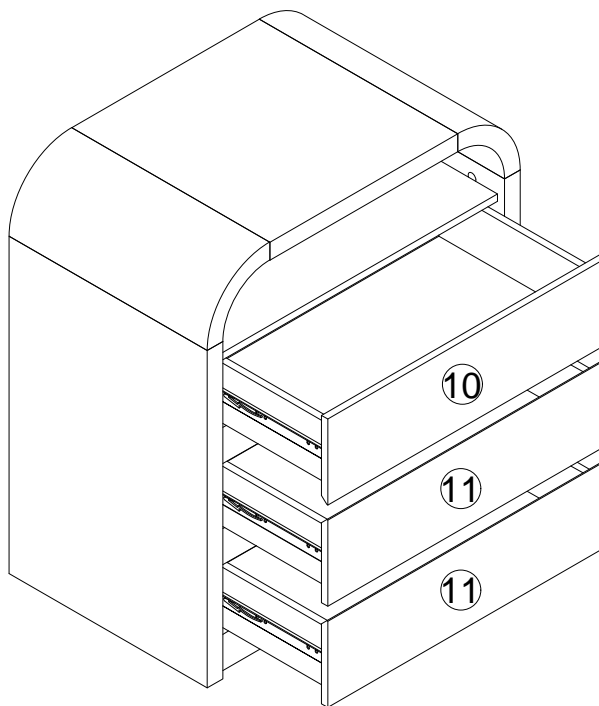

STEP 17

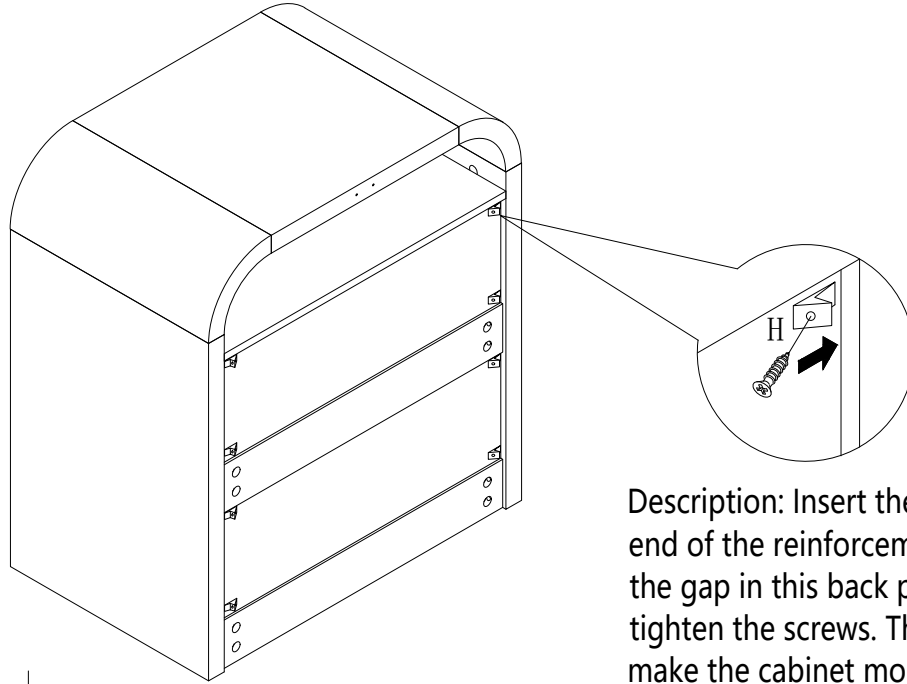

Description: Insert the thinner end of the reinforcement into the gap in this back panel, then tighten the screws. This will make the cabinet more stable.

No. H
Quantity: 8 Sets

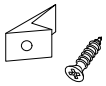

STEP 18

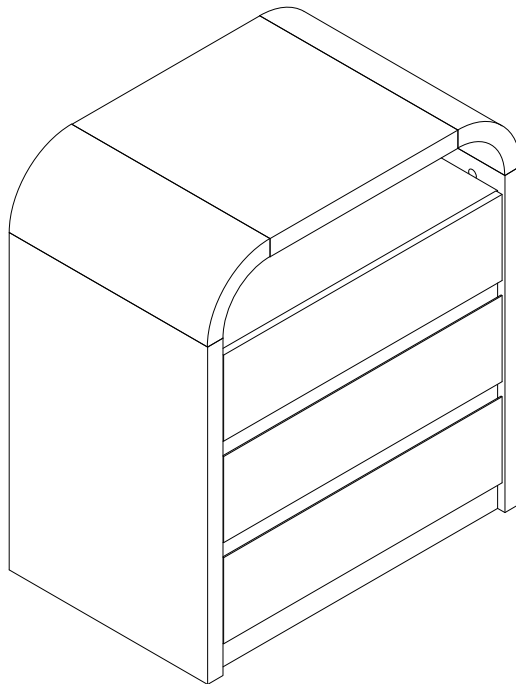

STEP 19

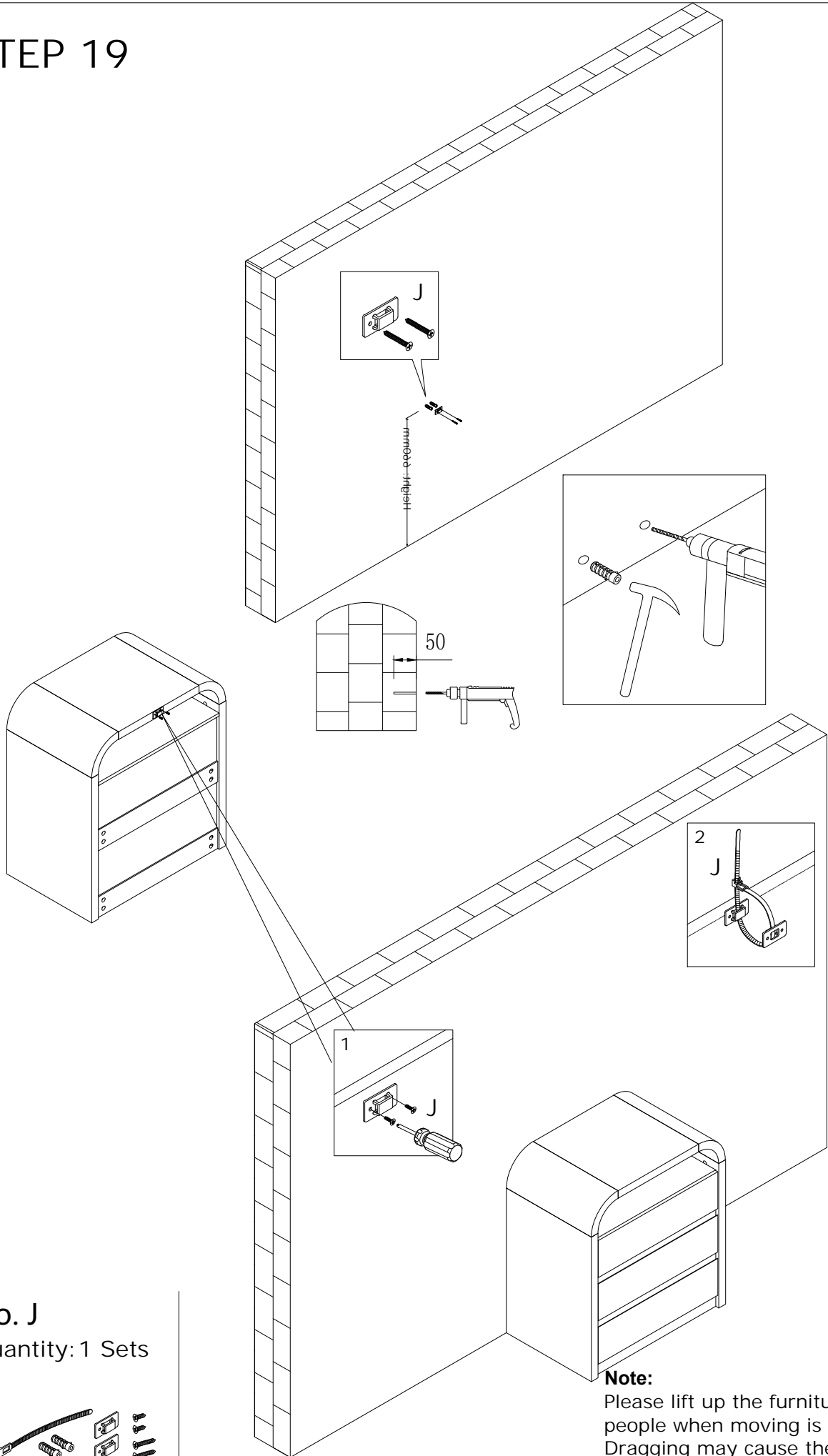

No. J
Quantity: 1 Sets

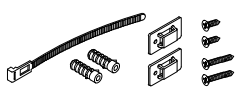

Note:
Please lift up the furniture by two people when moving is needed.
Dragging may cause the legs failure.