



















ASSEMBLY INSTRUCTI

NO	PARTLIST	QTY
1	 BACK PANEL 1PC	1PC
2	 SIDE PANEL L&R 2PCS	2PCS
3	 SUPPORT (LEFT) 1PC	1PC
4	 SUPPORT (RIGHT) 1PC	1PC
5	 LEG (LEFT) 2PCS	2PCS
6	 LEG (RIGHT) 2PCS	2PCS
7	 SIDE RAIL 2PCS	2PCS
8	 SLAT 4SETS	4SETS
9	 TRUNDLE FRONT & BACK RAIL 2PCS	2PCS
10	 TRUNDLE SIDE RAIL 2PCS	2PCS
11	 CASTER 4PCS	4PCS
ITEM	HARDWARE	QTY
A	 JCB SCREW M8 x 20MM 14PCS	14PCS
B	 JCB SCREW M6 x 16MM 8PCS	8PCS
C	 JCB SCREW M6 x 25MM 4PCS	4PCS
D	 JCB SCREW M6 x 50MM 4PCS	4PCS
E	 SCREW M4 x 32MM 16PCS	16PCS
F	 L - KEY M4 x 65MM 1PC	1PC
G	 L - KEY M5 x 65MM 1PC	1PC
H	 SPANNER 10" 1PC	1PC

STEP 1

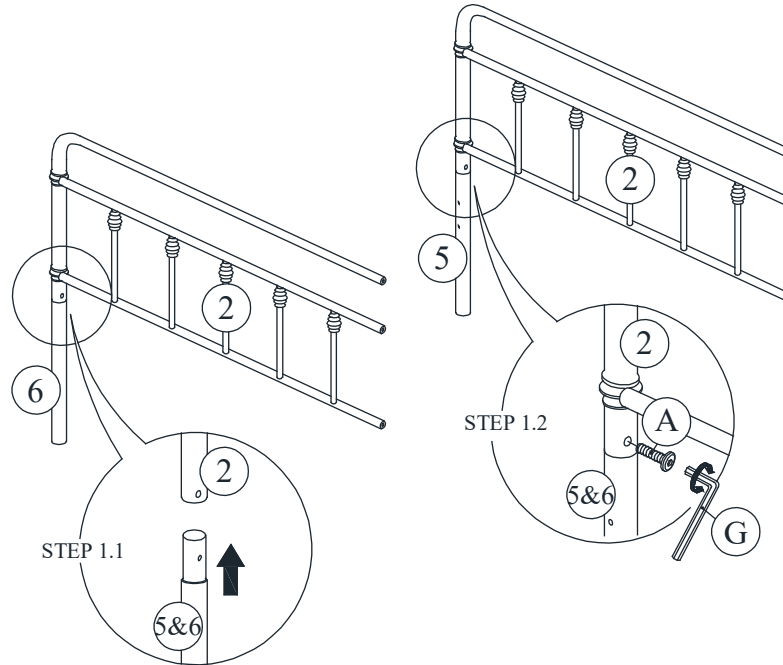

STEP 3

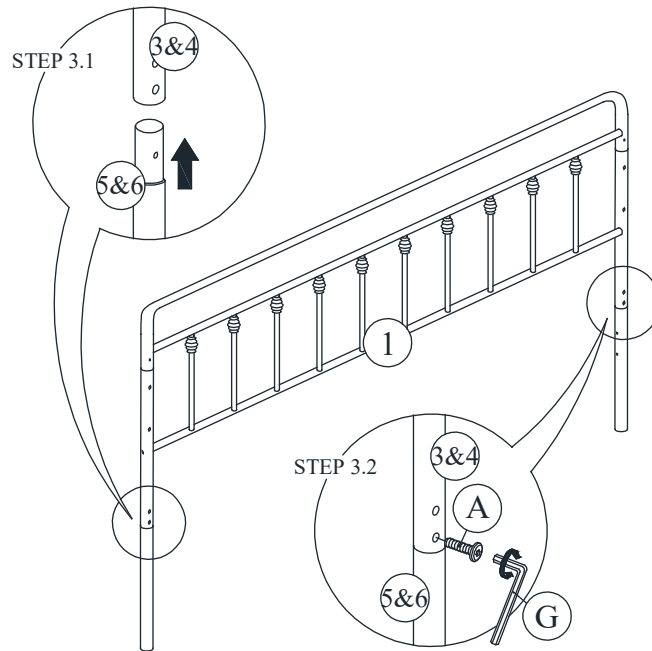

STEP 2

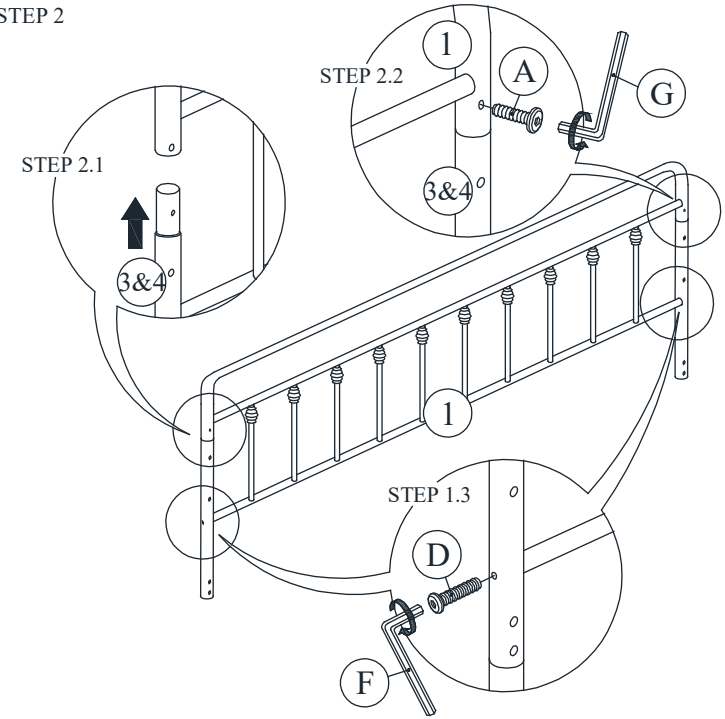

STEP 4

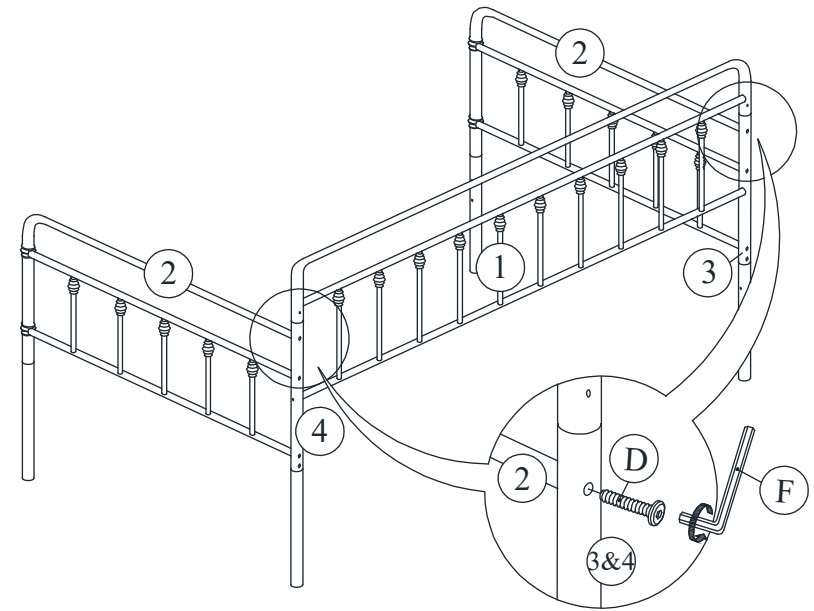

ASSEMBLY INSTRUCTION

STEP 5

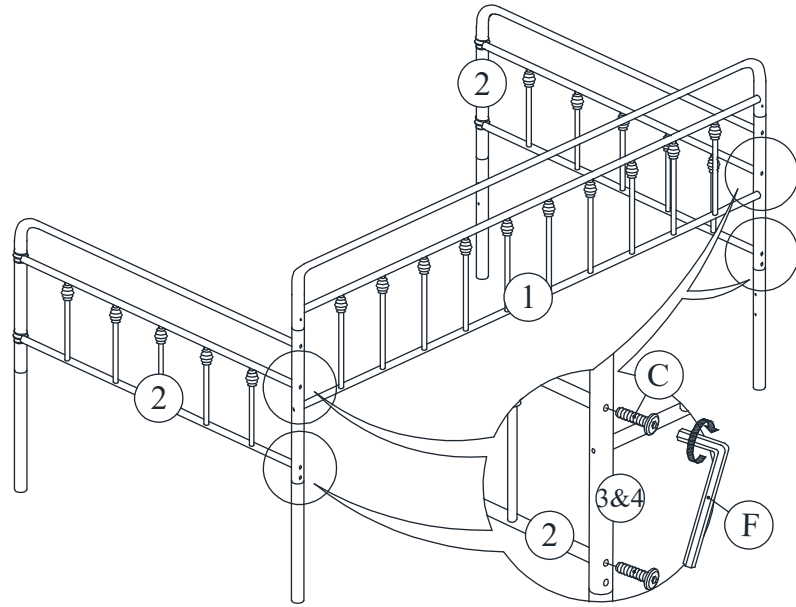

STEP 6

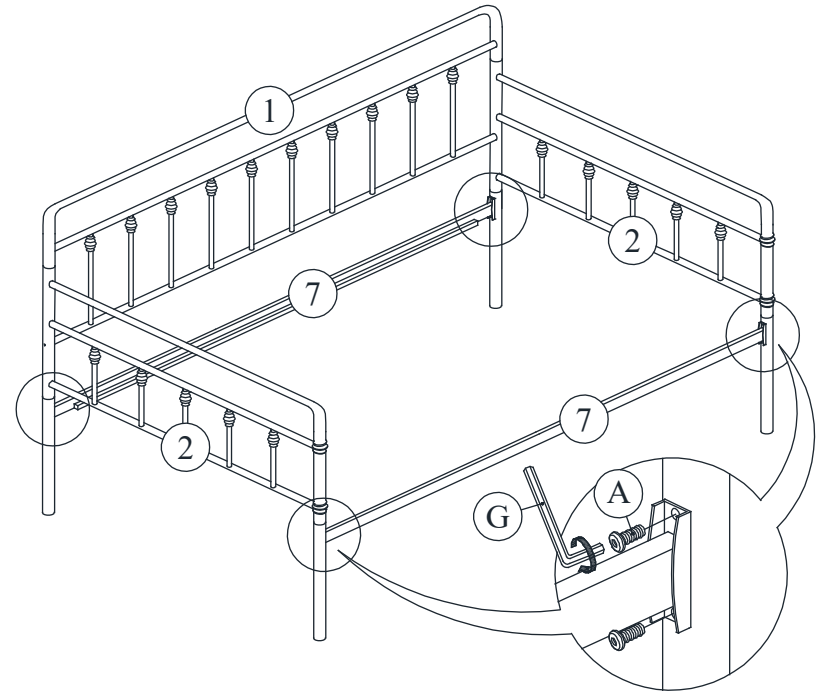

STEP 7

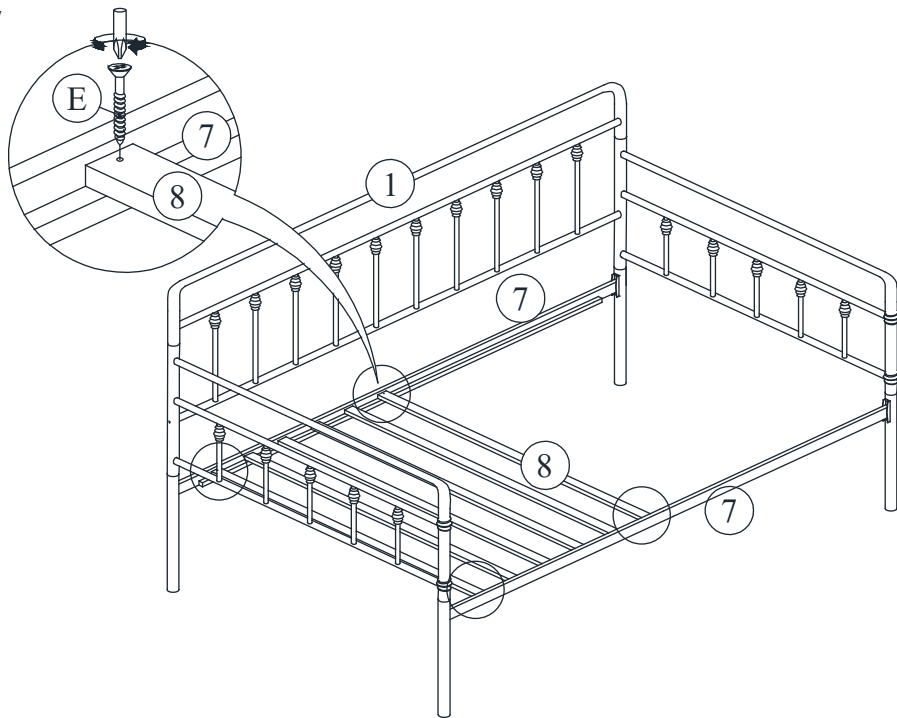

STEP 8

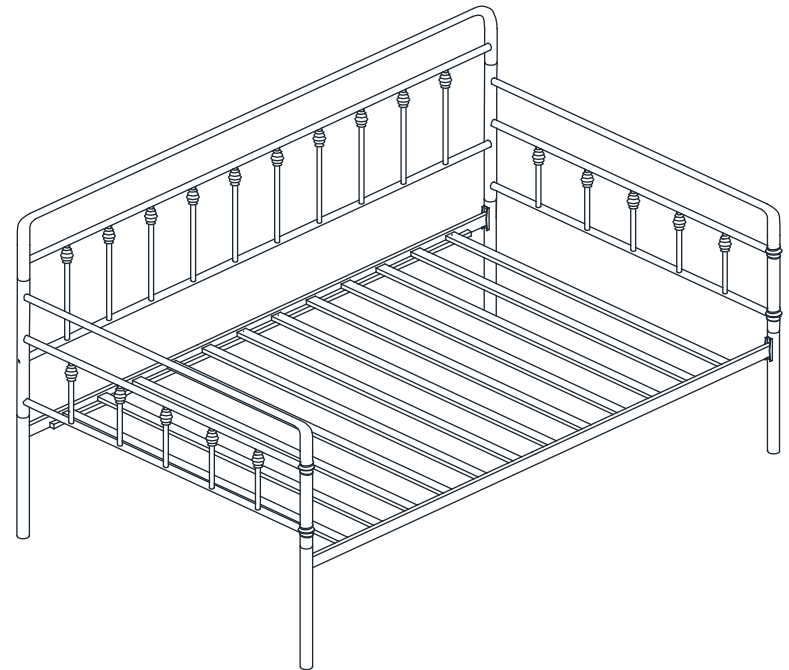

ASSEMBLY
COMPLETED

ASSEMBLY INSTRUCTION

STEP 9

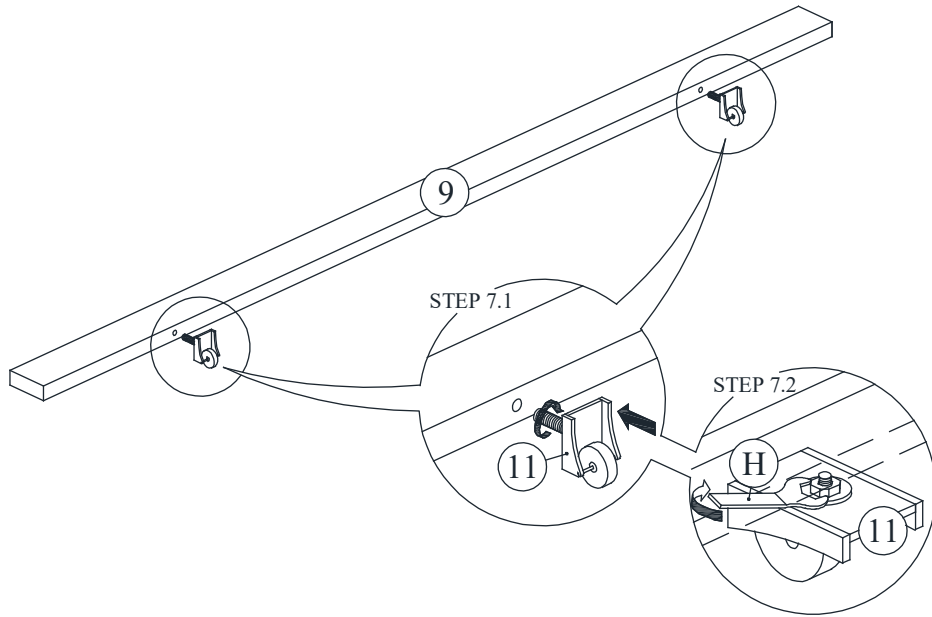

STEP 10

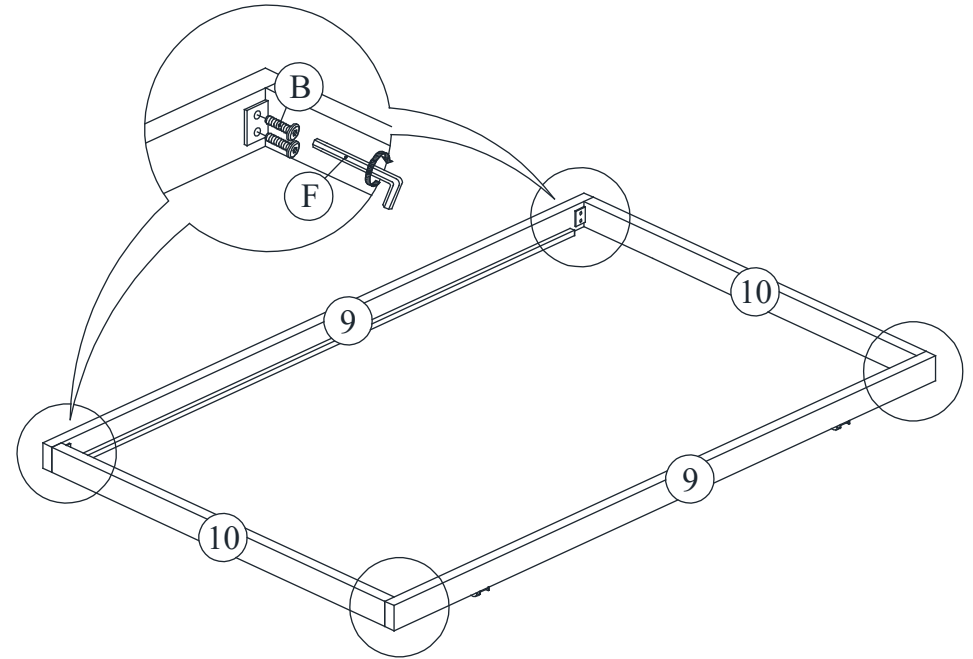

STEP 11

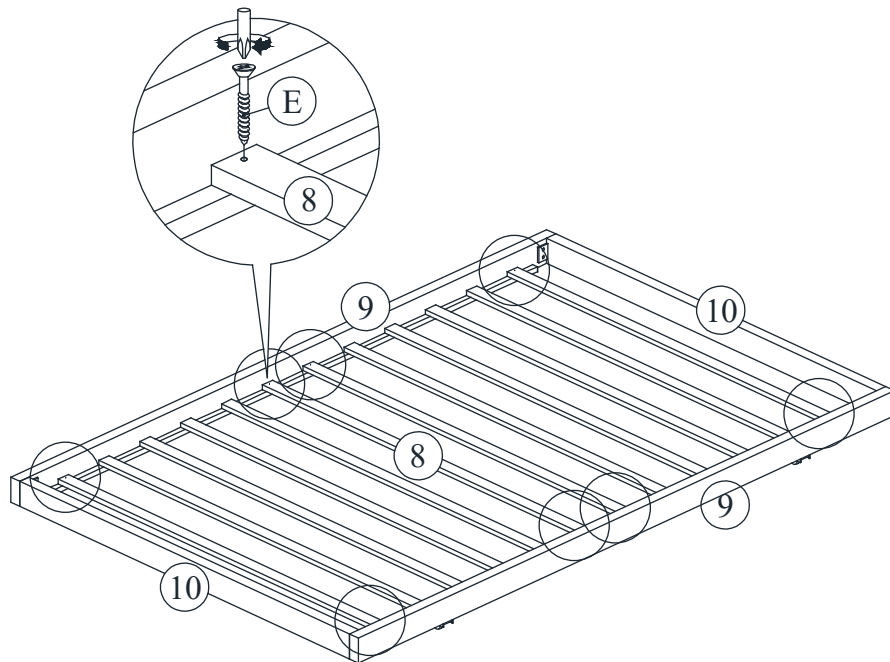

STEP 12

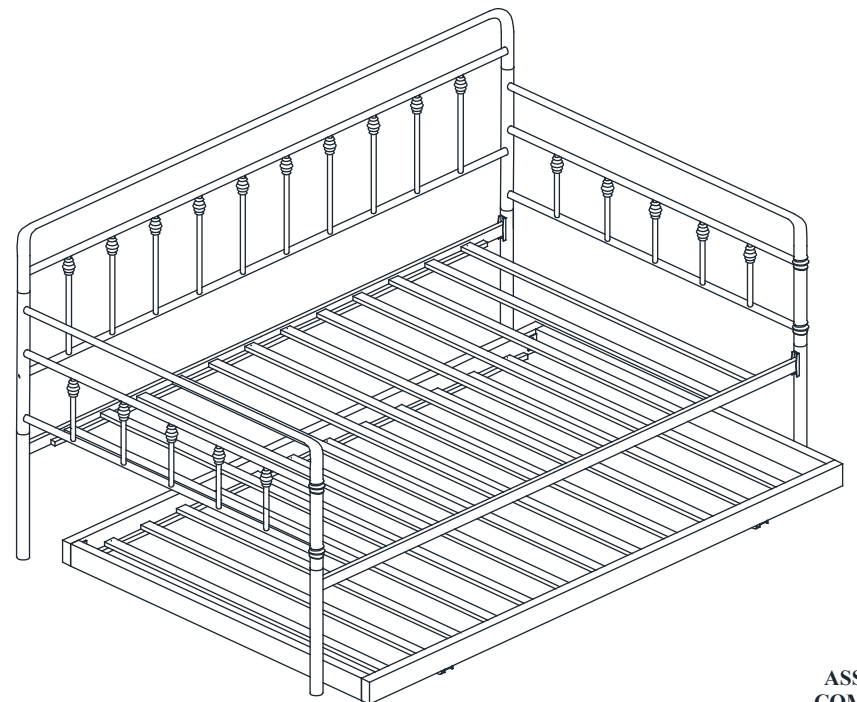

ASSEMBLY
COMPLETED