

We're here for you. Contact us at [support.us@soforoom.com](mailto:support.us@soforoom.com)



X 2

## Patio Dining Set

Model:TB102-US

NO.:YQ20251117

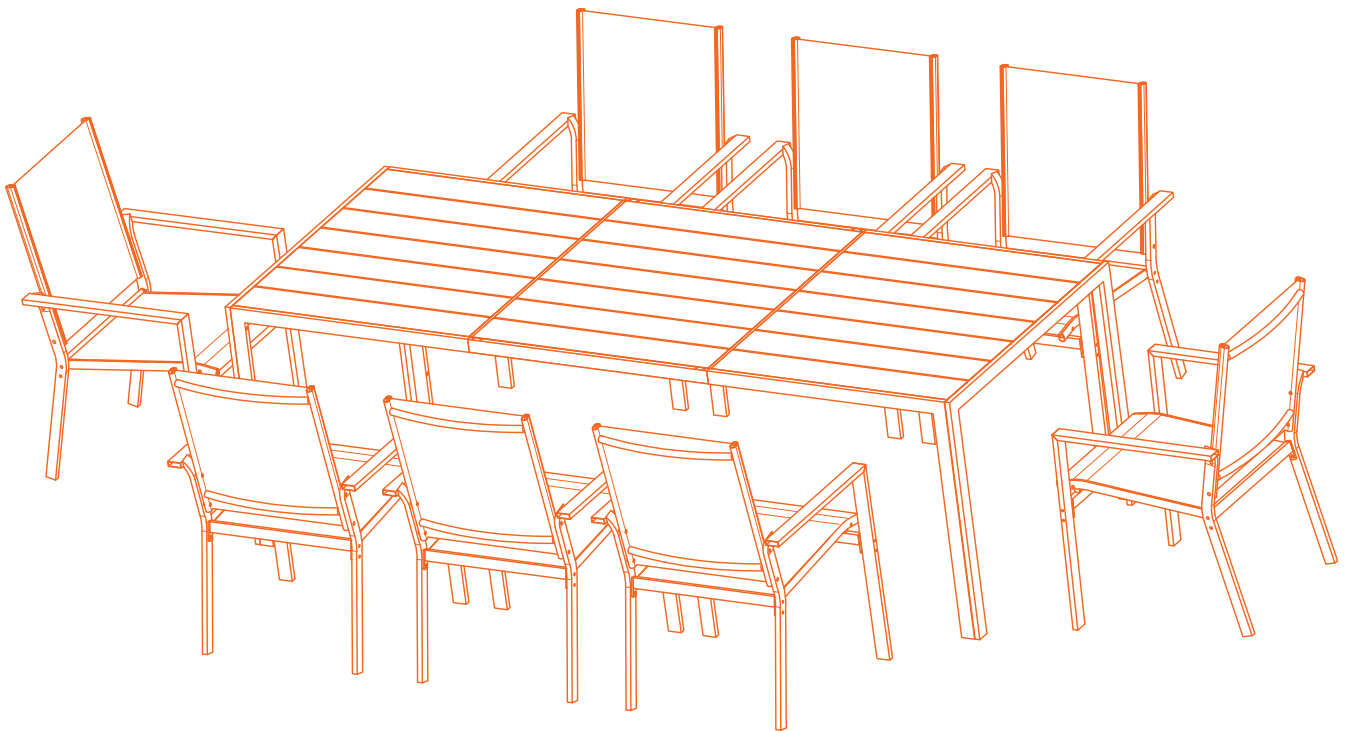

## HELP CENTER

Have questions about this product? Contact us, and we'll assist you!

● Customer Support Email:

[support.us@soforoom.com](mailto:support.us@soforoom.com)

\* Upon receiving your email, we'll respond within **48** working hours.

## CENTRO DE AYUDA

¿Tienes preguntas sobre tu producto? Ponte en contacto con nosotros y te ayudaremos.

- Correo electrónico de atención al cliente:

[support.us@soforoom.com](mailto:support.us@soforoom.com)

\*Al recibir tu correo electrónico, te responderemos en un plazo de **48** horas laborables.

# WHAT DO YOU GET ?

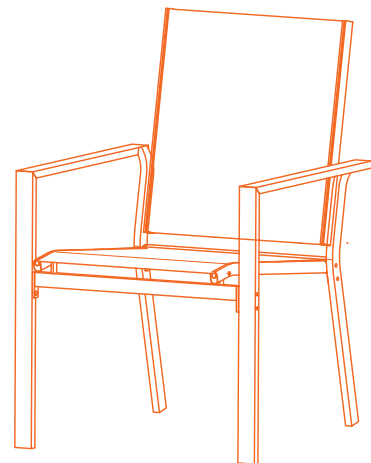
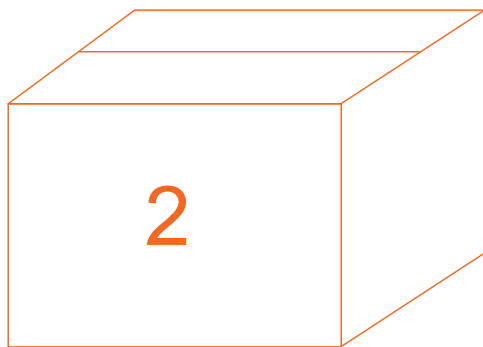
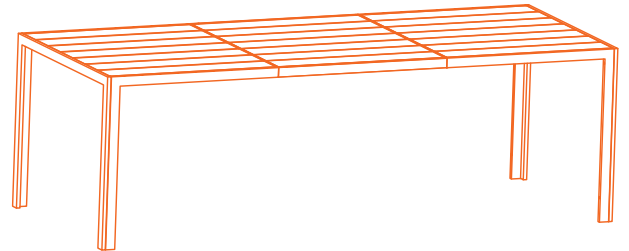
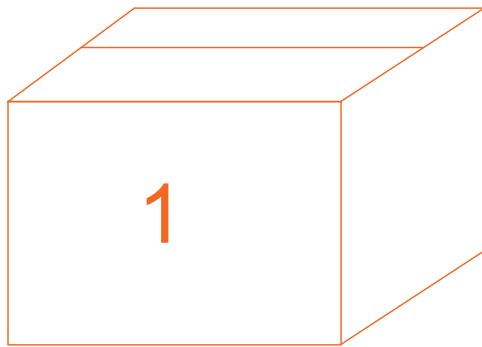

x 8

ATTENTION: THESE 2 BOXES MAY ARRIVE AT DIFFERENT TIMES,  
PLEASE WAIT PATIENTLY.

## FAQ

Q1: What should I do if the product I received is damaged or incorrect?

A1: If you've received a damaged, incorrect, or incomplete product, please reach out to our Customer Support Center at [support.us@soforoom.com](mailto:support.us@soforoom.com). Include your order number and photos.

Q2: What should I do if I encounter problems during installation?

A2: If you encounter any installation issues, please email to [support.us@soforoom.com](mailto:support.us@soforoom.com), attach a detailed description of the problem, we will provide you for professional technical support.

Q3: How do I apply a return?

A3: You can initiate a return within 30 days of purchase. Email us at [support.us@soforoom.com](mailto:support.us@soforoom.com) with your order number and the reason for return. We'll guide you through the process.

Note:

- Please contact us before returning the product to avoid any complications.
- Ensure the product is returned in its original packaging with all accessories included.

## PREGUNTAS FRECUENTES

P1: ¿Qué debo hacer si el producto que he recibido está dañado o es incorrecto?

R1: Si has recibido un producto dañado, incorrecto o incompleto, ponte en contacto con nuestro Centro de Atención al Cliente en [support.us@soforoom.com](mailto:support.us@soforoom.com). Incluye tu número de pedido y fotos que documenten el problema para que podamos ayudarte con la devolución o el cambio.

P2: ¿Qué debo hacer si encuentro problemas durante la instalación?

R2: Si tienes algún problema durante la instalación, por favor envía un correo electrónico a [support.us@soforoom.com](mailto:support.us@soforoom.com), adjuntando una descripción detallada del problema.

Te proporcionaremos soporte técnico profesional.

P3: ¿Cómo puedo solicitar una devolución?

R3: Puede iniciar una devolución en los 30 días siguientes a la compra. Envíenos un correo electrónico a [support.us@soforoom.com](mailto:support.us@soforoom.com) con su número de pedido y el motivo de la devolución.

Te guiaremos a través del proceso.

Nota:

- Póngase en contacto con nosotros antes de devolver el producto para evitar complicaciones.
- Asegúrate de devolver el producto en su embalaje original y con todos los accesorios incluidos.

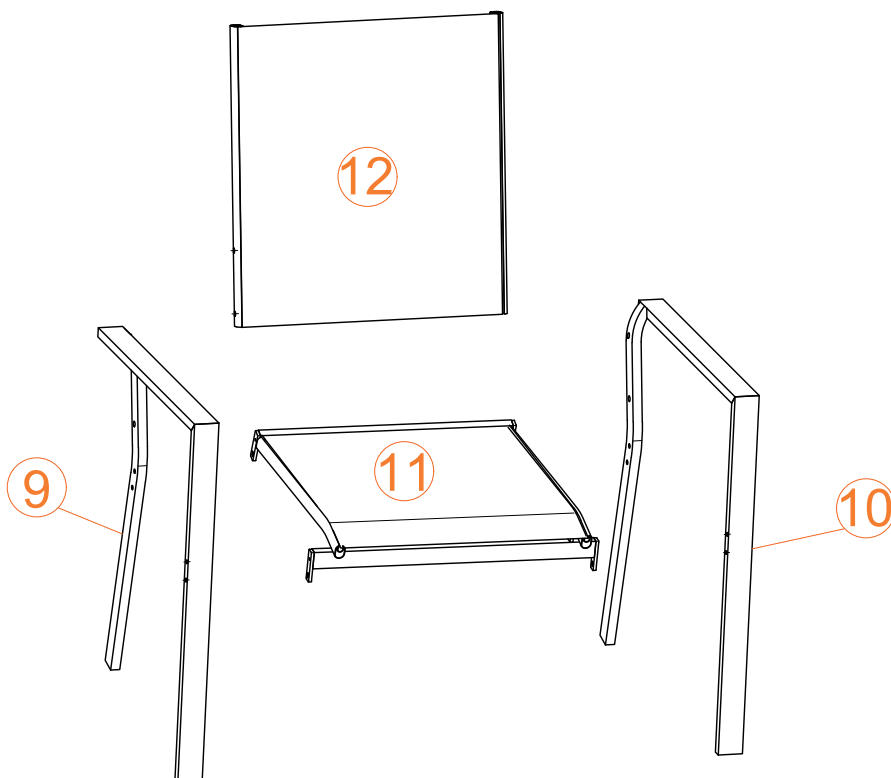
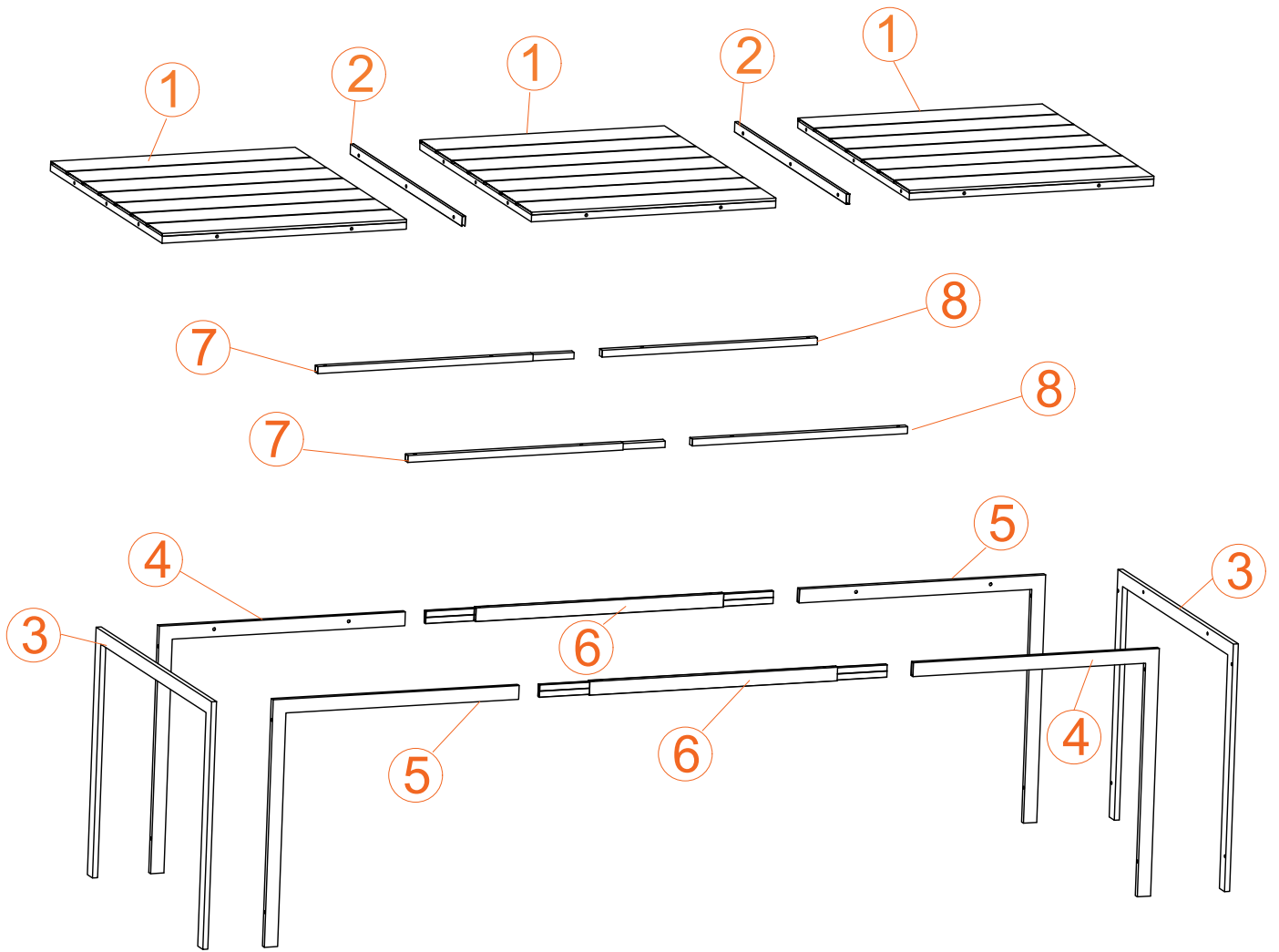

**x 8**

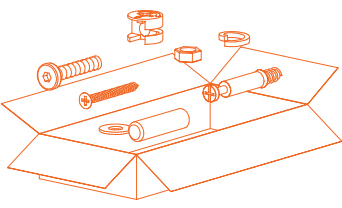

A x 1+1



M6

B x 1+1

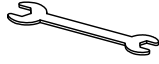

Wrench(M6-M8)

C x 8+1



Screw with washer  
M6\*15 mm

D x 16+2



Screw with washer  
M6\*25 mm

E x 72+5



Screw with washer  
M6\*30 mm

F x 46+3



Screw with washer  
M6\*50 mm

G x 38+3



M6

H x 4



I x 2

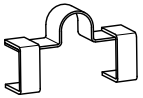

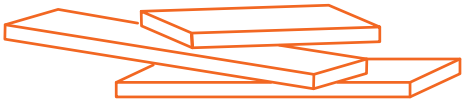

1 x 3

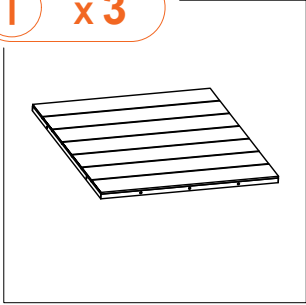

2 x 2

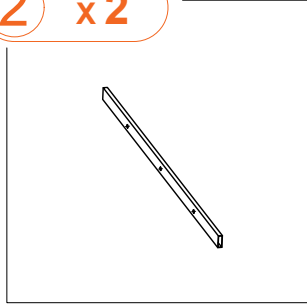

3 x 2

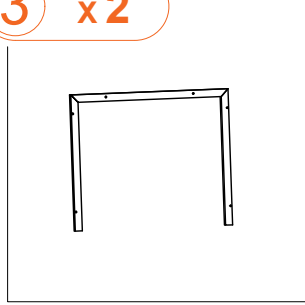

4 x 2

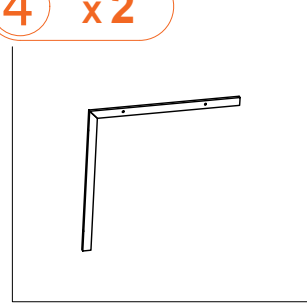

5 x 2

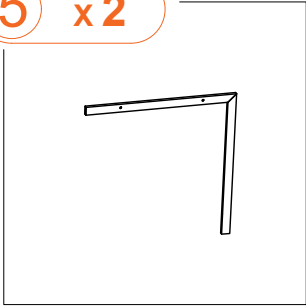

6 x 2

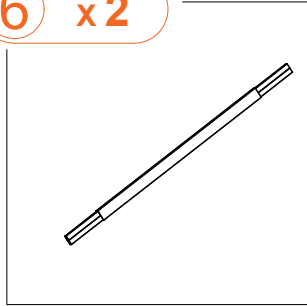

7 x 2

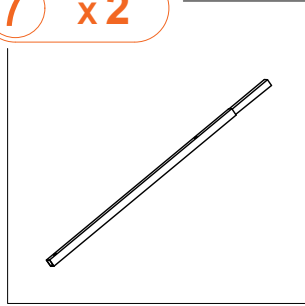

8 x 2

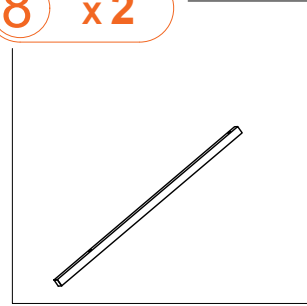

9 x 8

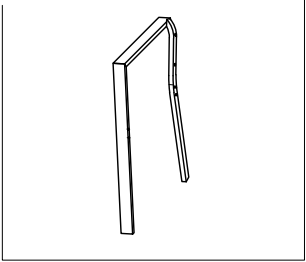

10 x 8

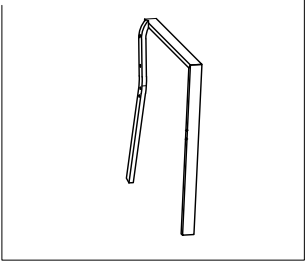

11 x 8

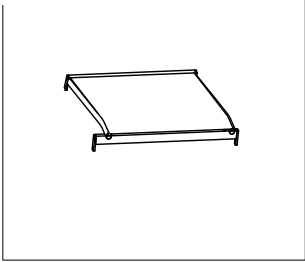

12 x 8

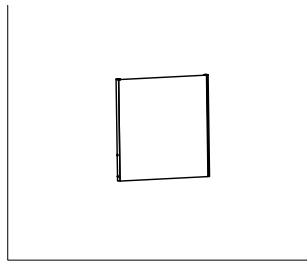

1

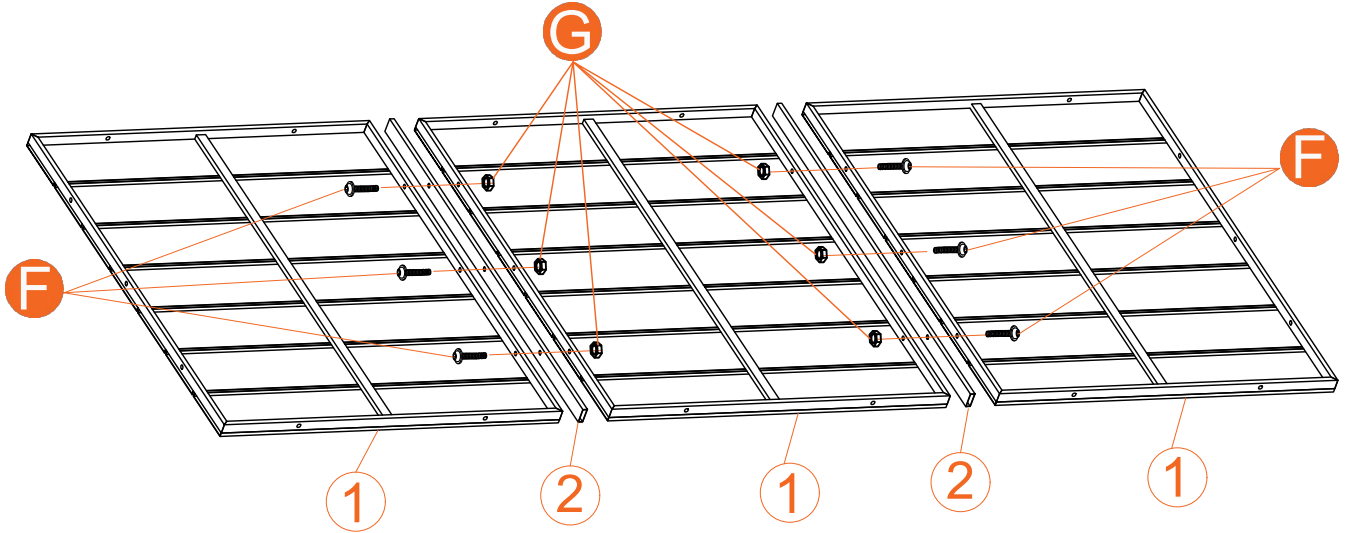
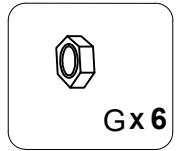
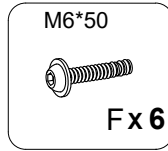
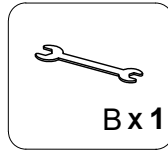
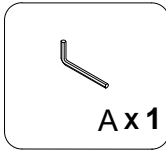
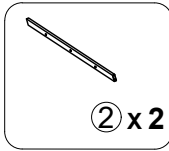
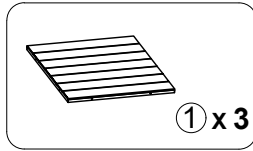

2

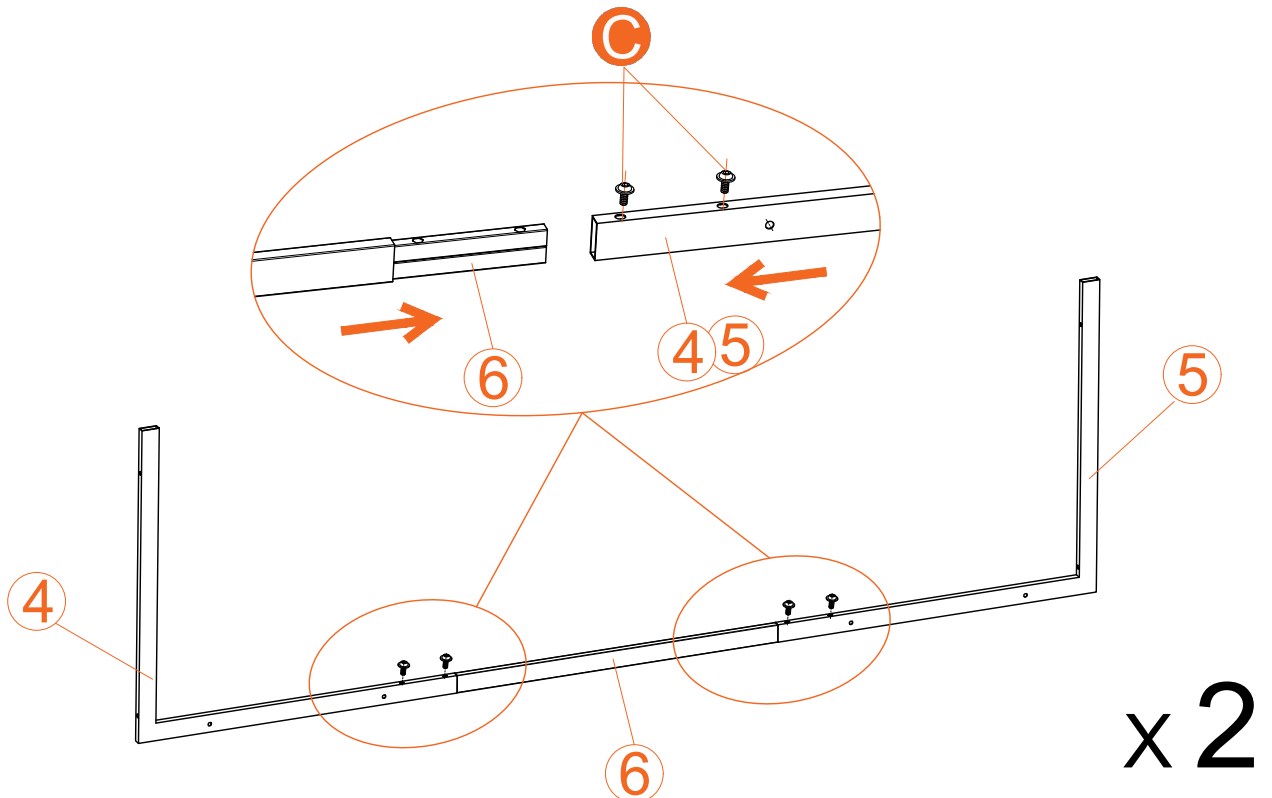
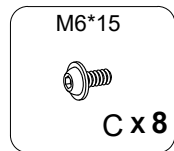
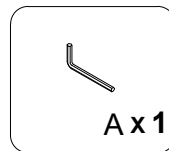
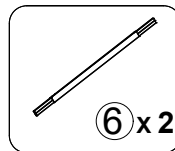
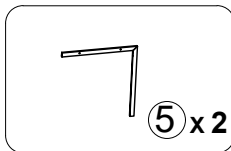
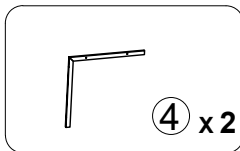



5

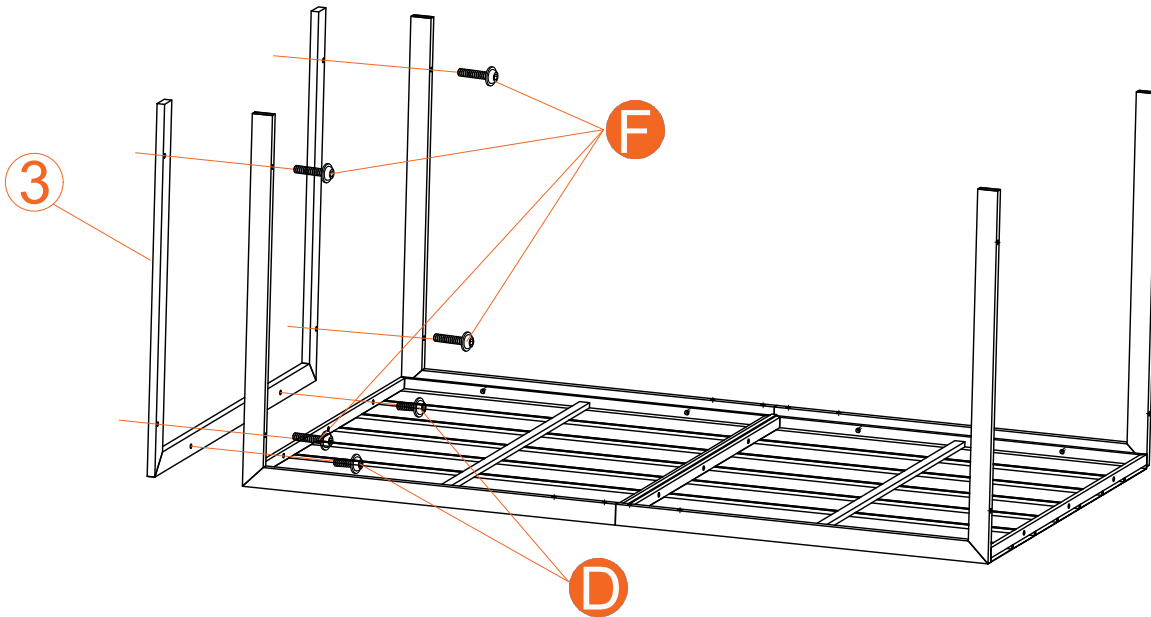
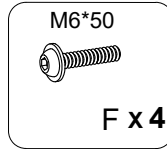
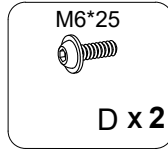
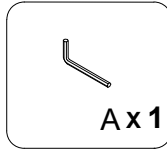
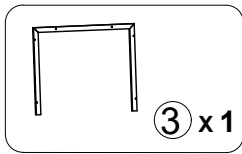

6

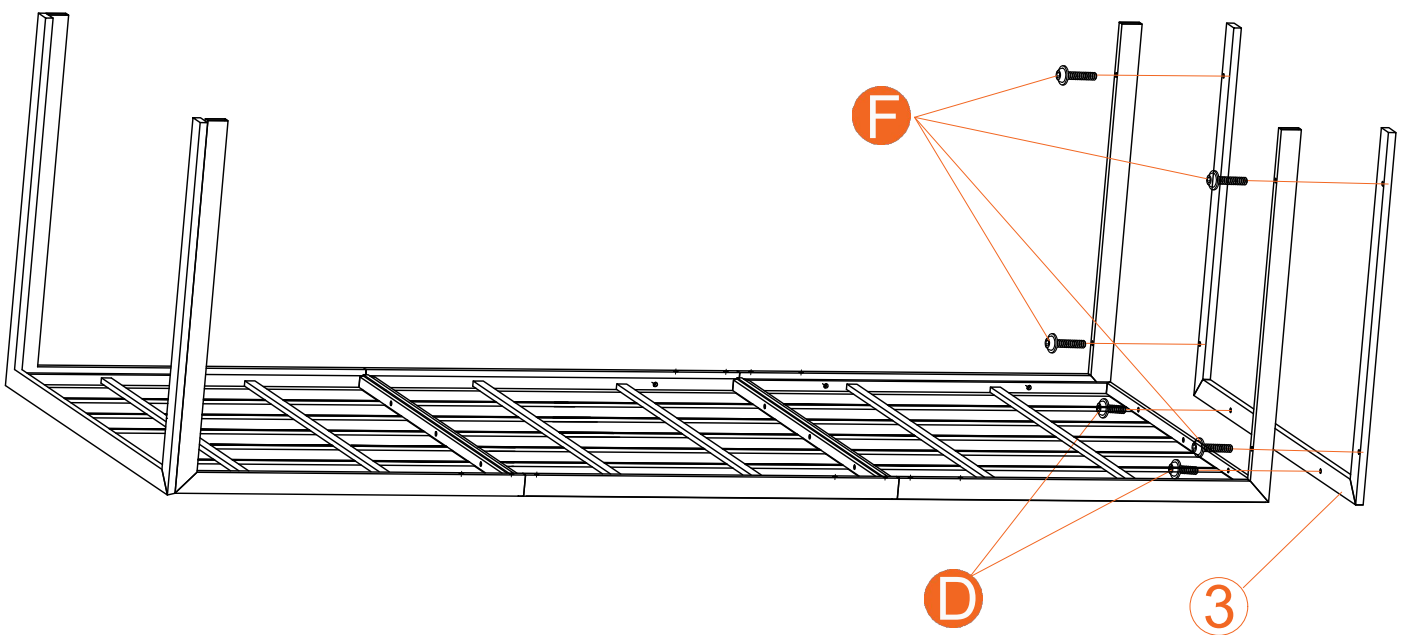
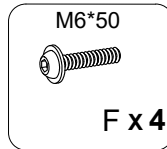
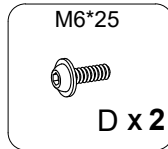
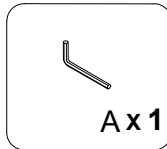
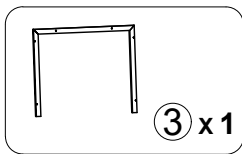

7

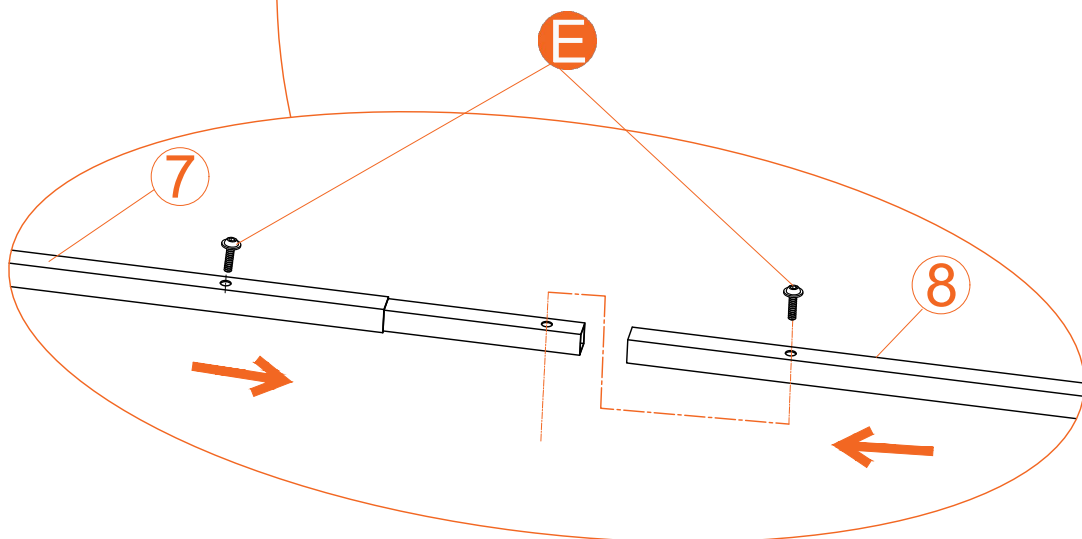
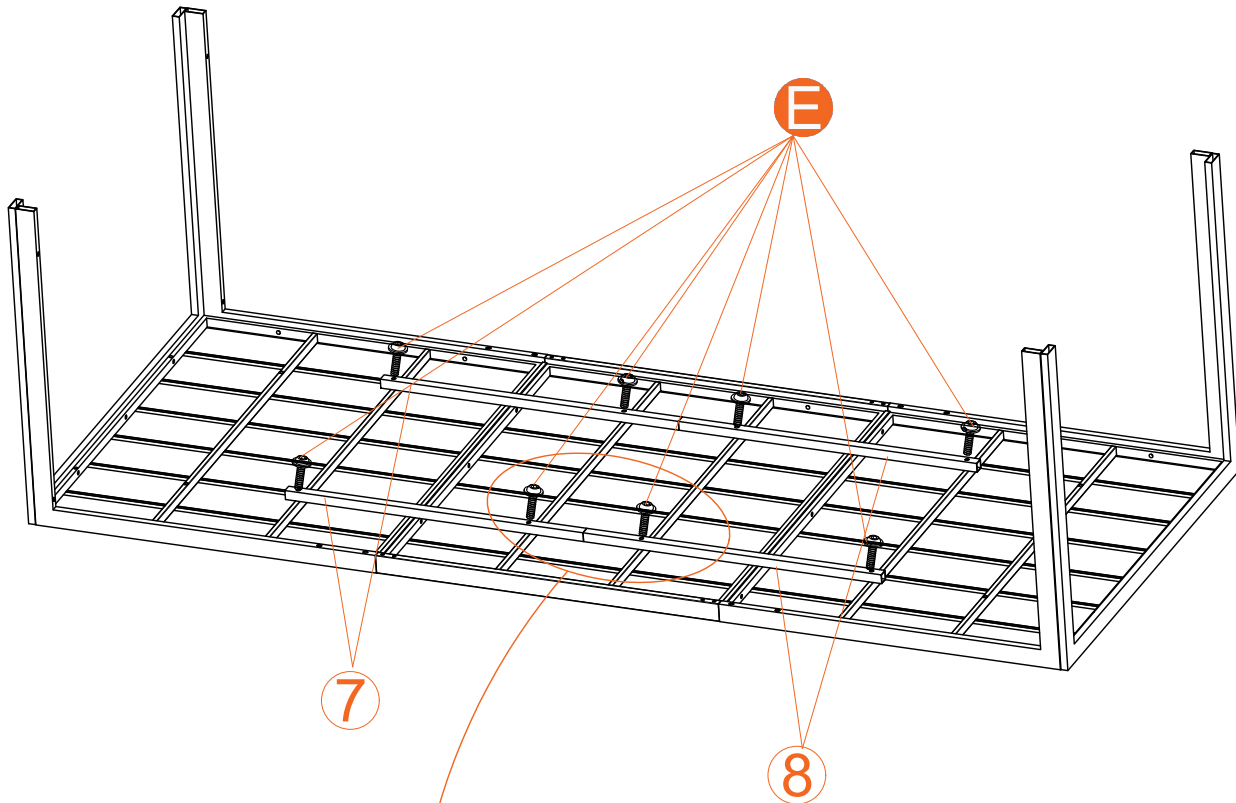
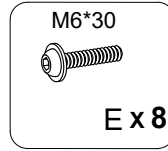
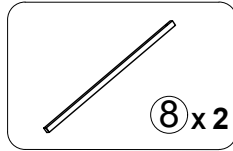
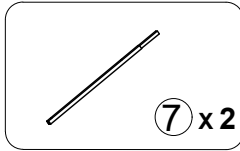

8

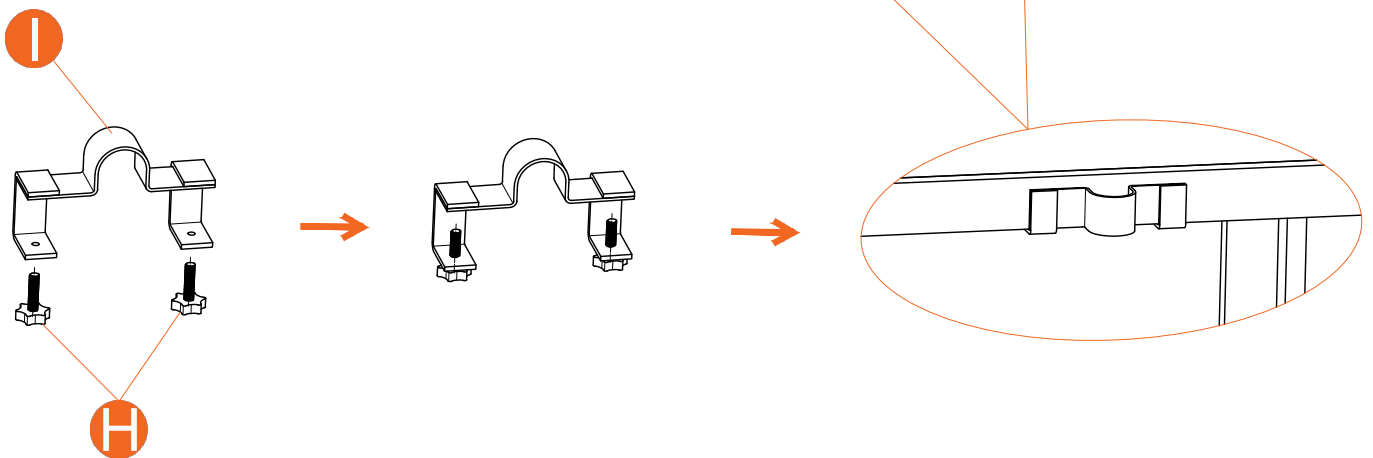
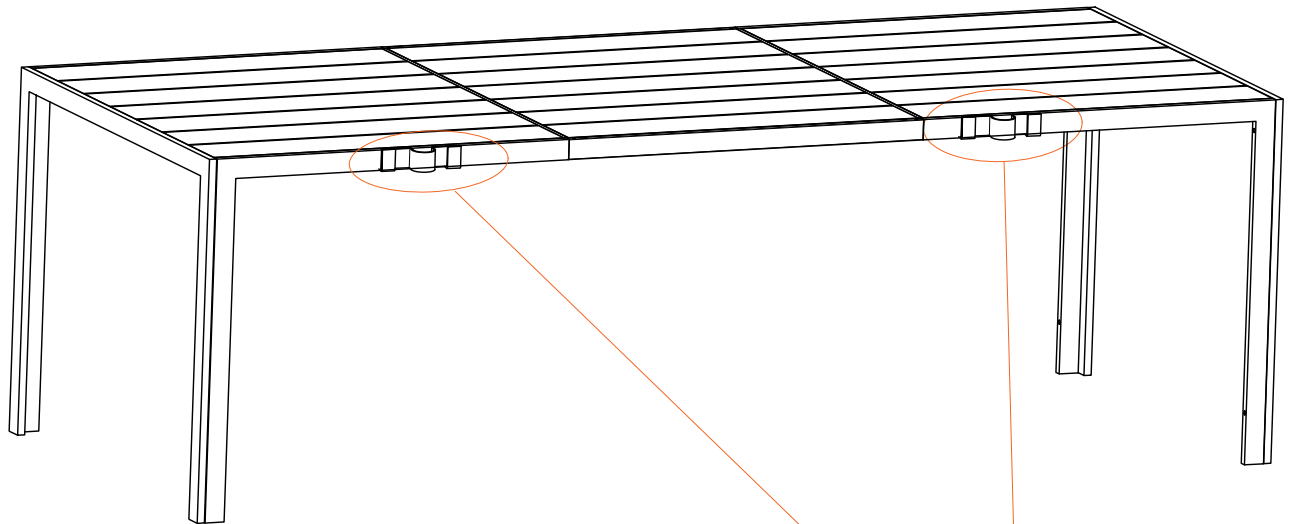
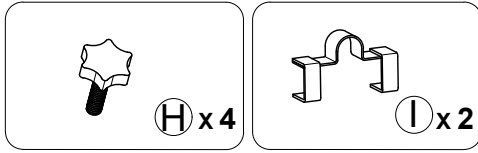

We offer a sunshade umbrella attachment that can be securely mounted on either side of a table to meet your needs.

9

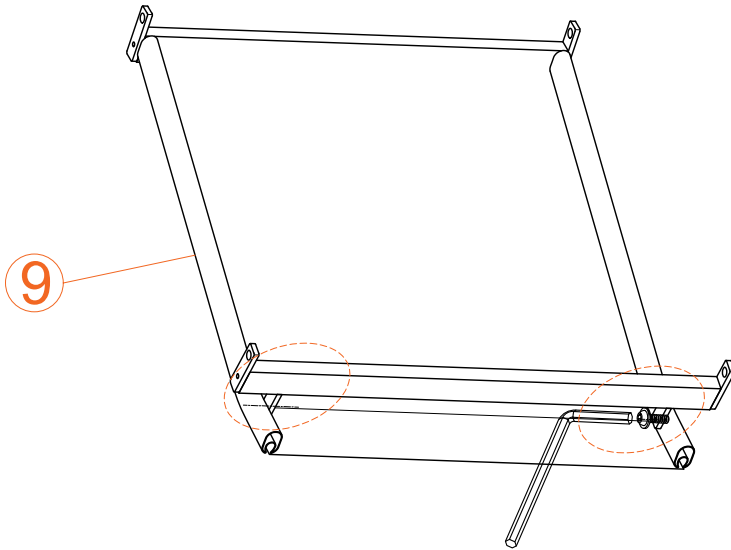
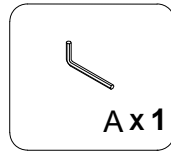
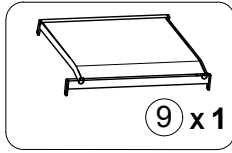

This part is pre-assembled and needs to be rescrewed during assembly

x 8

10

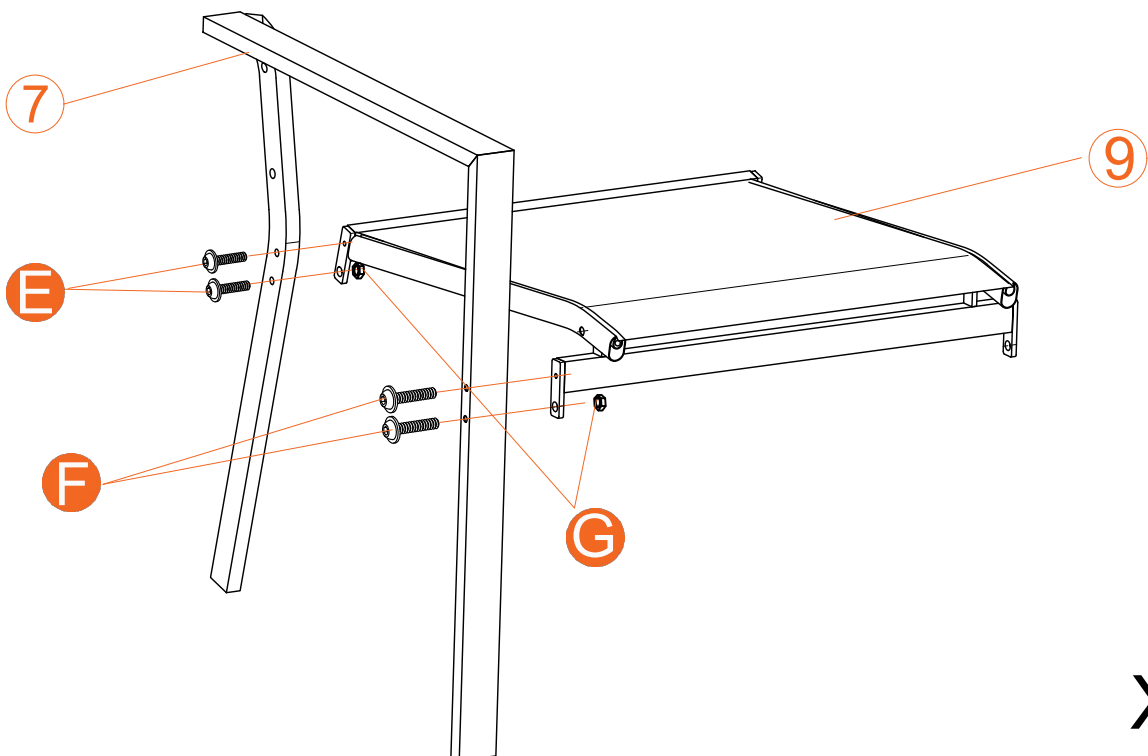
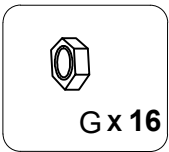
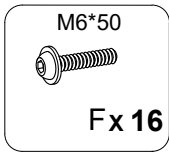
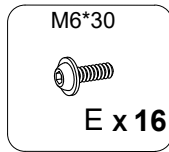
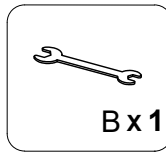
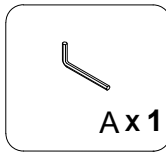
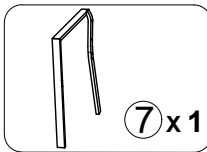

x 8

11

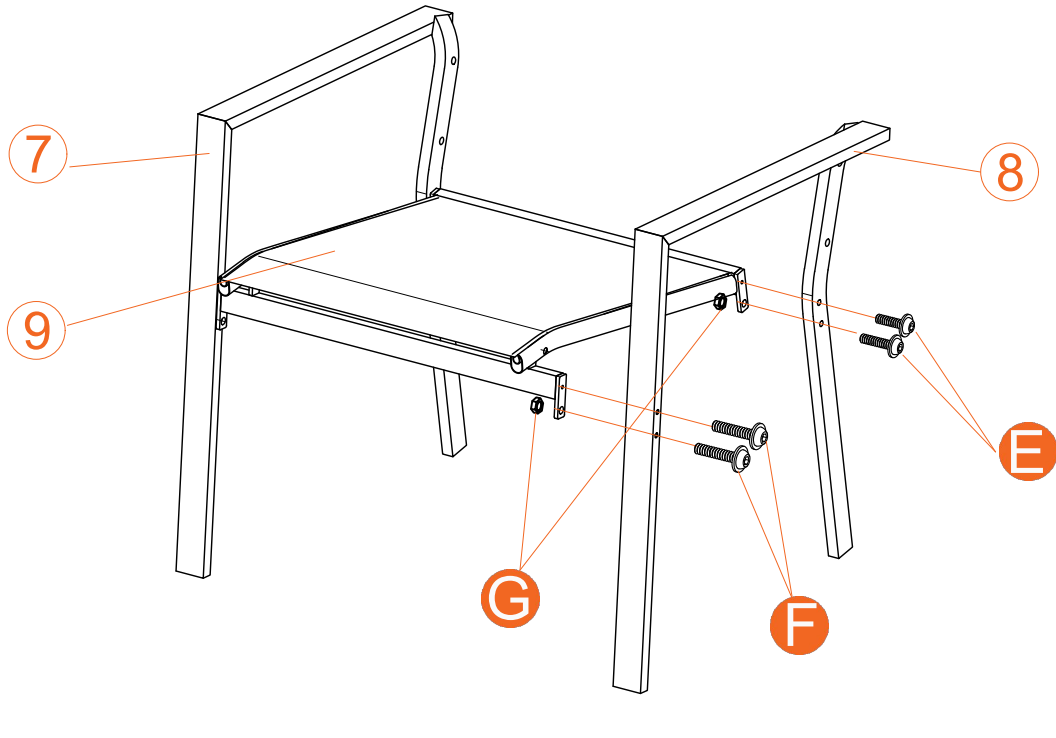
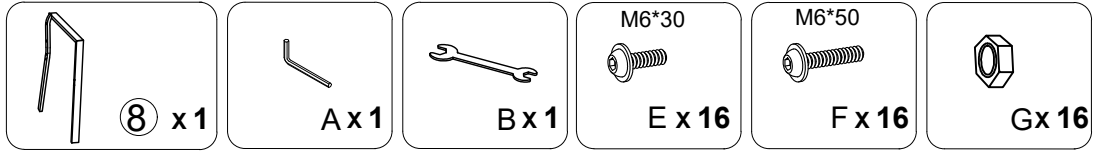

12

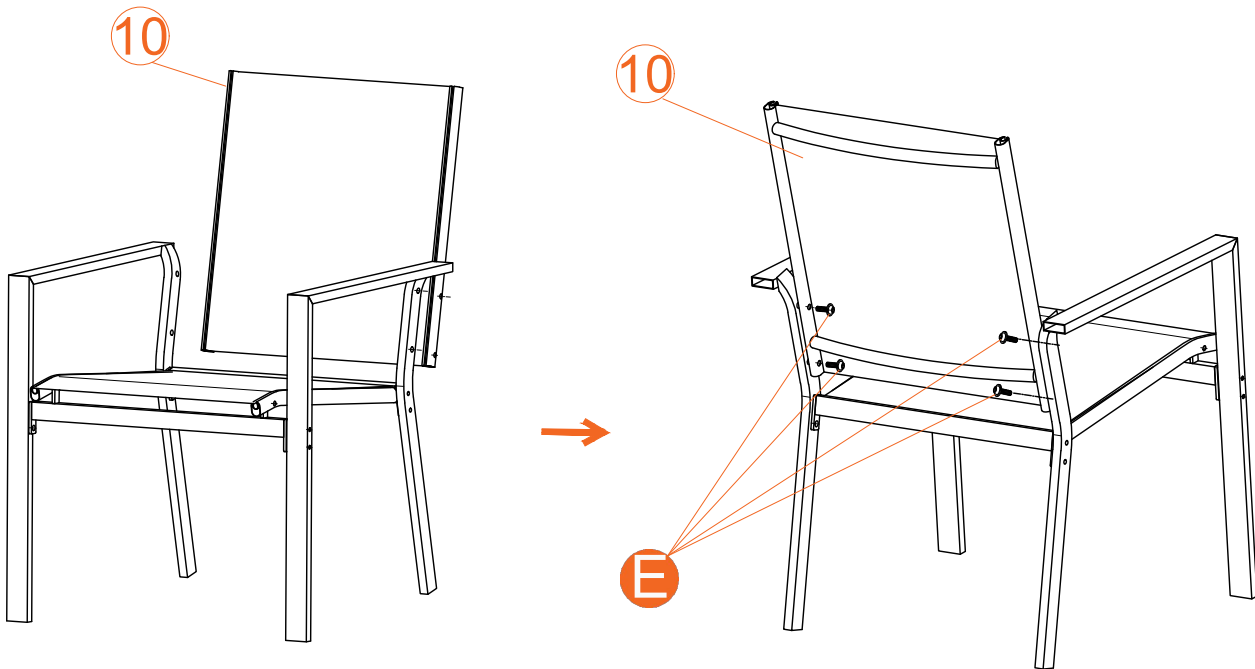
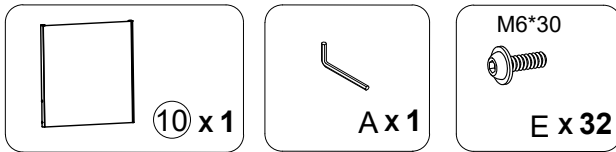

x 8

