

ASSEMBLY INSTRUCTIONS

WINDSOR MIXED MEDIA TABLE

ASSEMBLY
REQUIREMENTS

2-Person
Assembly

45 minutes
Assembly Time
(Approximate)

Thank you for purchasing our product!

Please refer and use this assembly instruction to assemble the product. Contact our customer service department in case there are any missing or damage parts or hardware. Replacement parts are normally shipped within 2 or 3 days.

PRODUCTS PURCHASED THROUGH OUR
AUTHORIZED VENDORS ONLY ARE ELIGIBLE
FOR REPLACEMENT PARTS.

We appreciate your business!

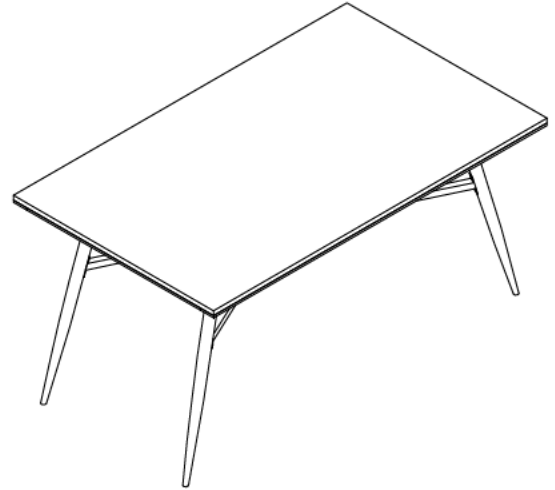

**THIS PRODUCT IS FOR INDOOR AND HOUSEHOLD USE ONLY -
NOT FOR COMMERCIAL USE.**

ASSEMBLY PREPARATION

1. Remove all packaging materials, staples and packing straps from the carton.
2. Refer to Parts List and Hardware List, and ensure parts and hardware are correct before assembly.
Contact customer service for missing parts.
3. Place all wooden parts on a clean, flat and soft surface (e.g. carpet or rug) to prevent scratch and damage to parts.

SAFETY PRECAUTION

1. KEEP ALL HARDWARE PARTS OUT OF REACH OF CHILDREN.
2. DISPOSE PLASTIC PACKAGING MATERIAL IMMEDIATELY TO AVOID ANY RISK OF SUFFOCATION TO CHILDREN AND ANIMALS.

TIPS FOR ASSEMBLY

1. Allow ample room for assembly and in close proximity to where product will be placed.
2. Assemble the product on a surface that does not scratch or damage the exterior gloss and finish of the furniture.
3. Identify all of the parts, hardware and quantities required for each step.
4. During assembly, do not over-tighten any fittings as this may cause damage.
5. DO NOT USE POWER TOOLS TO ASSEMBLE THIS PRODUCT.
6. Always place the product on a flat, level surface.
7. Do not sit or stand on the partially assembled product; only use the product for which it is intended.

CARE AND MAINTENANCE

- Use a slightly damp cloth to clean the product. Do not use bleach or abrasive cleaning material.
- Check all the fittings periodically and re-tighten as necessary. Do not use the product if any of the parts is damaged or broken.
- Never allow any kind of liquid to remain on your furniture. Absorption can cause wood to warp or delaminate.
- Do not place hot items (e.g. hot drinks) directly onto the wood surface.
- Do not drag and/or pull the furniture.

ASSEMBLY INSTRUCTIONS

WINDSOR MIXED MEDIA TABLE ITEM# 19017 BLK/ESP

STEP 1

Use Bolt (1) to fasten each Leg (B) to Stretcher (C) as shown. Use Allen Key (2) to loosely tighten the bolt.

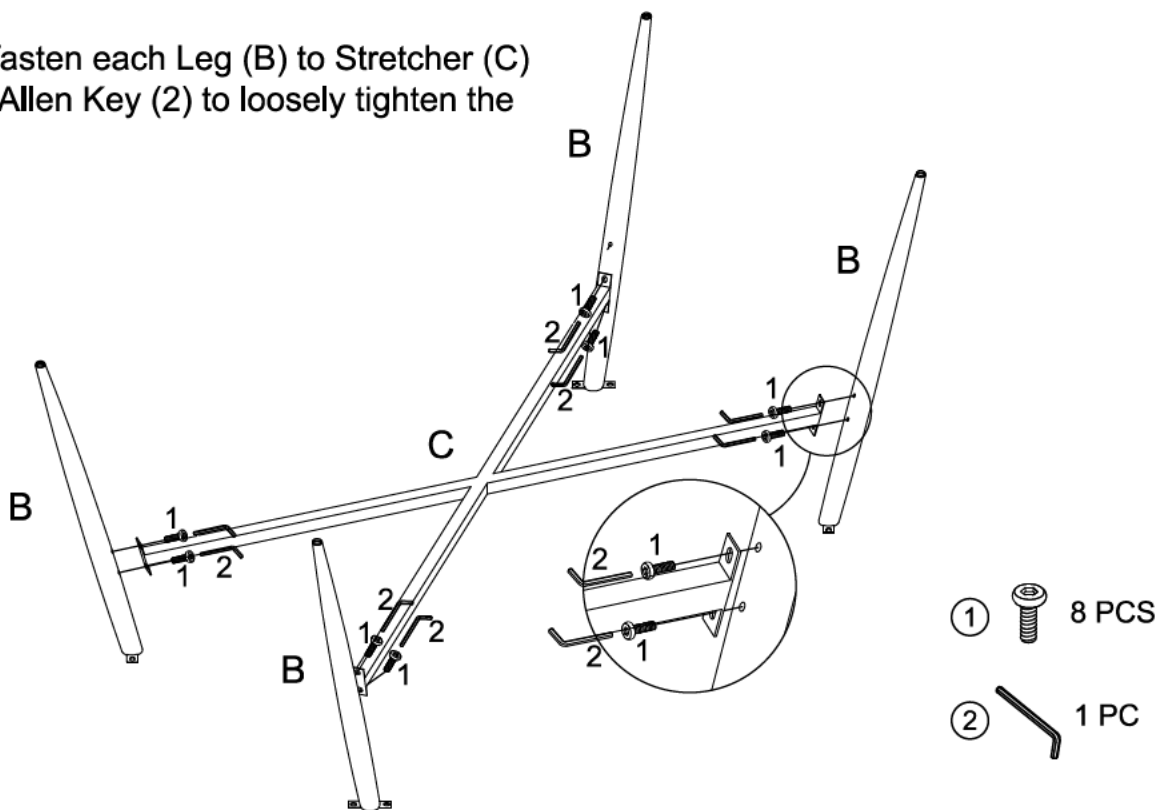

STEP 2

- With assistance, place Table Top (A) bottom-side up on a flat surface & soft material to prevent scratch and damage.
- Align bolt holes on bracket end of Leg to bolt holes on bottom-side of (A) and use Bolt (1) to fasten Leg to Table Top. Do not tighten (1) completely until all the bolts are in place.
- Tighten all of the Bolts (1) from STEP 1.

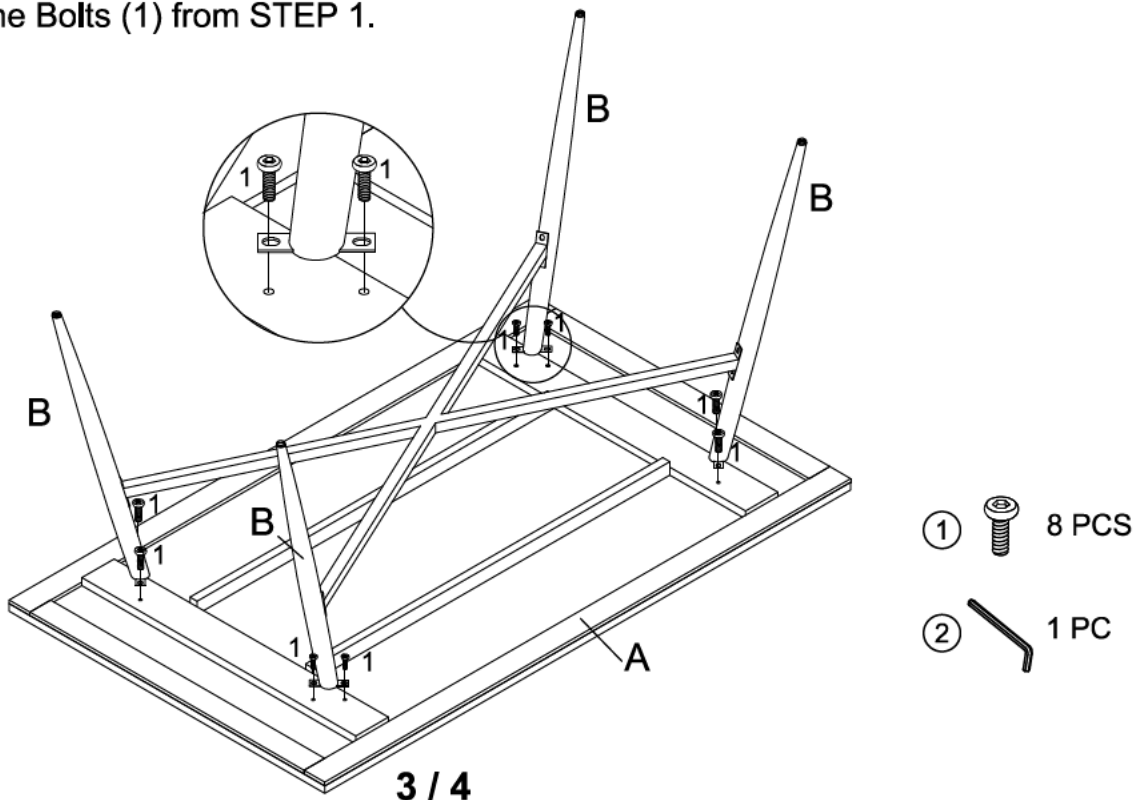

ASSEMBLY INSTRUCTIONS
WINDSOR MIXED MEDIA TABLE ITEM# 19017 BLK/ESP

STEP 3

With assistance, set the table right-side up.
If necessary, use Adjustable Leveler on the bottom of each leg to level the table.

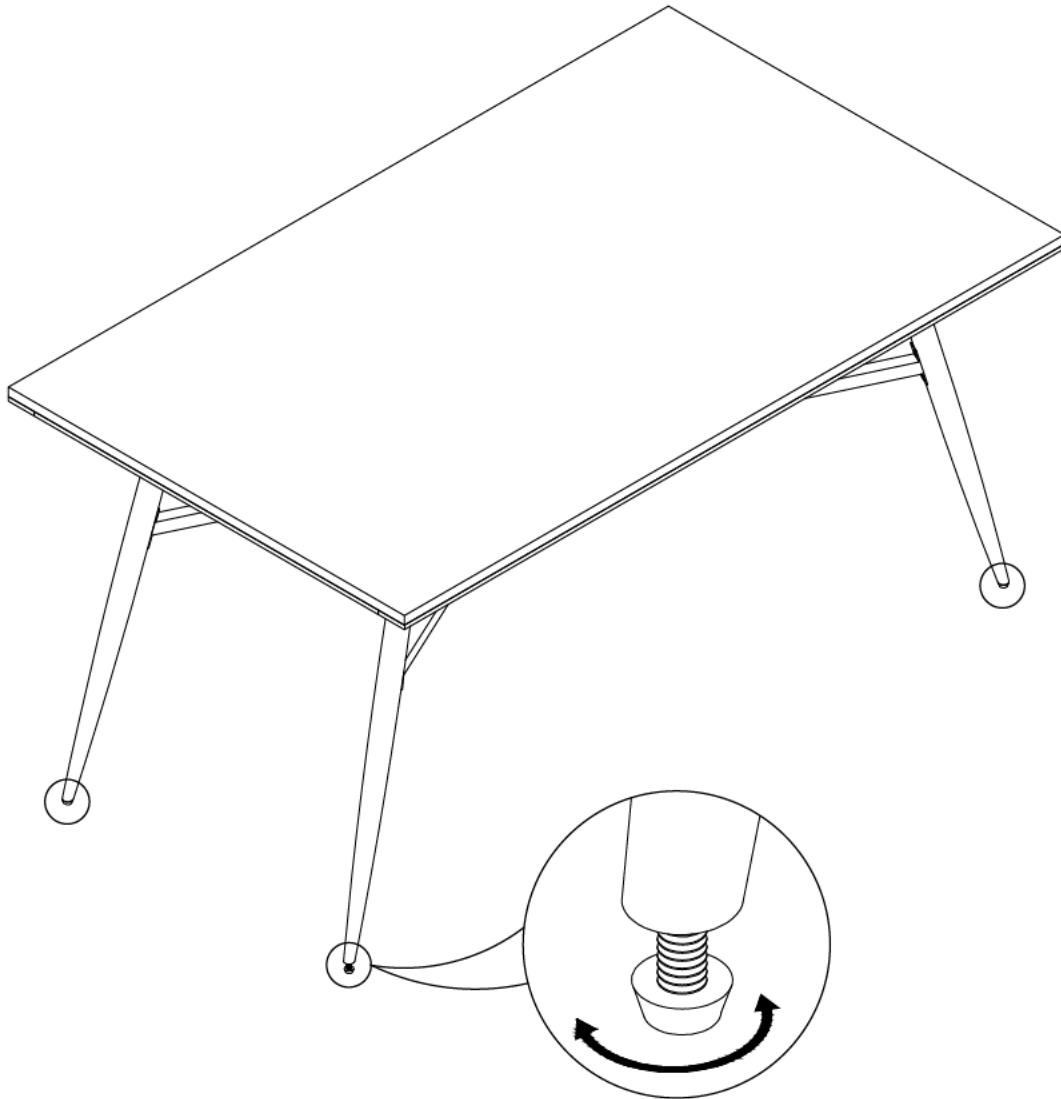

The assembly of the table is complete.