

About the Wood and Finish

This product has been carefully crafted of: MDF, solid pine wood and/or pine veneers. These materials derive from plantations, a renewable and well managed forest, therefore, not endangering the environment. The highest quality standards have been implemented to assure a sturdy and reliable product. Due to the natural variances in the graining of wood, you may notice subtle differences in the shading and tone of the color stain, warp, holes, wood knots and also small cracks. This is not a defect. But rather a result of the natural beauty of the wood itself.

**Care and
maintenance:**
Dust when needed using
a smooth, dry cloth.
Household furniture
polish can be used
occasionally to restore luster.

ASSEMBLY INSTRUCTIONS

TWIN LOFT BED

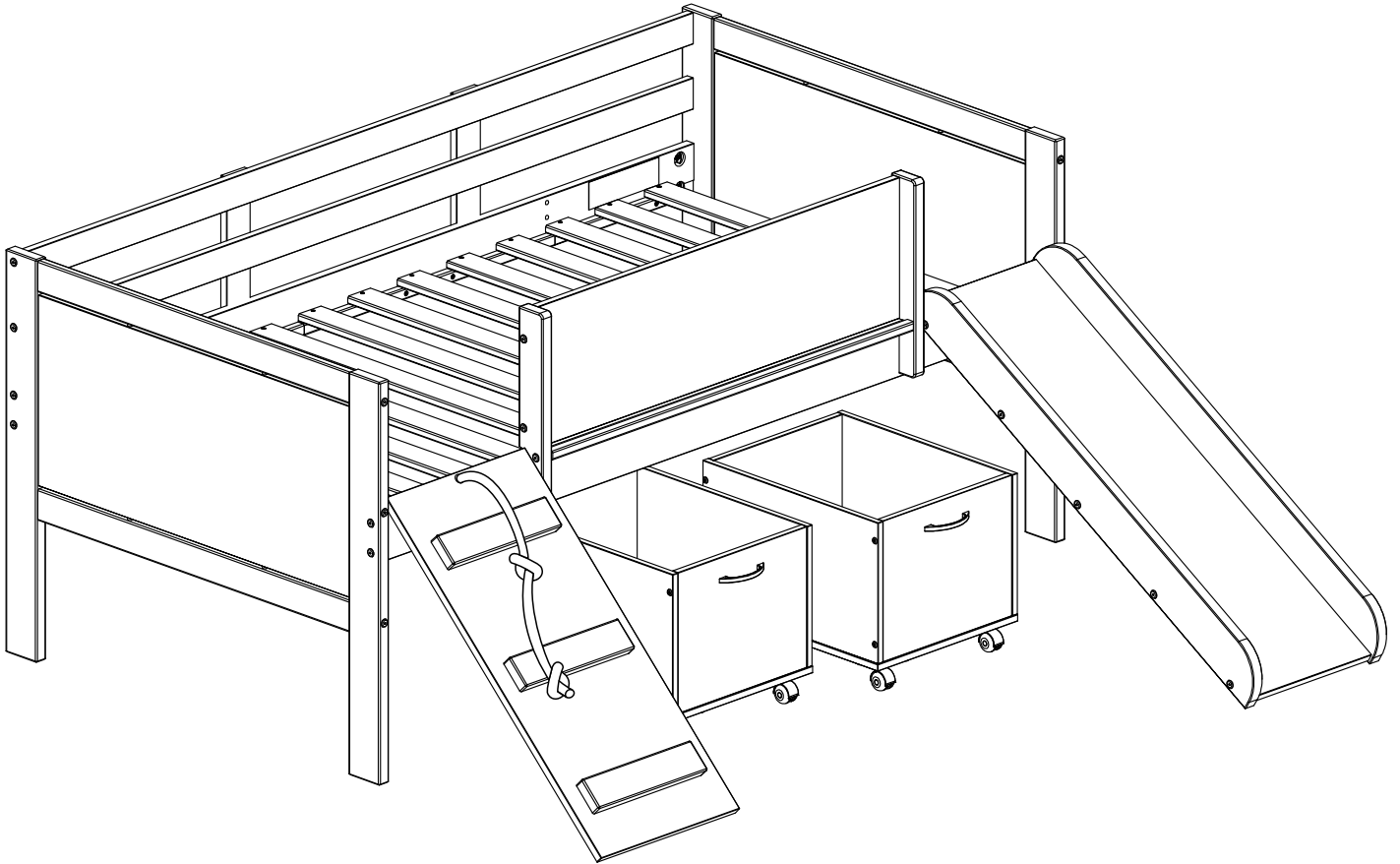

Thank you for purchasing this quality product. Be sure to check all packing material carefully for small parts which may have come loose inside the carton during shipment. Separate identify and count all parts and hardware.

Compare with the parts list to be sure all parts are present.

"DO NOT TIGHTEN SCREWS UNTIL COMPLETELY ASSEMBLED"

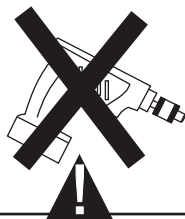

* Use of power tool to assemble this product will invalidate any claim and damage this product making unsafe !!!
* Please assemble on a clean soft surface to avoid damage.

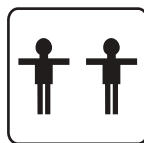

+

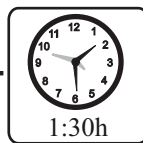

Tools Required



(Not included)

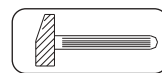

(Not included)

IMPORTANT:

PLEASE READ INSTRUCTION BEFORE STARTING THE ASSEMBLY

Part list: - Twin Loft Bed



MANUFACTURER LABEL

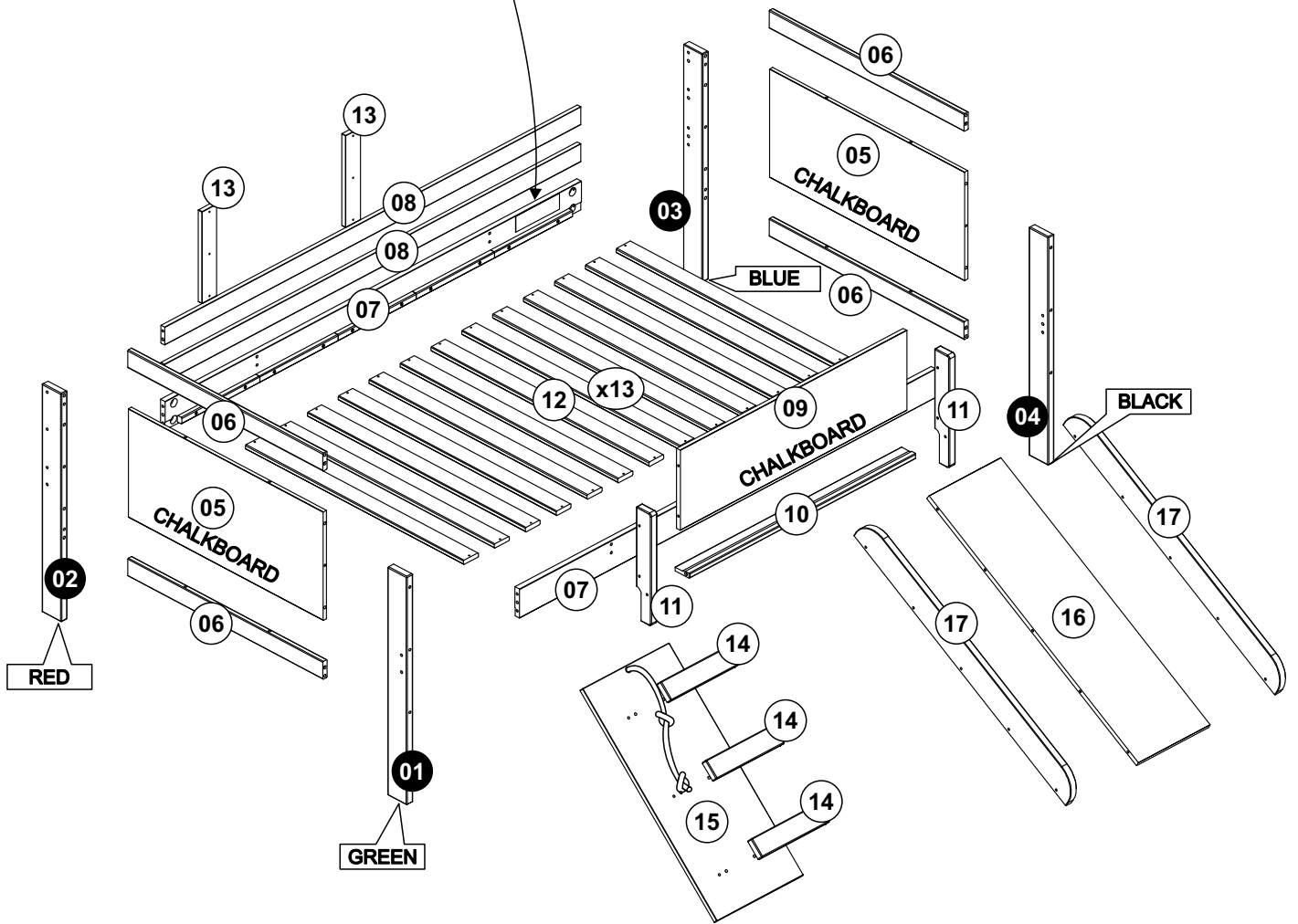

Identifying the Hardware-Identify the hardware using the illustrations below.

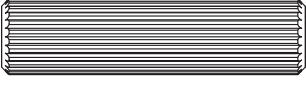
A  Qty **16**
1 1/16" Wooden Dowel (10 x 40mm)

B  Qty **14**
1 9/16" Wooden Dowel (8 x 40mm)

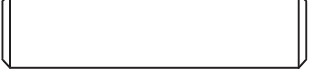
C  Qty **08**
1 9/16" Black connection (10 x 40mm)

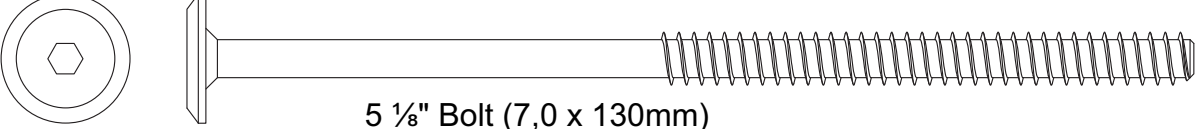
D  Qty **12**
5 1/8" Bolt (7,0 x 130mm)

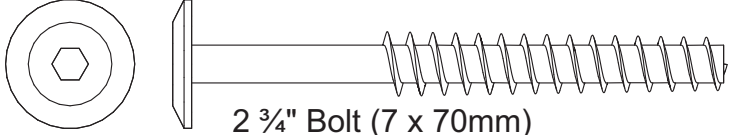
E  Qty **20**
2 3/4" Bolt (7 x 70mm)

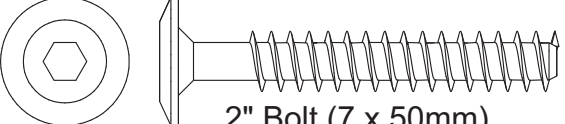
F  Qty **04**
2" Bolt (7 x 50mm)

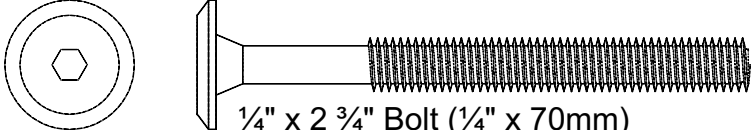
G  Qty **08**
1/4" x 2 3/4" Bolt (1/4" x 70mm)

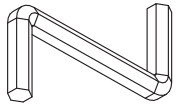
H  Qty **01**
Allen wrench 4mm

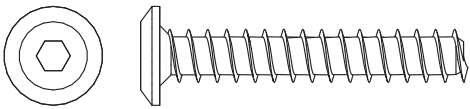
I  Qty **06**
1 9/16" Bolt (7 x 40)

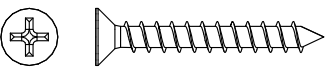
J  Qty **32**
1 3/16" Screw (4 x 30mm)

K  Qty **08**
1/4" Elliptical Nut

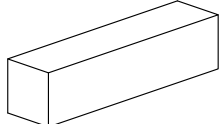
L  Qty **02**
Wooden spacer 2 15/16" (75mm)

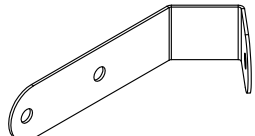
M  Qty **04**

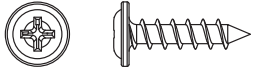
N  Qty **12**
5/8" Screw (4 x 16mm)

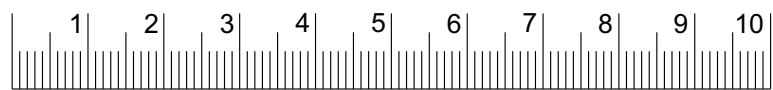

*Actual size of screws and bolts, for measurements checking.

01 Black Connection

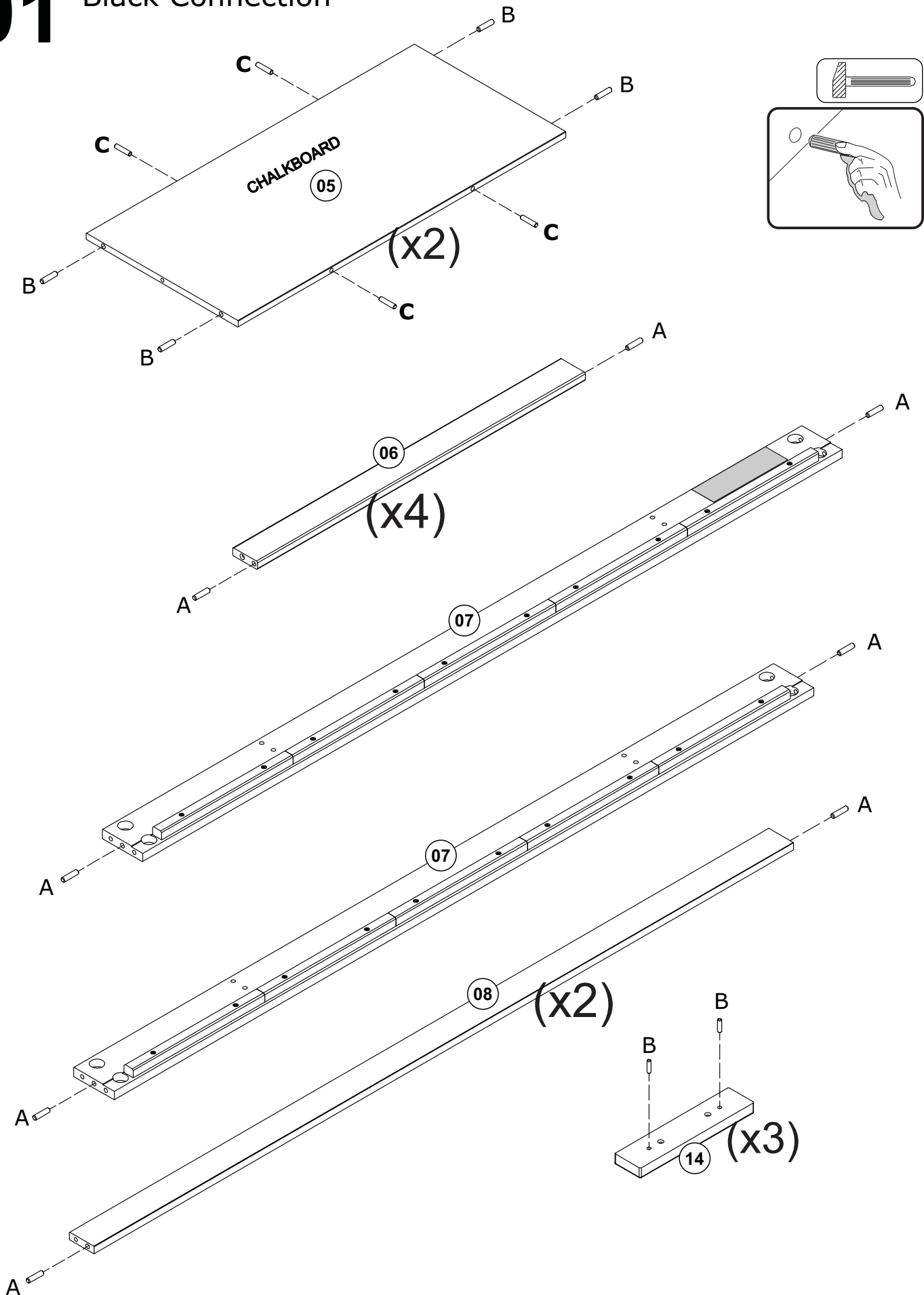

A  Qty **16**
1 9/16" Wooden Dowel

B  Qty **14**
1 9/16" Wooden Dowel

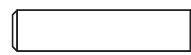
C  Qty **08**
1 9/16" Black connection

02

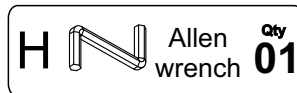
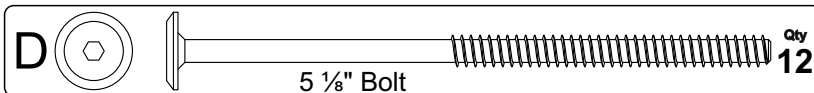
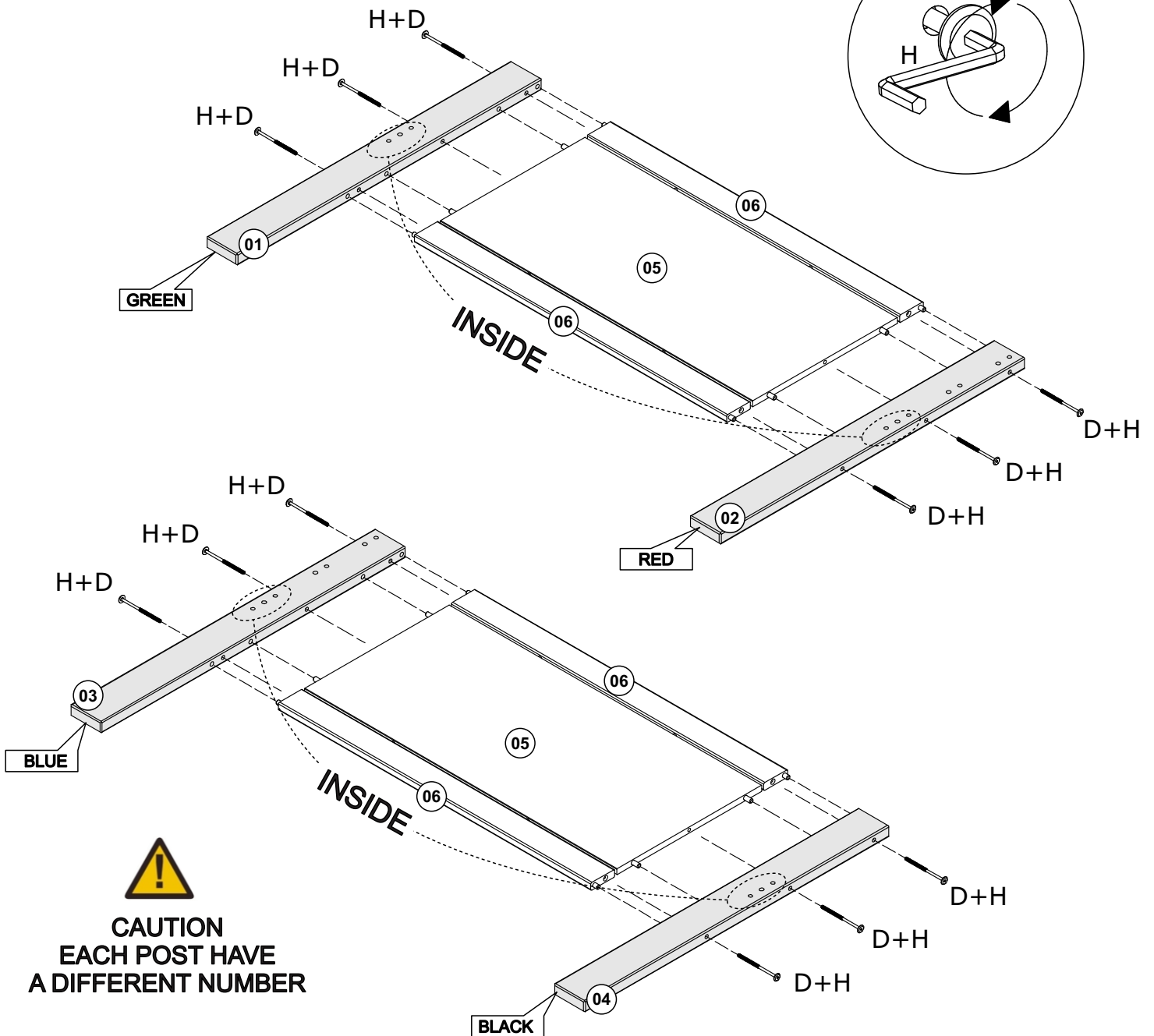
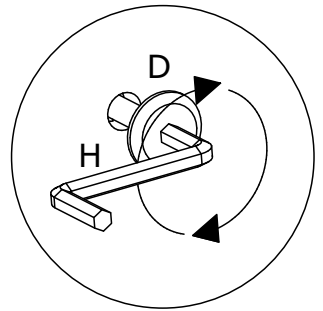
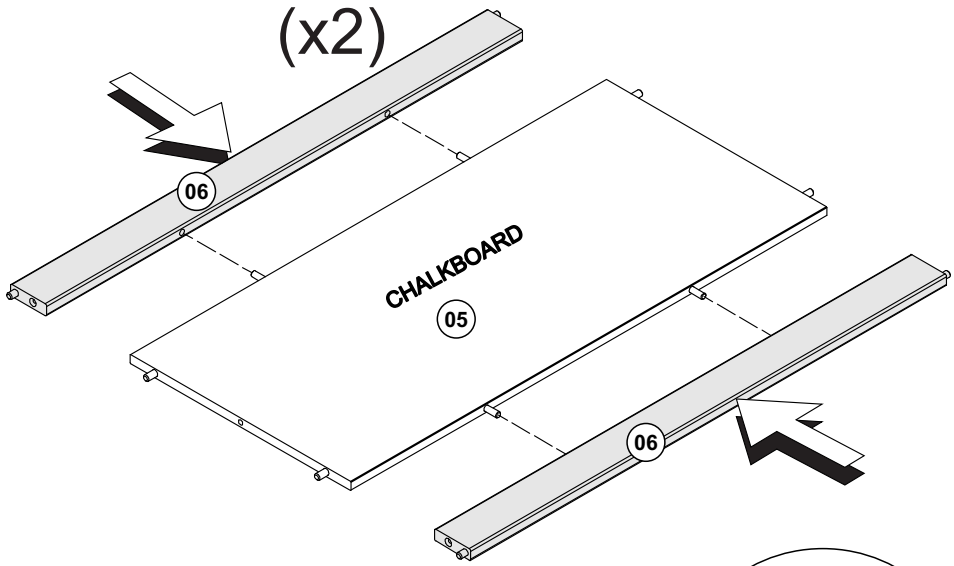

03

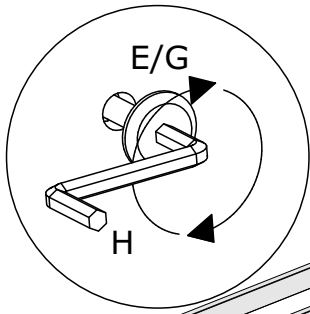

H+E
H+E
H+G
H+G

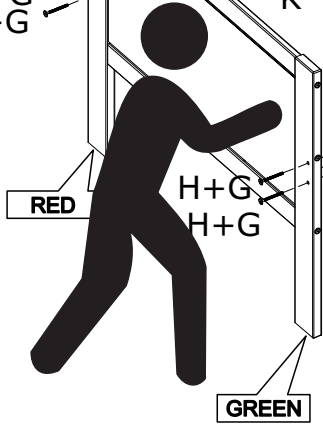

08

08

07

BLUE

BLACK

E+H
E+H

G+H
G+H

G+H
G+H

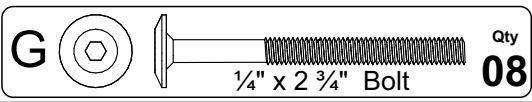
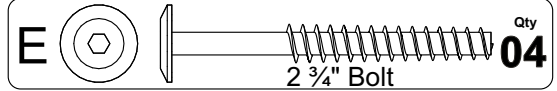

04



Attention Detail

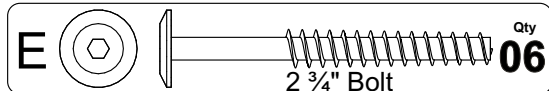
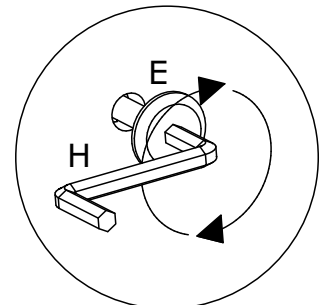
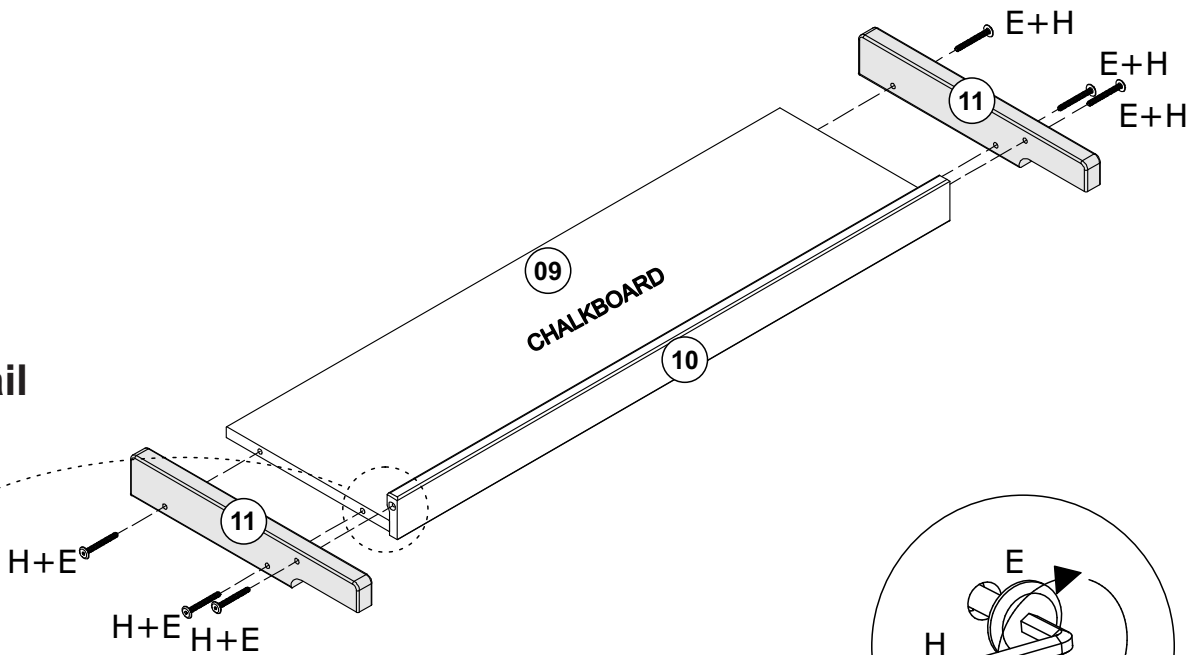
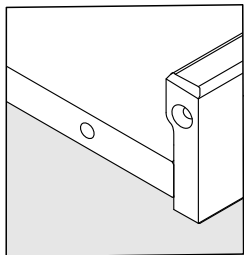

05

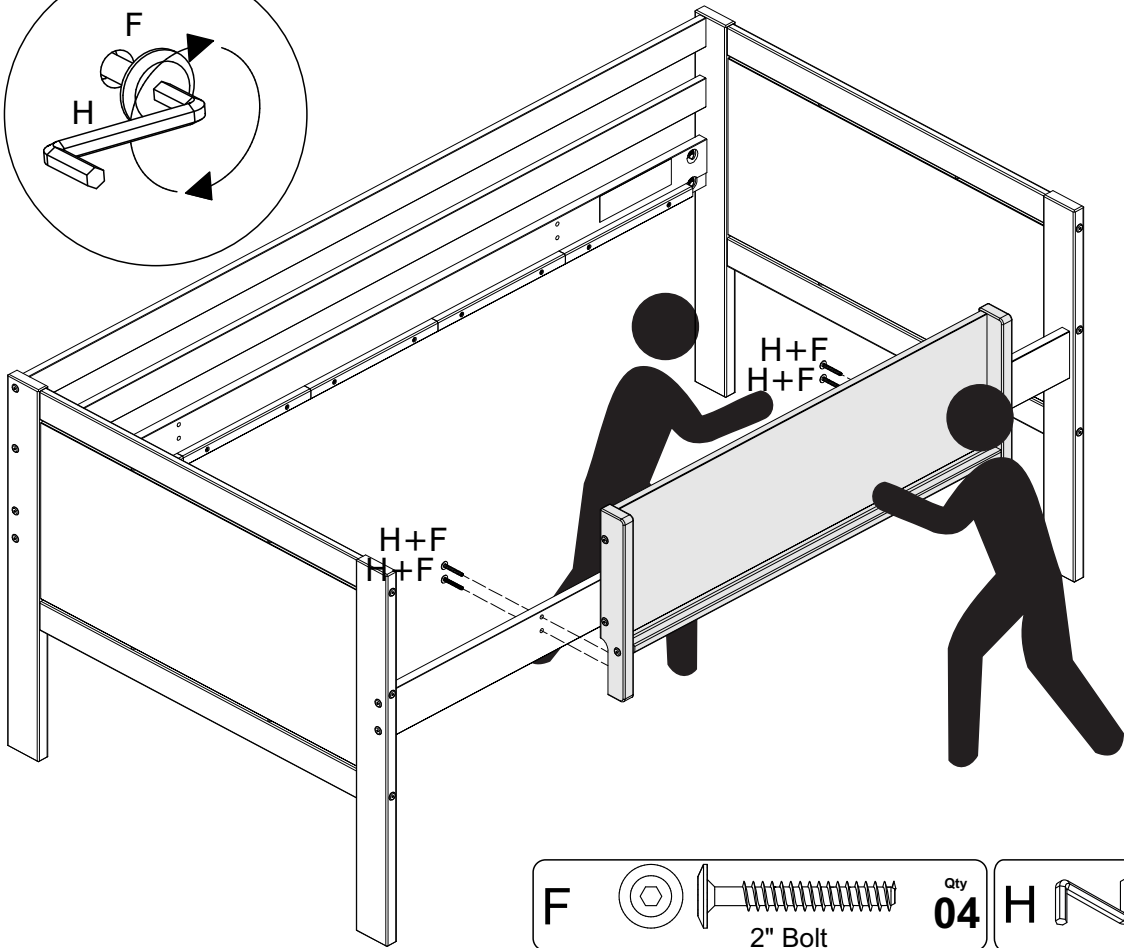
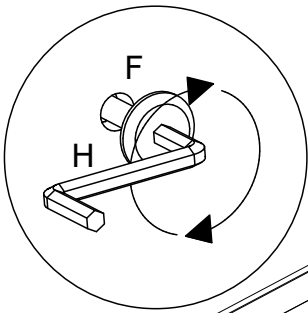

F  Qty **04**
2" Bolt

H  Qty **01**
Allen wrench

06

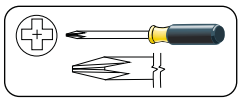
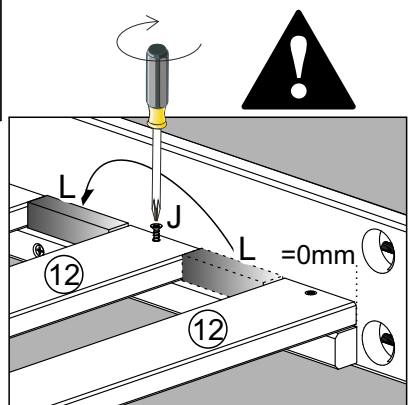
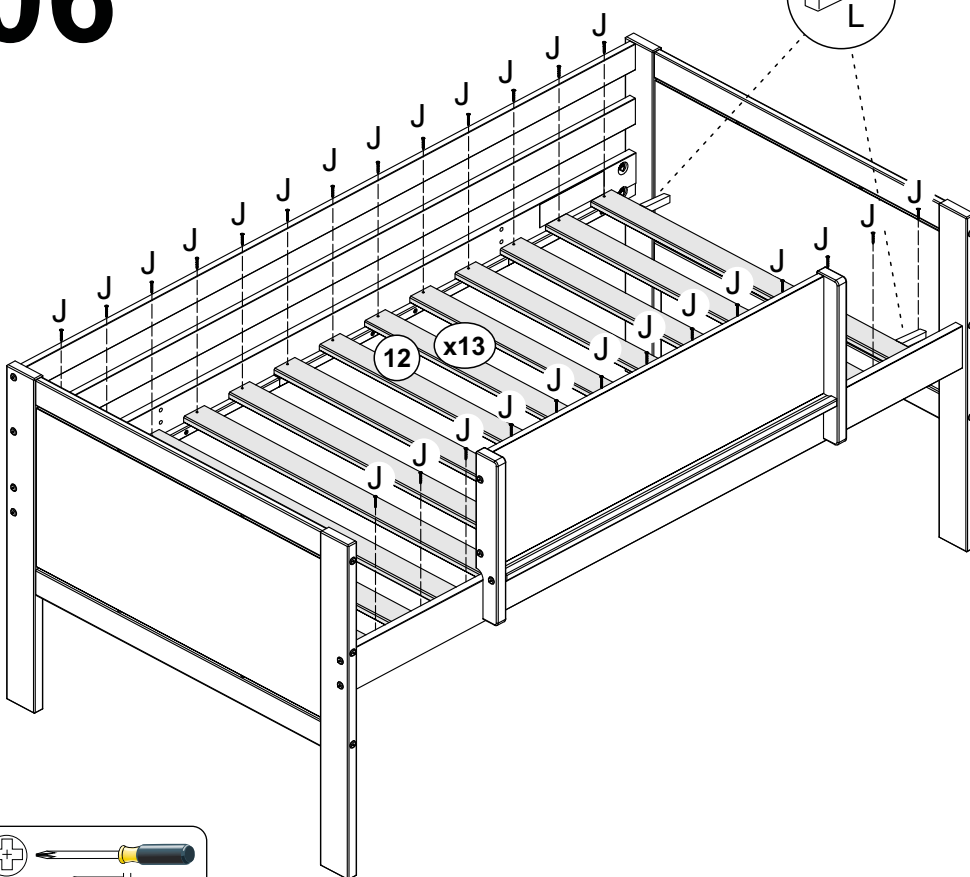
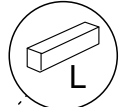

J  Qty **26**
1 3/16" Screw

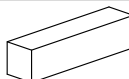
L  Qty **02**
Wooden spacer
2 15/16" (75mm)

The first slats must be fixed to the end of the side rail bracket.
After fixed the first slat use the hardware letter L to help define the space between each next slats.
Use 1-L on the left side rail and 1-L on the right side rail

07 ACCESS

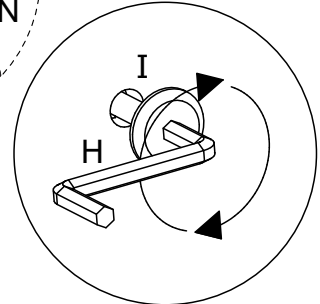
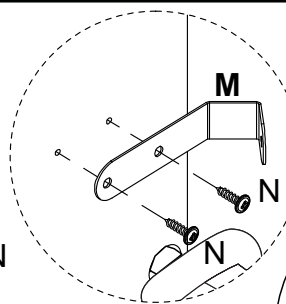
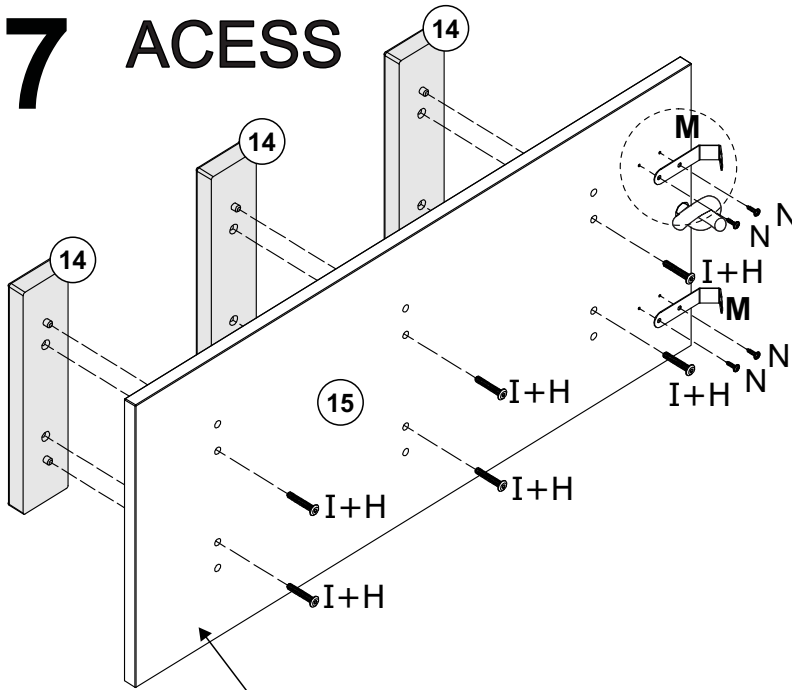

BOTTOM SIDE!

- H
Allen wrench
Qty 01
- I
1 9/16" Bolt
Qty 06
- M
Qty 02
- N
5/8" Screw
Qty 04

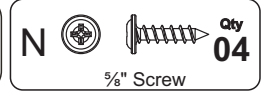
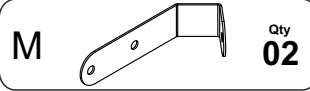
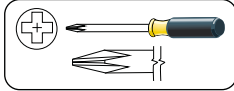

08

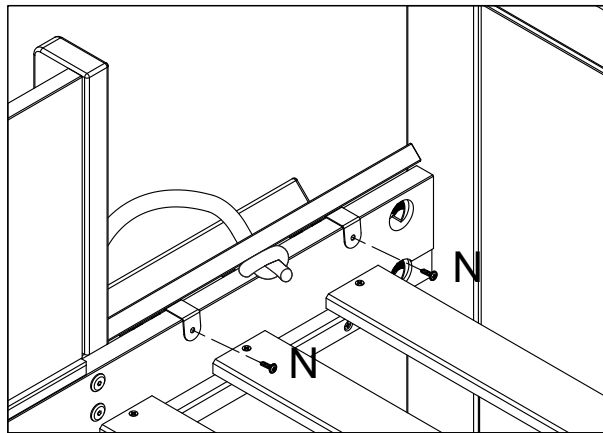

LEFT ACCESS OPTION

RIGHT ACCESS OPTION

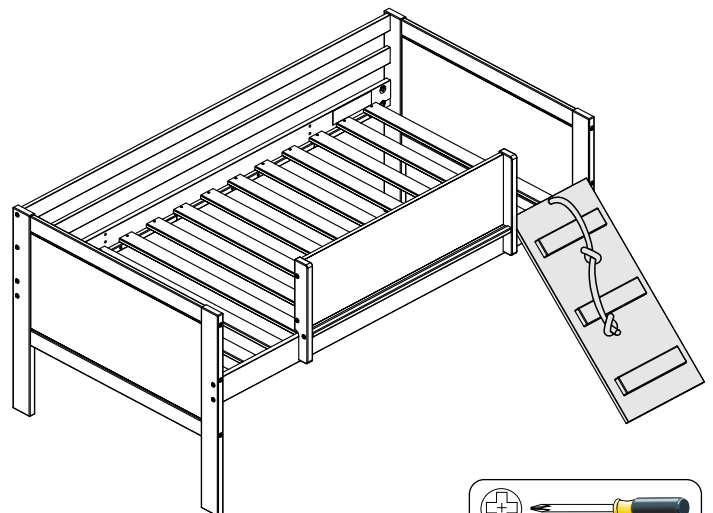
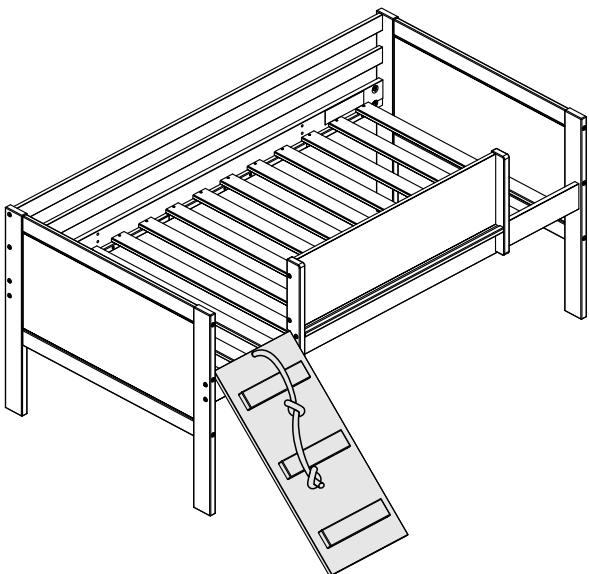

- +
- N
5/8" Screw
Qty 02

09

SLIDE

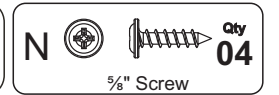
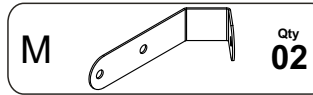
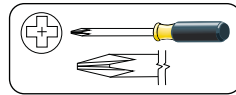
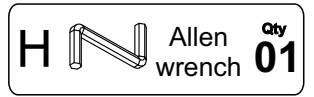
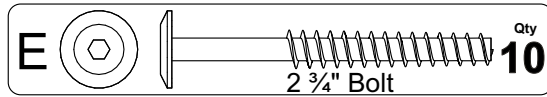
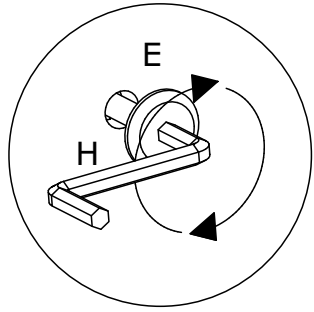
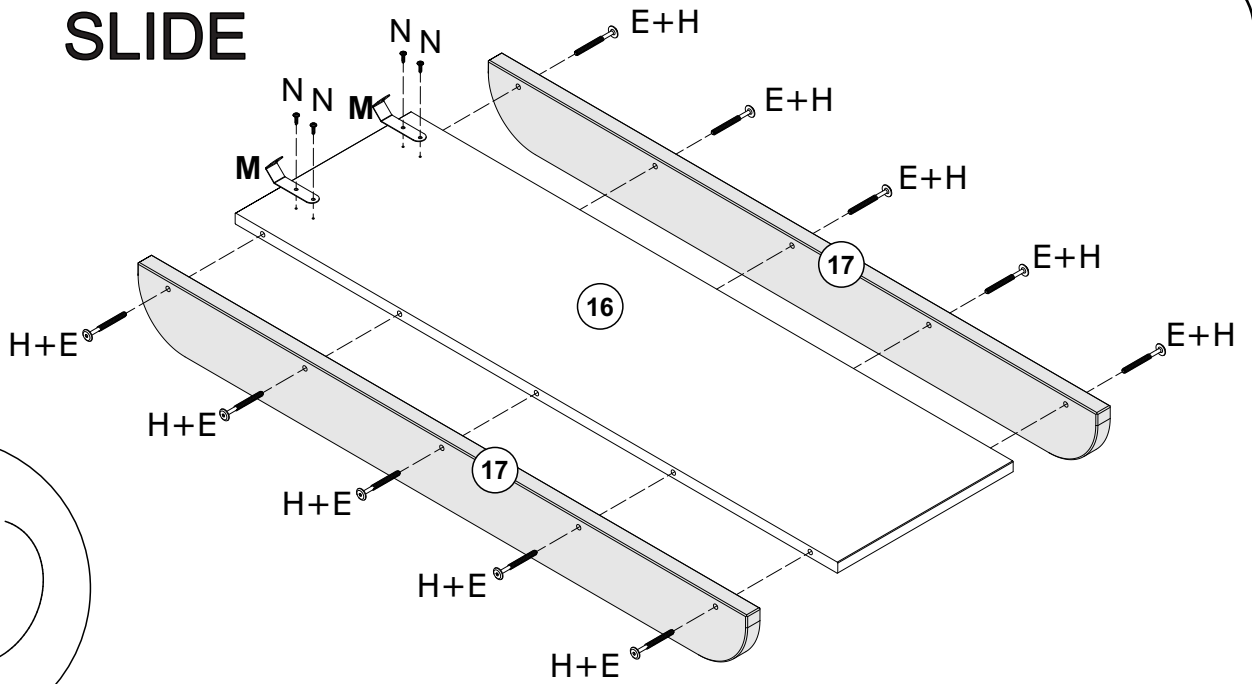

10

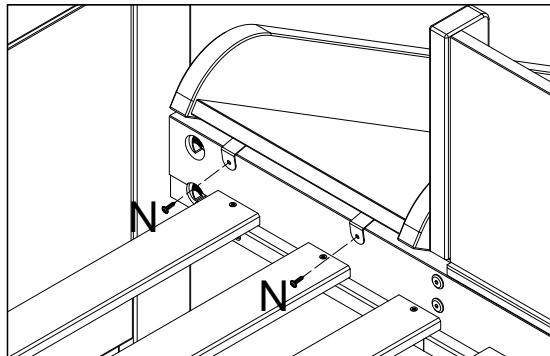

LEFT SLIDE OPTION

RIGHT SLIDE OPTION

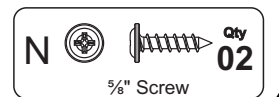
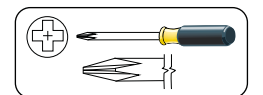
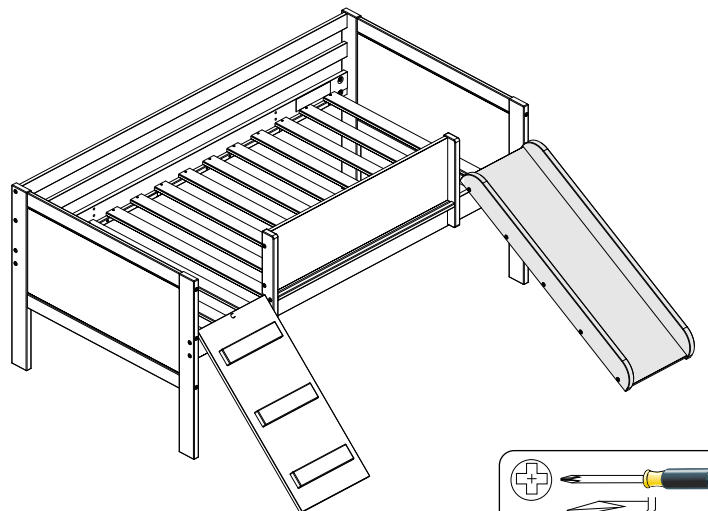
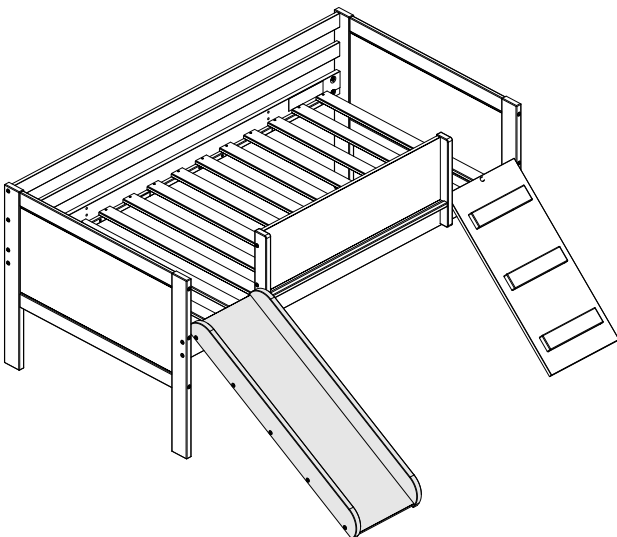

11

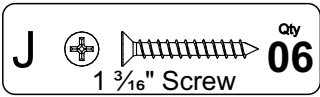
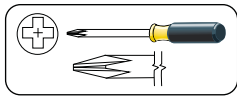
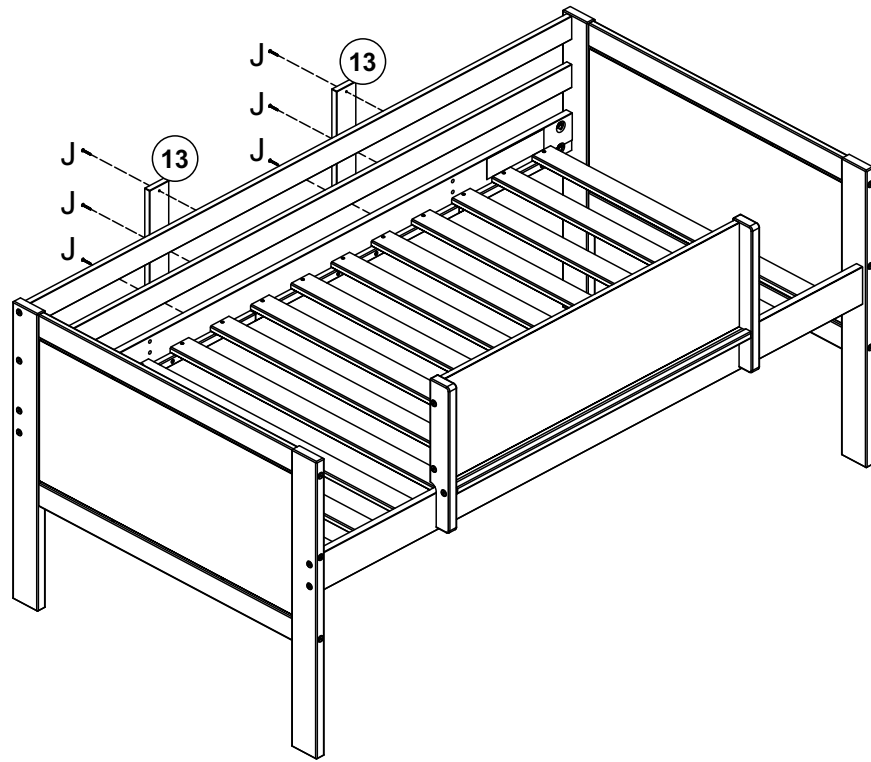

TOY BOX IS OPTIONAL

