

SAFETY INFORMATION



Please read and understand this entire manual before attempting to assemble, operate or install the product.



WARNING

- Some steps are more easily handled with two adults.

CAUTION

- Before assembly and/or installation, carefully unwrap all parts.
- Locate and set aside the hardware kit before discarding packaging.
- Use care when assembling your new product. Take your time and follow assembly instructions closely.

INFORMATION DE SÉCURITÉ



Assurez-vous de lire et de comprendre l'intégralité du présent manuel avant de tenter d'assembler, d'utiliser ou d'installer le produit.



AVERTISSEMENT

- Certaines étapes sont plus faciles à effectuer avec l'aide.

MISE EN GARDE

- Avant l'assemblage et/ou l'installation, vous devez débarrasser minutieusement toutes les pièces.
- Localisez et mettez de côté le jeu de quincaillerie avant de jeter l'emballage.
- Soyez vigilant lorsque vous assemblez le nouveau produit. Prenez votre temps et suivez attentivement ces instructions.

INFORMACIÓN DE SEGURIDAD



Lea y comprenda completamente este manual antes de intentar ensamblar, usar o instalar el producto.



ADVERTENCIA

- Algunos de los pasos se pueden realizar con mayor facilidad entre dos adultos.

PRECAUCIÓN

- Antes del ensamblaje y/o instalación, desenvuelva cuidadosamente todas las piezas.
- Localice y separe el equipo de accesorios antes de desechar el embalaje.
- Tenga cuidado al ensamblar el nuevo producto. Tómese su tiempo y siga detenidamente las instrucciones de ensamblaje.

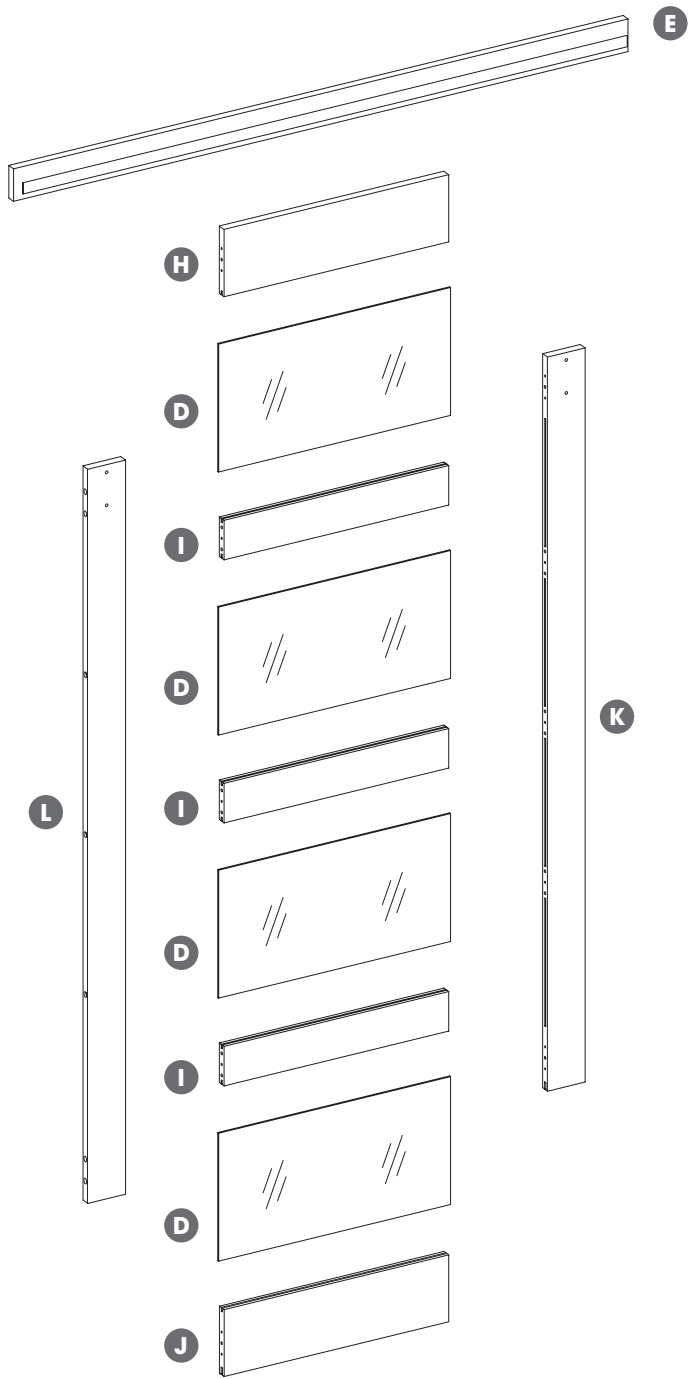

HARDWARE/QUINCAILLERIE/FERRETERÍA

AA

[x5]



Ø8x80mm
PH-8X80MMBOLT-AA

BB

[x5]

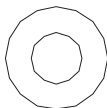

Ø16mm
PH-WSRBLK002

EE

[x16]



Ø8x40mm
PH-8X40MMDOWEL-EE

FF

[x2]

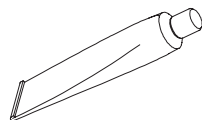

PH-GLUETUBE-FF

GG

[x6]

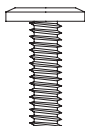

Ø6.3x25mm
PH-6.3X25MMBOLT-GG

HH

[x1]

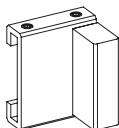

PH-SDSTOPPER-HH

II

[x1]



A5478
PH-SDHANDLEA5478-II

JJ

[x2]

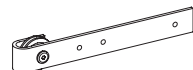

PH-BDRBLK004

KK

[x1]

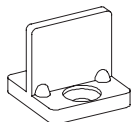

PH-SDFLOORGUIDE-KK

LL

[x2]



Ø 4x31mm
PH-SCRBLK014

MM

[x1]

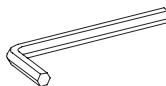

PH-SDKEYROLLERS-MM

NN

[x1]

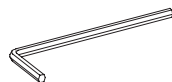

PH-SDKEYSTOPPER-NN

OO

[x1]



PH-SDDECALSPE02-OO
PH-SDDECALSPT85-OO
PH-SDDECALSP0140-OO

PP

[x1]

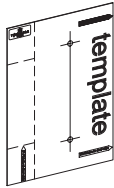

PH-TEMPLATE6964-PP

SS

[x14]



Ø6.3x139mm
PH-6.3X139MMBOLT-SS

TT

[x14]

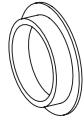

PH-SDBOLTCAPE02-TT
PH-SDBOLTCAPPT85-TT
PH-SDBOLTCAPPO140-TT

UU

[x4]



PH-SDBOLTCAPE02-UU
PH-SDBOLTCAPPT85-UU
PH-SDBOLTCAPPO140-UU

VV

[x1]

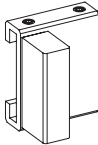

PH-SDSTOPPER-VV

**TOOLS YOU WILL NEED
OUTILLAGE NÉCESSAIRE
HERRAMIENTAS QUE SE NECESITAN**

Phillips Screwdriver

Tournevis à tête Phillips

Destornillador de punta Phillips



Drill Bit:
For wood: 6 mm / 1/4 in



Foret:
Pour bois : 6 mm / 1/4 po

Broca:
de 6 mm para madera o

Drill

Perceuse

Taladro

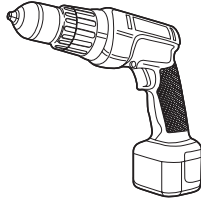

Pencil

Crayon

Lápiz



Level Niveau Nivel

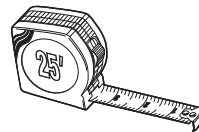

Tape Measure

Ruban à mesurer

Cinta métrica

Stud Finder

Détecteur de montant

Localizador de montantes



ATTENTION: Follow instructions in the order they are given below. This will ensure that your product is properly assembled. To reduce the risk of damage to your furniture, please lay down a blanket, cloth, or cardboard on the floor prior to assembly.

ATTENTION : Suivre les instructions dans l'ordre donné ci-dessous. Cela vous assurera d'assembler correctement le produit. Para reducir el riesgo de daño a sus muebles, por favor coloque una manta, tela o cartón en el suelo antes del montaje.

ATENCIÓN: Siga las instrucciones en el orden que se indica a continuación. Esto asegurará que su producto se ensamble correctamente. Pour réduire le risque d'endommager vos fournitures, veuillez les poser sur un tapis, un tissu ou un carton sur le sol avant l'assemblage.

1

EE



[x16]

FF

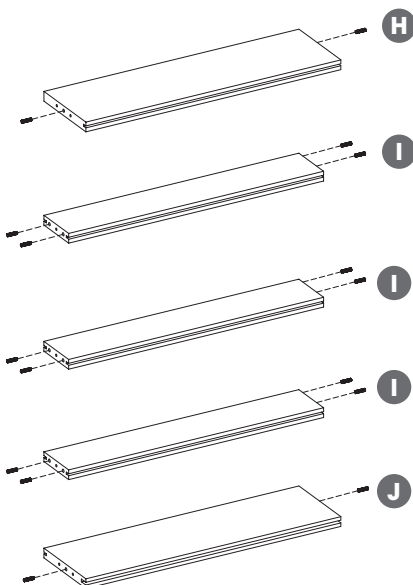
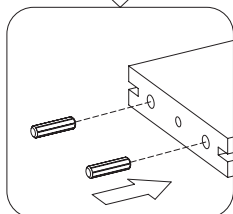
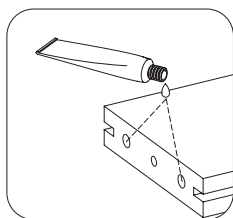

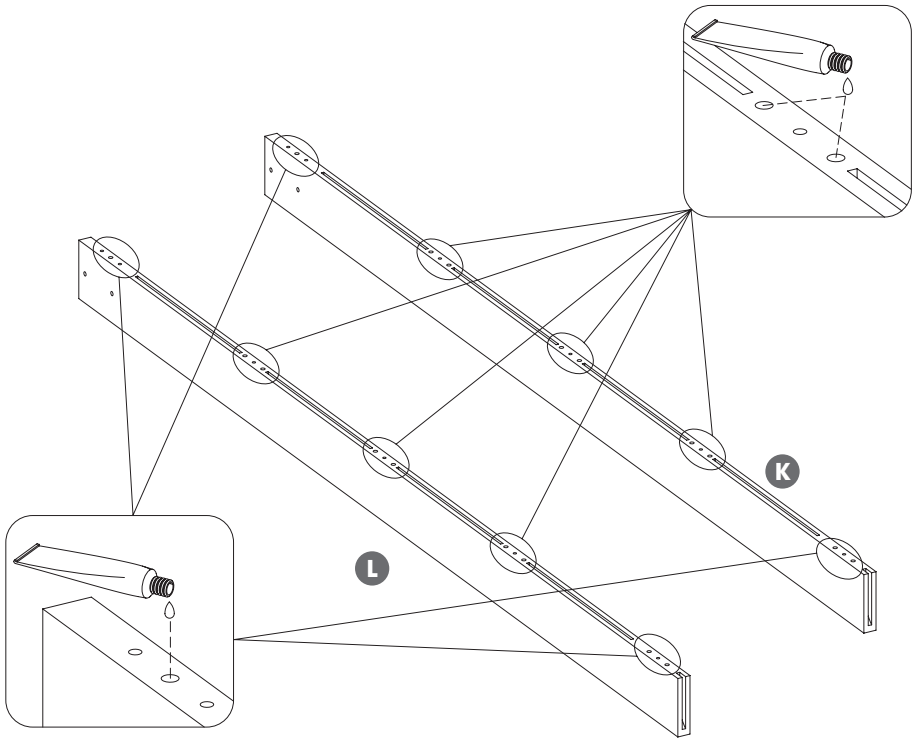
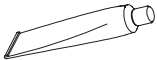

3

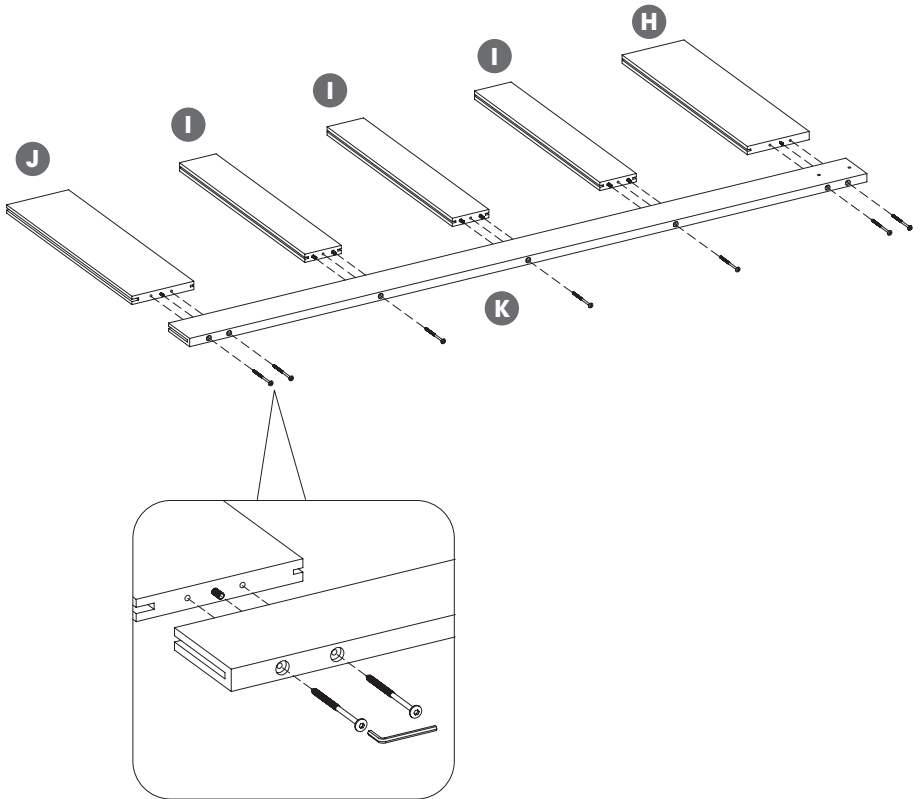
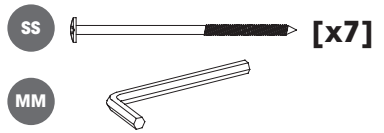

4

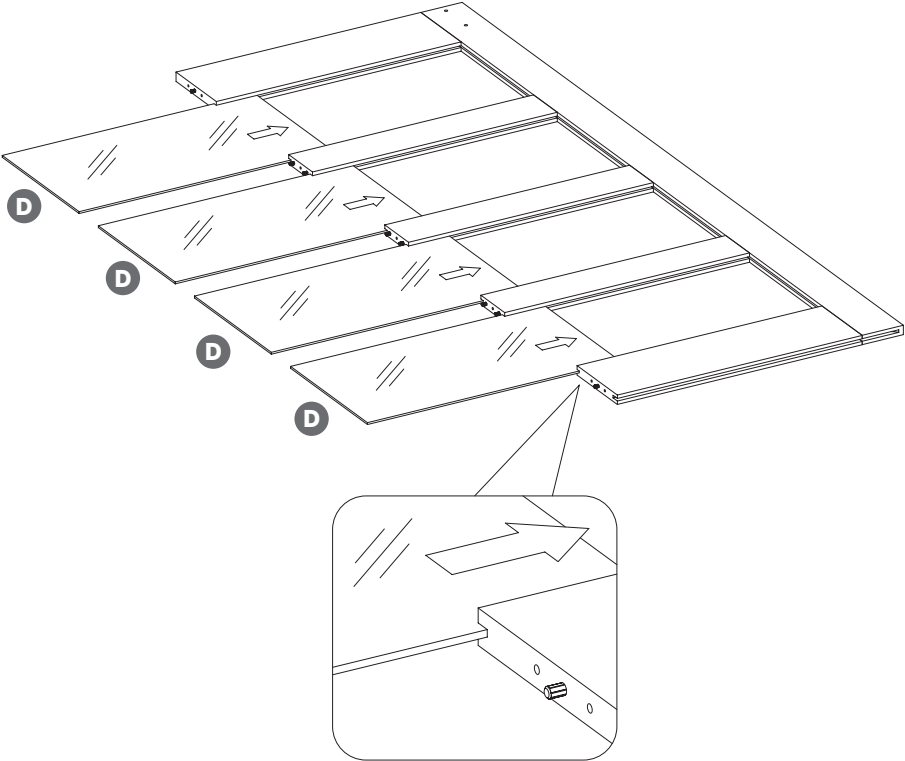

5

SS [x7]

MM

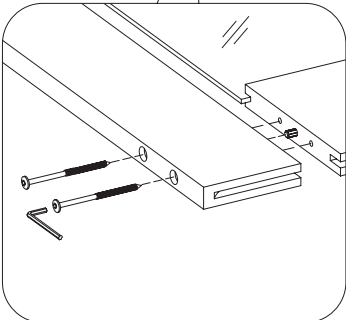
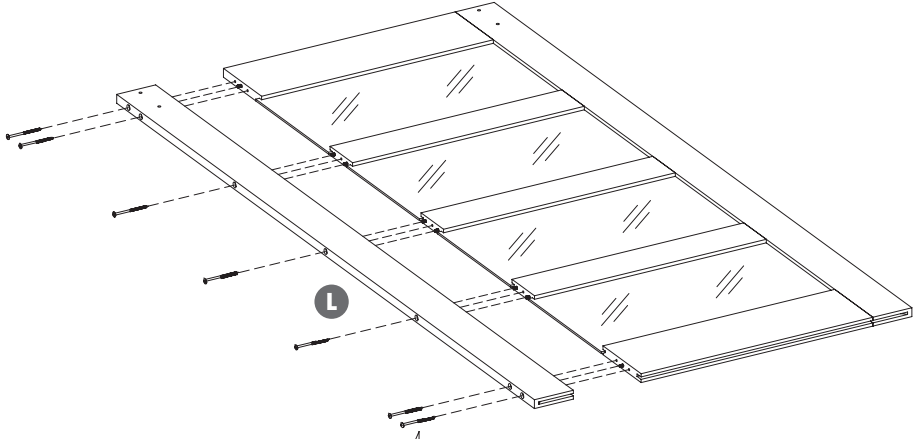
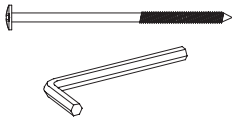

6

∞



[x1]

π

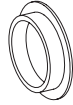

[x14]

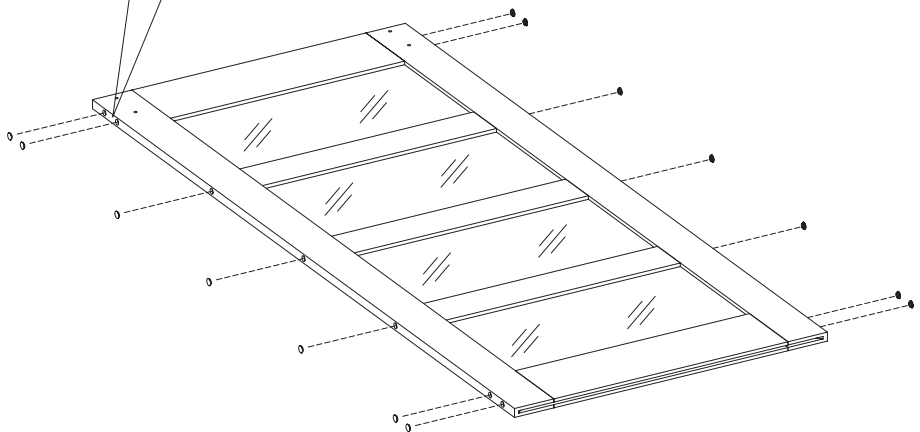
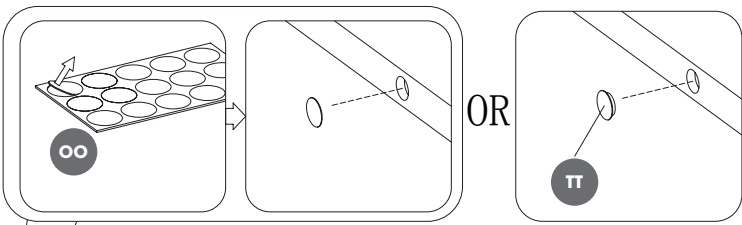

7

oo



[x1]

uu



[x4]

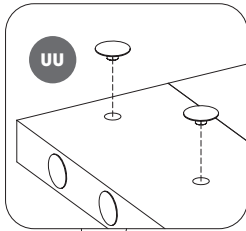

OR

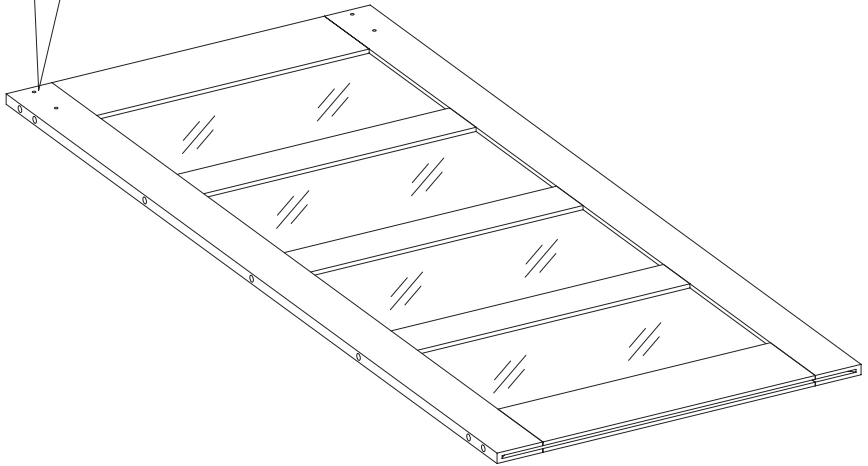
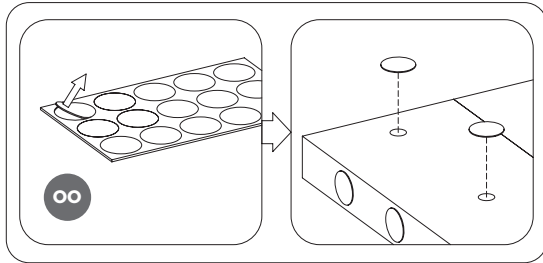

8

JJ

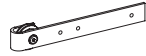

[x2]

GG

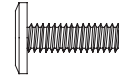

[x4]

MM

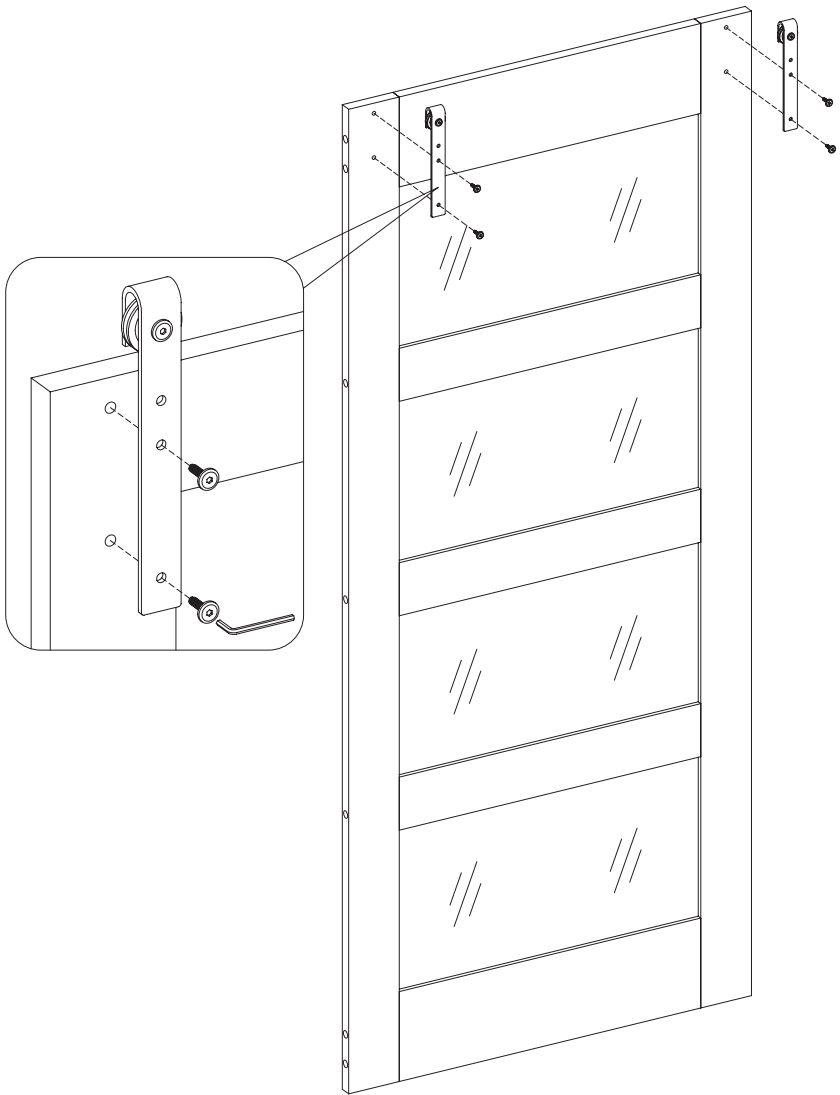
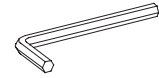

9

PP

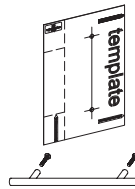

[x1]

II

[x1]

Note: Door can be used with or without the included handle. If you wish to install the handle, please use the enclosed drilling template.

Note: La porte peut être utilisée avec ou sans la poignée comprise. Si vous voulez installer la poignée, veuillez utiliser le gabarit de perçage entouré.

Nota: La puerta se puede utilizar con o sin la manija incluida. Si desea instalar la manija, utilice la plantilla de perforación adjuntada.

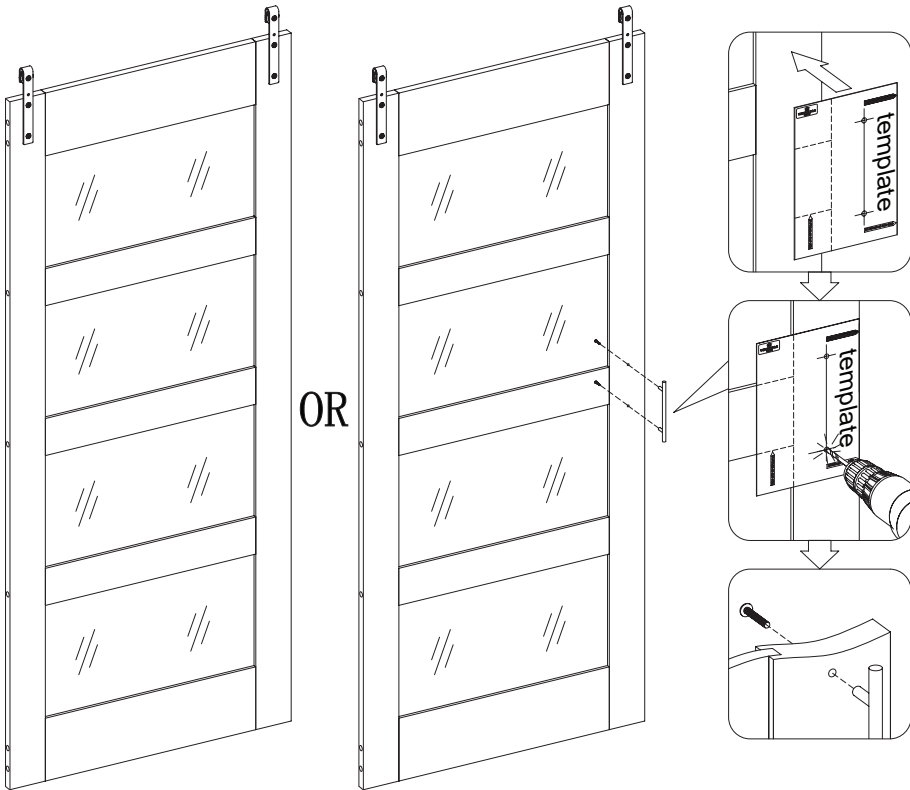

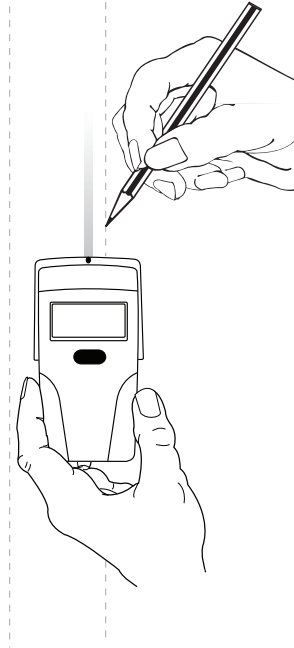

NOTE: Hardware included is for drywall installation only. For all other wall types, please visit your local hardware store to obtain the proper hardware.

Using a stud finder, **FIND** the exact location of the studs to which you want to attach the unit. **MARK** the right and left side to determine the center of each stud.

À l'aide d'un détecteur de montant, **TROUVER** l'emplacement exact des montants sur lesquels doit être attaché. **MARQUER** les bords gauche et droit pour déterminer le centre de chaque montant.

Utilizando un localizador de montantes, **DETERMINAR** la ubicación exacta de los montantes sobre los que desea fijar. **MARQUE** los lados derecho e izquierdo para determinar el centro de cada montante.

11

NOTE: Mark centerlines of wall studs as shown below. Bottom of mounting rail should be 83-3/4" from the floor. The center of the track should be mounted 1-1/2" from the edge of the door opening for optimal operation.

NOTE: Marquez líneas centrales de poteaux muraux comme ce qui illustré ci-dessous. Le fond du rail de montage doit être à 83-3/4" à partir du sol. Le centre du chemin doit être monté à 1-1/2" à partir du bord de l'ouverture de la porte pour l'opération optimale.

NOTA: Marque las líneas centrales de los montantes de la pared como se muestra a continuación. La parte inferior del riel de montaje debe estar a 83-3/4" del piso. El centro del riel debe montarse a 1-1/2" del borde de la abertura de la puerta para un funcionamiento óptimo.

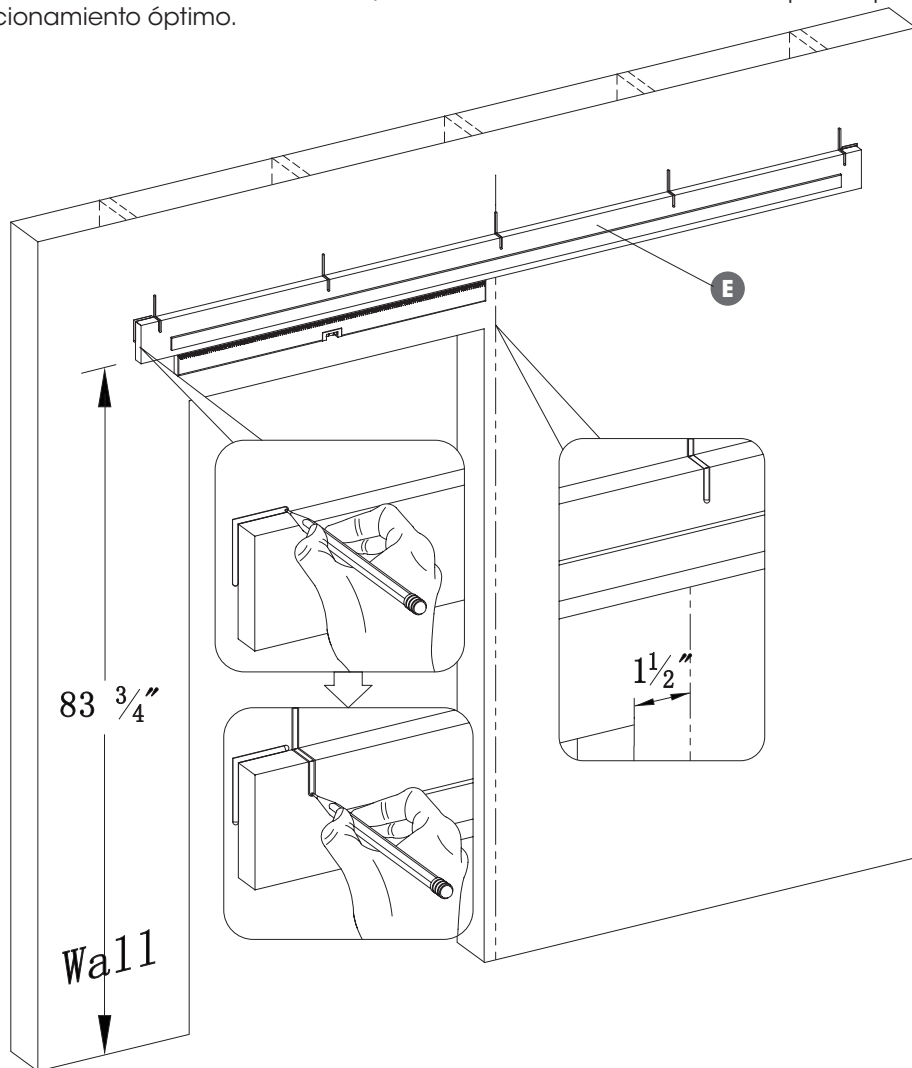

12

NOTE: Drill 3/8" through holes on the mounting rail so they will align with the wall studs. The holes should be drilled 1-1/8" from the top of the rail.

NOTE: Percez les trous de 3/8" sur le rail de montage afin qu'ils s'alignent avec les poteaux muraux. Les trous doivent être percés à 1 1/8" à partir du haut du rail.

NOTA: Perfore orificios pasantes de 3/8 "en el riel de montaje para que se alineen con los montantes de la pared. Los orificios deben perforarse a 1-1 / 8 "desde la parte superior del riel.

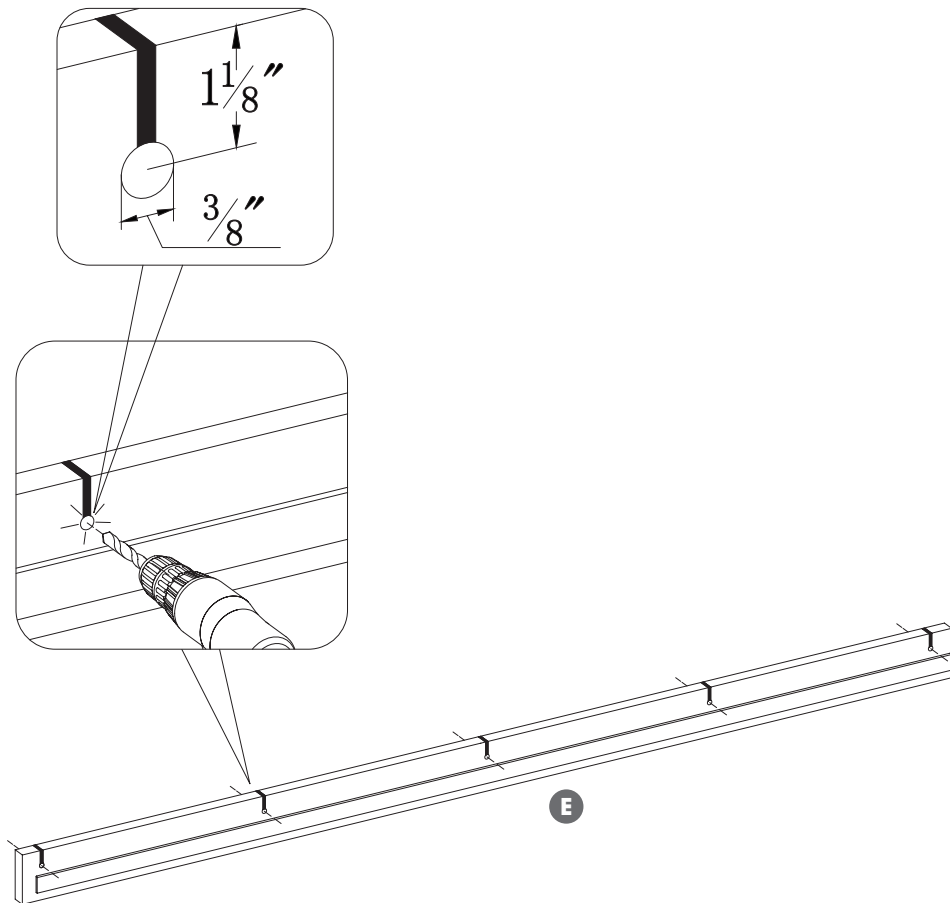

13

NOTE: Place mounting rail on wall aligning with markings from step 15. Mark hole locations through mounting holes and onto wall. Drill 1/4" D x 2" deep pilot holes into the wall studs.

NOTE: Placez le rail de montage sur le mur en alignant avec les marques à partir de l'étape 15. Marquez les localisations du trou à travers les trous de montage et sur le mur. Percez les trous pilotes 1/4 "D x 2" en profondeur dans les poteaux du mur.

NOTA: Coloque el riel de montaje en la pared alineándolo con las marcas del paso 15. Marque la ubicación de los orificios a través de los orificios de montaje y en la pared. Perfore los orificios de guía de 1/4 "de profundidad x 2" de profundidad en los montantes de la pared.

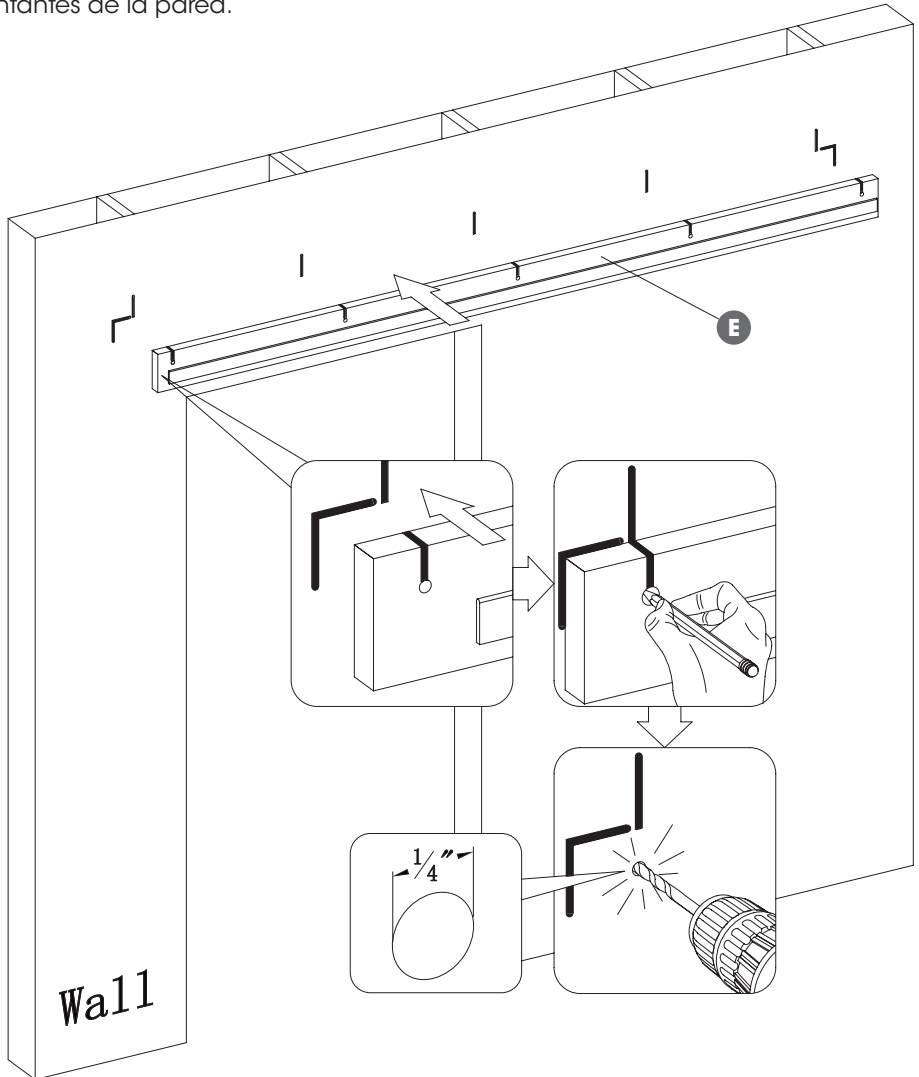

14

AA [x5]



BB [x5]



Note: Mounting bolts AA (X5) must be screwed into the wall stud.

Note: Les boulons de montage AA (X5) doivent être vissés dans le poteau mural.

Note: Les boulons de montage AA (X5) doivent être vissés dans le poteau mural.

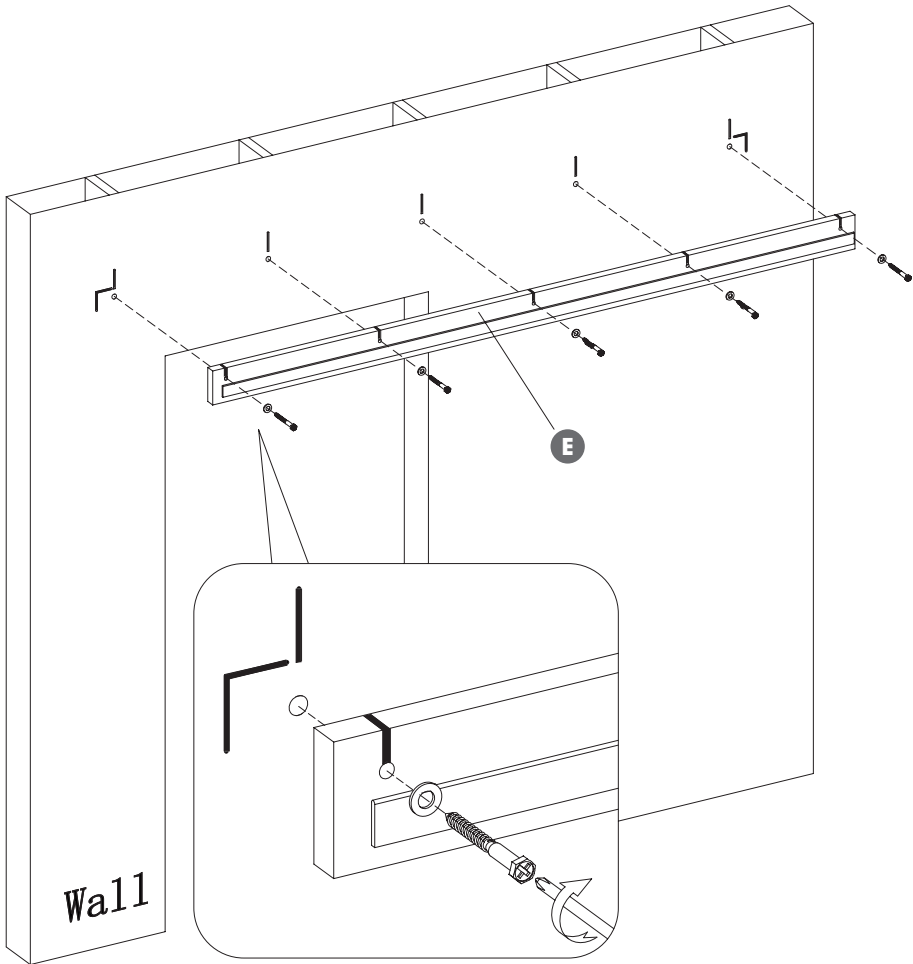

15

KK



[x1]

LL



[x2]

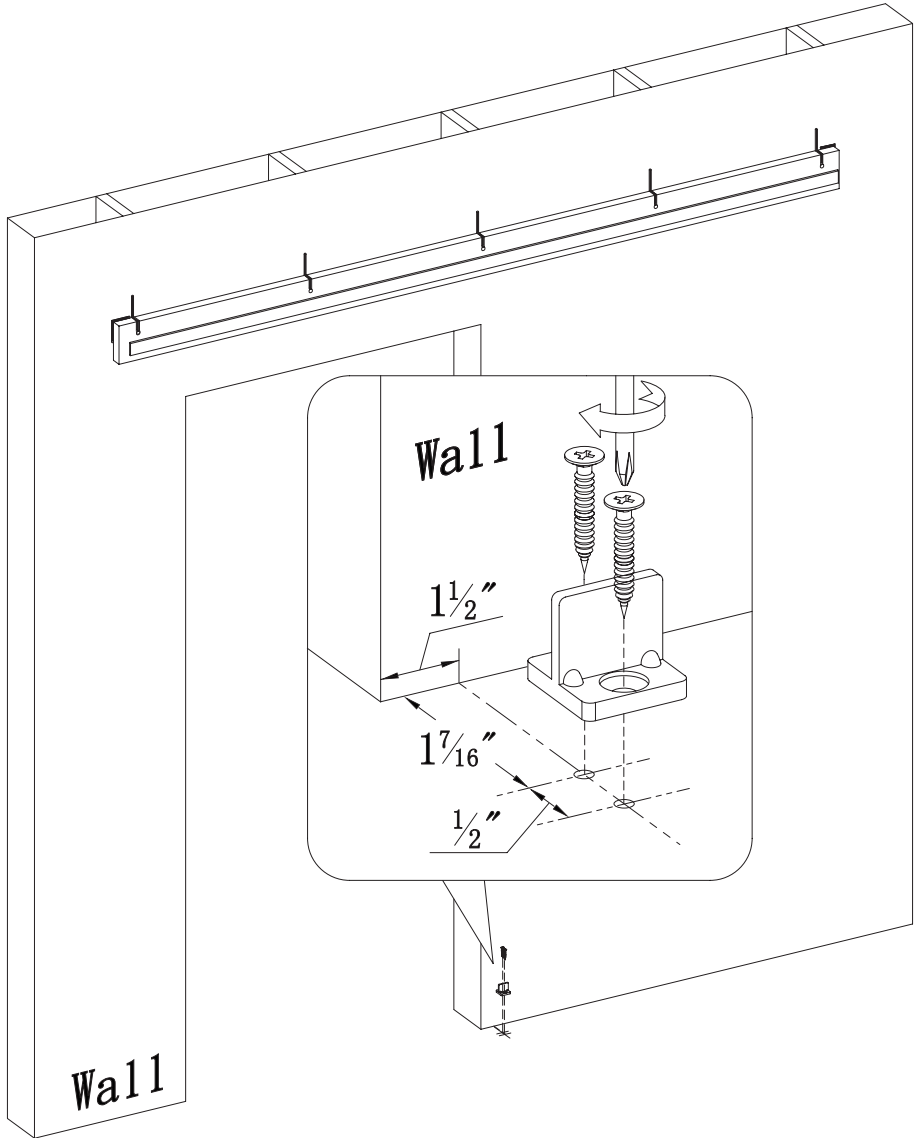

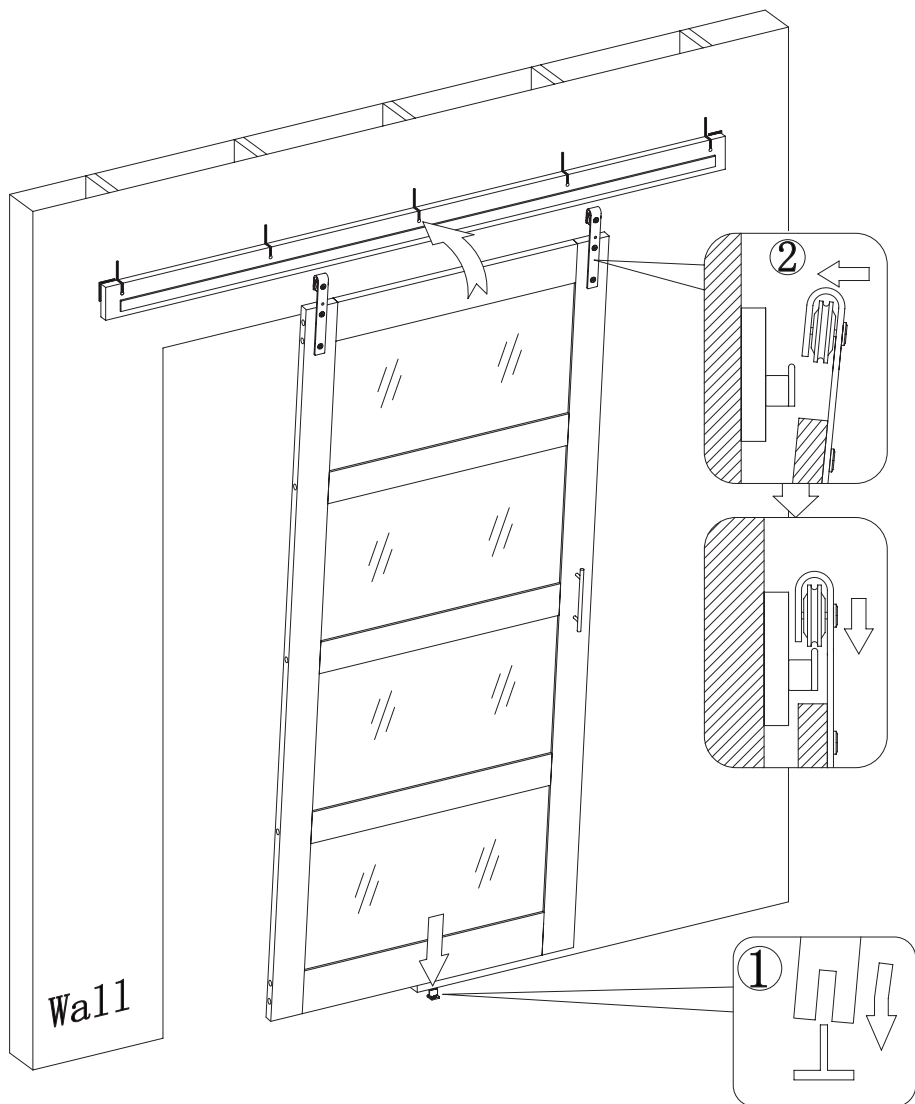

17

GG

MM

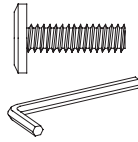

[x2]

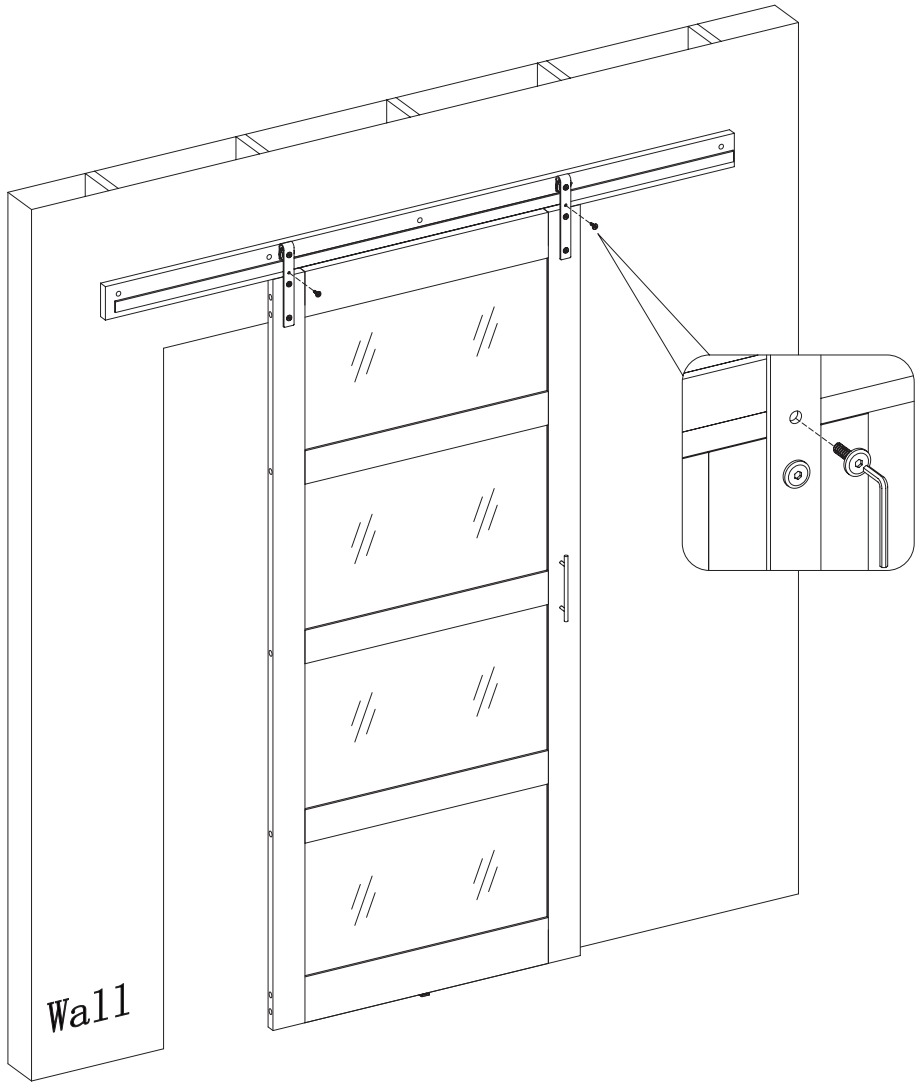

18

- HH [x1]
- VV [x1]
- NN

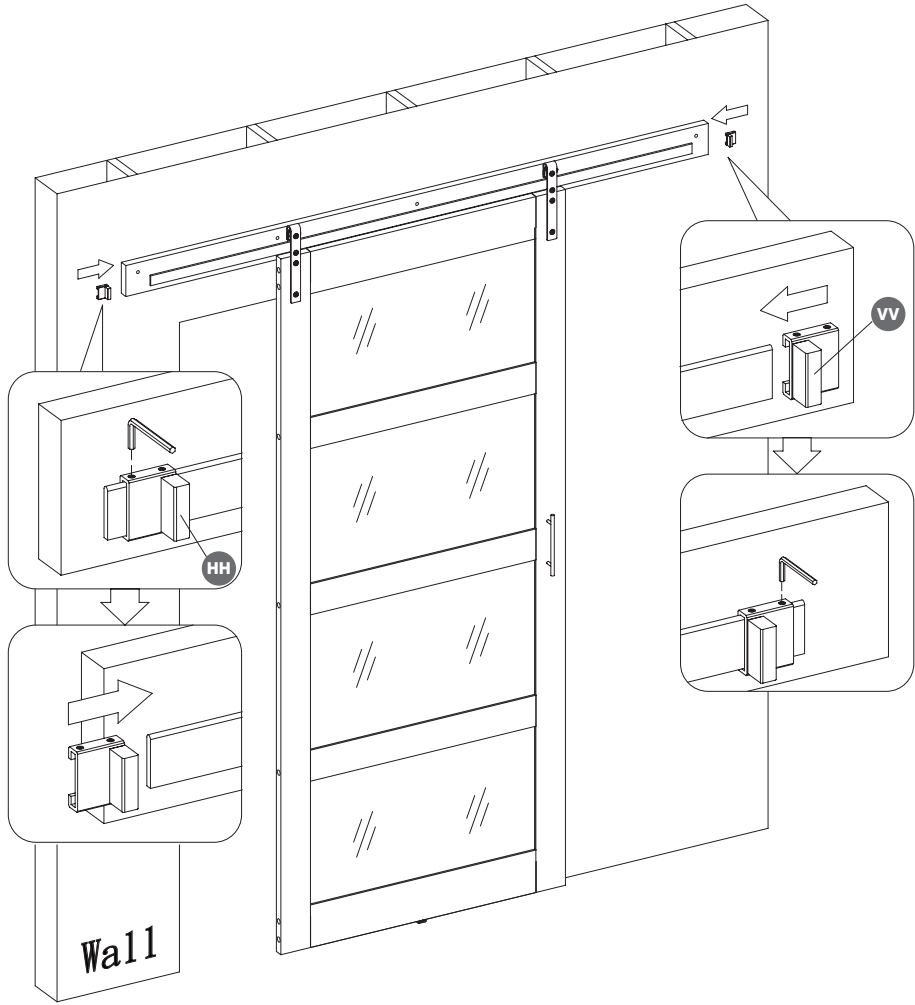

Care and Maintenance

- Use a soft, clean cloth that will not scratch the surface when dusting.
- Use of furniture polish is not necessary. Should you choose to use polish, test first in an inconspicuous area.
- Using solvents of any kind on your furniture may damage the finish.
- Never use water to clean your furniture as it may cause damage to the finish.
- Liquid spills should be removed immediately, as it may damage the furniture. Use a soft, clean cloth and blot the spill gently. Avoid rubbing.

Further advice about wood furniture care

It is best to keep your furniture in a climate-controlled environment. Temperature and humidity changes can cause fading, warping, shrinking and splitting of wood. It is advised to keep furniture away from direct sunlight as sun may damage the finish. Proper care and cleaning at home will extend the life of your purchase.

We hope you enjoy your purchase for many years. Thank you for your purchase!

Soin / Entretien

- Lors de l'époussetage, utilisez un chiffon doux et propre qui n'égatigne pas la surface.
- Il n'est pas nécessaire d'utiliser du poli à meuble. Si vous décidez d'utiliser du poli à meuble, veuillez d'abord en faire l'essai dans un endroit moins en évidence.
- L'utilisation de solvant de quelque sorte sur votre ameublement peut endommager le fini.
- Ne jamais utiliser d'eau pour nettoyer votre ameublement car cela peut endommager le fini.
- Tout déversement de liquide doit être enlevé immédiatement car cela peut endommager l'ameublement. Utilisez un chiffon doux et propre et épongez délicatement le déversement. Évitez de frotter.

Conseils supplémentaires pour l'entretien de meubles en bois

Il est préférable de garder vos meubles dans un environnement climatisé. Les changements de température et d'humidité peuvent décolorer, déformer, rétracter et fendiller le bois. Il est conseillé de garder les meubles à l'abri de la lumière directe du soleil car cela pourrait endommager le fini. L'entretien et le nettoyage appropriés à domicile prolongeront la vie de votre achat.

Nous espérons que vous apprécierez votre achat pendant de nombreuses années. Nous vous remercions pour votre achat!

Cuidado / Mantenimiento

- Use un paño suave y limpio que no raye la superficie cuando elimine el polvo.
- El uso de cera para muebles no es necesario. Si elige utilizar la cera, realice primero una prueba en un área discreta.
- Usar solventes de cualquier clase en sus muebles puede dañar el acabado.
- Nunca utilice agua para limpiar sus muebles, ya que puede causar daños en el acabado.
- Los derrames de líquidos se deben de secar inmediatamente, ya que pueden dañar el mueble. Use un paño suave y limpio y seque el derrame con cuidado. Evite frotar.

Consejos adicionales sobre el cuidado de los muebles de madera

Lo mejor es mantener sus muebles en un ambiente con clima controlado. Los cambios de temperatura y humedad pueden hacer que la madera se decolore, se combe, se encoja y se parta. Se aconseja mantener los muebles alejados de la luz solar directa, ya que esta puede dañar el acabado. El cuidado y la limpieza adecuados en casa extenderán la vida útil de su compra.

Esperamos que disfrute de su compra durante muchos años. ¡Gracias por su compra!

INSTALLED REPLACEMENT PARTS
PIÈCES DE REMPLACEMENT INSTALLÉES
PIEZAS DE REPUESTO INSTALADAS

RR

[x4]



PH-TNTZNC001