

80025 Product Installation Instructions

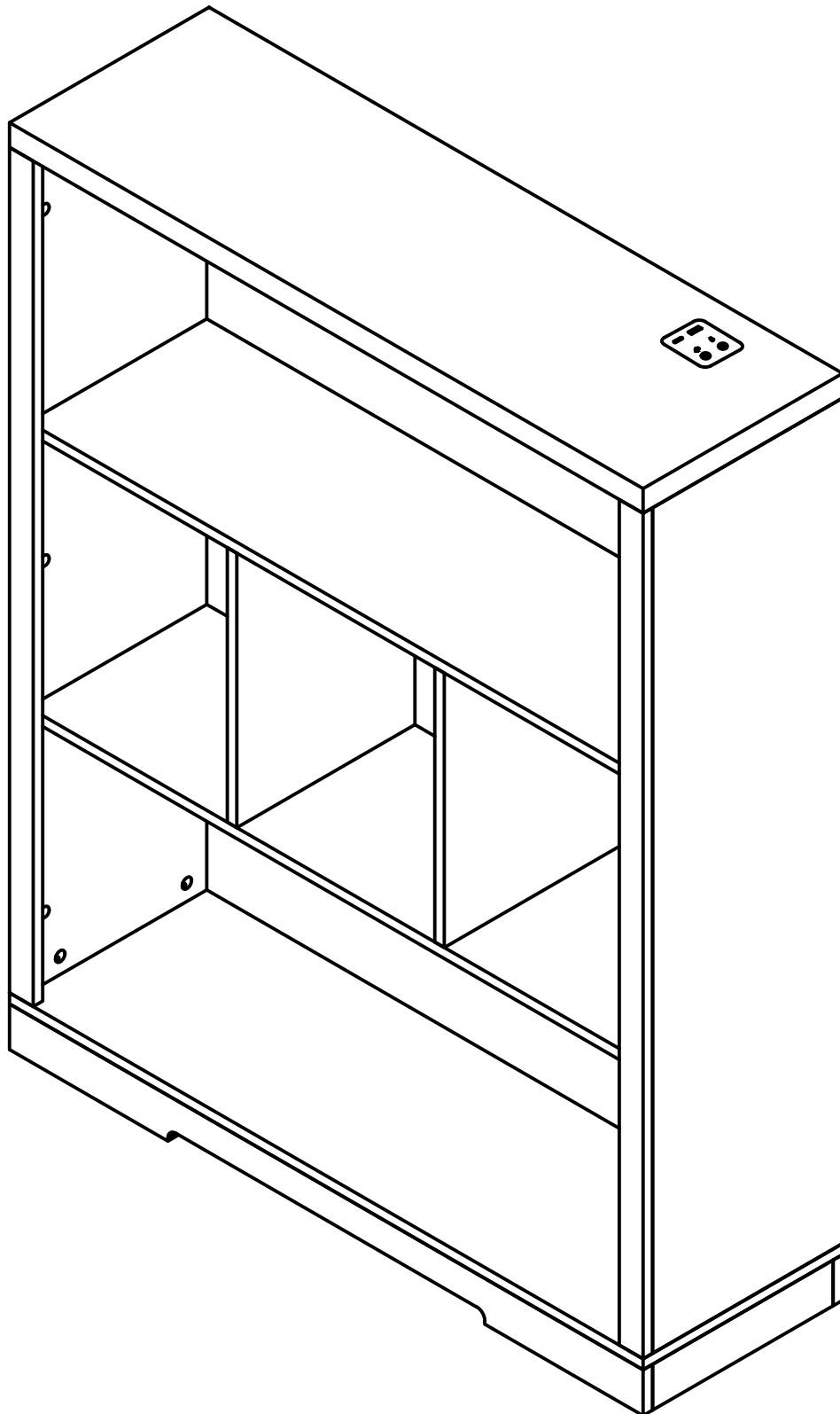

Product structure decomposition

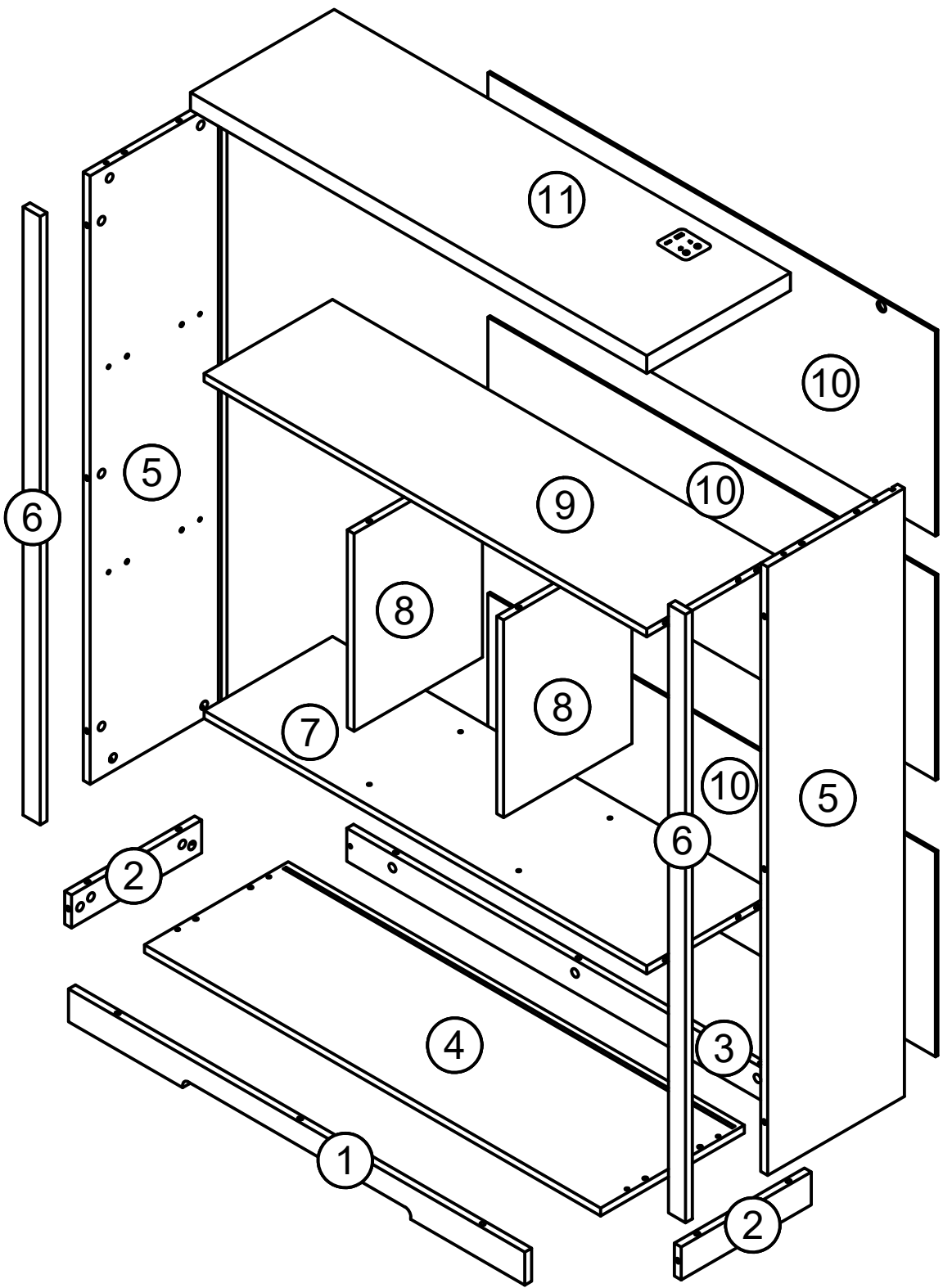

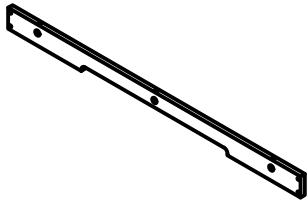

1x1

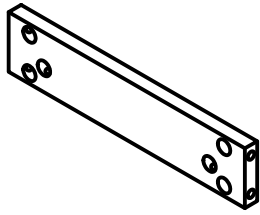

2x2

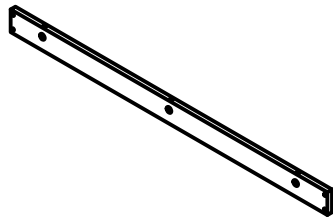

3x1

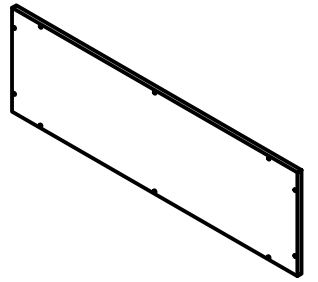

4x1

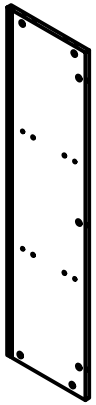

5x2



6x2

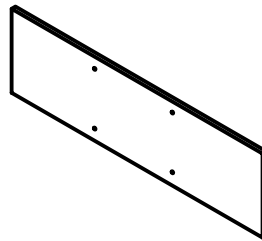

7x1

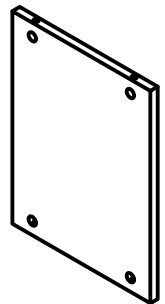

8x2

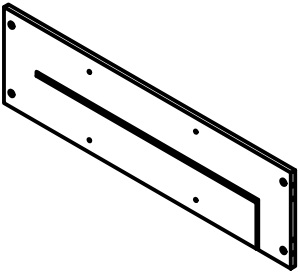

9x1

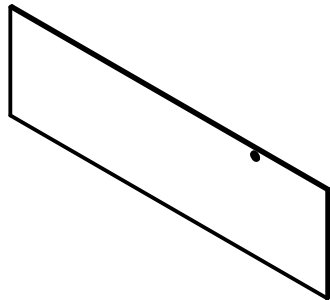

10x3

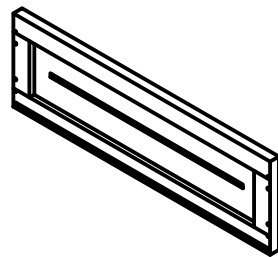



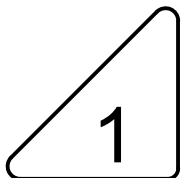



11x1

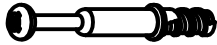

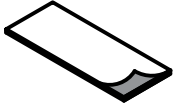
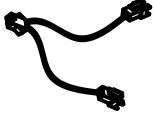
1

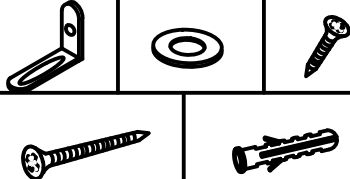
Accessories list



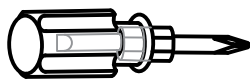



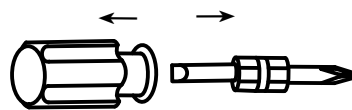



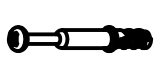

A		Two In One Screw (6x28mm)	42pcs +4pcs
B		Two In One Nut (10x12mm)	42pcs +4pcs
C		Wood Chipping (6x30mm)	16pcs +2pcs
D		Non-slip pads	6pcs +2pcs
E		1 bis 2 power extension cable	1pcs
F		Fixing clip & screw (3x16mm)	10pcs +3pcs
G		Foot nail	4pcs +2pcs
H		Anti fall hardware	2pcs
/		AC/DC Adapter (12V=3.0A)	1pcs



1pcs

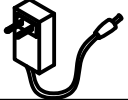

Double-head screwdriver, use as required

A		42 pcs	B		42 pcs	C		16 pcs
D		6 pcs	E		1 pcs	F	 	10 pcs
G		4 pcs	H	  	2 pcs		 	1 pcs

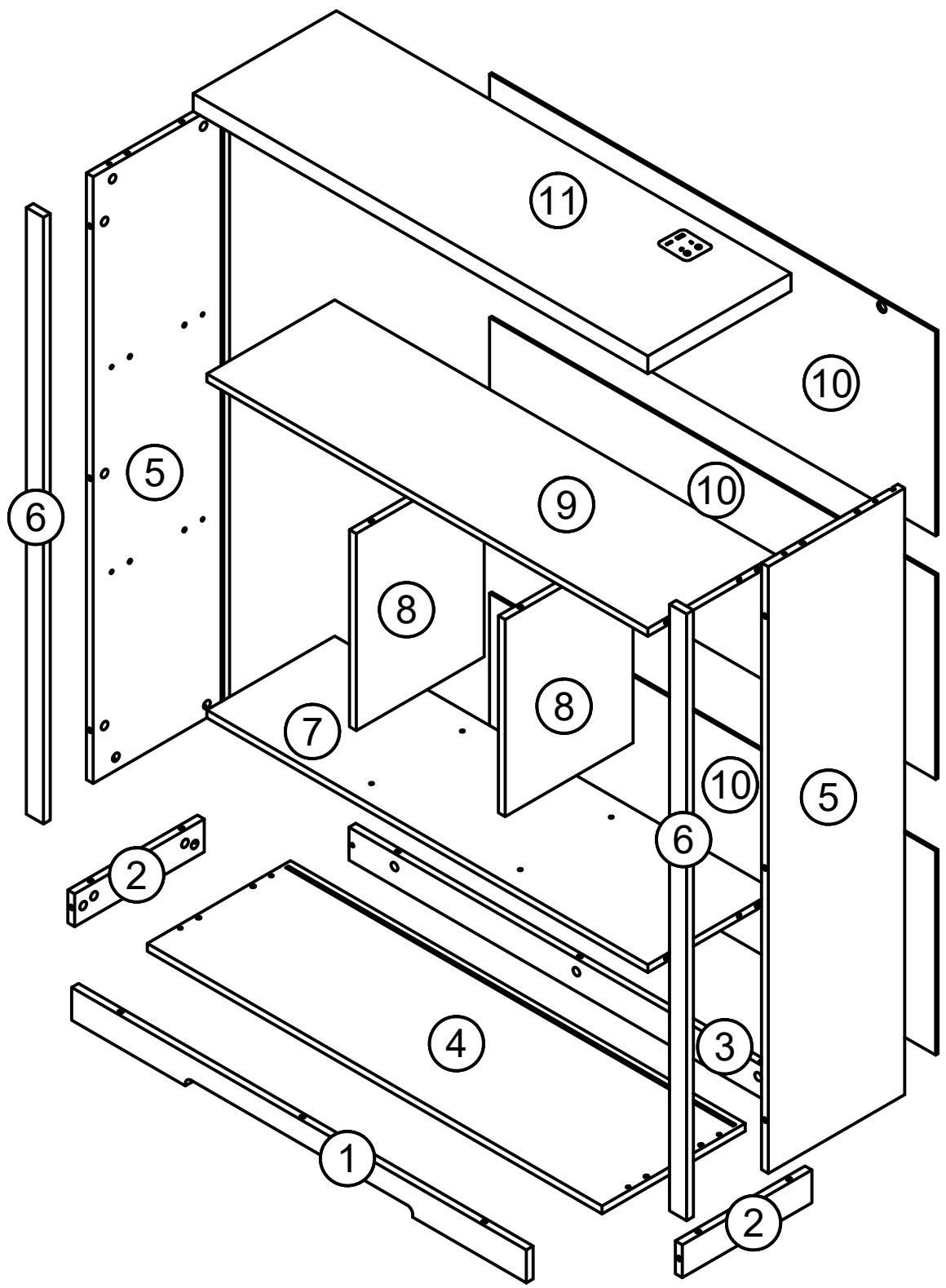

Step 1

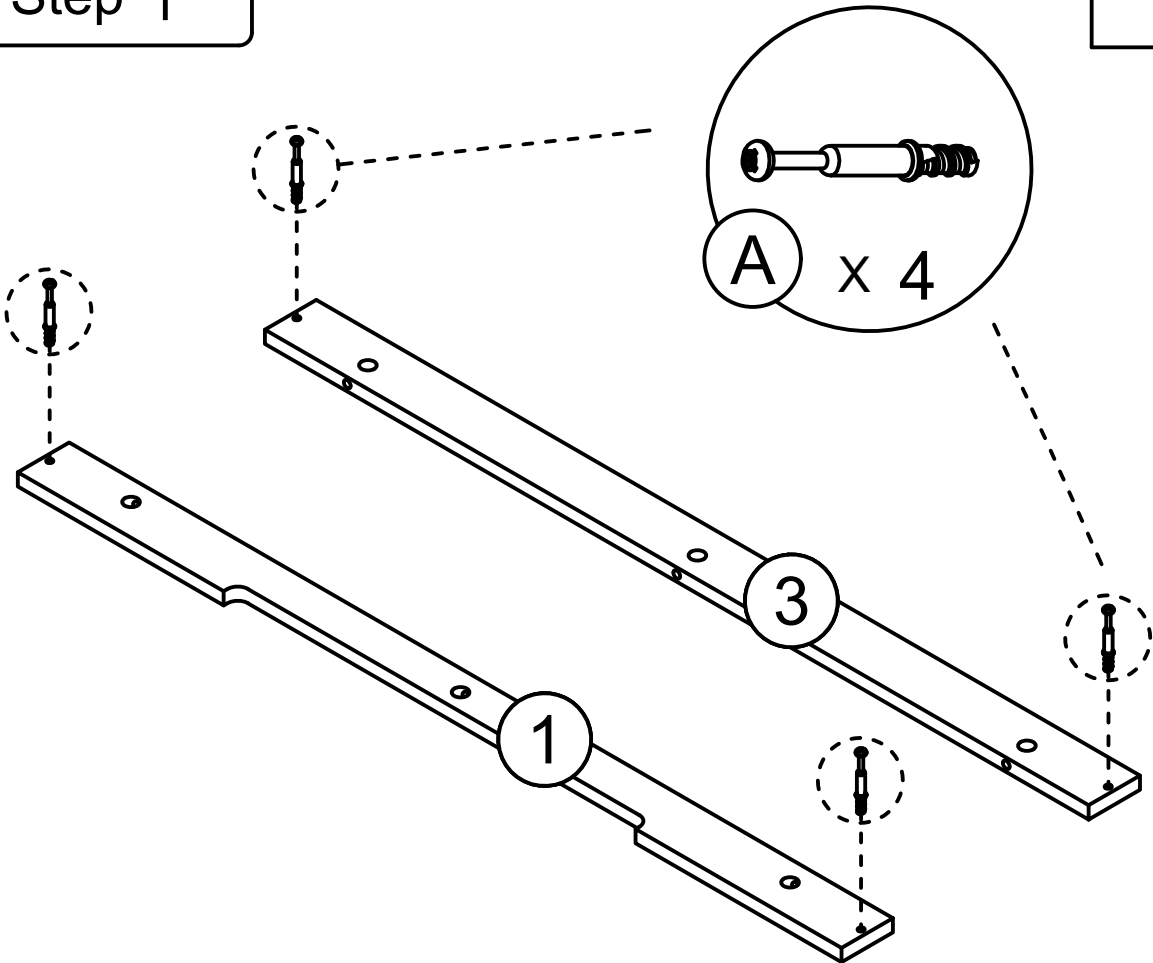
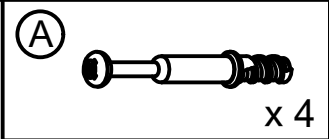

Step 2

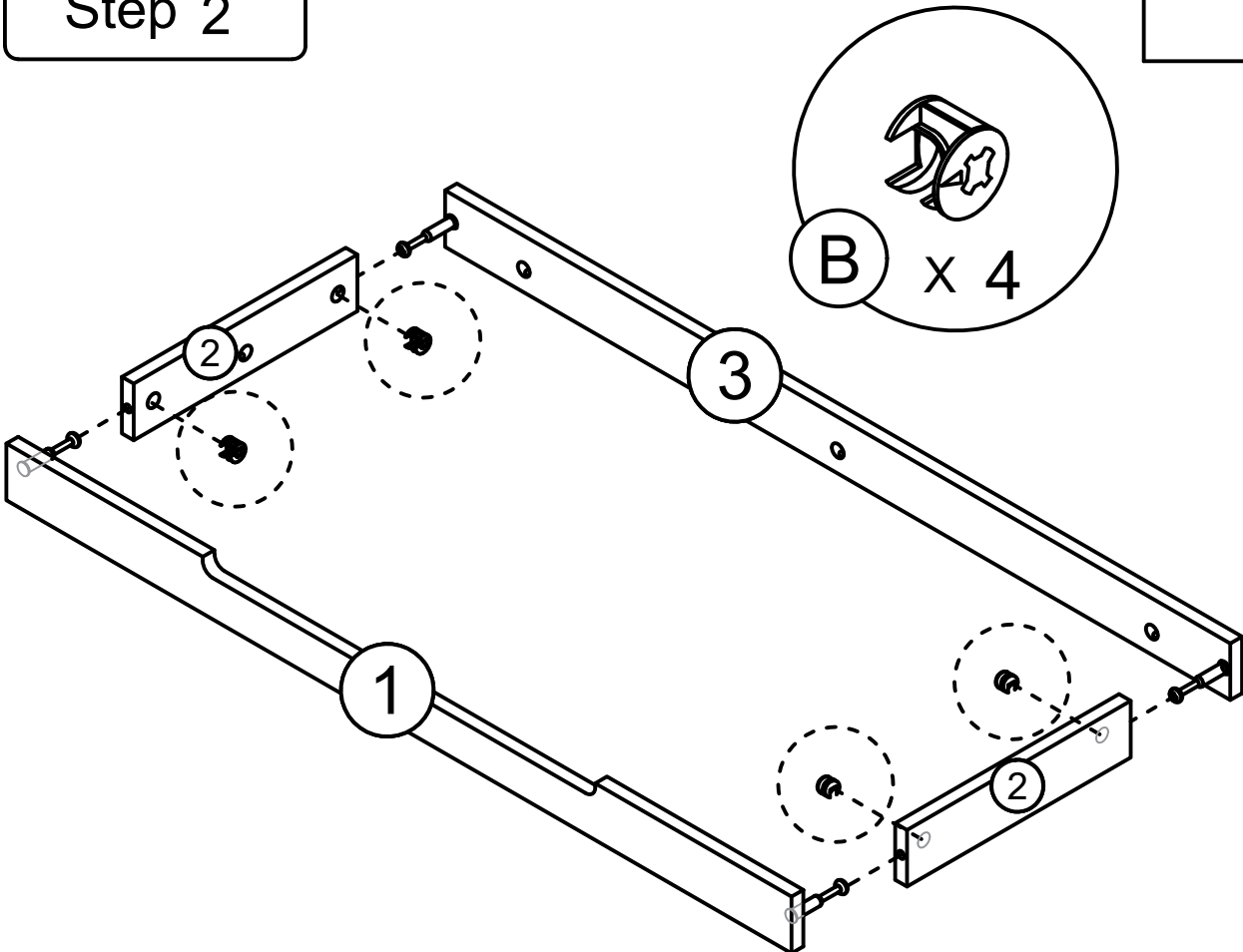

Step 3

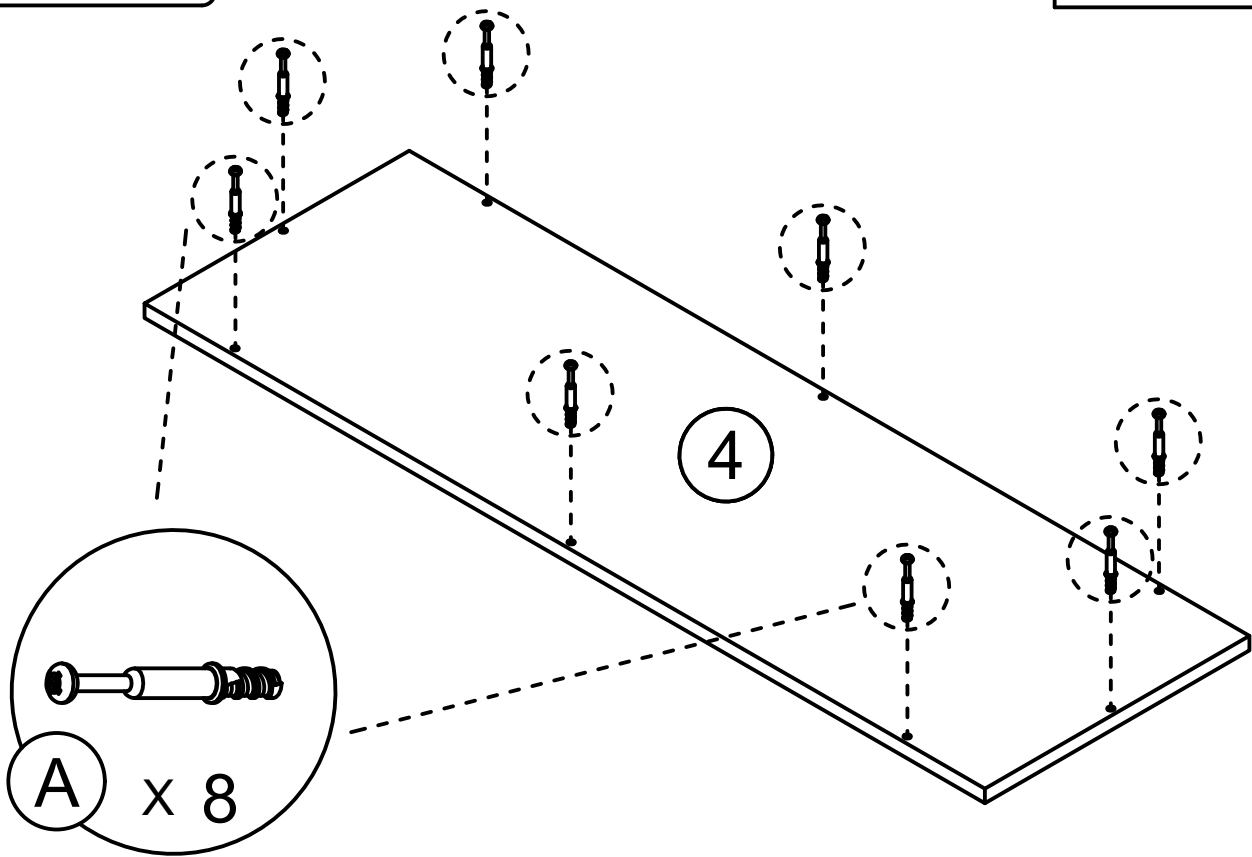
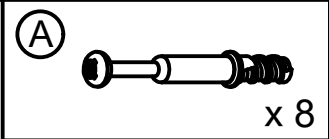

Step 4

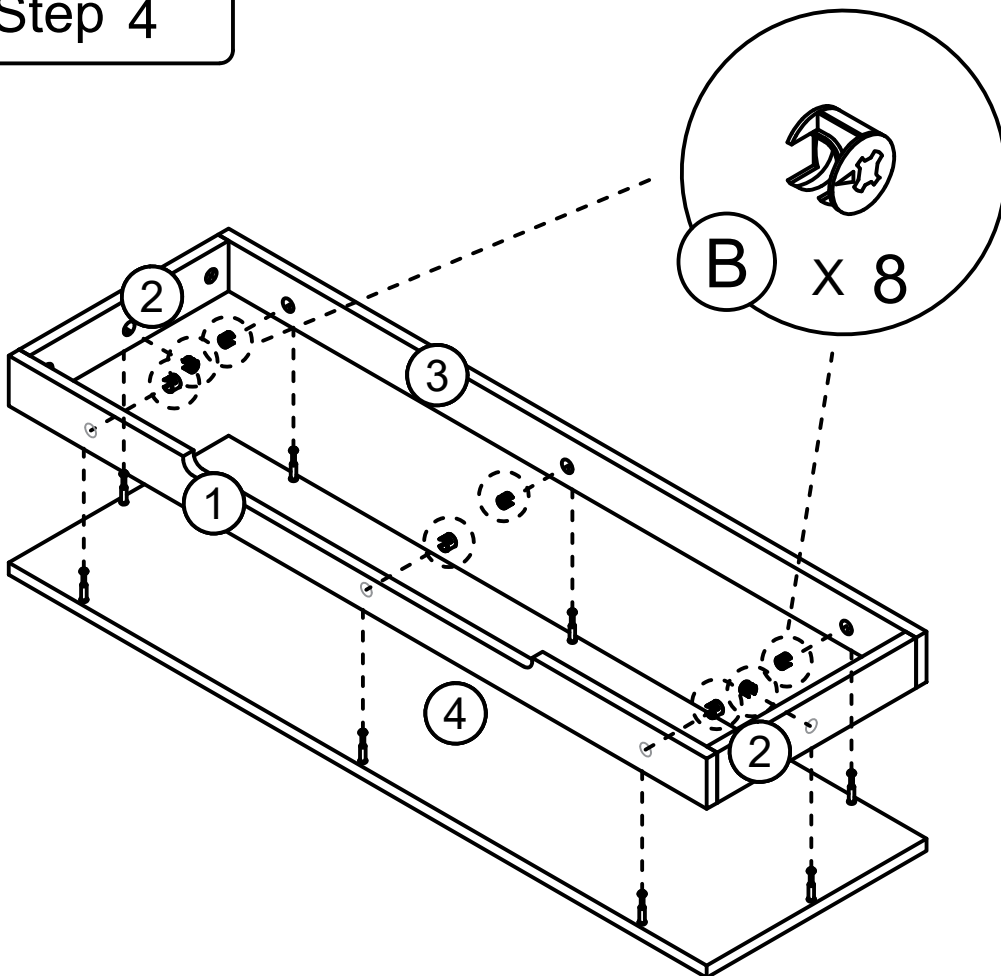

Step 5

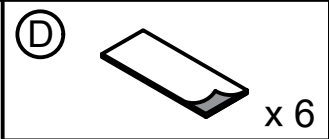

Tear off release paper and stick the black foot pad on the board

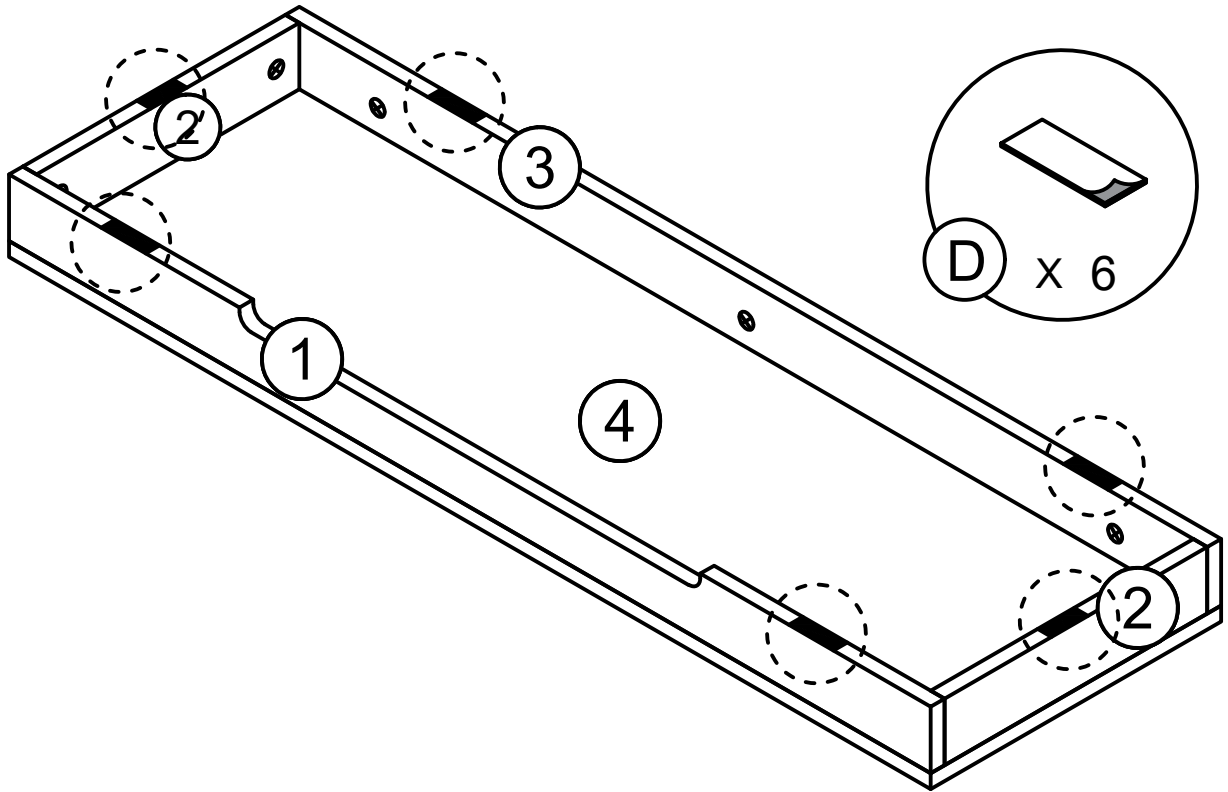

Step 6

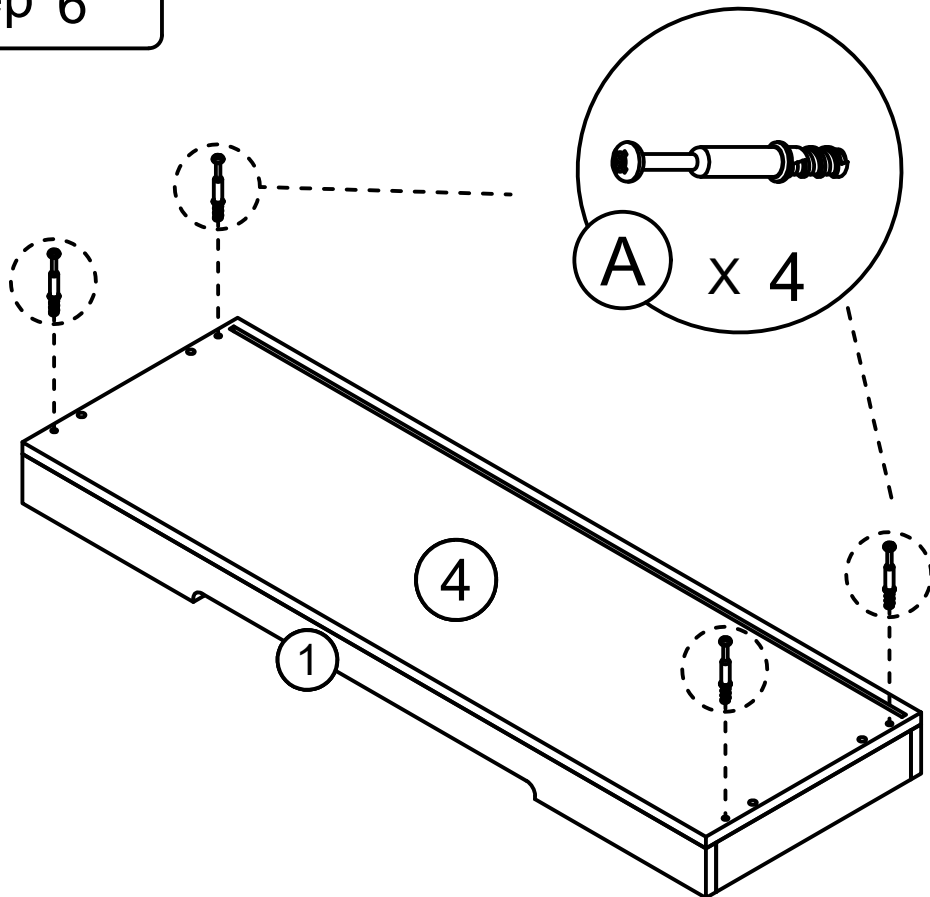
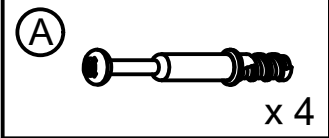

Step 7

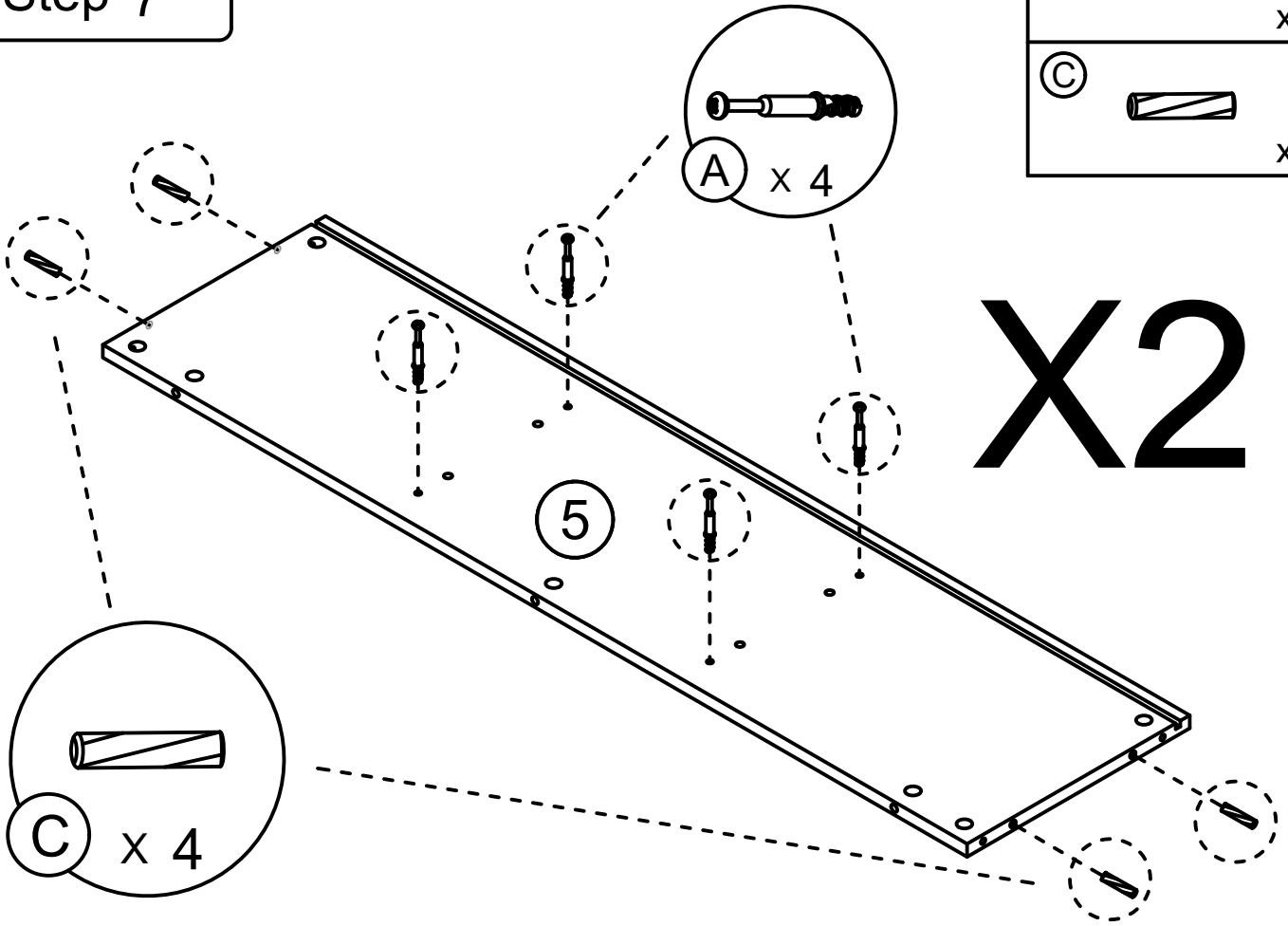
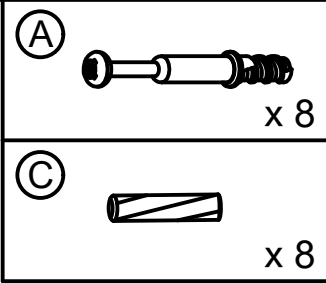

Step 8

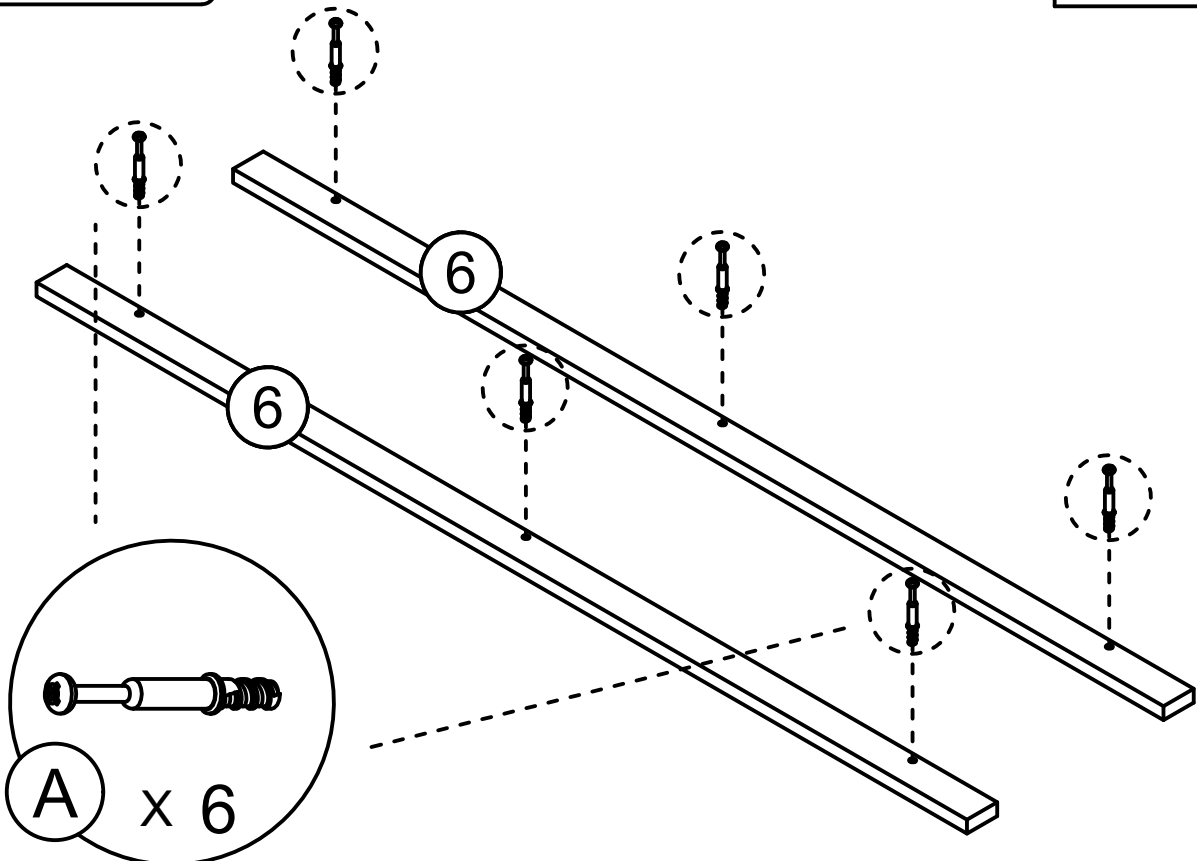
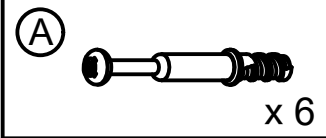

Step 9

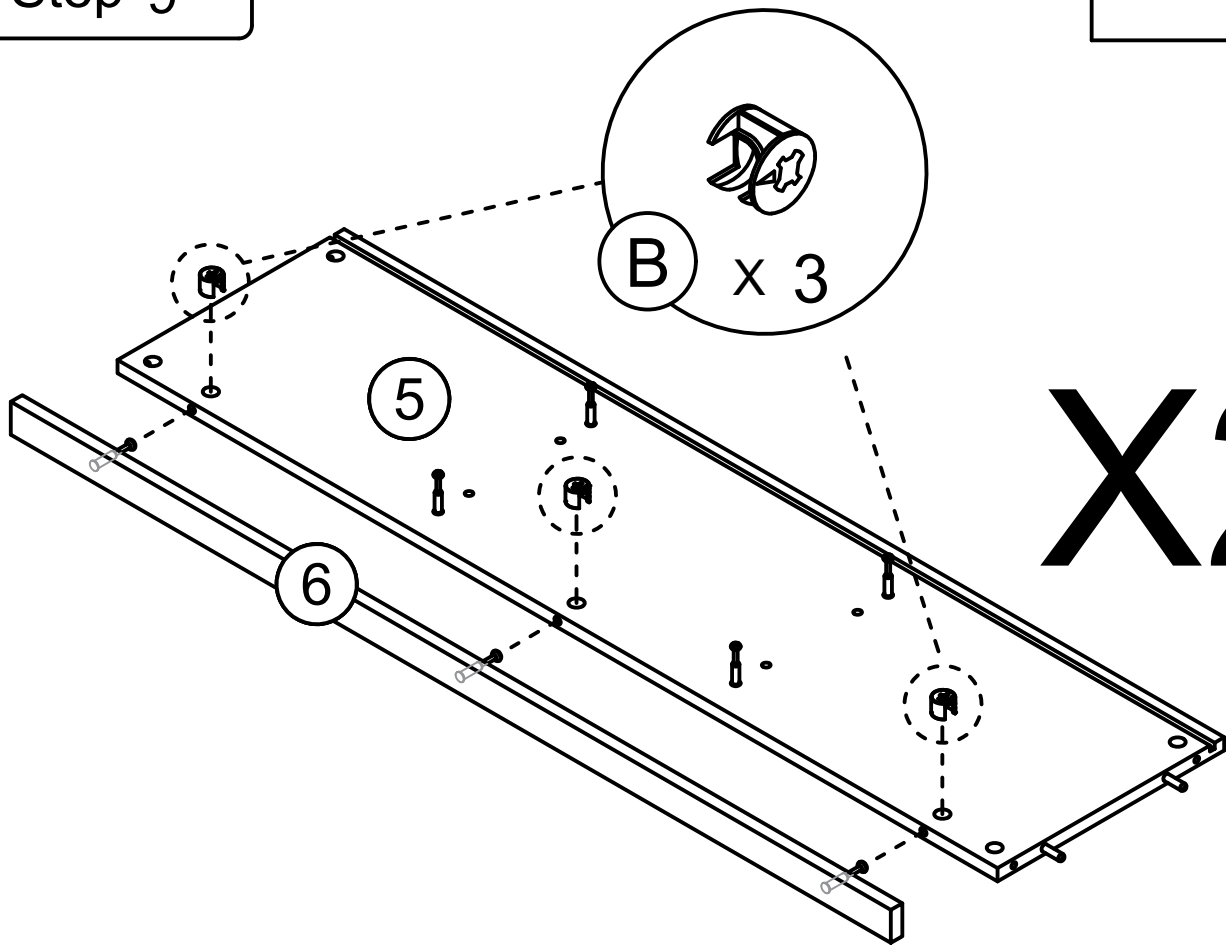

B x 3

X2

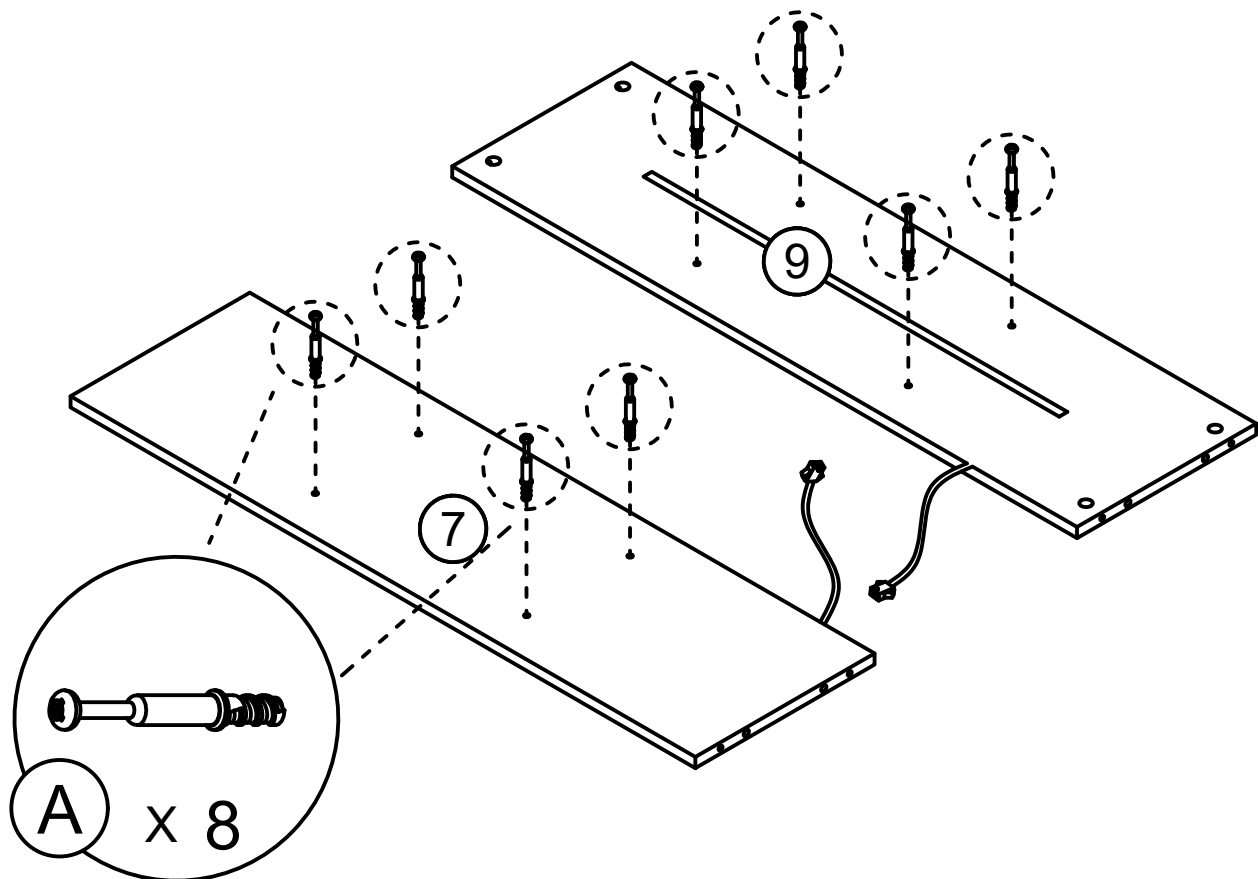
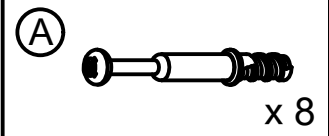

Step 10



A x 8



8

Step 11

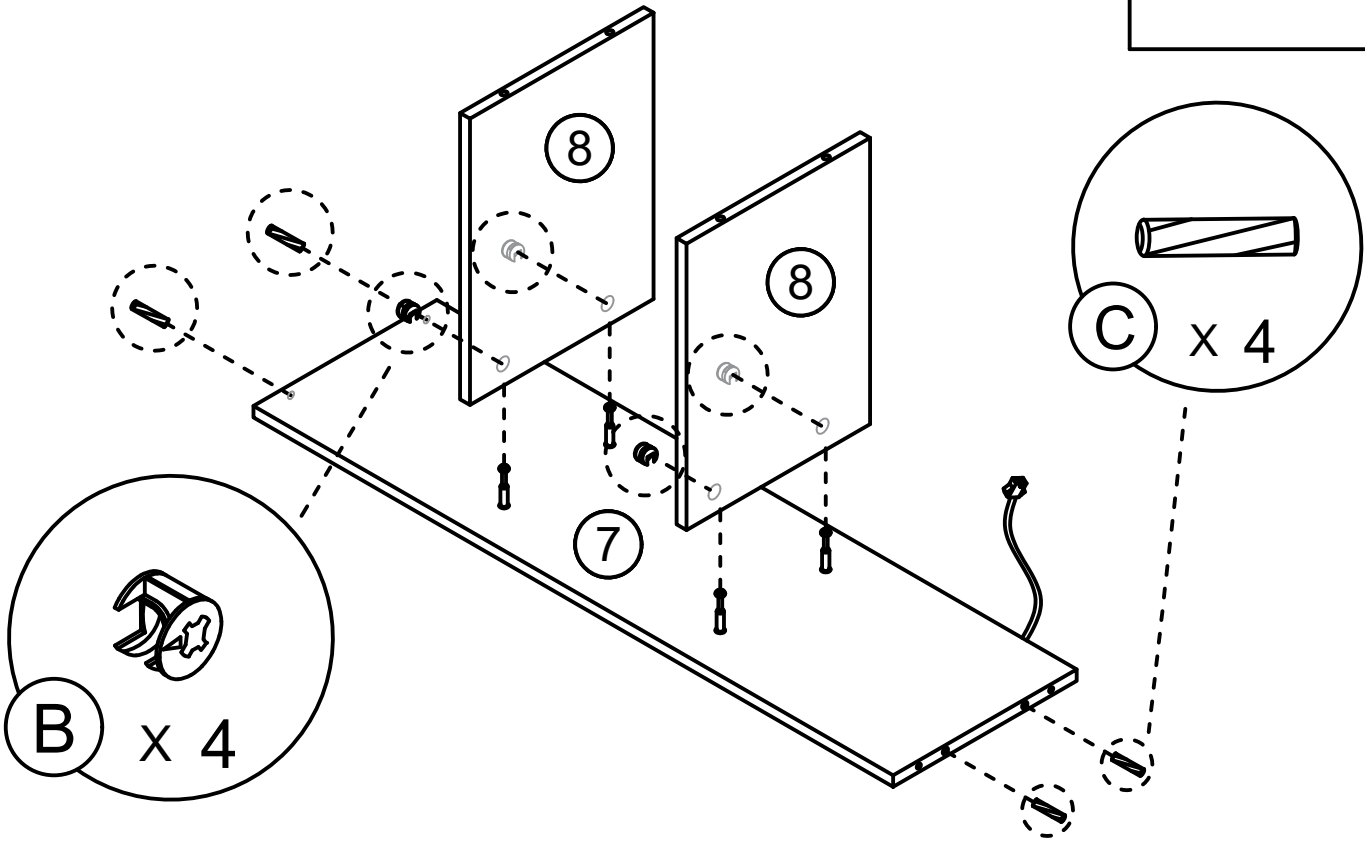
- (B)  x 4
- (C)  x 4



Step 12

- (B)  x 4
- (C)  x 4

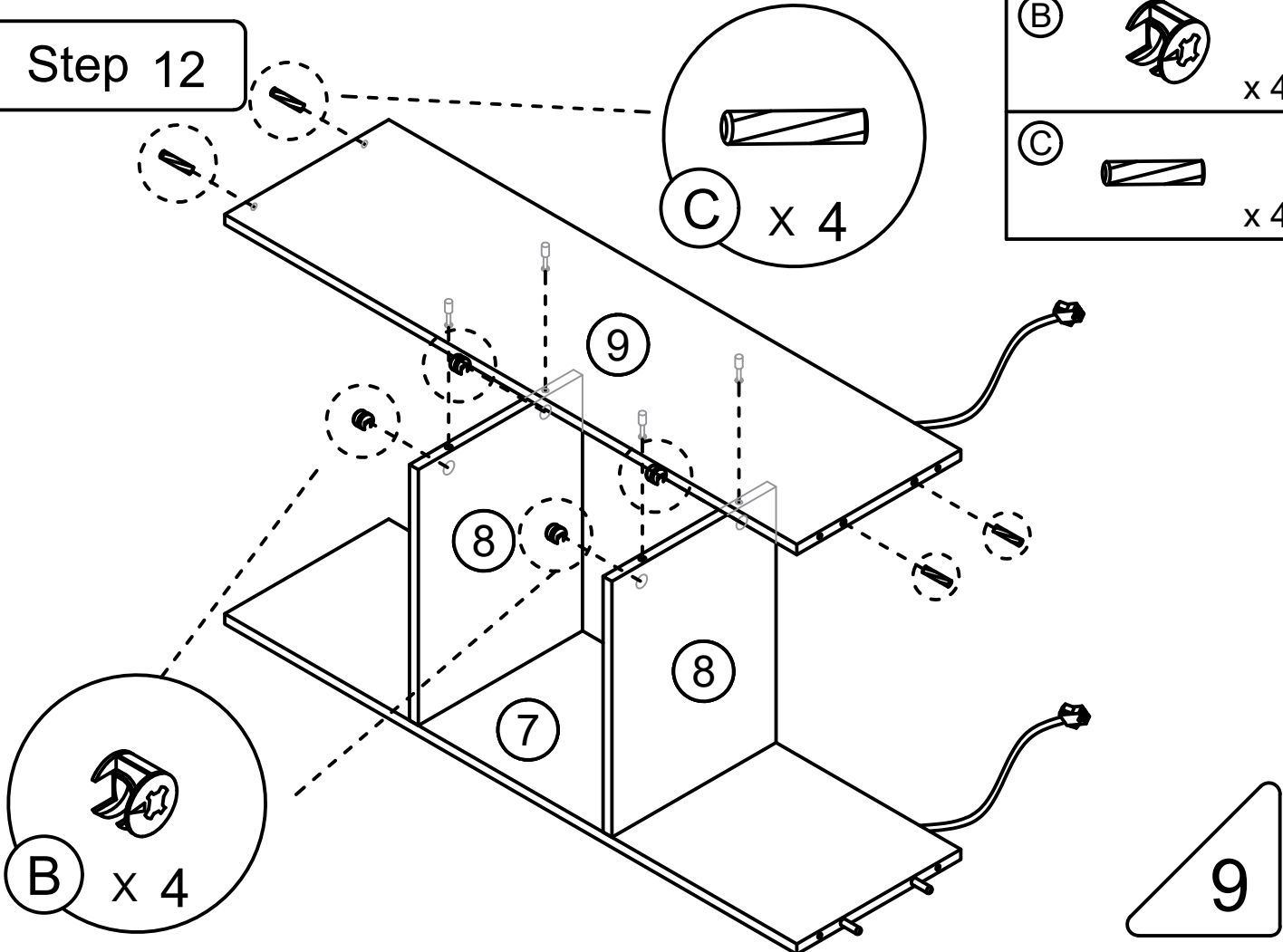

Step 13

(B)  x 4

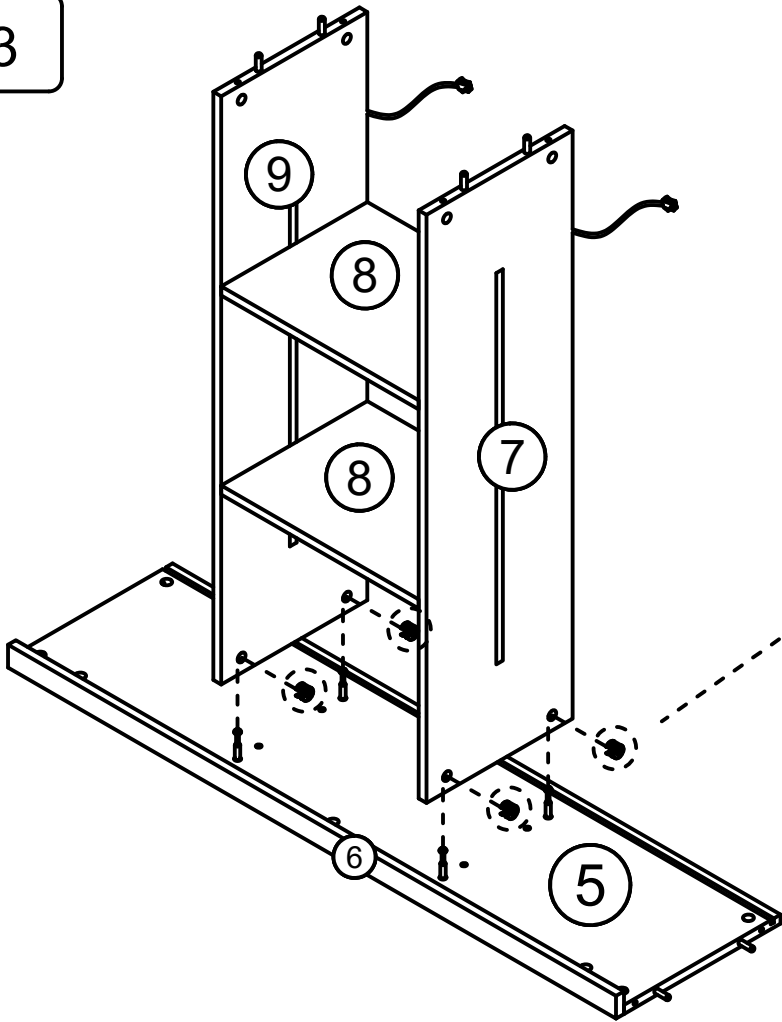

(B)  x 4

Step 14

(B)  x 4

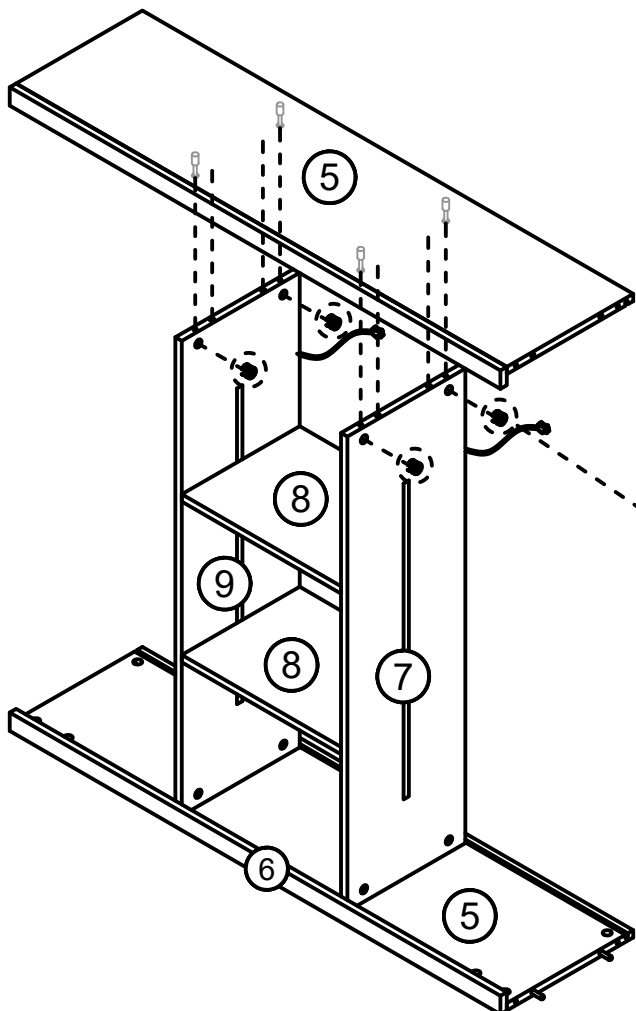

(B)  x 4

Step 15

Ⓑ  x 4

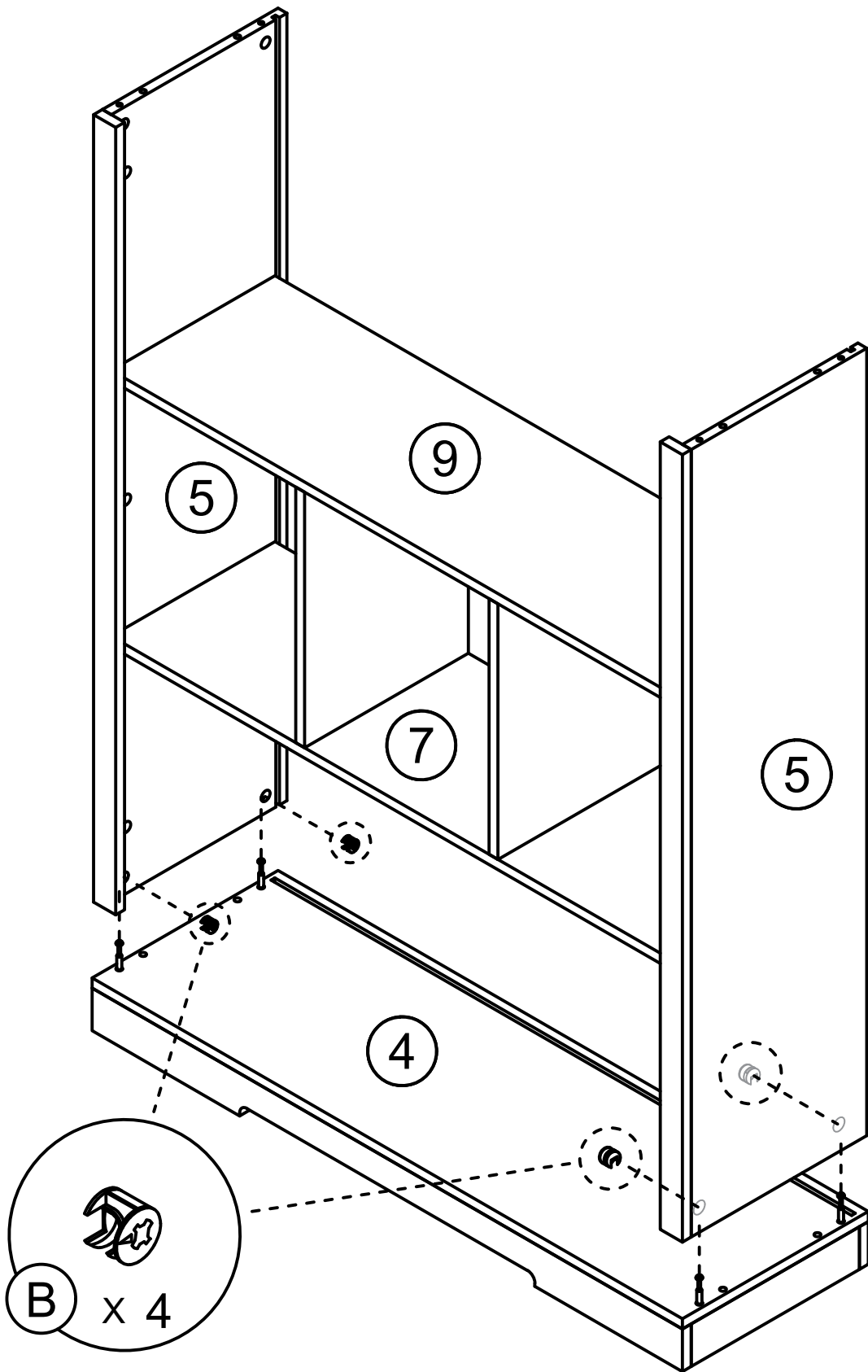

Step 16

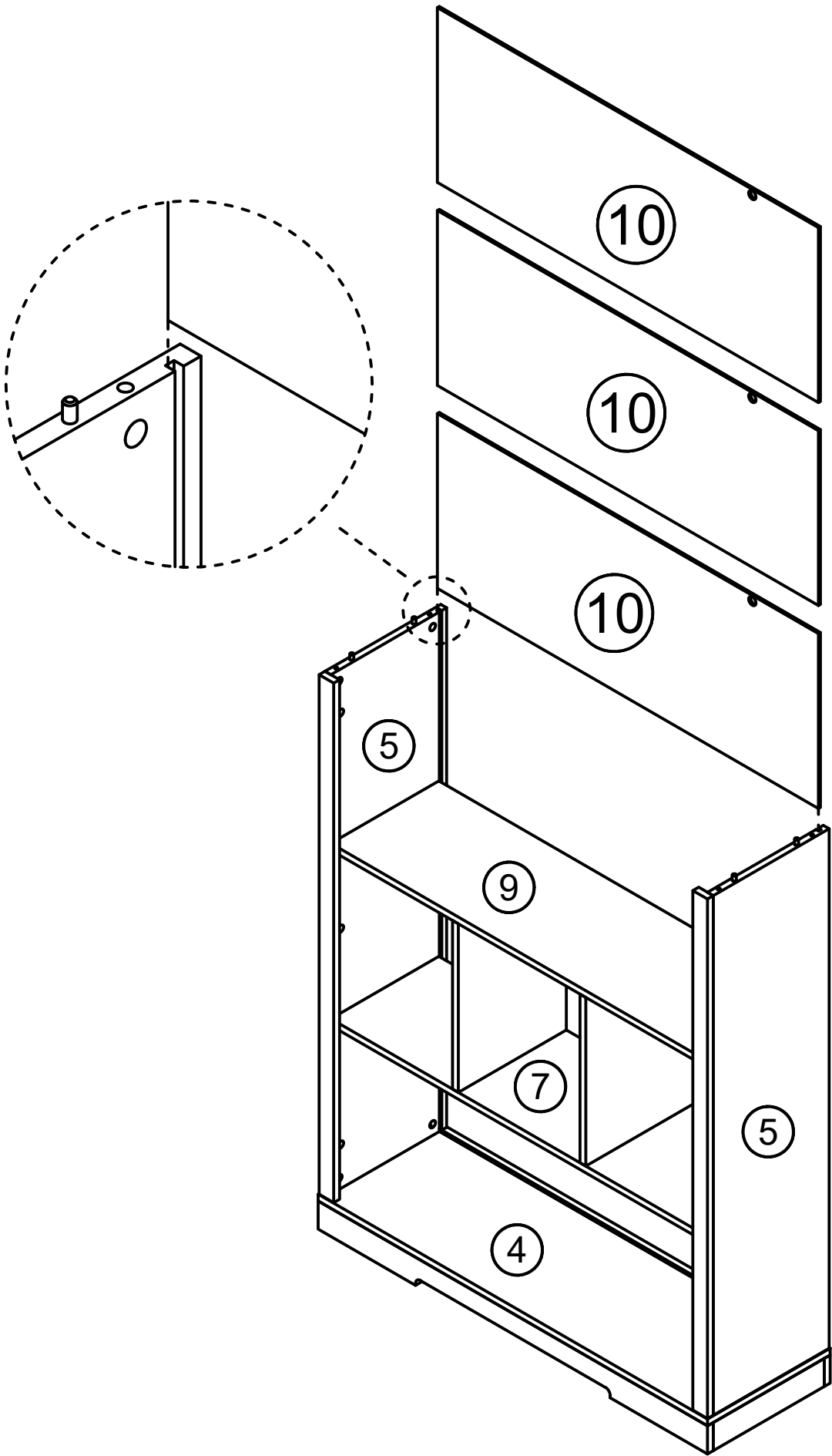

Step 17

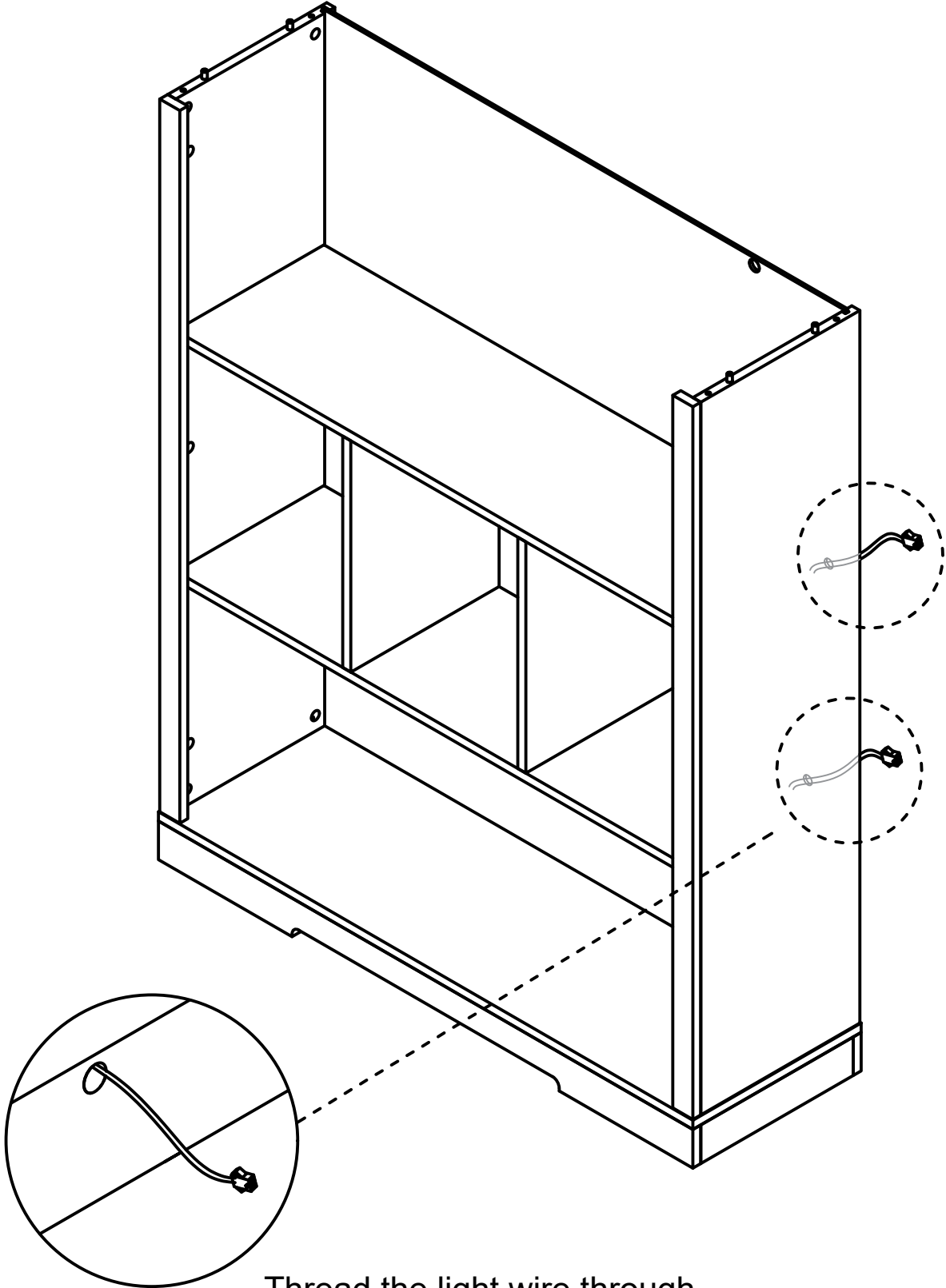

Thread the light wire through
the back panel hole

Step 18

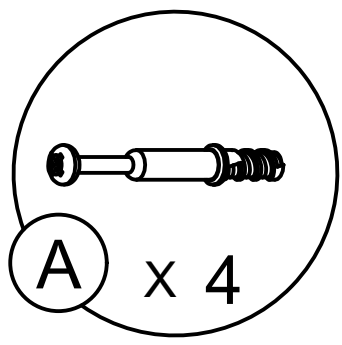
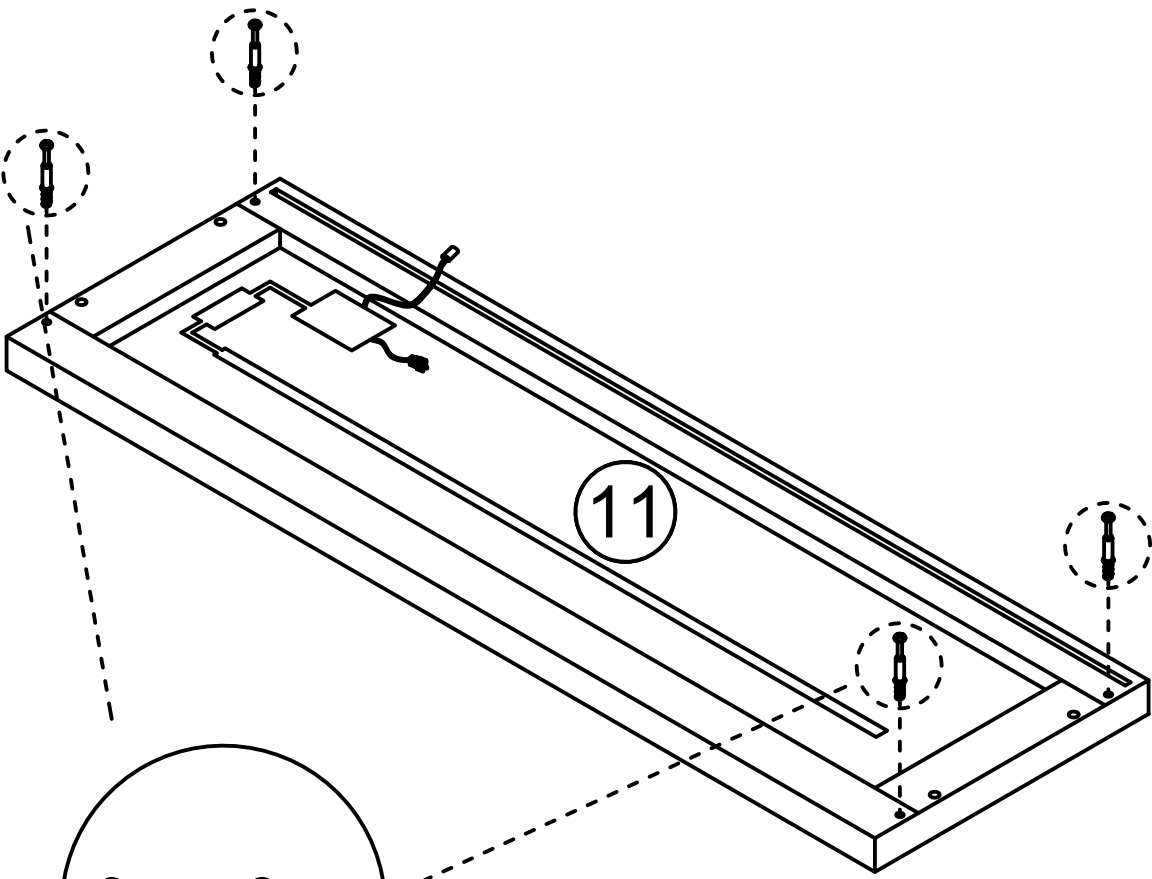
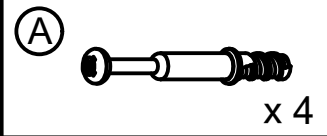

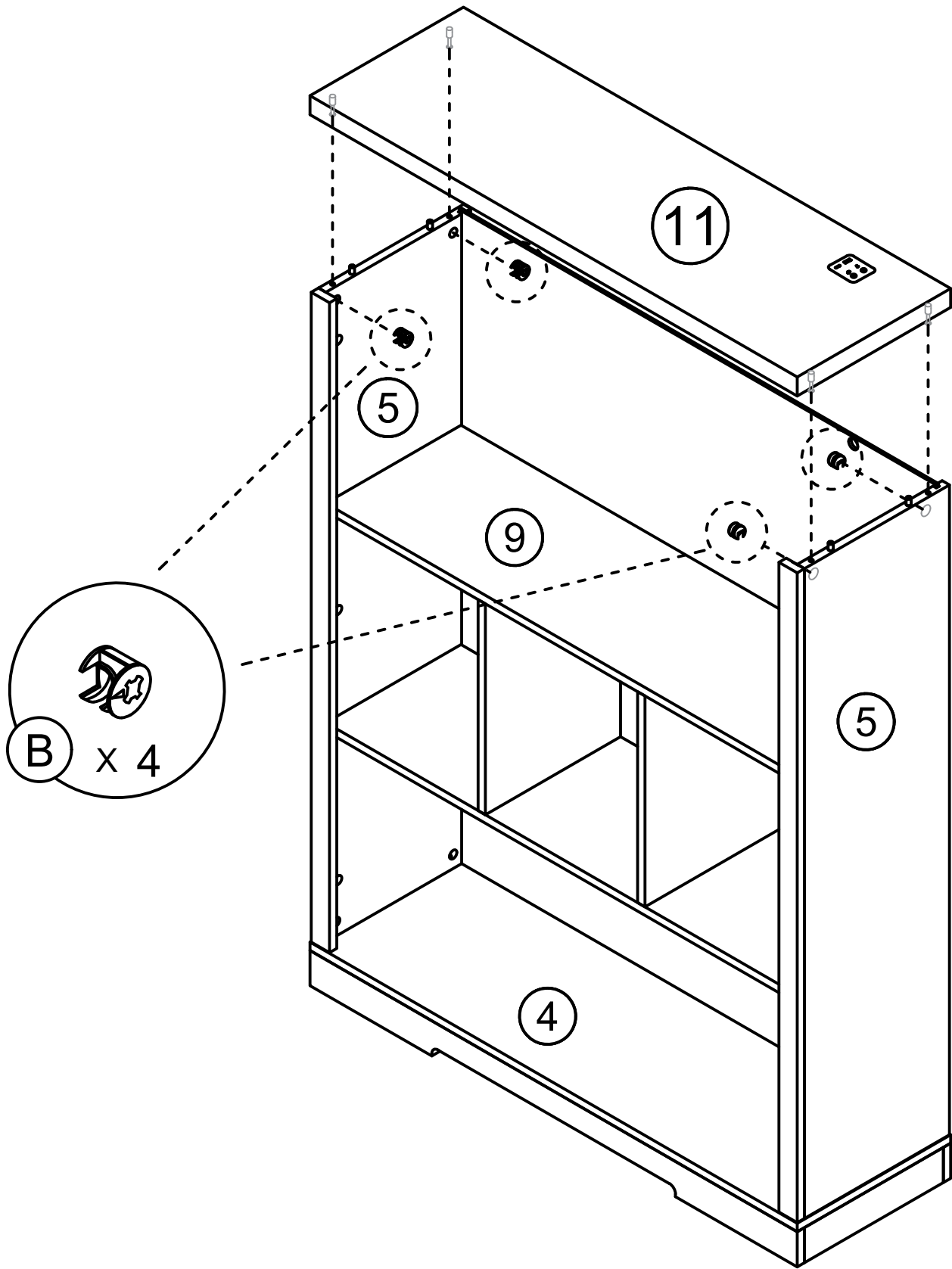

Step 19



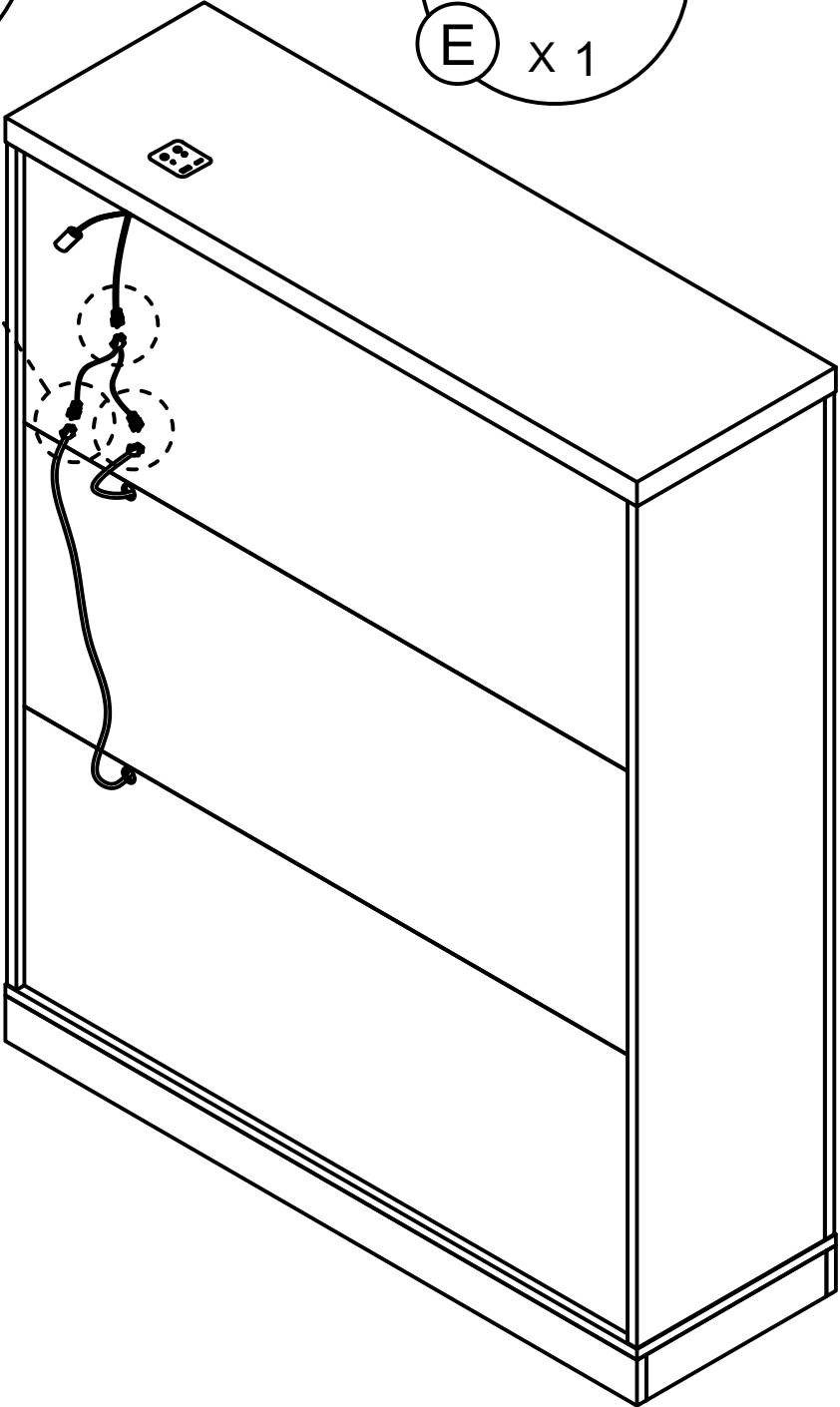
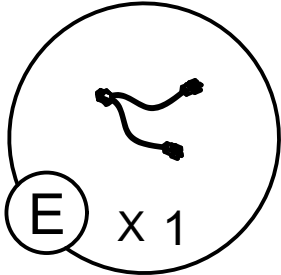
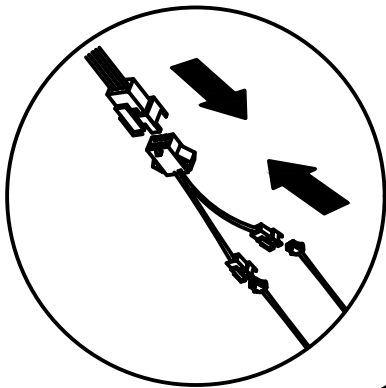
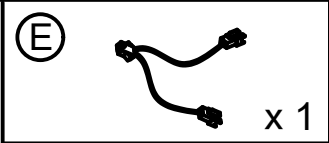

Step 20



Step 21

(F)  x10  x10

(F)  x10  x10



Step 22

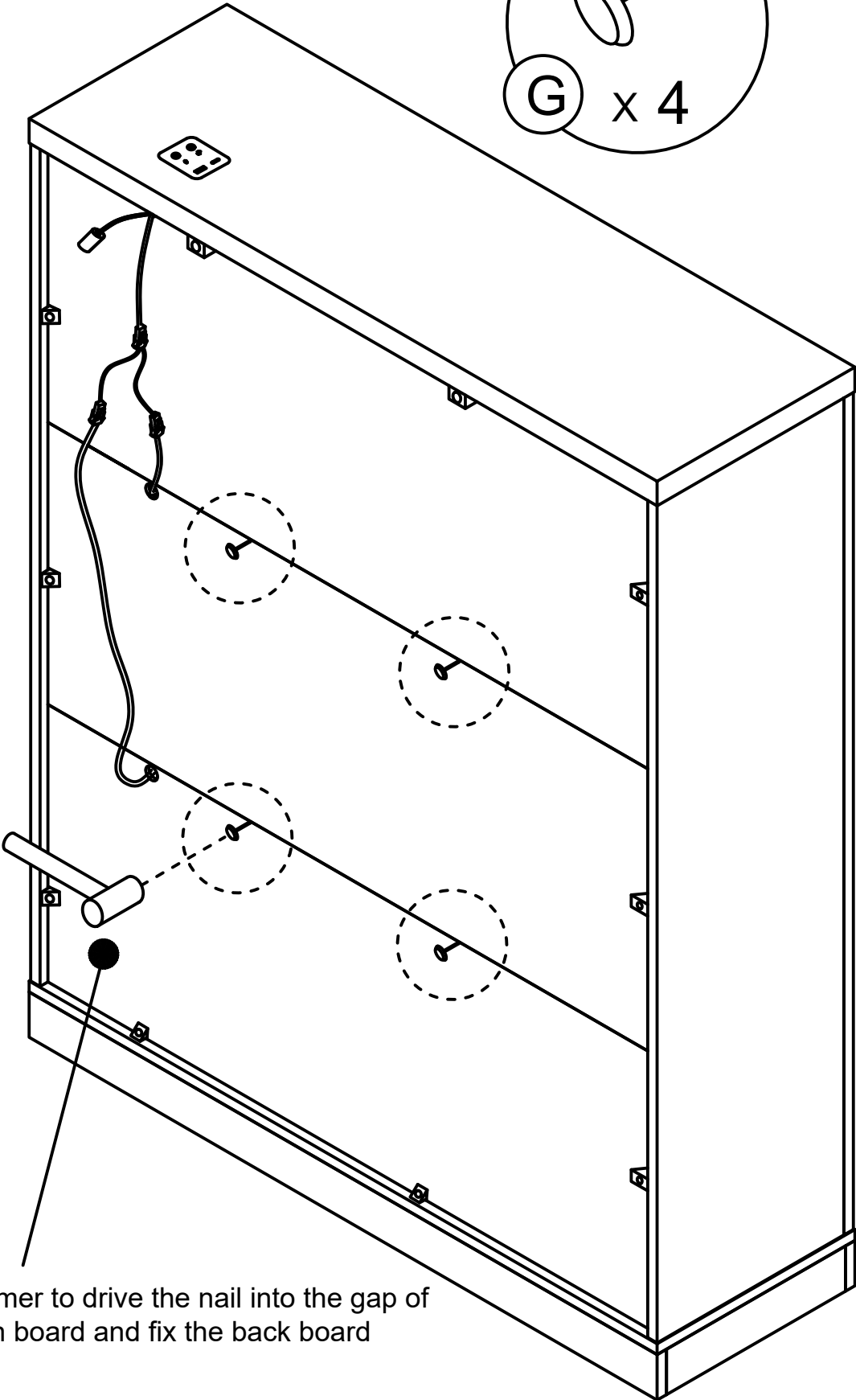
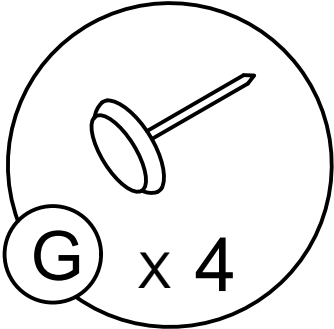
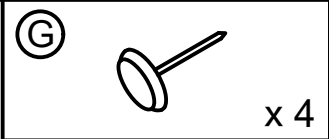

Use a hammer to drive the nail into the gap of the wooden board and fix the back board

Step 23

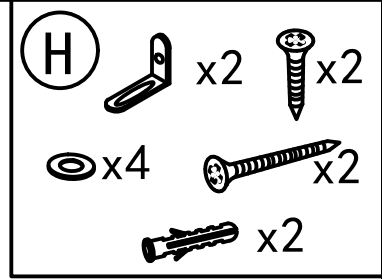
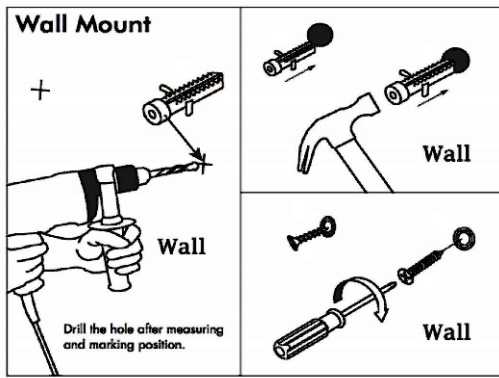
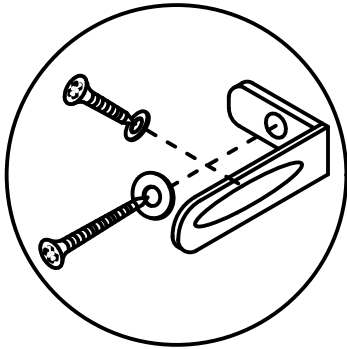

Install as required

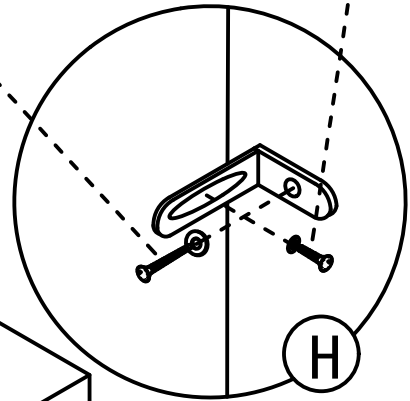
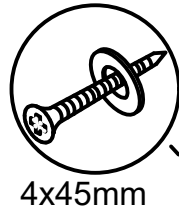
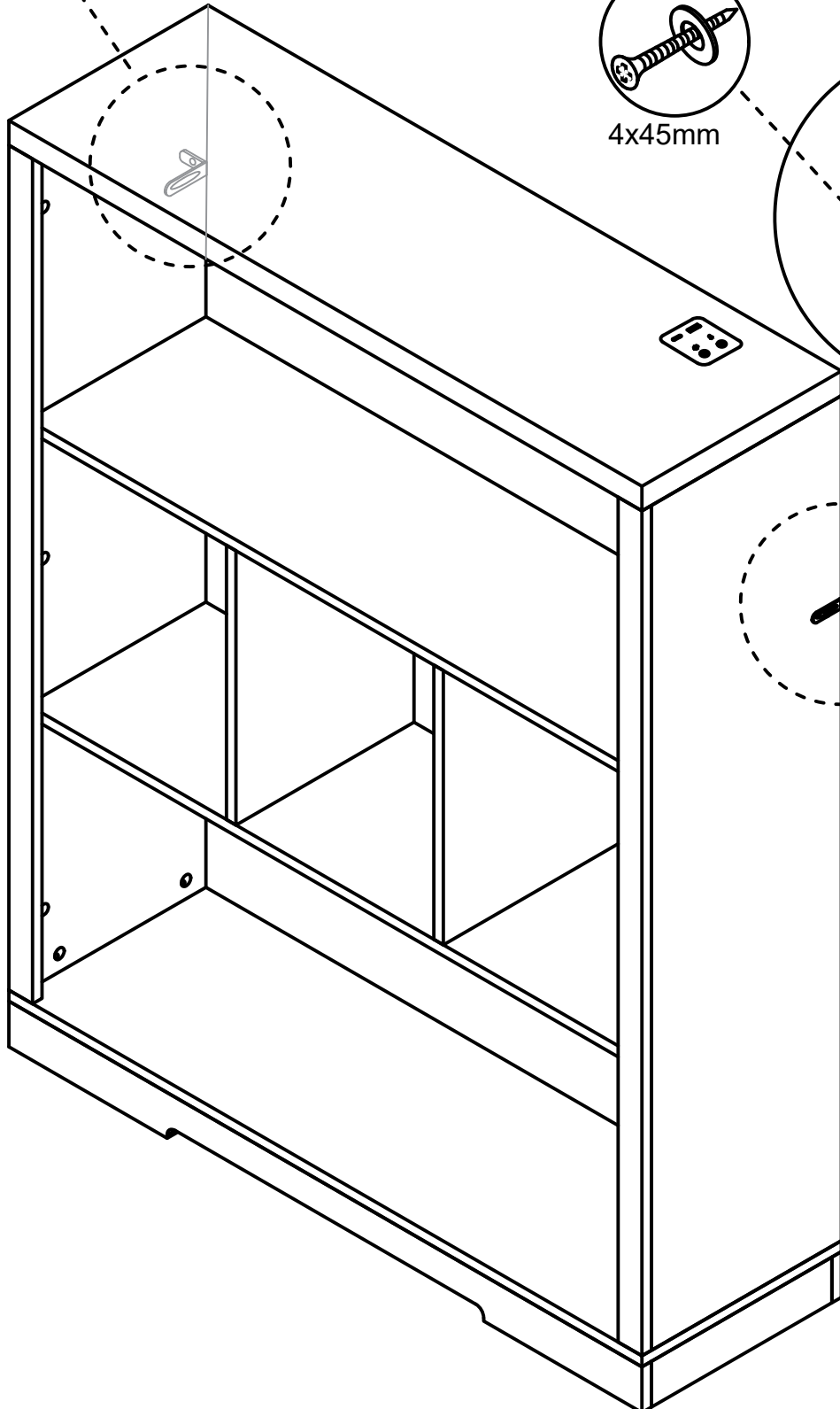

Step 24

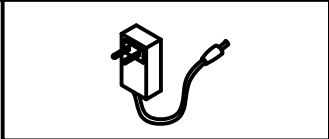

wall

