

Instruction Manual

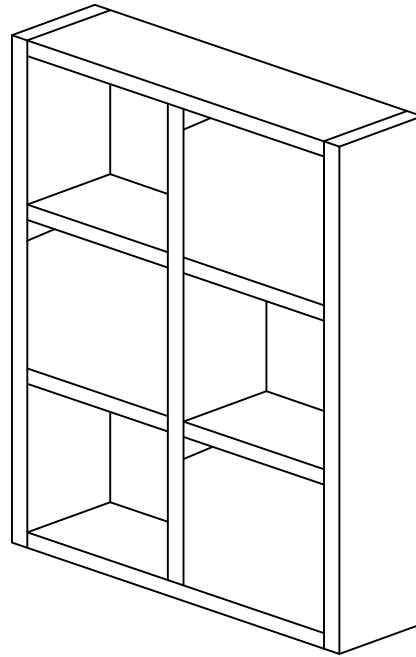

DEAR CUSTOMER,
Thank you for choosing our product. Please read this manual carefully before assembling. If the product is passed on to the third party, this manual has to be passed on along with the product. Enjoy your new purchase!

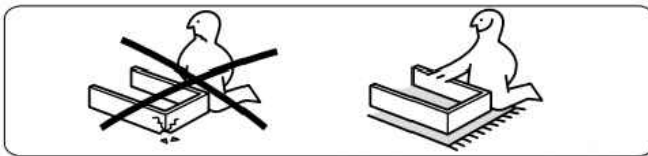



Assemble Item On a Clean Flat Surface

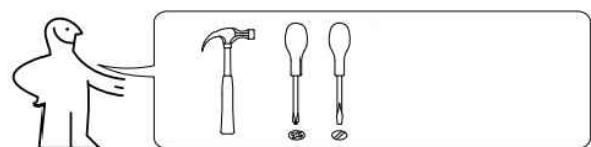

Tools Required For Assembly





HARDWARE LIST

1		2		3		4		5		6
	x8pcs		x8pcs		x20pcs		x9pcs		x30pcs	

PARTS LIST

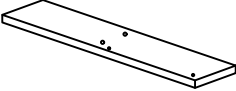
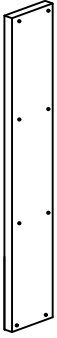
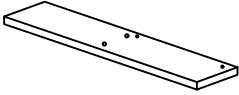

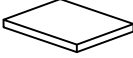
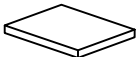
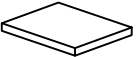
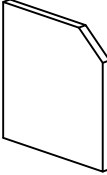
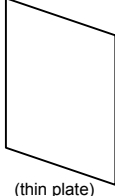
Note: there will be some error in the measurement, the actual size shall prevail.

<p>A</p>  <p style="text-align: right;">×1pc</p>	<p>B</p>  <p style="text-align: right;">×2pcs</p>	<p>C</p>  <p style="text-align: right;">×1pc</p>
<p>D</p>  <p style="text-align: right;">×1pc</p>	<p>E</p>  <p style="text-align: right;">×1pc</p>	<p>F</p>  <p style="text-align: right;">×1pc</p>
<p>G</p>  <p style="text-align: right;">×1pc</p>	<p>H</p>  <p style="text-align: right;">×1pc</p>	<p>I</p>  <p style="text-align: right;">×3pcs</p>
		<p>J</p>  <p style="text-align: right;">(thin plate) ×3pcs</p>

NOTE

- Please check that you have all the parts and hardware listed before assembling.
- Please do not tighten all bolts until the table is assembled completely.
- If you find that something is missing, please contact the store you purchase immediately.
- At least every 4 months, check all bolts, screws and knobs to be sure they are tight.

Screws Installation Steps

- | | |
|---|---|
| 1  ×20pcs | 2  ×20pcs |
|---|---|

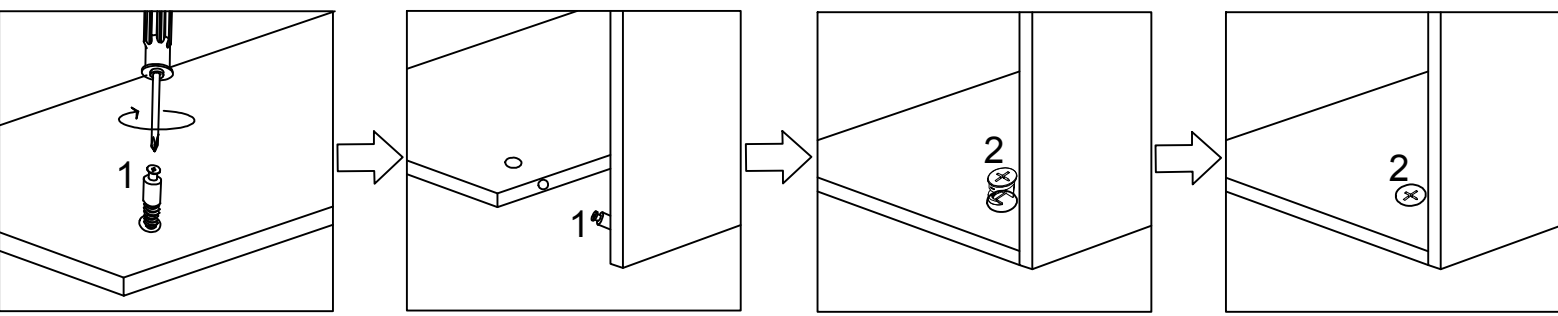

Screw the eccentric screw onto the board. Find the corresponding board to insert. Insert eccentric bolt into round hole. Turn clockwise about 180° to lock the board.

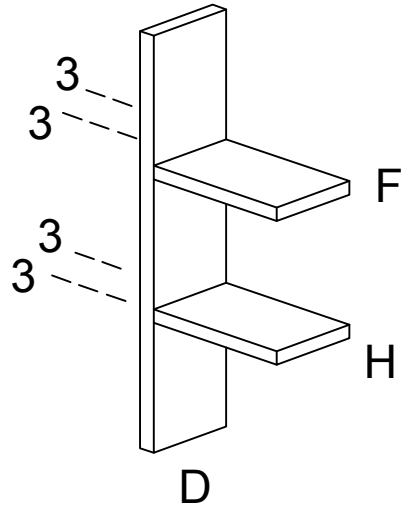

Step:1

- | |
|---|
| 3  ×20pcs |
|---|



Install panel through fitting 3.

Step:2

- | | |
|--|---|
| 1  ×8pcs | 2  ×8pcs |
| | 4  ×9pcs |

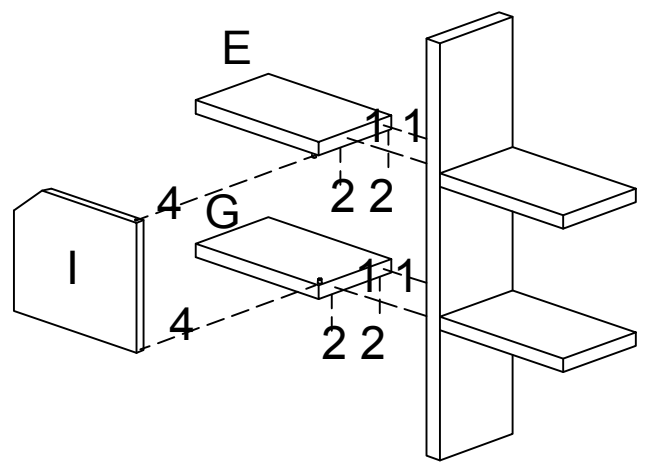

First, I, E and G plates are installed with No. 4 fitting, and assembled with the previous step.

Step:3

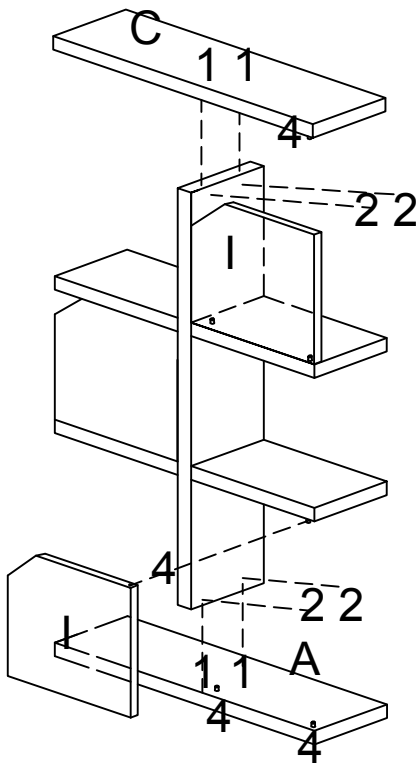
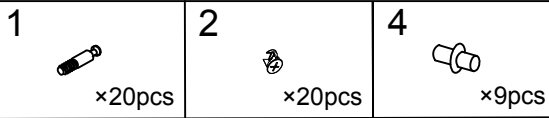

Install panel through fitting 1,2 and 4.

Step:4

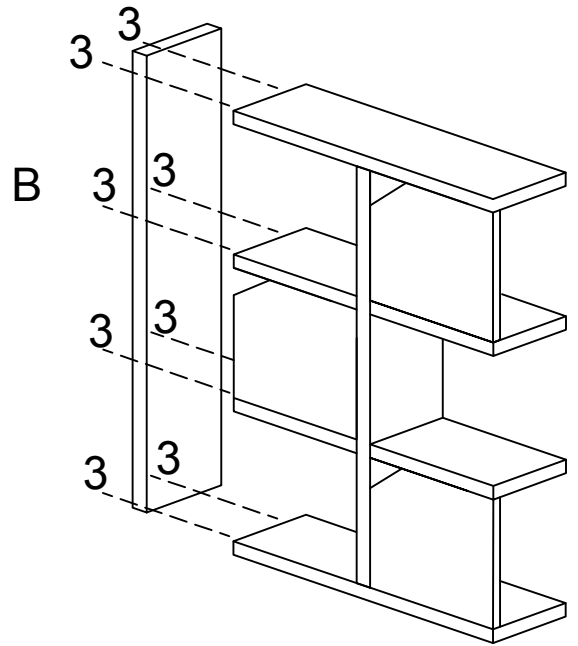
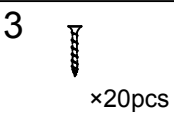

Install panel through fitting 3

Step:5

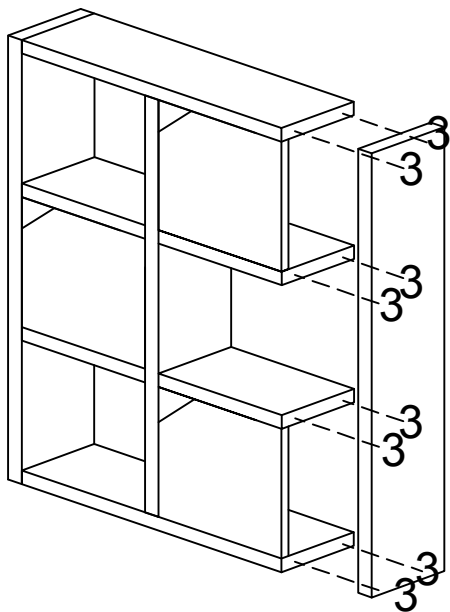
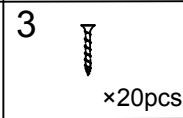

Install panel through fitting 3.

Step:6

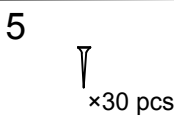

Installation Complete !

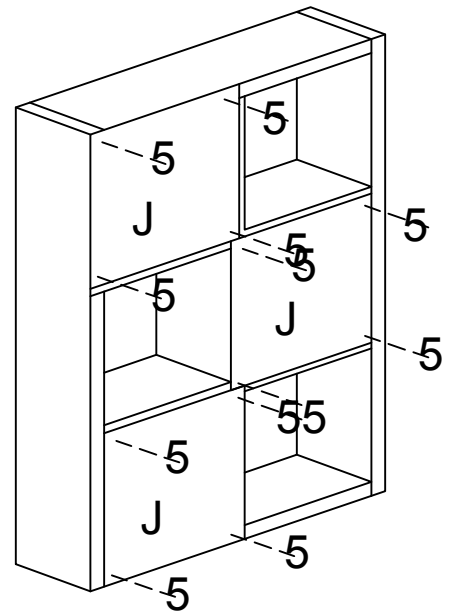

Install back panel through fitting 5