

# ASSEMBLY INSTRUCTIONS

---

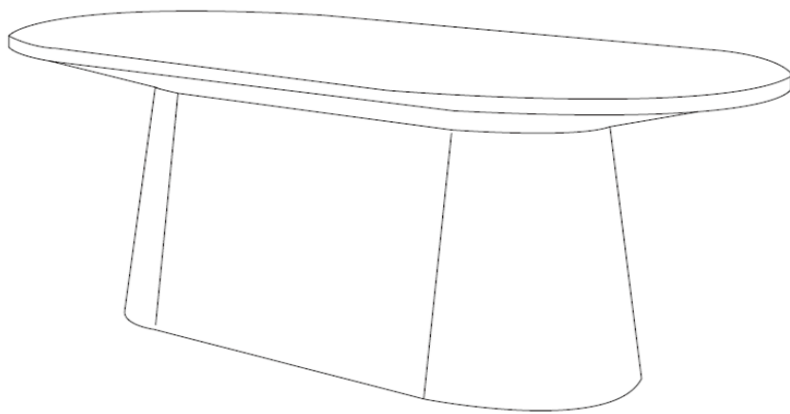

## TOOLS REQUIRED



Screwdriver  
( Not included)



(Included)  
Allen Wrench



2 - People

## ASSEMBLY RATING



EASY ← → DIFFICULT

The Assembly Rating is a 5-point system showing the level of effort needed to assemble a specific product.

VERSION #25-12-05

---



## **CHECK BEFORE STARTING**

**Are you missing anything?**

Double-check all parts, hardware and accessories listed are all accounted for.

**Check out our Quick Tips!**

We recommend reviewing the pre-assembly handouts. Even experts need a refresher now and then!

**Should we send any replacements?**

Are there any irregularities or flaws in the parts? We can send replacements!

**Prep Time!**

Please review the assembly instructions and all diagrams prior to assembling.

# PRE ASSEMBLY INTRODUCTION

We understand building ready-to-assemble furniture can be a challenging experience for some. To help avoid confusion, we have provided some helpful tips that may speed up the process.



## Teamwork

ALWAYS have at least two people to help with transporting and assembling the product to avoid potential injury and/or damage.



## Suitable Location

Assembling near the area of the intended location is highly recommended.



## Sufficient Space

Make sure you have enough space to move around during the assembly.



## Avoid Scratches

Use cardboard, blankets or a carpeted area while assembling furniture to prevent scratches and damages.



## Flat Surface

Make sure the furniture rests on a flat and level surface with each leg evenly touching the floor.

# ASSEMBLY AND CARE ADVICE



FAILURE TO FOLLOW THE GUIDELINES BELOW MAY RESULT IN INJURY AND/OR PROPERTY DAMAGE.



Position each part correctly and insert screws or bolts into their respective holes.

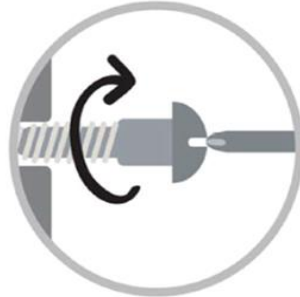

Turn clockwise to tighten and only tighten when step is completed or when instructed to do so.



Use the appropriate hand tools or power tools for assembly. Select steps, such as tightening screws and/or bolts, may require hand tools to avoid causing damage during assembly.



Save the instructions and store any supplied tools for later maintenance.



After two weeks, check and tighten any loose hardware and repeat again every six months thereafter.

**IT IS THE USER'S RESPONSIBILITY TO MAINTAIN THE FURNITURE. THE HARDWARE MAY LOOSEN OVER TIME AND MAY CAUSE THE FURNITURE TO BE WOBBLY AND UNABLE TO SUPPORT ITS INTENDED WEIGHT CAPACITY. THIS MAY LEAD TO COLLAPSE AND MAY CAUSE SERIOUS INJURY.**

# OVAL DINING TABLE



- Please keep instructions for future reference.
- Check the quantity and irregularity of parts and hardware before you start.

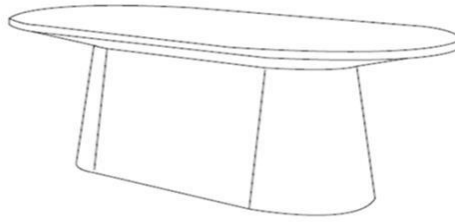

## PARTS

(P1) - 1PC



TABLE TOP

(P2) - 1PC

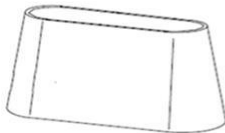

PEDESTAL LEG

(P3) - 1PC

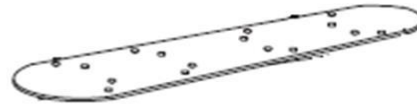

MOUNTING PANEL

## HARDWARE

(H1) - 16 PCS



M6 X 35MM JCBC SCREW

(H2) - 16 PCS



SPRING WASHER

(H3) - 8 PCS



FLAT WASHER

(H4) - 1 PC



ALLEN KEY

(H5) - 2 PCS



WOOD DOWEL

(H6) - 8 PCS



LEG ADJUSTABLE GLIDE

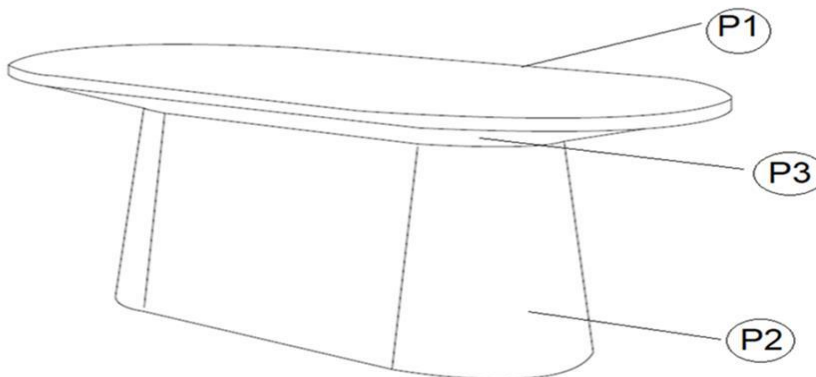

# ASSEMBLY INSTRUCTIONS

## Packed in 2 cartons







Please read instructions carefully

Remove all wrapping materials, staples and packing straps from the carton. Refer to Parts List and Hardware List and ensure they are complete before you start assembling. Place all wooden parts on a clean, flat and soft surface (e.g carpet or rug) to prevent parts from being scratched.

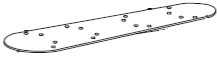
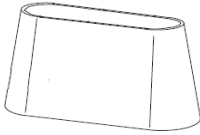
CAUTIONS: 1) DO NOT FULLY TIGHTEN BOLTS AND NUTS UNTIL ALL PARTS HAVE BEEN ASSEMBLED.

2) DO NOT OVER-TIGHTEN BOLTS AND NUTS .

3) KEEP ALL HARDWARE PARTS OUT OF REACH OF CHILDREN.

Carton	Designation	Part List	Hardware List
1	Table Top	 P1 x 1pc	
	Mounting Panel	 P3 x 1pc	
2	Pedestal Leg	 P2 x 1pc	 H1 x 16pc <b>M6x35 JCBC SCREW</b>  H2 x 16pc <b>Spring Washer</b>  H3 x 8pc <b>Flat Washer</b>  H4 x 1pc <b>Allen Key</b>  H5 x 2pc <b>Wood Dowel M8x30mm</b>  H6 x 8pc <b>Legs Adjustable Glide</b>

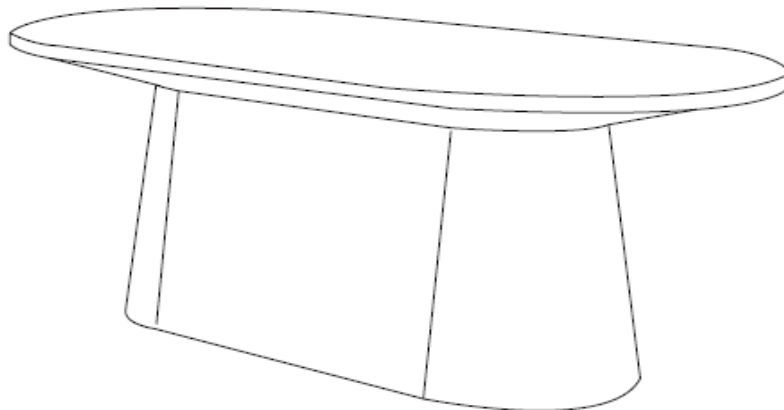







COMPLETE ASSEMBLY

# ASSEMBLY INSTRUCTIONS

## OVAL DINING TABLE

PART LIST		
No	Description	Qty
P1	Table Top	1
P2	PEDESTAL LEG	1
P3	MOUNTING PANEL	1

HARDWARE LIST			
No	Description		Qty
H1	M6 x 35mm JCBC BOLT		16
H2	SPRING WASHER		16
H3	FLAT WASHER		8
H4	ALLEN KEY		1
H5	WOOD DOWEL		2
H6	ADJUSTABLE LEG STUD		8

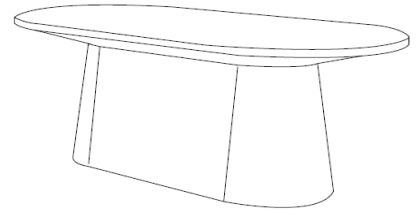

### STEP 1



Detach Mounting Panel (P3) from the Table Top (P1) before assembling the table . Use the Allen Key (H4) to remove the Bolts. Remove the Mounting Panel from its place, put it aside and use the Panel (P3) and the Bolts later to complete the assembly of the table .

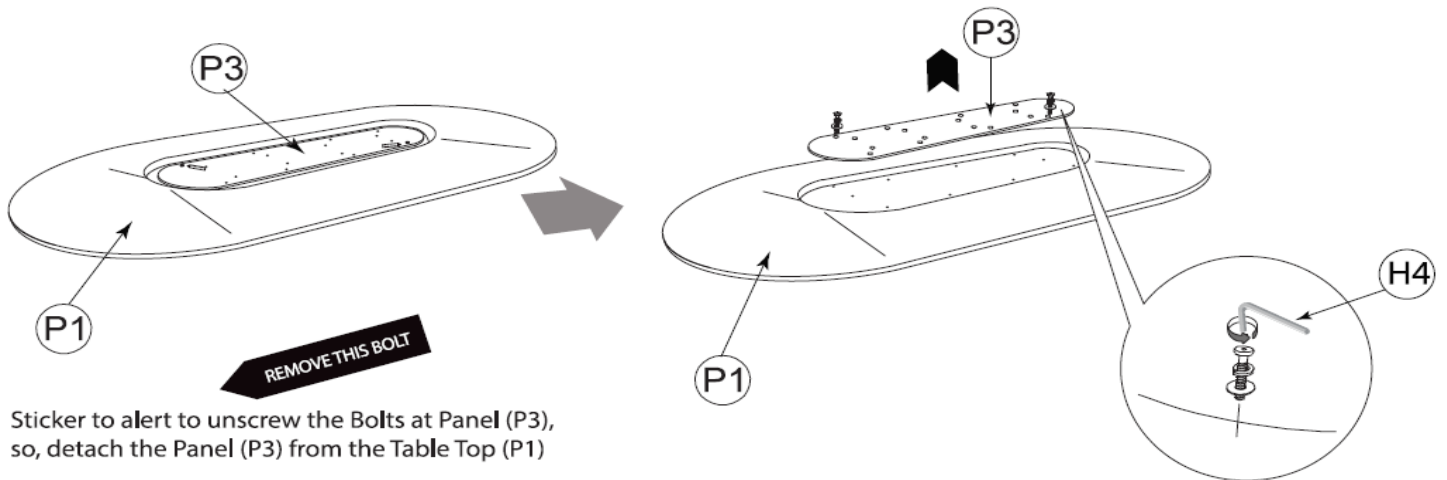

Sticker to alert to unscrew the Bolts at Panel (P3), so, detach the Panel (P3) from the Table Top (P1)

### STEP 2

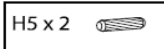

Install the wooden dowels (H5) into the holes . Use a mallet to snug the dowels .

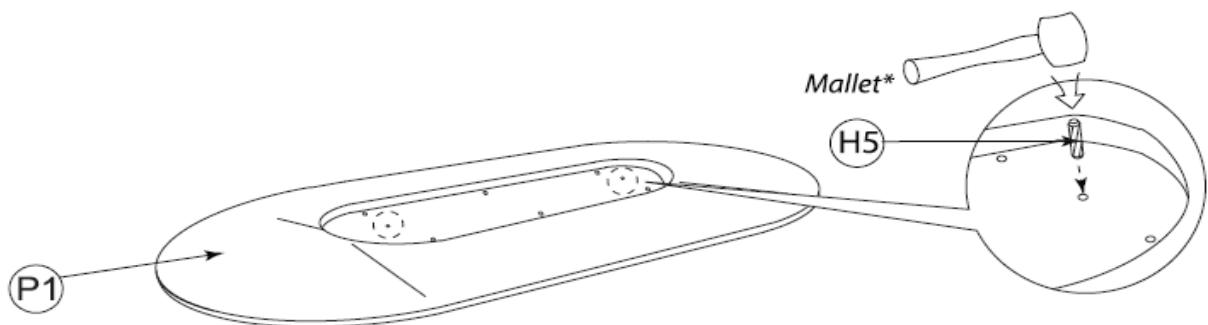



# ASSEMBLY INSTRUCTIONS

## OVAL DINING TABLE

### STEP 3



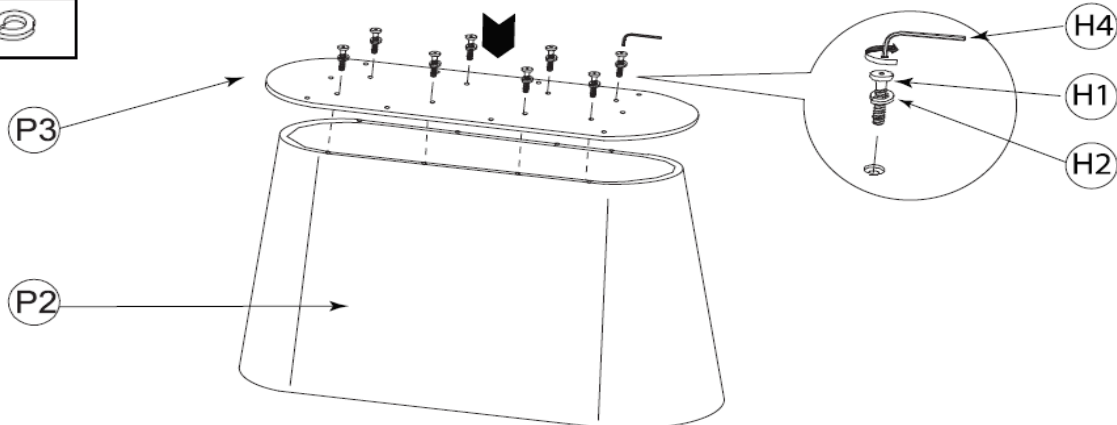

Attach the Mounting Panel (P3) to the Table Pedestal Leg (P2) as shown. Align the Bolt (H1) fitted with the Spring Washer (H2). Tighten the Bolts using the Allen Key (H4).

H1 x 8	
M6 x 35mm	
H2 x 8	



### STEP 4

Attach the Table Leg to the Table Top (P1) by aligning holes in the Mounting Panel (P3) to meet the Wooden Dowels in the Table Top. Push the Leg until it is well snug to the Table Top. Fit the parts by aligning the Bolt (H1) fitted with the Spring Washer (H2) and the Flat Washer (H3). Tighten the Bolts using the Allen Key (H4).

H1 x 8	
M6 x 35mm	
H2 x 8	
H3 x 8	
H6 x 8	

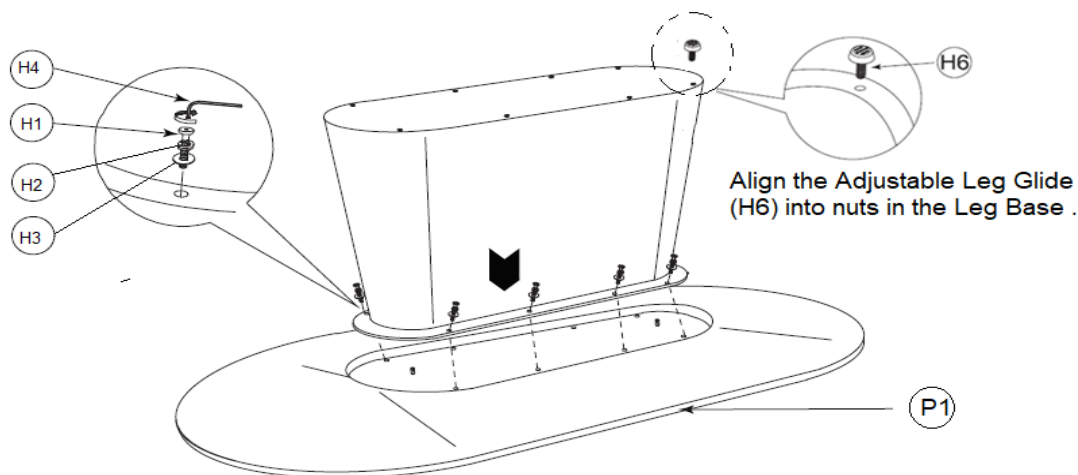

**CAUTION !**  
AFTER FINISHED ASSEMBLY, CAREFULLY  
TURN THE TABLE UPRIGHT WITH THE HELP  
OF TWO ADULTS PEOPLE

**ADJUST THE LEVELERS TO LEVEL THE TABLE**

### CARE AND MAINTENANCE

**SAFETY** - To avoid any risk of suffocation to children or animals, dispose off the plastic bags immediately.

**CLEANING** - Clean with damp cloth and mild detergent. Do not use bleach or abrasive products.

**FITTINGS** - Tighten bolts and nuts from time to time to ensure all parts of product are securely fitted.

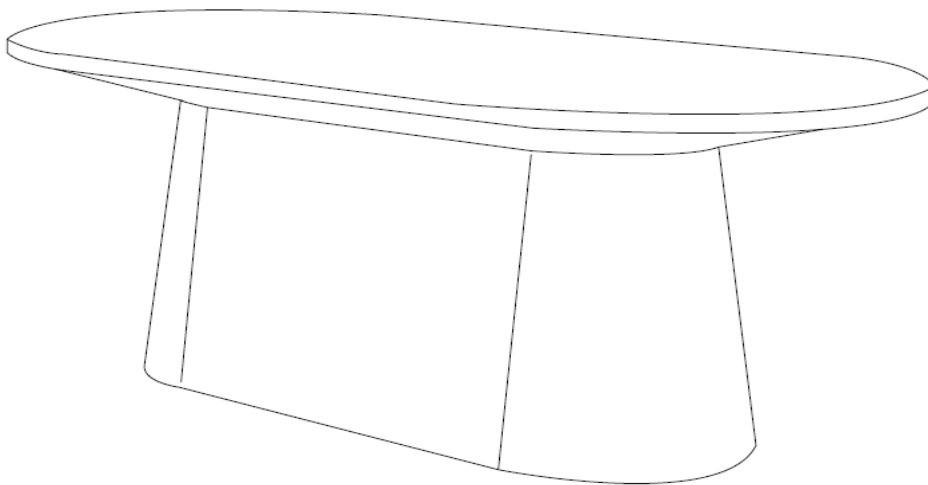

## ASSEMBLY COMPLETED



Please ensure the furniture rests on an even and flat surface. If the product wobbles or feels loose, double-check all bolts and/or screws are properly tightened and secured.



### Keep this handy!

Please retain this instruction manual and any order-related information for future reference.



### Lift, don't drag!

To avoid damage to product please always LIFT the product when transporting or adjusting the placement.

**This product is intended for RESIDENTIAL USE ONLY and not for commercial use .**

#### CARE AND MAINTENANCE

**SAFETY** - To avoid any risk of suffocation to children or animals, dispose off the plastic bags immediately.

**CLEANING** - Clean with damp cloth and mild detergent. Do not use bleach or abrasive products.

**FITTINGS** - Tighten bolts and nuts from time to time to ensure all parts of product are securely fitted.

# ASSEMBLY INSTRUCTIONS

---

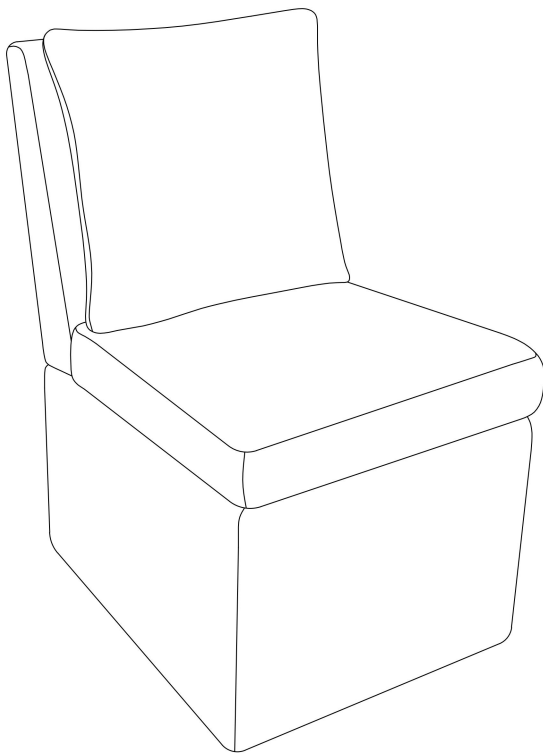

## TOOLS REQUIRED



Screwdriver  
( Not included)



(Included)  
Allen Wrench



2 - People

## ASSEMBLY RATING



EASY —————> DIFFICULT

The Assembly Rating is a 5-point system showing the level of effort needed to assemble a specific product.



## **CHECK BEFORE STARTING**

### **Are you missing anything?**

Double-check all parts, hardware and accessories listed are all accounted for.

### **Check out our Quick Tips!**

We recommend reviewing the pre-assembly handouts. Even experts need a refresher now and then!

### **Should we send any replacements?**

Are there any irregularities or flaws in the parts? We can send replacements!

### **Prep Time!**

Please review the assembly instructions and all diagrams prior to assembling.

# PRE ASSEMBLY INTRODUCTION

We understand building ready-to-assemble furniture can be a challenging experience for some. To help avoid confusion, we have provided some helpful tips that may speed up the process.



### Teamwork

ALWAYS have at least two people to help with transporting and assembling the product to avoid potential injury and/or damage.



### Suitable Location

Assembling near the area of the intended location is highly recommended.



### Sufficient Space

Make sure you have enough space to move around during the assembly.



### Avoid Scratches

Use cardboard, blankets or a carpeted area while assembling furniture to prevent scratches and damages.



### Flat Surface

Make sure the furniture rests on a flat and level surface with each leg evenly touching the floor.

# ASSEMBLY AND CARE ADVICE



**FAILURE TO FOLLOW THE GUIDELINES BELOW MAY RESULT IN INJURY AND/OR PROPERTY DAMAGE.**



Position each part correctly and insert screws or bolts into their respective holes.

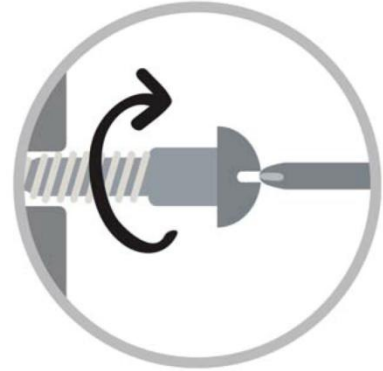

Turn clockwise to tighten and only tighten when step is completed or when instructed to do so.



Use the appropriate hand tools or power tools for assembly. Select steps, such as tightening screws and/or bolts, may require hand tools to avoid causing damage during assembly.



Save the instructions and store any supplied tools for later maintenance.



After two weeks, check and tighten any loose hardware and repeat again every six months thereafter.

**IT IS THE USER'S RESPONSIBILITY TO MAINTAIN THE FURNITURE. THE HARDWARE MAY LOOSEN OVER TIME AND MAY CAUSE THE FURNITURE TO BE WOBBLY AND UNABLE TO SUPPORT ITS INTENDED WEIGHT CAPACITY. THIS MAY LEAD TO COLLAPSE AND MAY CAUSE SERIOUS INJURY.**

# DINING CHAIR



- Please keep instructions for future reference.
- Check the quantity and irregularity of parts and hardware before you start.

## PARTS

1

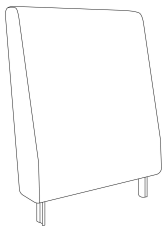

BACK REST

1 pc.

2

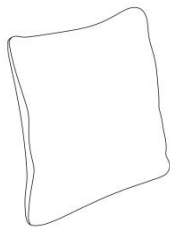

BACK CUSHION

1 pc.

3

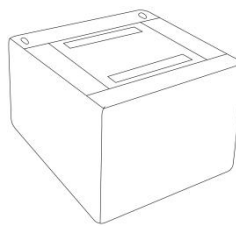

SEAT BASE

1 pc.

4



SEAT CUSHION

1 pc.

# ASSEMBLY INSTRUCTIONS

---

## 1

BACK CUSHION **2** x1pc

SEAT BASE **3** x1pc

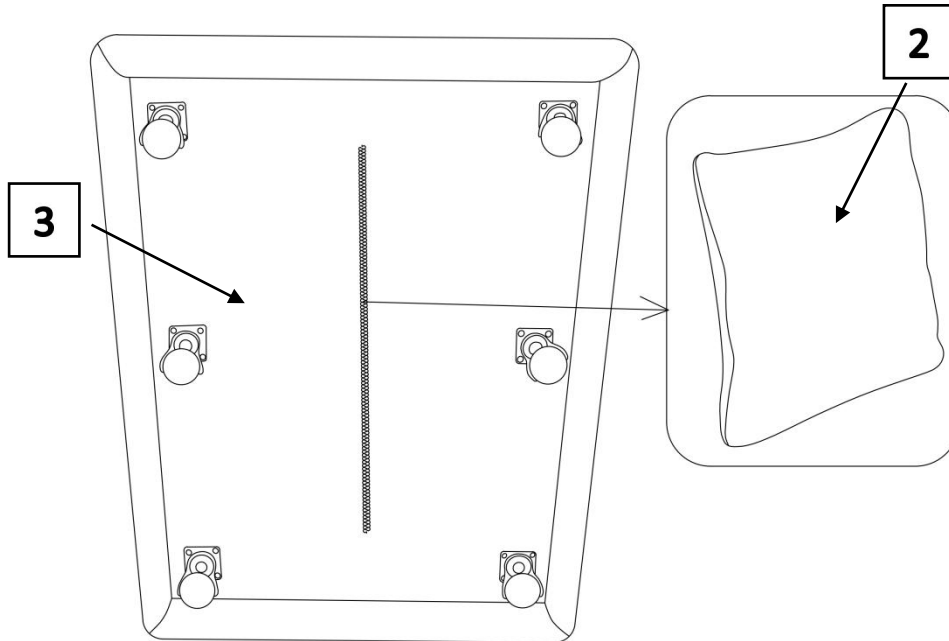

## 2

BACK REST **1** x1pc

SEAT BASE **3** x1pc

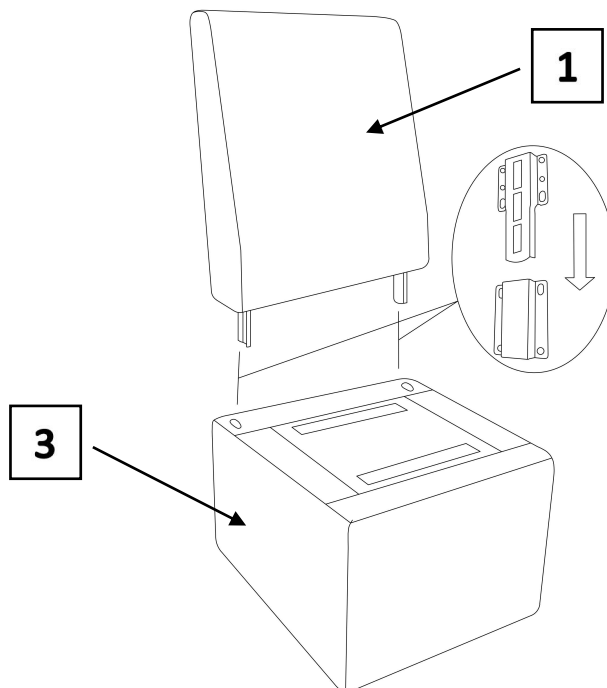

# ASSEMBLY INSTRUCTIONS

## 3

SEAT CUSHION [4] x1pc

SEAT BASE [3] x1pc

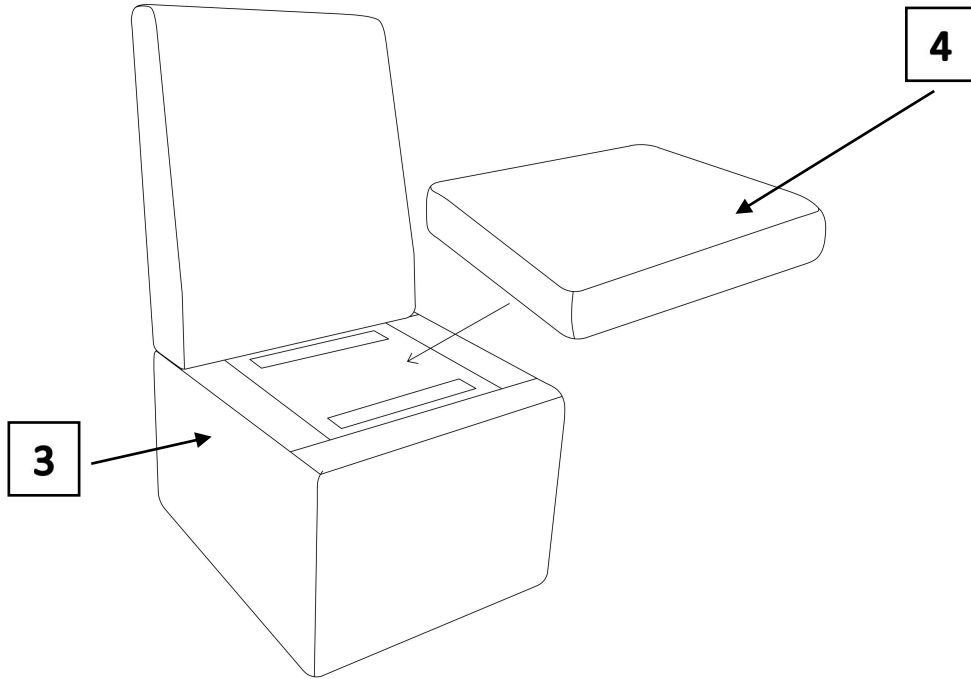

## 4

BACK REST [1] x1pc

BACK CUSHION [2] x1pc

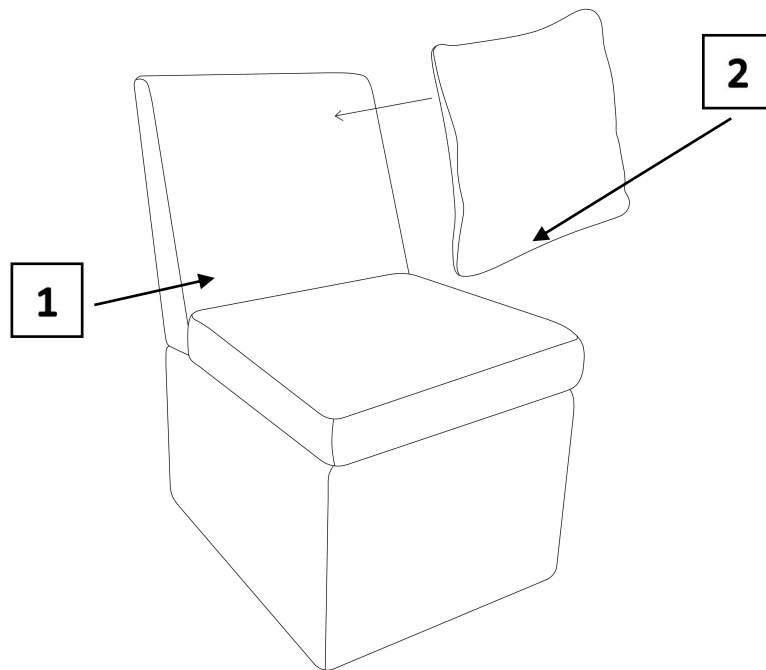

# ASSEMBLY INSTRUCTIONS

---

4

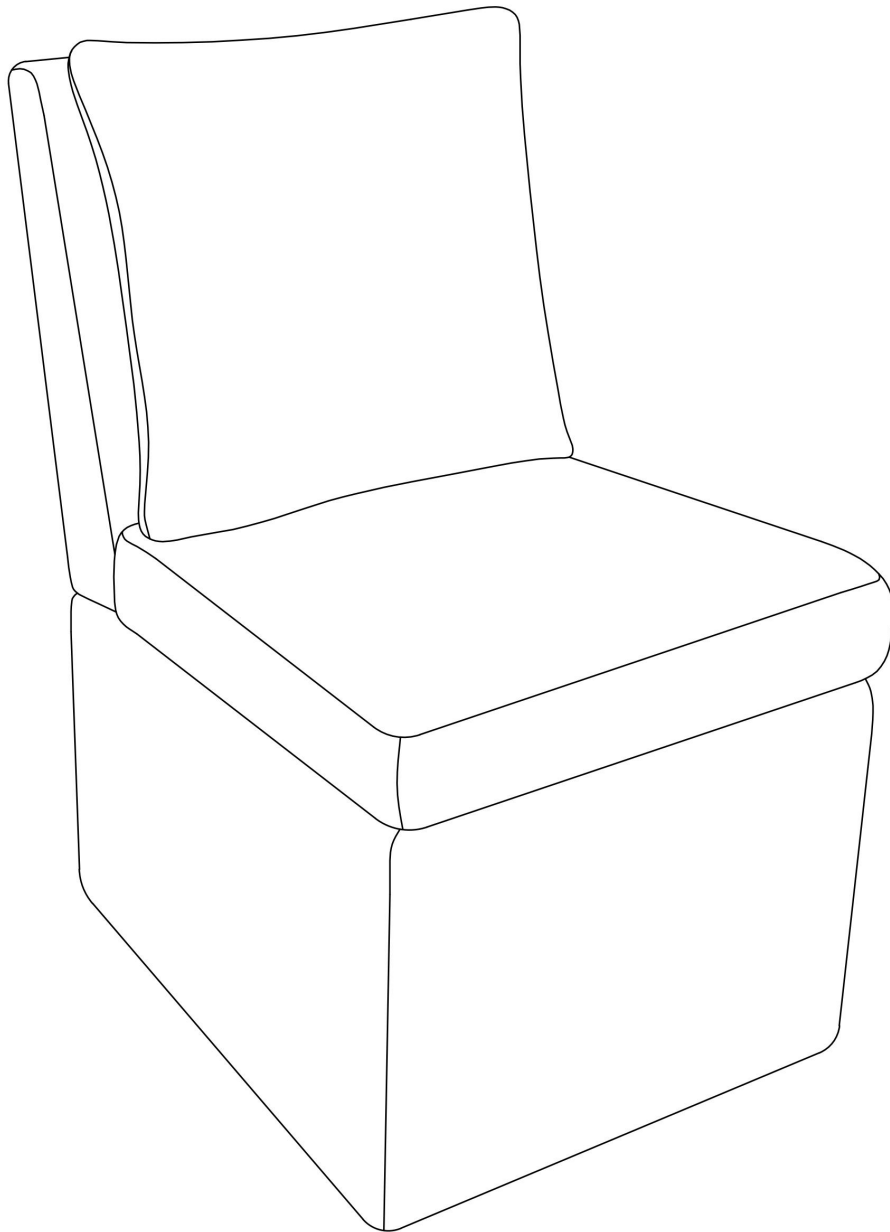

## ASSEMBLY COMPLETED



Please ensure the furniture rests on an even and flat surface. If the product wobbles or feels loose, double-check all bolts and/or screws are properly tightened and secured.

✓ **Keep this handy!**

Please retain this instruction manual and any order-related information for future reference.

✓ **Lift, don't drag!**

To avoid damage to product please always LIFT the product when transporting or adjusting the placement.

---

This product is intended for RESIDENTIAL USE ONLY and not for commercial use.