

Instruction Manual

Wall Cabinet

SHX-DG2108-X-0-S

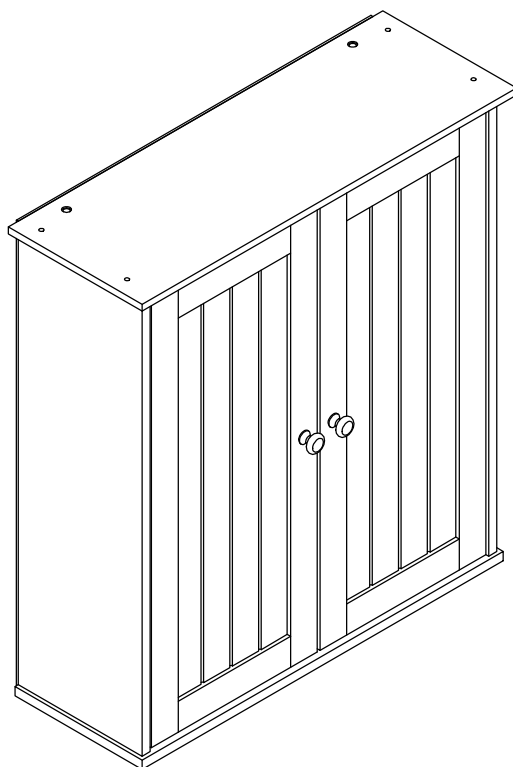

Thank you for shopping with us!

If any part is missing, broken upon receipt or you need any help from us.







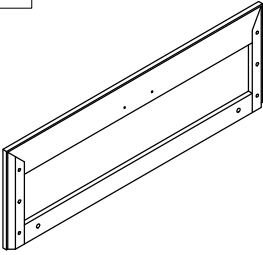
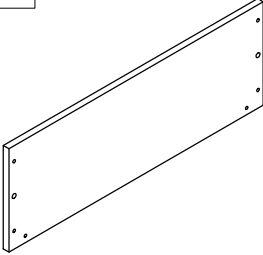
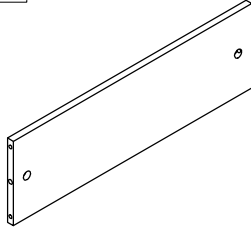
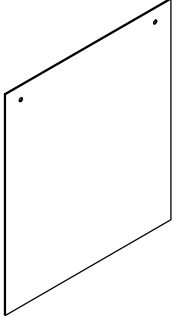
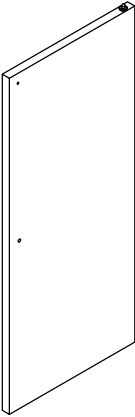
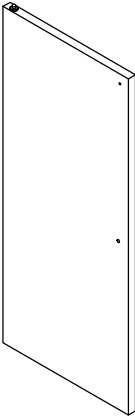
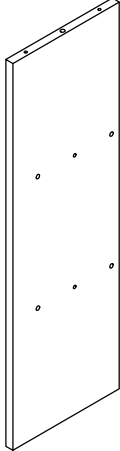
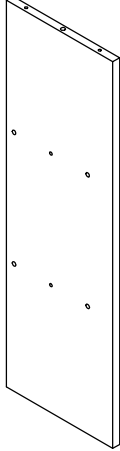



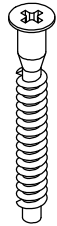

For the FASTEST SOLUTION, please FIRSTLY CONTACT US at our
after-sales email:

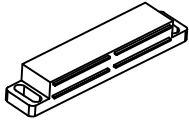
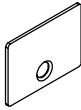
CSsince1987@hotmail. com!

PART LIST

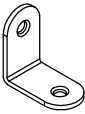
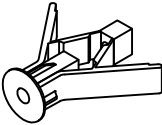
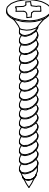
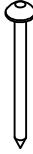
<p>A</p> 	<p>B</p> 	<p>C</p> 	<p>D</p> 
<p>Top Panel 1 PC</p>	<p>Bottom Panel 1 PC</p>	<p>Fixed Shelf Panel 2 PCS</p>	<p>Back Panel 1 PC</p>
<p>E</p> 	<p>F</p> 	<p>G</p> 	<p>H</p> 
<p>Left Door 1 PC</p>	<p>Right Door 1 PC</p>	<p>Left Panel 1 PC</p>	<p>Right Panel 1 PC</p>

HARDWARE LIST

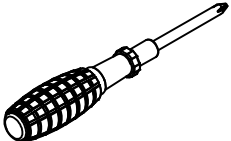
<p>#1</p>  <p>Ø5*40mm</p>	<p>#2</p>  <p>Ø6*30mm</p>	<p>#3</p> 	<p>#4</p>  <p>M4*20mm</p>	<p>#5</p>  <p>70*17*13mm</p>
<p>Screw</p> <p>8 PCS (Extra 2)</p>	<p>Wood Dowel</p> <p>12PCS (Extra 2)</p>	<p>Handle</p> <p>2 PCS</p>	<p>Round Head Bolt</p> <p>2 PCS (Extra 1)</p>	<p>Door Magnet</p> <p>1 PC</p>
<p>#6</p>  <p>30*22*1mm</p>	<p>#7</p>  <p>Ø3*12mm</p>	<p>#8</p>  <p>M5*20mm</p>	<p>#9</p>  <p>Ø3.5*14mm</p>	<p>#10</p>  <p>30*30*17mm</p>
<p>Door Small Plate</p> <p>2 PCS</p>	<p>Screw</p> <p>2 PCS (Extra 1)</p>	<p>Bolt</p> <p>2 PCS (Extra 1)</p>	<p>Screw</p> <p>2 PCS (Extra 1)</p>	<p>Angel Iron</p> <p>2 PCS</p>
<p>#11</p> 	<p>#12</p>  <p>Ø4*45mm</p>	<p>#13</p> 	<p>#14</p>  <p>Ø6*35mm</p>	<p>#15</p>  <p>Ø15*9mm</p>
<p>Wall Anchor</p> <p>2 PCS</p>	<p>Long Screw</p> <p>2 PCS</p>	<p>Piton</p> <p>22 PCS (Extra 4)</p>	<p>Cam-bolt</p> <p>4PCS (Extra 1)</p>	<p>Cam-lock</p> <p>4PCS(Extra 1)</p>
				
<p>Hammer</p> <p>1 PC</p>	<p>Phillips Screwdriver</p> <p>1 PC</p>			

ASSEMBLY OVERVIEW

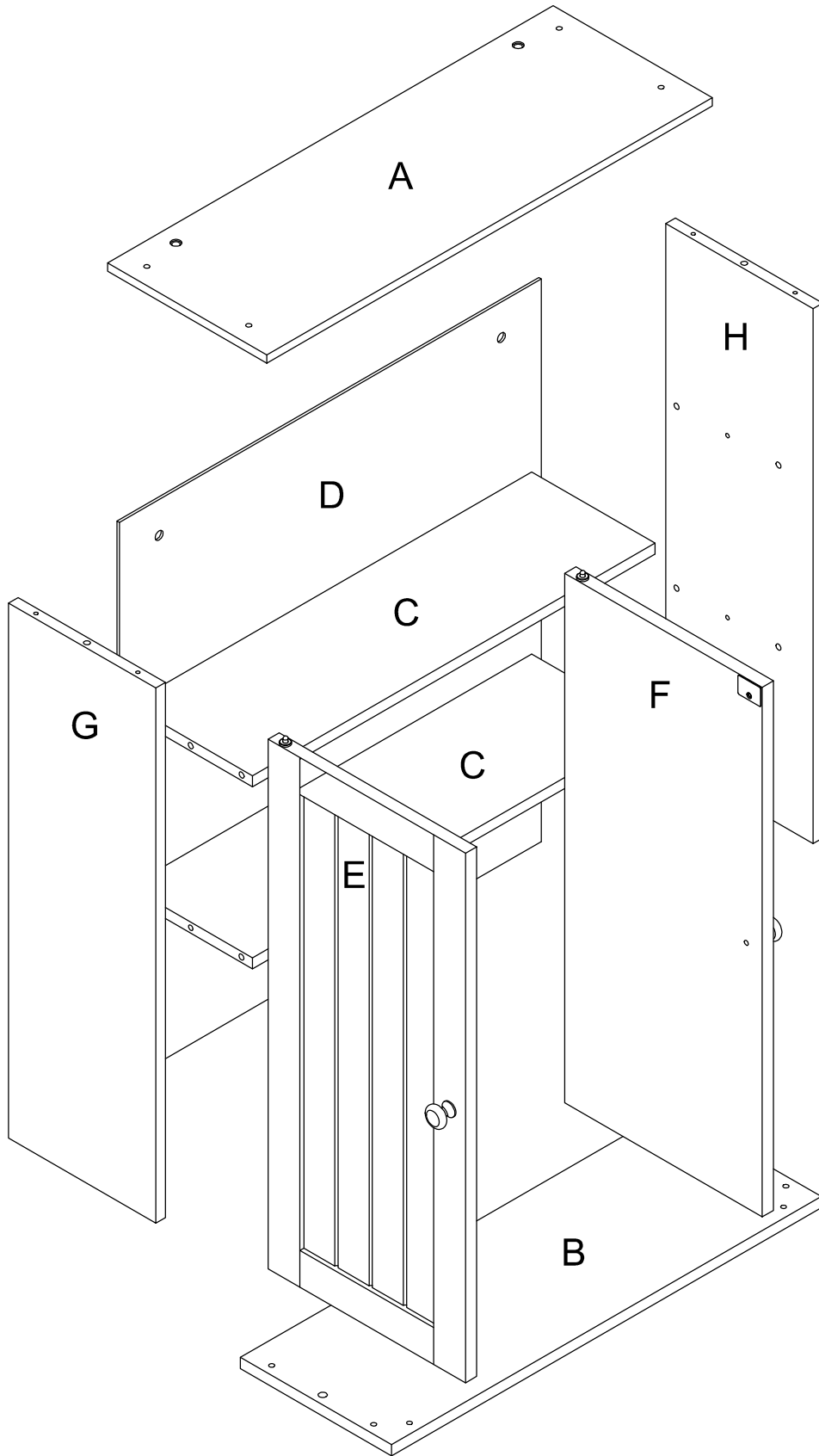

Step 1.

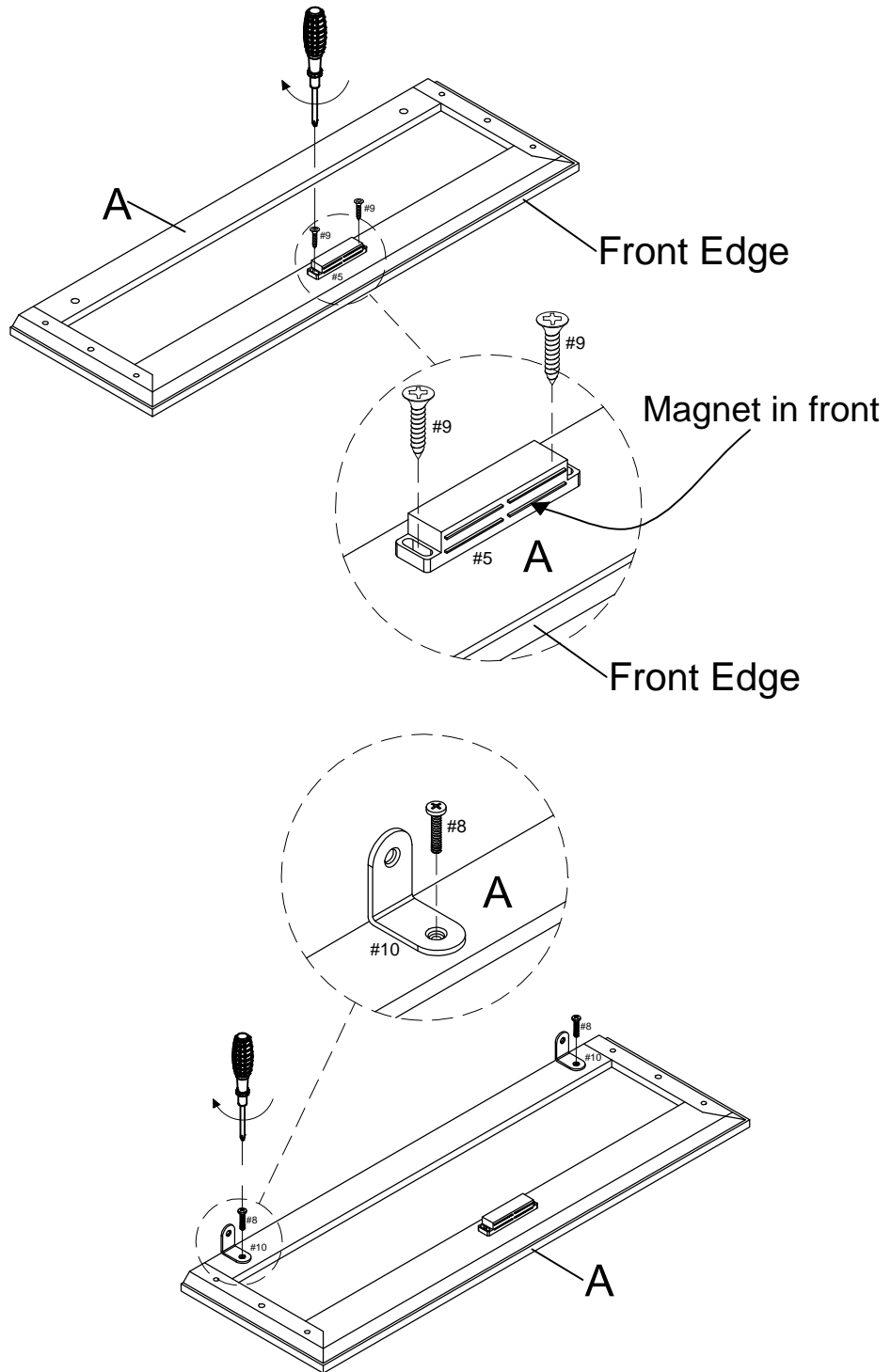
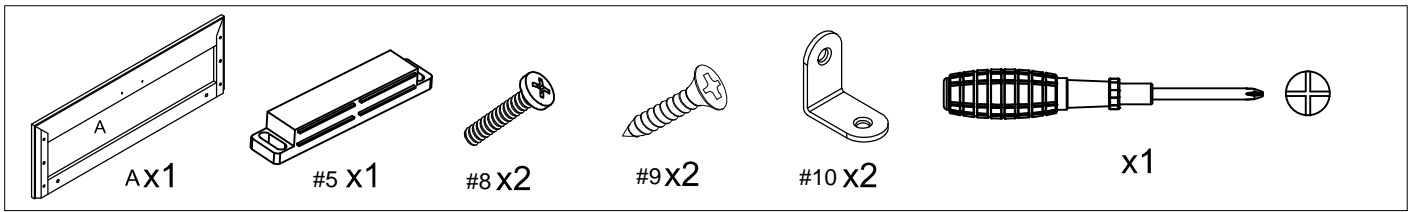

Step 2.

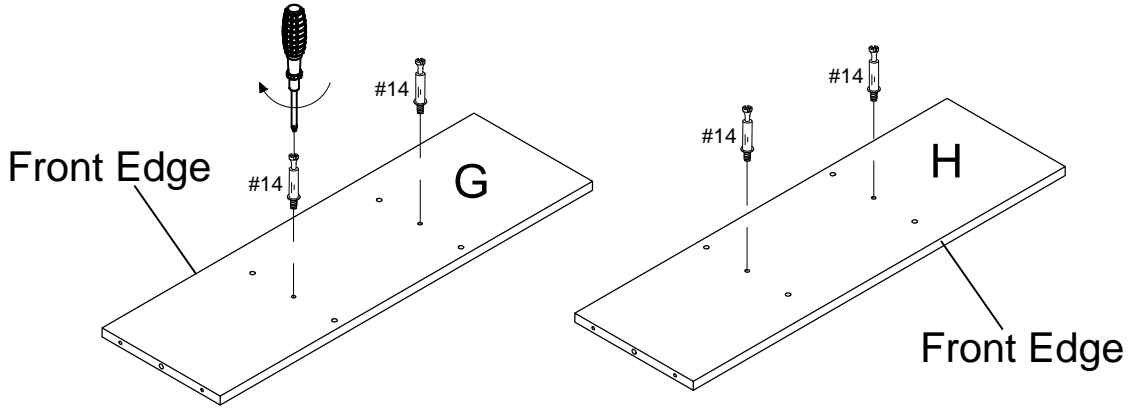
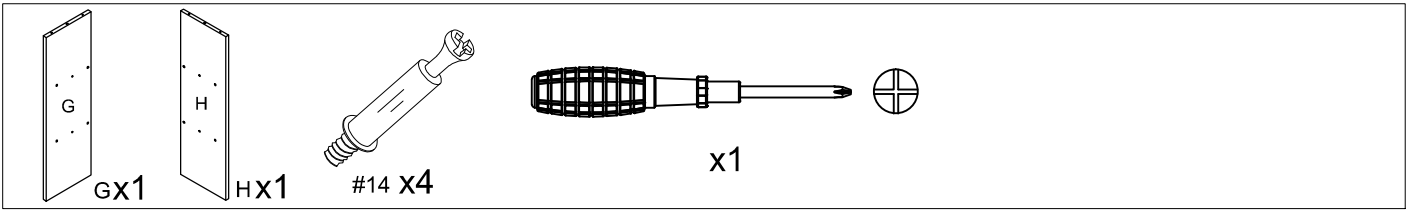

Step 3.

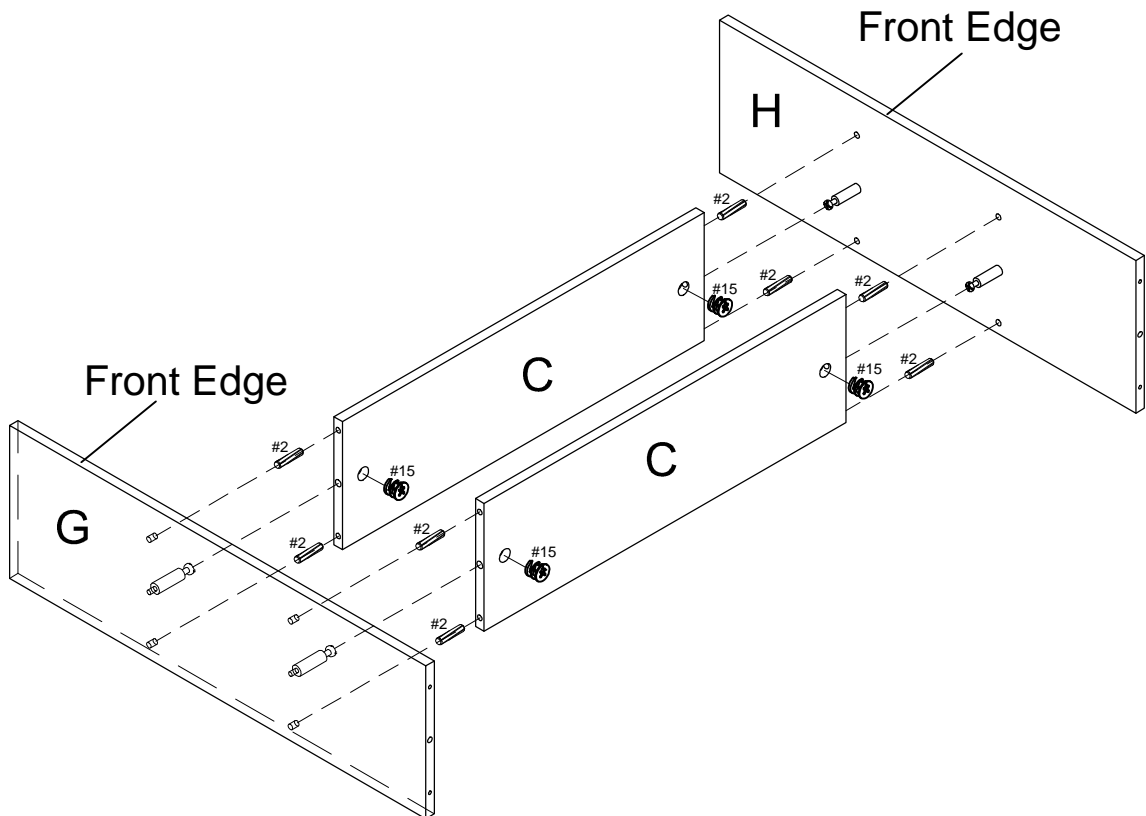

Step 4.

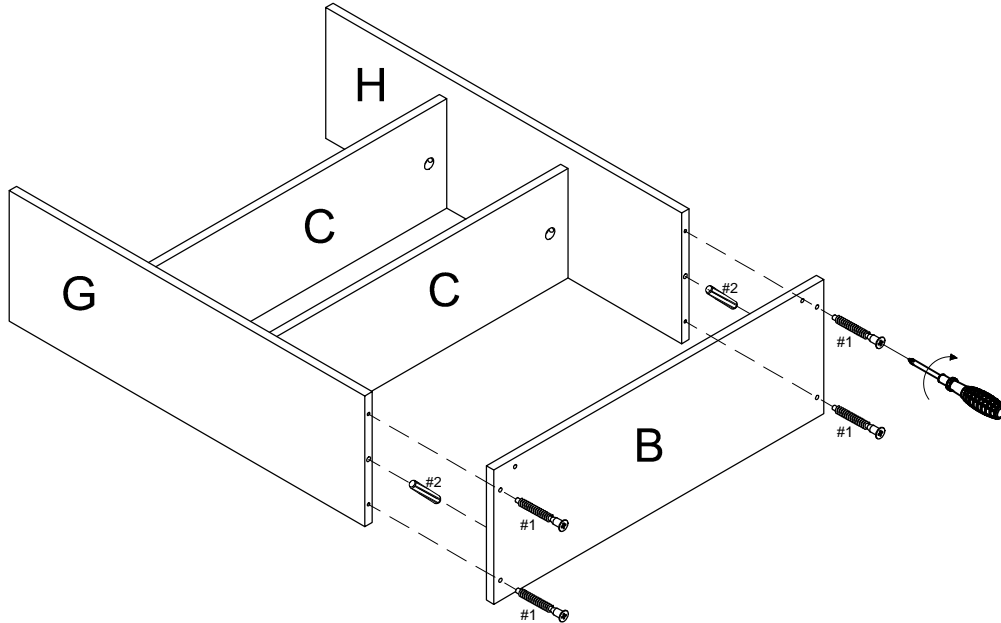
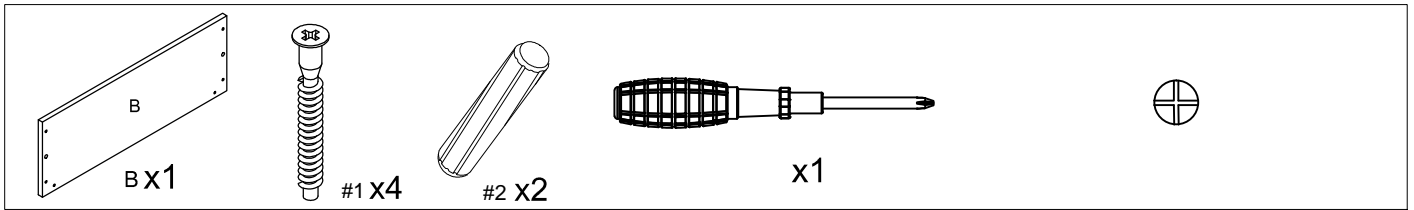

Step 5.

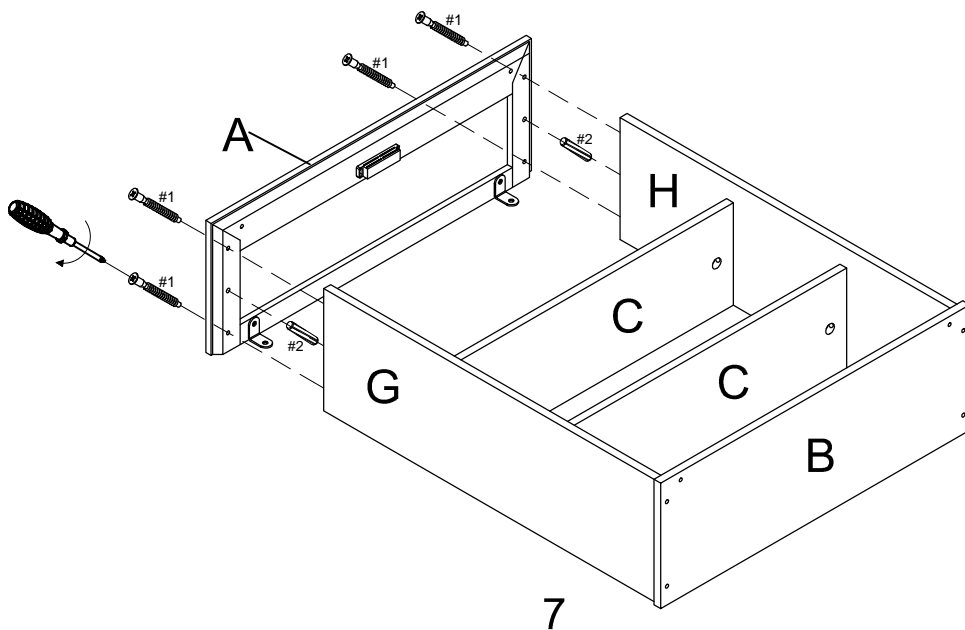
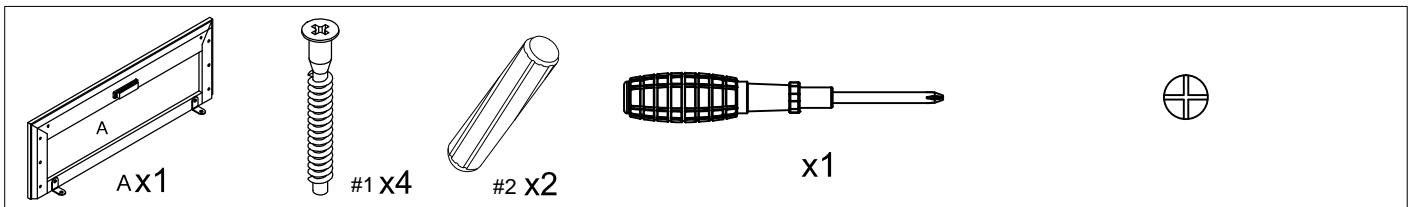

Step 6.

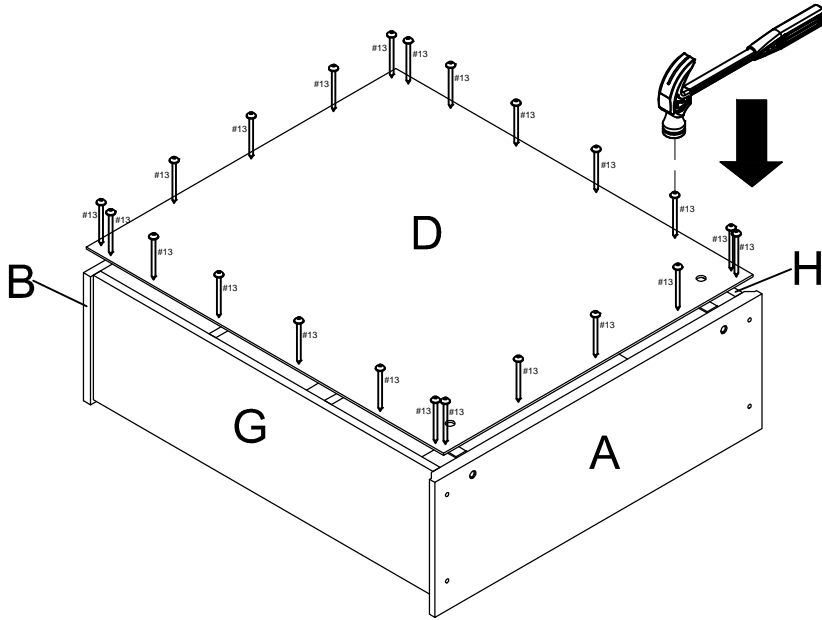
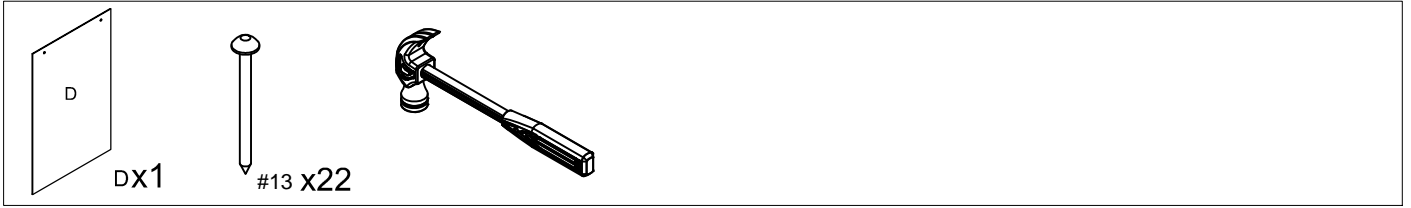

Step 7.

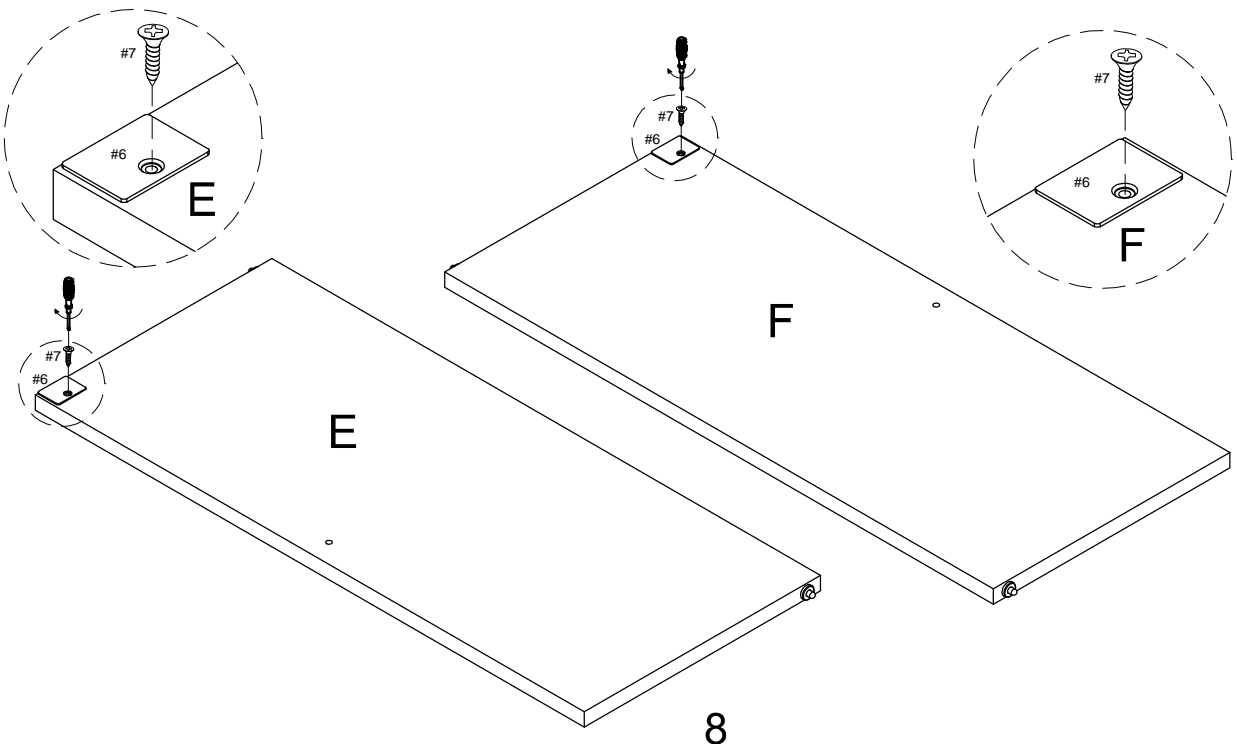
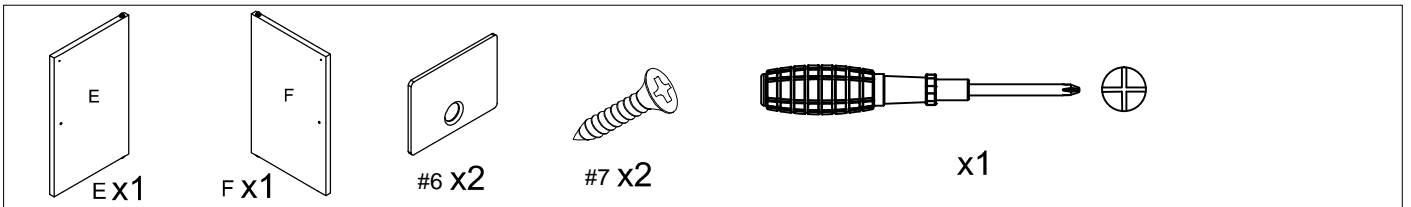

Step 8.

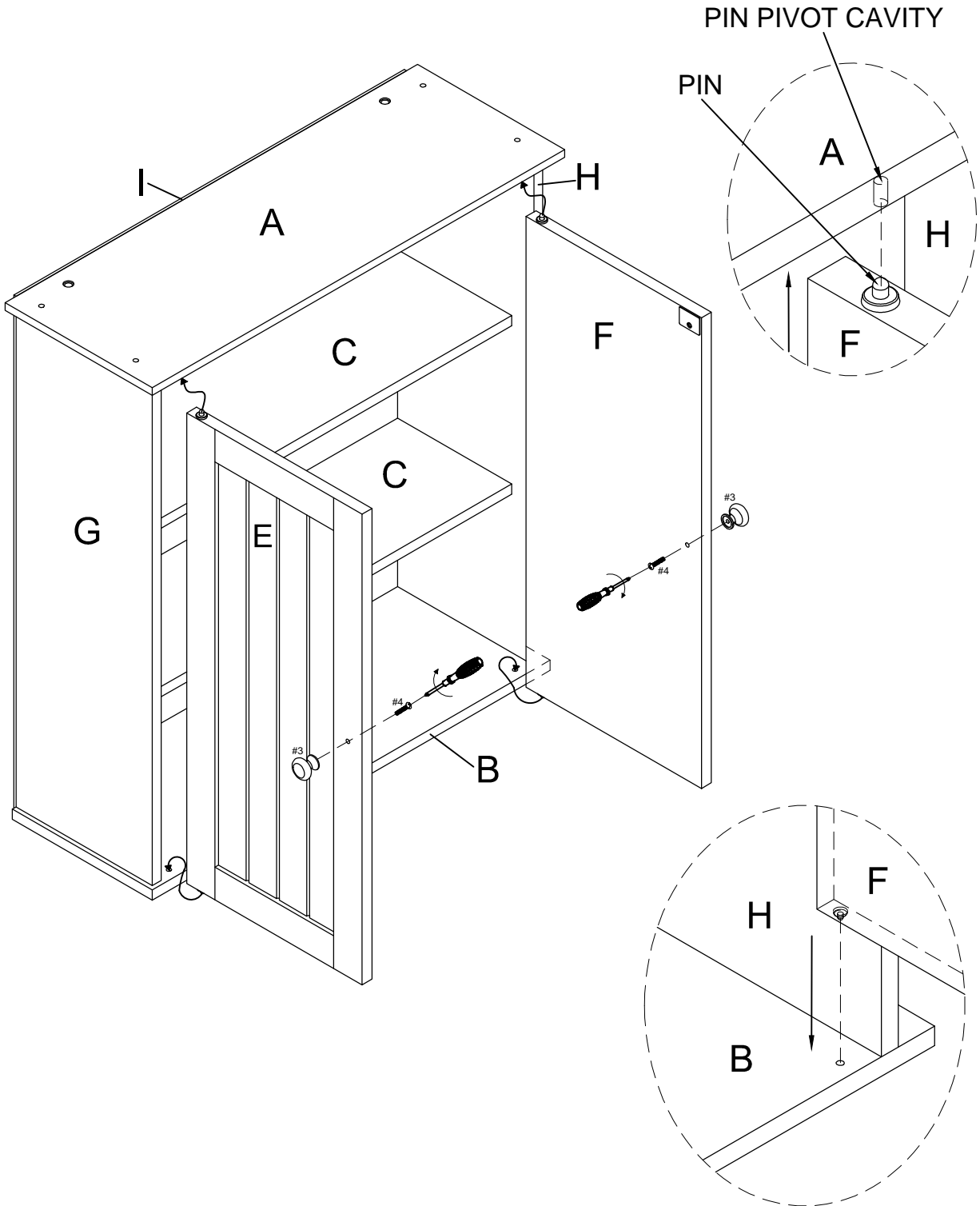

Step 9.

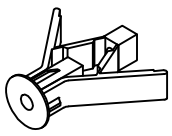

#11 X2

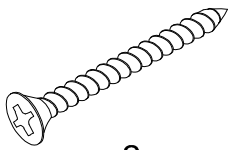

#12 X2

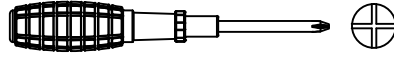

x1

Safety strap kit must be installed to prevent tipping, damage and/or injury.

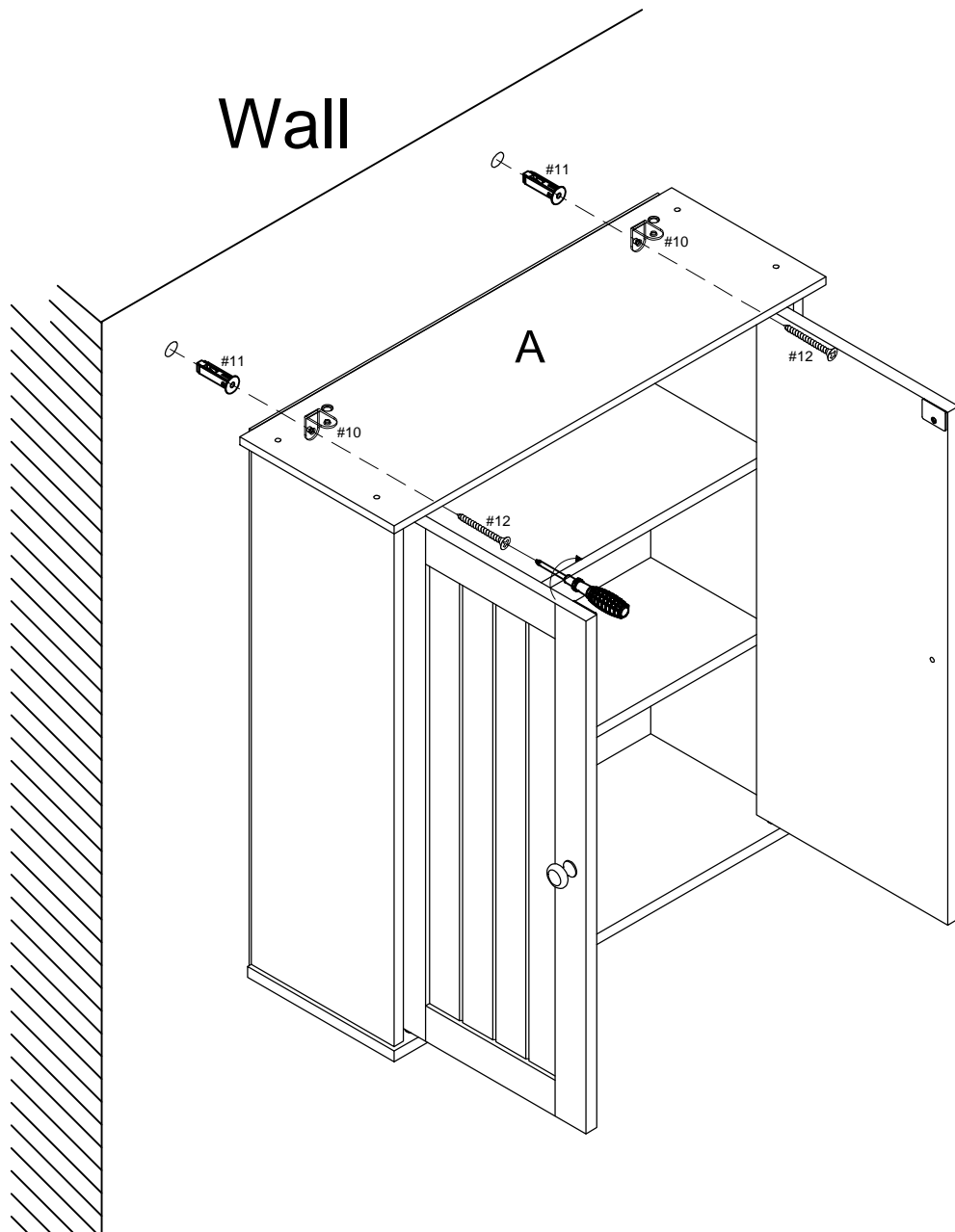

Warning:

Seller is responsible for the product-related issues occurred upon receipt, but will not be responsible for the personal injury, property damage or loss resulting from the incorrect assembly, improper use, inadequate maintenance or neglect of this product.

Notes:

1. ASSEMBLY PREPARATION AND TIPS FOR ASSEMBLY

- 1). Remove all packaging materials, staples and packing straps from the carton.
- 2). Refer to Parts List and Hardware List, and ensure parts and hardware are correct before assembly.
Contact customer service for missing parts.
- 3). Place all wooden parts on a clean, flat and soft surface (e.g. carpet or rug) to prevent scratch and damage to parts.
- 4). Allow ample room for assembly and assemble the product near where the product will be placed.
- 5). During assembly, do not over-tighten any fittings as this may cause damage.
- 6). Always place the product on a flat, level surface.

2. CARE AND MAINTENANCE

- 1). KEEP ALL HARDWARE PARTS OUT OF REACH OF CHILDREN.
- 2). Wipe clean with a soft, dry cloth; avoid the use of harsh chemicals or household cleaners as they may damage the exterior finish of the furniture.
- 3). Hardware may loosen over time. Periodically, check that all connections are tight; re-tighten as necessary.

3. TIPS TO PROTECT & CARE FOR YOUR FURNITURE

- 1). Avoid placing your furniture in direct sunlight, as sunlight causes fading.
- 2). Use a protective pad when writing on the furniture surface.
- 3). Use cutting boards and trivets for food preparation in order to avoid damaging the top for the unit.