







ASSEMBLY INSTRUCTIONS

SOFA - 3 SEATER

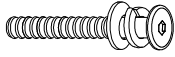
IMPORTANT NOTE :

- * PLACE ALL WOODEN PARTS ON A CLEAN AND SMOOTH SURFACE SUCH AS A RUG OR CARPET TO AVOID THE PARTS FROM BEING SCRATCHED.
- * BEFORE YOU BEGIN, KINDLY FOLLOW THE ASSEMBLY INSTRUCTIONS STEP BY STEP.

HARDWARE LIST

| | | | |
|---|---|---|-------|
| A | JCBC M6 x 50mm + S/W M6 + F/W M6 x 13mm |  | 6PCS |
| B | ALLEN KEY M4 |  | 1PC |
| C | BARREL NUT M6 x 13mm |  | 4PCS |
| D | WOOD BUTTON Ø 14.5 |  | 6PCS |
| E | FH SCREW #8 X 32mm |  | 12PCS |
| F | WOOD DOWEL M10 x 40mm |  | 4PCS |

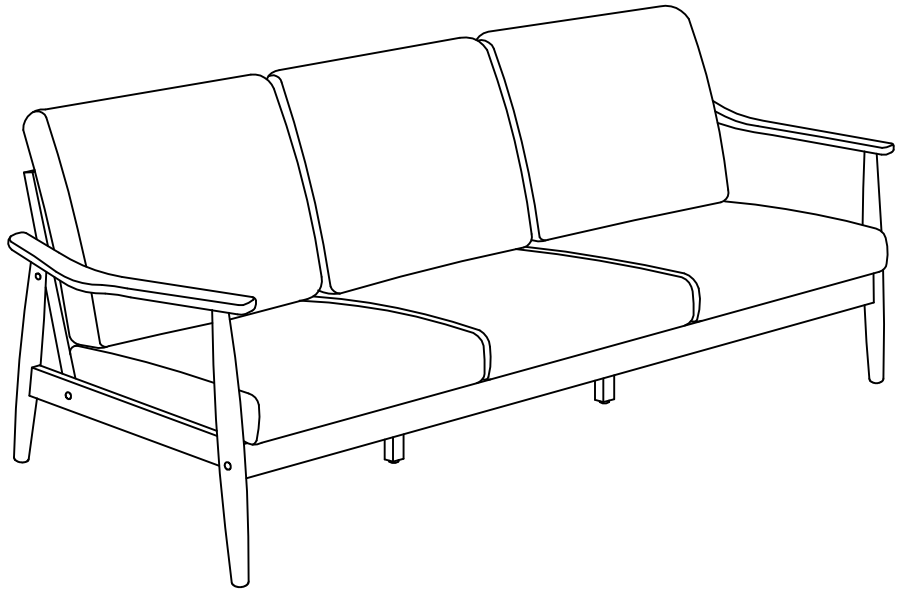

COMPLETED SOFA ASSEMBLY.

PART LIST

| | | |
|---|----------------|------|
| 1 | SOFA LEG (L/R) | 2PCS |
| 2 | FRONT RAIL | 1PC |
| 3 | BACK FRAME | 1PC |
| 4 | SEAT FRAME | 1PC |
| 5 | SOFA BACK REST | 3PCS |
| 6 | SOFA SEAT REST | 3PCS |
| 7 | CENTER LEG | 2PCS |

STEP 1

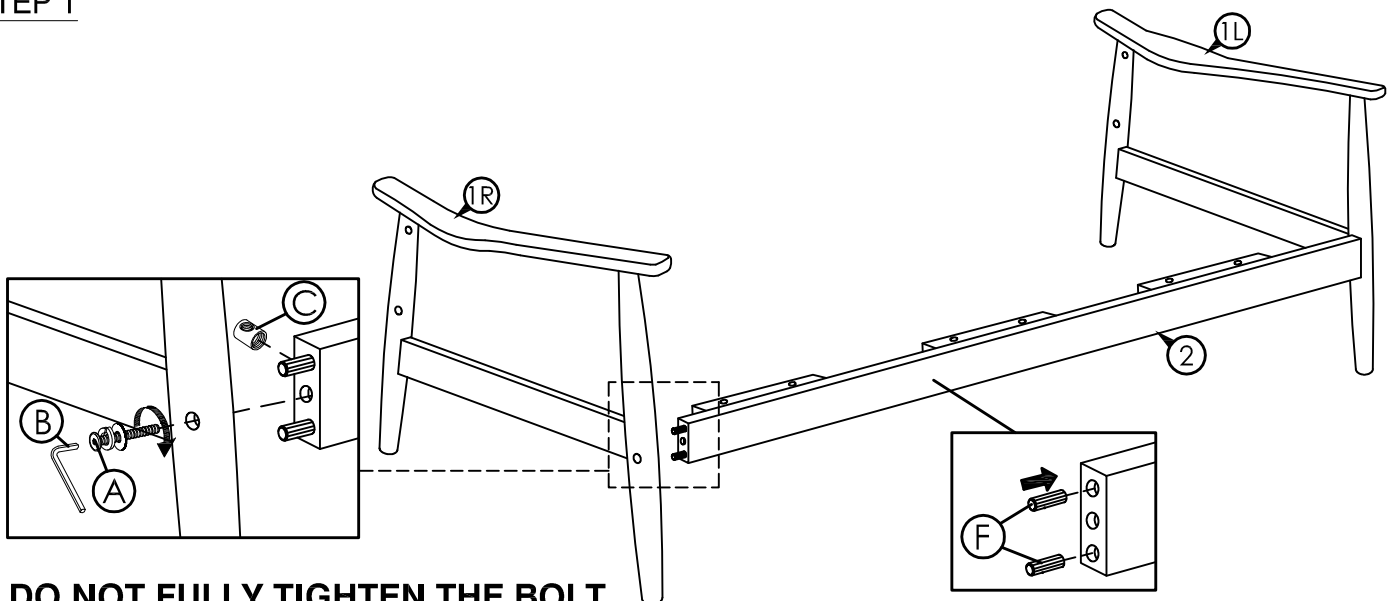

DO NOT FULLY TIGHTEN THE BOLT

ASSEMBLY INSTRUCTIONS

STEP 2

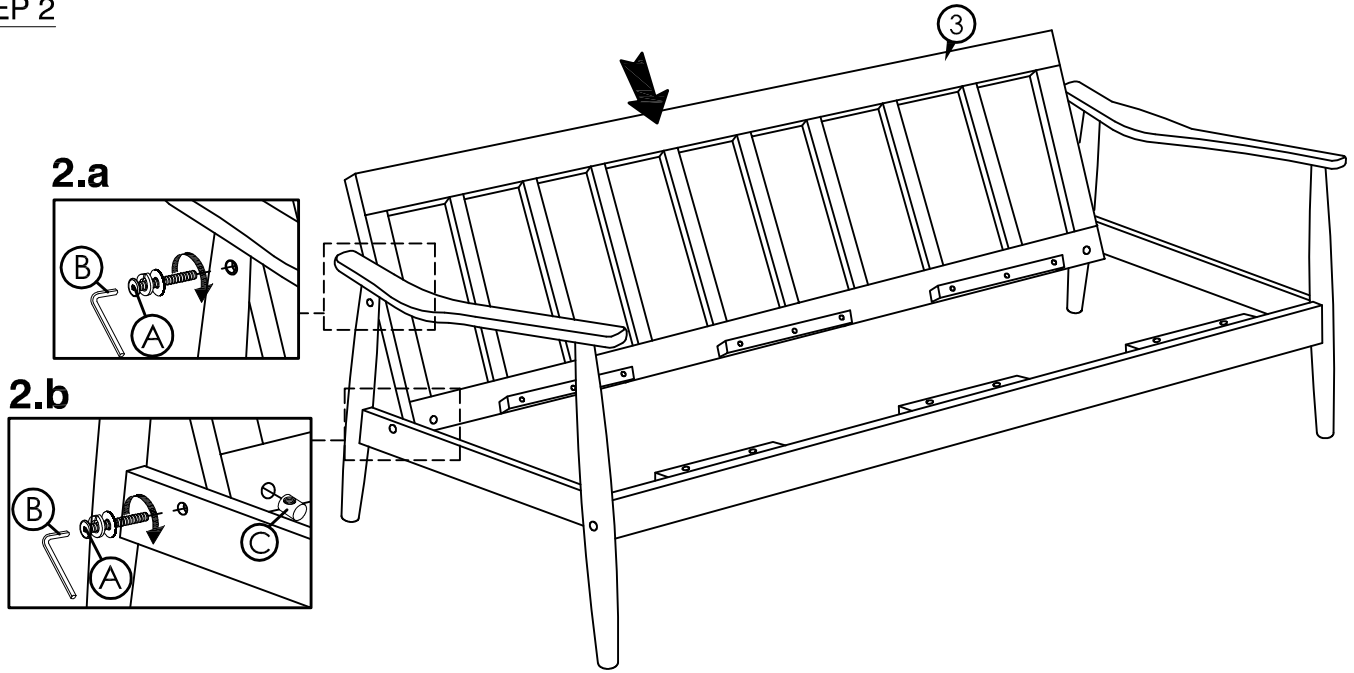

STEP 3

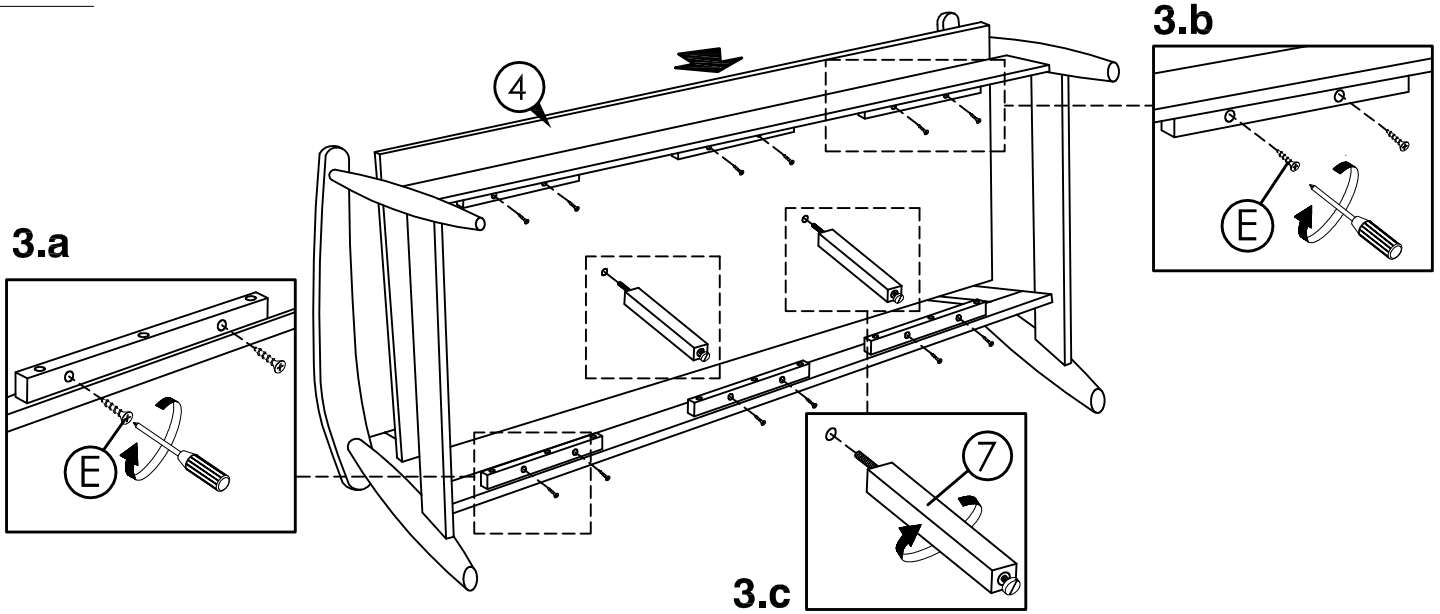

STEP 4

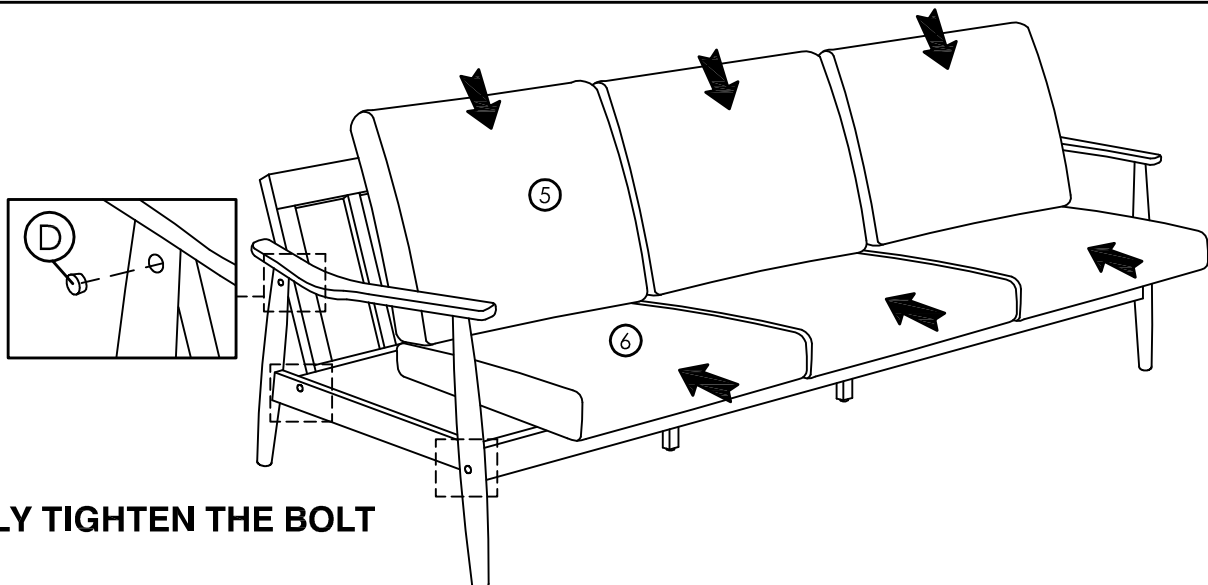

FULLY TIGHTEN THE BOLT