

## Assembly Instructions



*Please visit our website for the most current instructions, assembly tips, report damage, or request parts.*

# General Assembly Guidelines

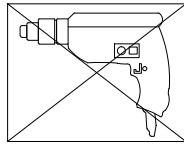

- I. Ensure that all parts and hardware are available before beginning assembly.
- II. Follow each step carefully to ensure the proper assembly of this product.
- III. Two people are recommended for ease in the assembly of this product.
- IV. The main type of hardware used to assemble this product is:bolts.
- V. Power tools should not be used to assemble this product.

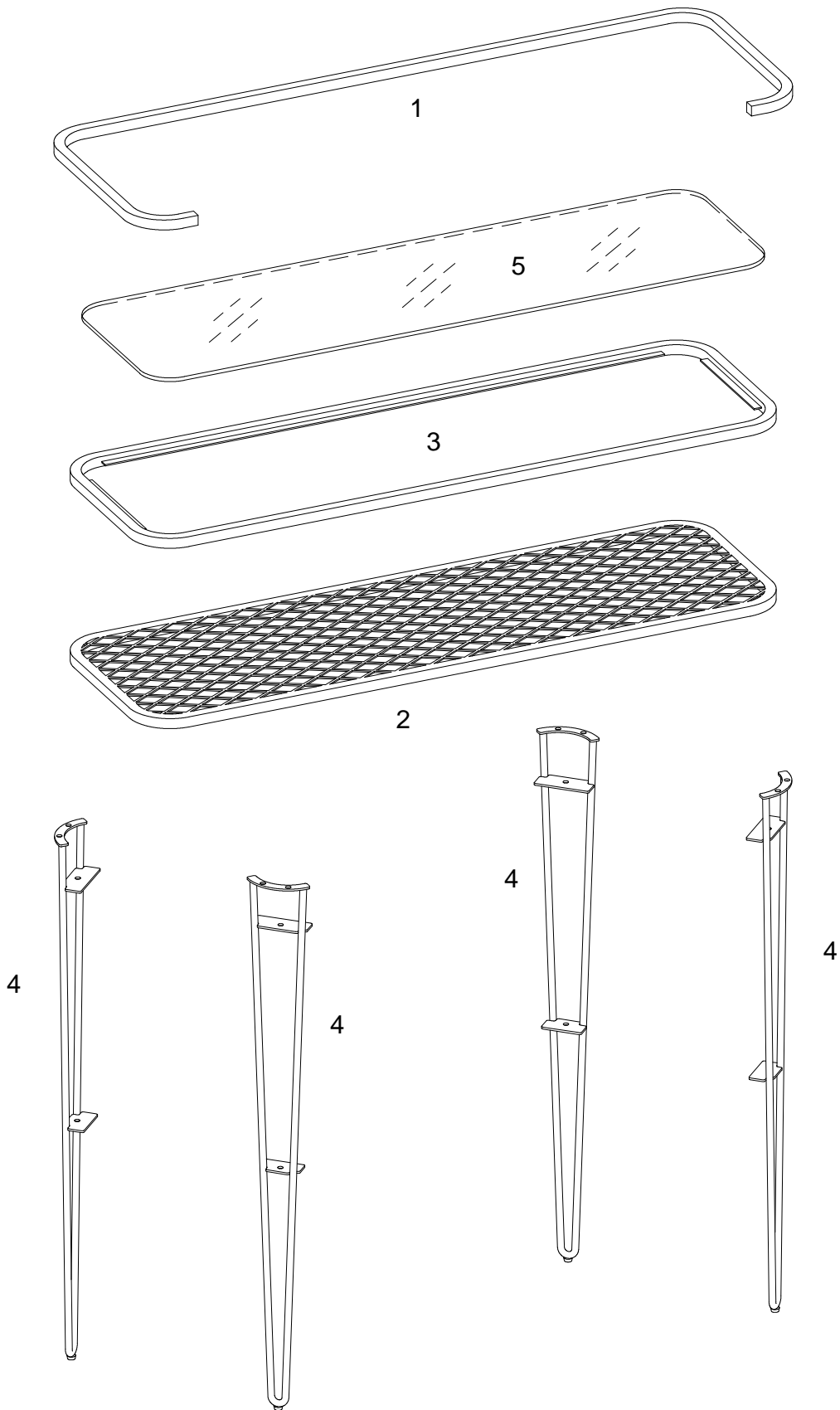

# Parts List



# Hardware List

A		Ø6x12mm	Bolt	16 pcs
B		M 4	Hex Key	1 pcs
C		30x10mm	Glass pads	6 pcs

*The hardware quantities listed above are required for proper assembly.  
Some extra hardware may also have been included.*

# Step 1

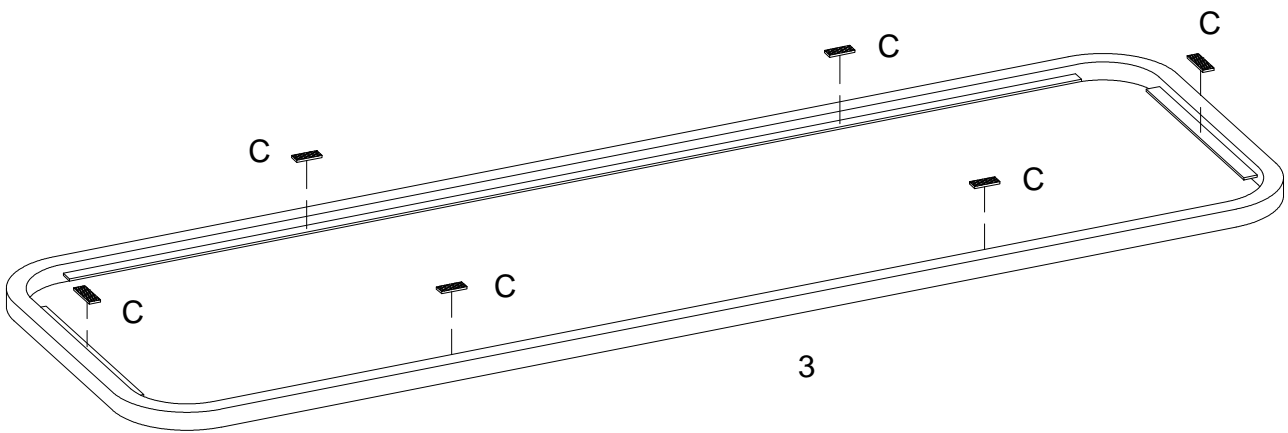
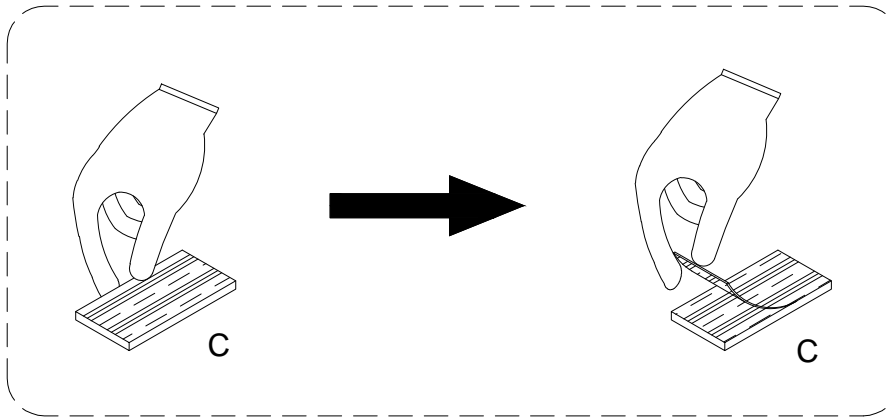

Remove cover tape on glass pads (C), then stick it as diagram.

## Step 2

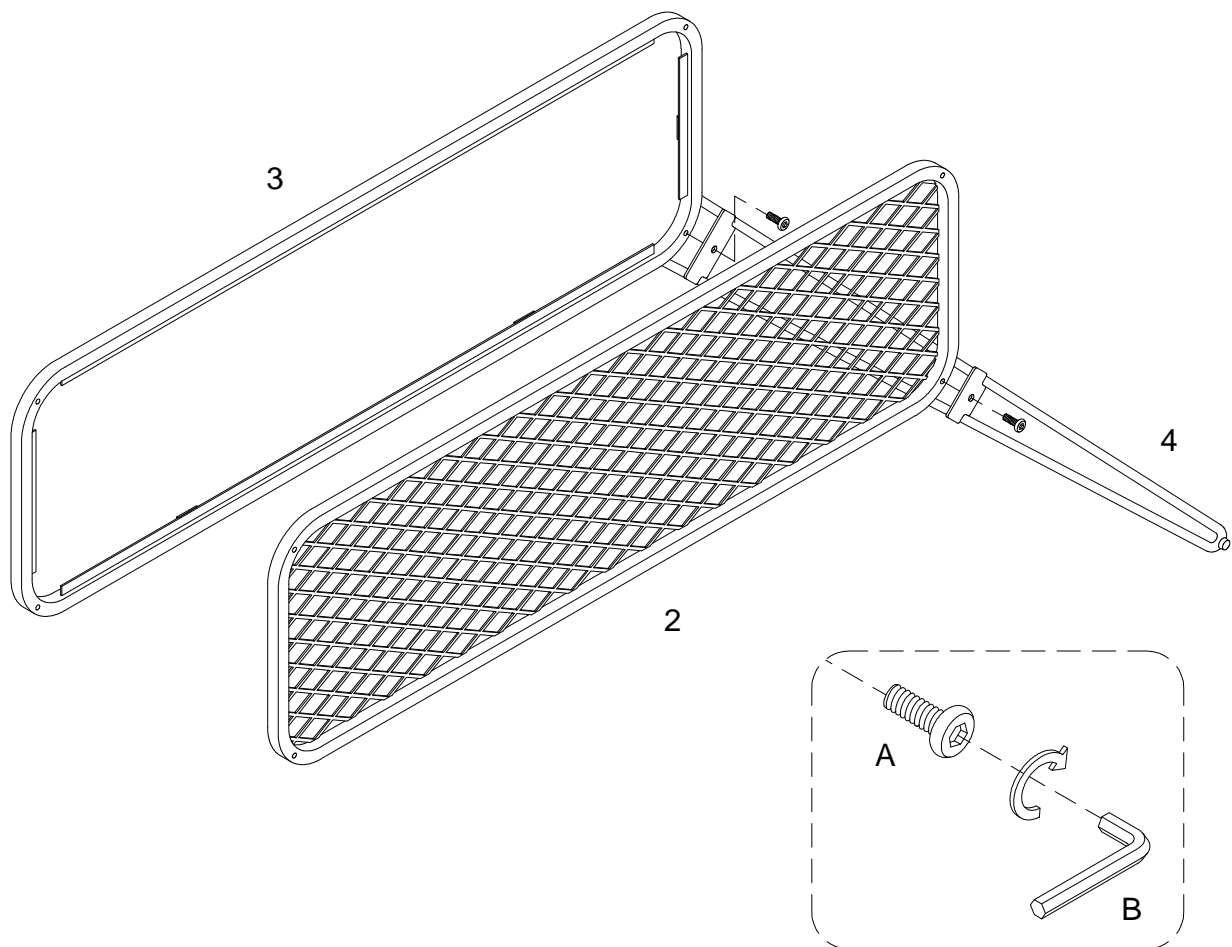

Attach part (4) to part (2, 3) using bolt (A) with hex key (B).

# Step 3

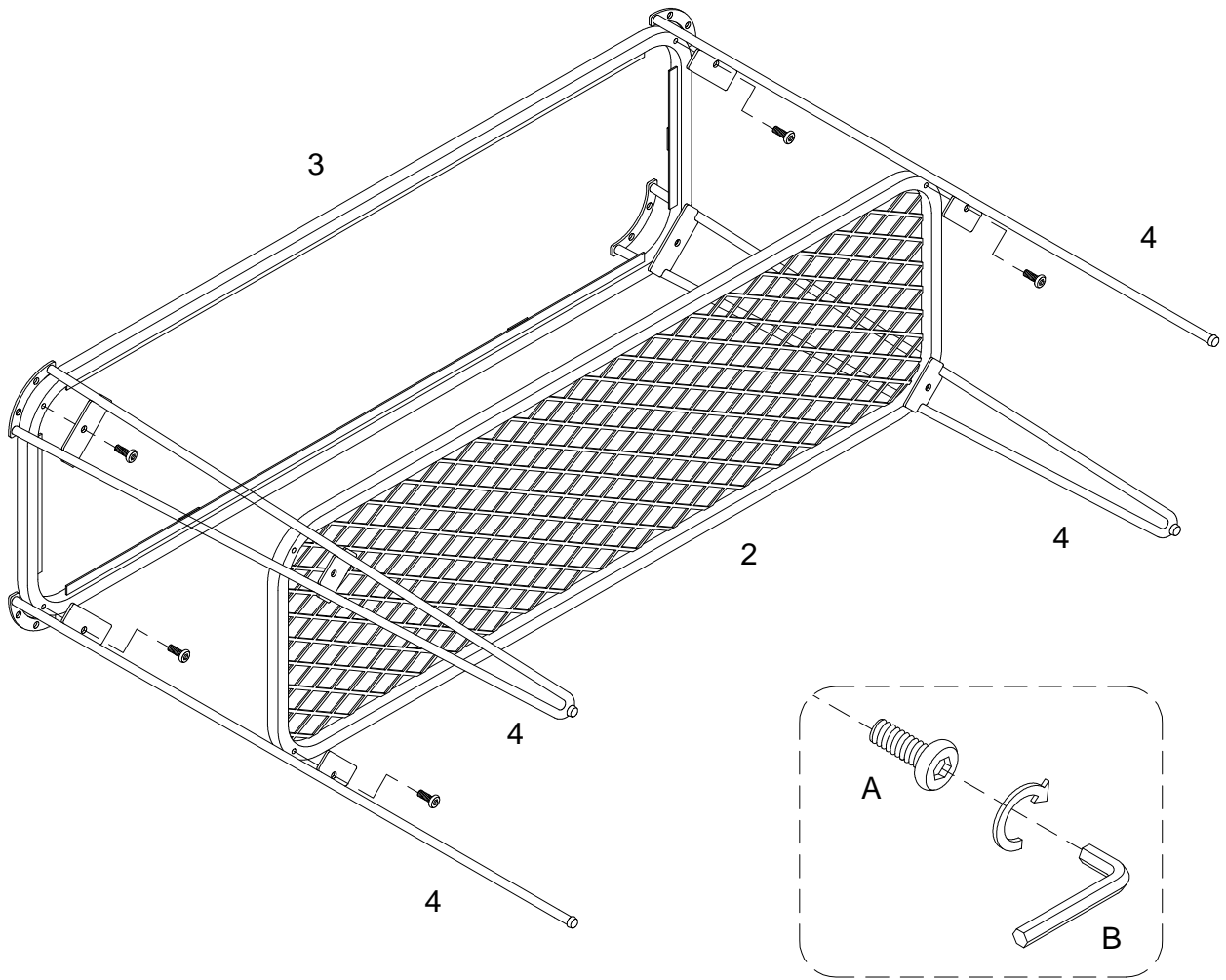

Attach the rest of part (4) to part (2, 3) using bolt (A) with hex key (B).



# Step 5

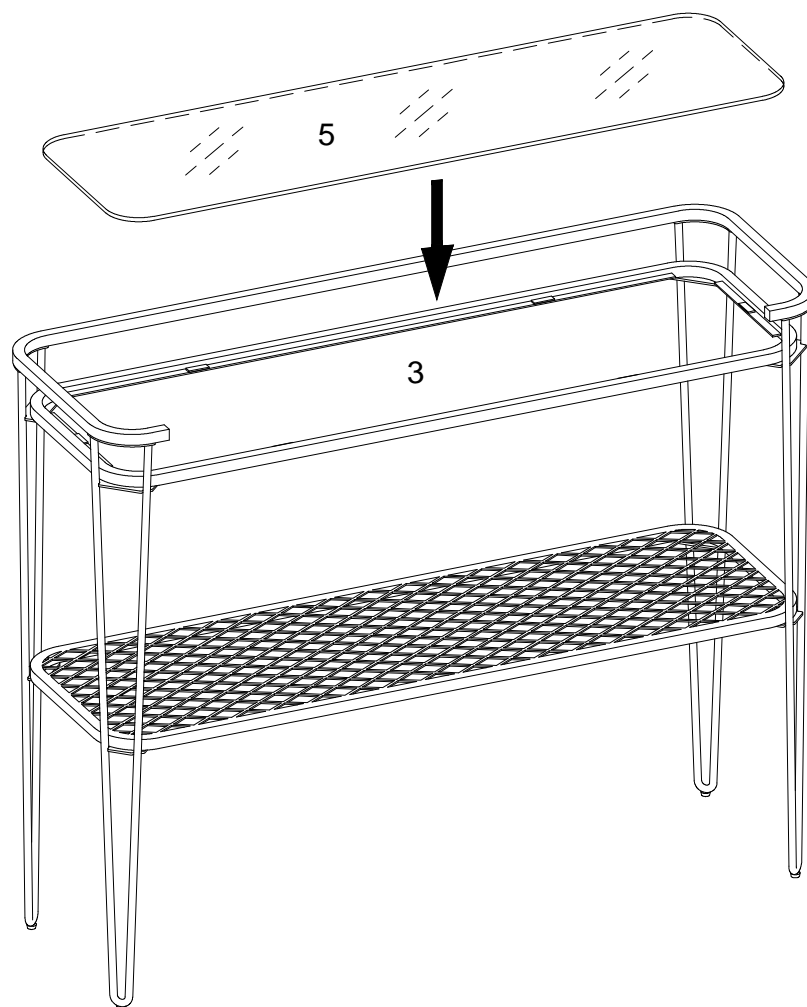

Place part (5) onto part (3) carefully per diagram.

# Step 6



## Final Assembly