

**Furniture of America**<sup>®</sup>

# Assembly Instructions

CM3350T

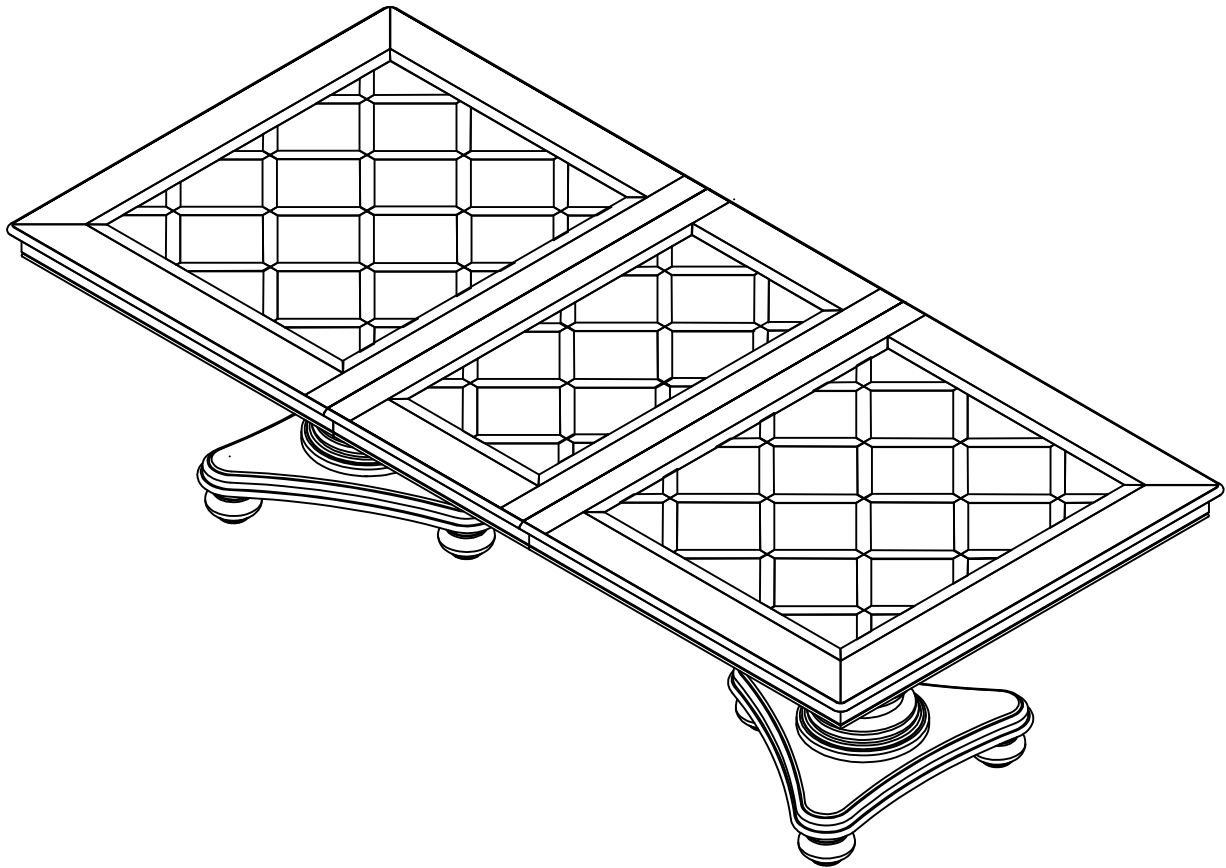

## ASSEMBLY RATING

The Assembly Rating is a 5-point system that shows the degree of effort needed in assembling a specific product (with 1 being easy and 5 being difficult). For some products, two persons are recommended.

EASY



DIFFICULT

Tools Required For Assembly:

Allen Wrench

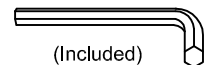

(Included)

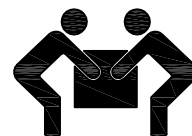

2 PERSONS RECOMMENDED

# ASSEMBLY & CARE ADVICE

FOR YOUR FURNITURE TO LAST, CORRECT ASSEMBLY AND PROPER MAINTENANCE ARE NECESSARY. PLEASE FOLLOW THE INFORMATION PROVIDED BELOW TO FULLY ENJOY YOUR FURNITURE.

## BASIC ASSEMBLY TECHNIQUES



When lock or spring washer is used in an assembly, please make sure the lock or spring washer is placed between the larger flat washer and the head of the screw or bolt.



Position each part correctly and insert screws or bolts into their respective holes by hand tighten or using the proper hand tool. Only tighten when step is completed or when instructed to do so.

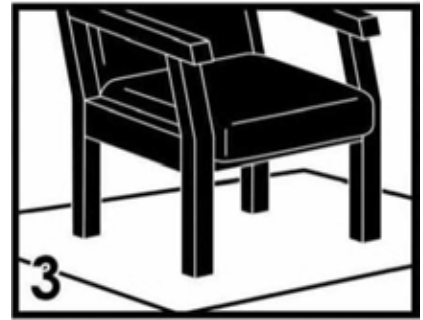

Use cardboard or carpet area when assembling furniture to prevent scratches. Make sure the furniture rests on a flat and level surface with each leg evenly touching the floor.

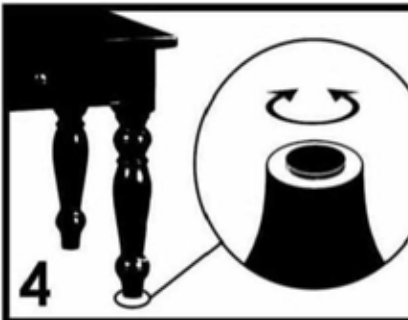

Some furniture comes with height adjustment knobs underneath each leg. To lower or to raise each leg, you need to turn clockwise or counterclockwise, respectively.

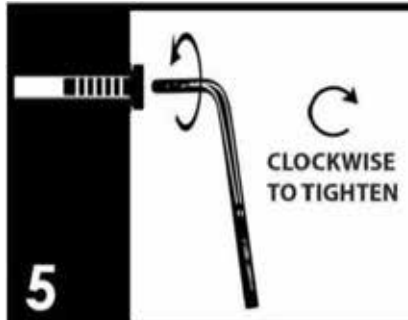

Make sure all parts are properly aligned, then use the appropriate hand tool to completely tighten the bolts or screws. Do not use power tools and do not overtighten.

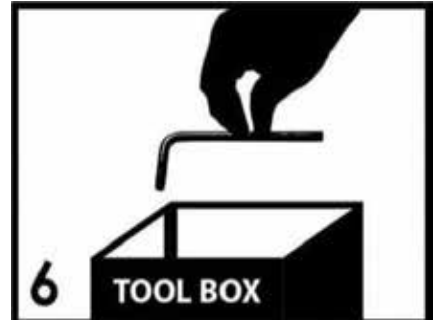

Save the instructions and store the Allen wrench or any supplied tool for later maintenance. After two weeks, check and tighten any loose hardware and repeat again every six months thereafter.

IT IS THE USER'S RESPONSIBILITY TO MAINTAIN THE FURNITURE. THE HARDWARE MAY LOOSEN OVER TIME AND MAY CAUSE THE FURNITURE TO BE WOBBLY AND UNABLE TO SUPPORT ITS INTENDED WEIGHT CAPACITY. THIS MAY LEAD TO COLLAPSE AND MAY CAUSE SERIOUS INJURY.



**FAILURE TO FOLLOW THE GUIDELINES ABOVE MAY RESULT IN INJURY AND/OR PROPERTY DAMAGE.**



Before you begin, please read Page 2 of "Assembly and Care Advice".

And remember, do not tighten until each step is completed or instructed.

### Parts List

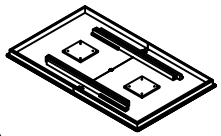

#1 x 1pc  
Table Top

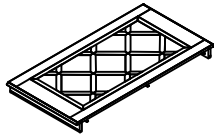

#2 x 1pc  
Leaf

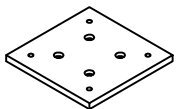

#3 x 2pcs  
Mounting Plate

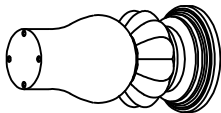

#4 x 2pcs  
Pedestal

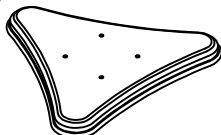

#5 x 2pcs  
Base

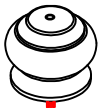

#6 x 6pcs  
Bun Foot

### Hardware List

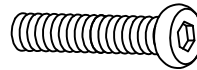

#A x 24pcs  
Bolt Ø5/16"X1-1/2"



#B x 24pcs  
Lock Washer Ø5/16"



#C x 24pcs  
Flat Washer Ø5/16"



#D x 1pc  
Allen Wrench M4



#A x 4PCS  
 #B x 4PCS  
 #C x 4PCS

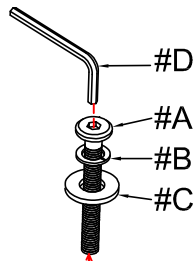

1. Prepare 4 bolt assemblies by first inserting a lock washer (#B) onto the bolt (#A) then a flat washer (#C) onto that same bolt (#A).

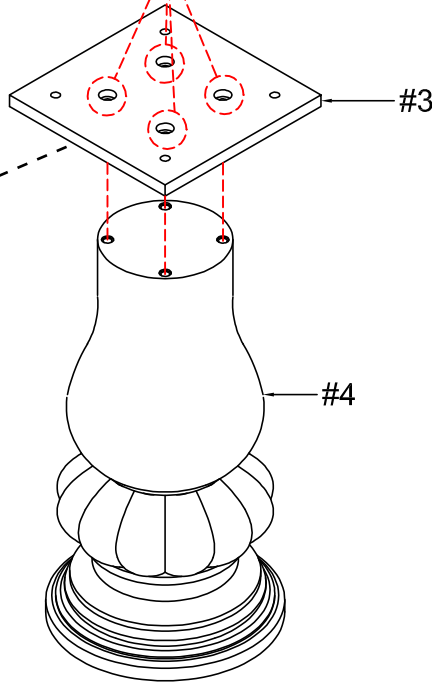

2. Align the Mounting Plate (#3) to the holes along the pedestal (#4), then insert a bolt assembly into each hole. Secure using the Allen wrench.

x 2



#A x 4PCS  
 #B x 4PCS  
 #C x 4PCS

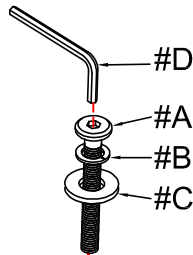

1. Prepare 4 bolt assemblies by first inserting a lock washer (#B) onto the bolt (#A) then a flat washer (#C) onto that same bolt (#A).



2. Align the base (#5) to the holes along the pedestal (#4), then insert a bolt assembly into each hole. Secure using the Allen wrench.

x 2



### Adjusting Level

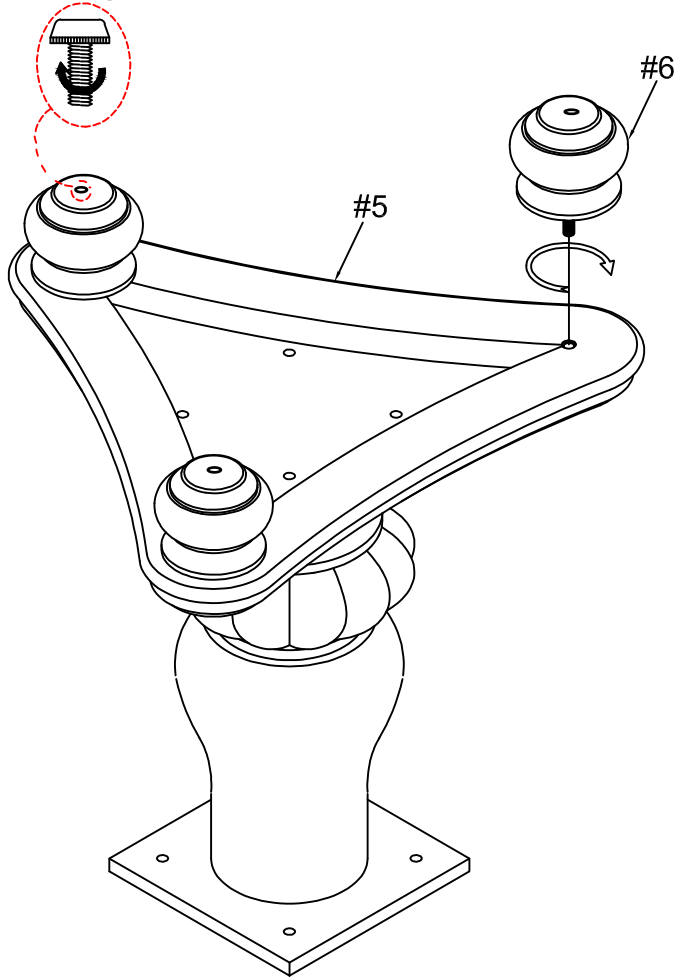

Insert the threaded ends of the bun feet (#6) into the holes along the bottom of the base (#5). Turn right to tighten.

x 2



#A x 8PCS  
#B x 8PCS  
#C x 8PCS

1. Prepare 8 bolt assemblies by first inserting a lock washer (#B) onto the bolt (#A) then a flat washer (#C) onto that same bolt (#A).
2. Align the top of the Mounting Plate (#3) to the holes along the table top (#1), then insert a bolt assembly into each hole and secure.

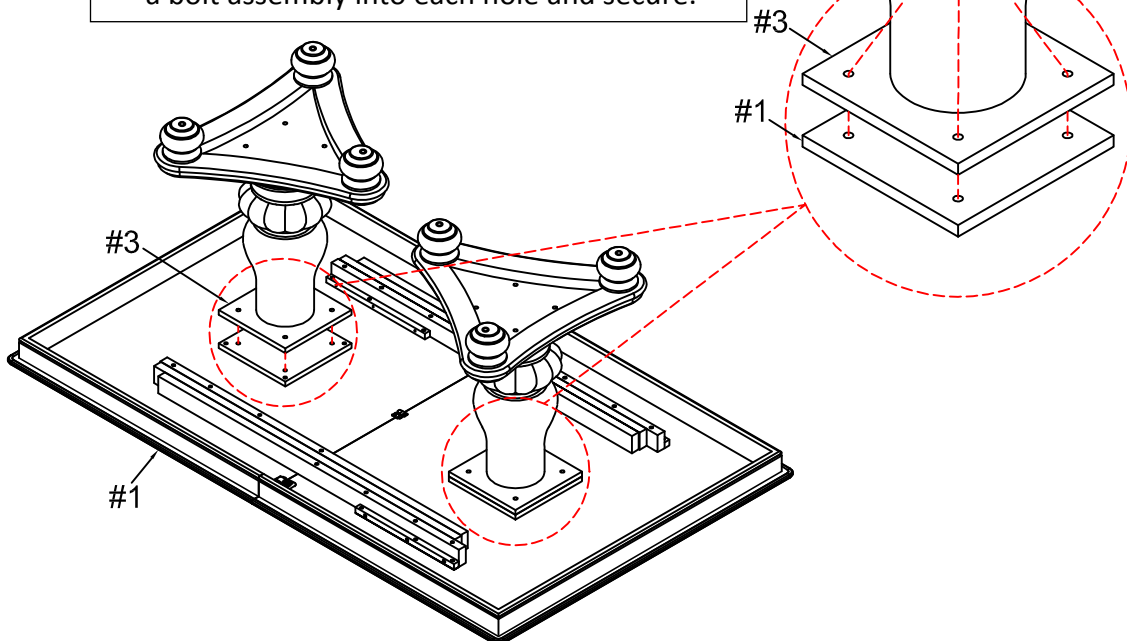
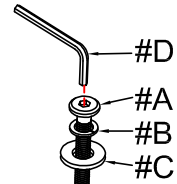



#5

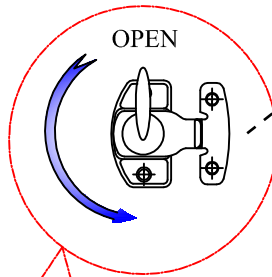

Unlock the latches located along the bottom.

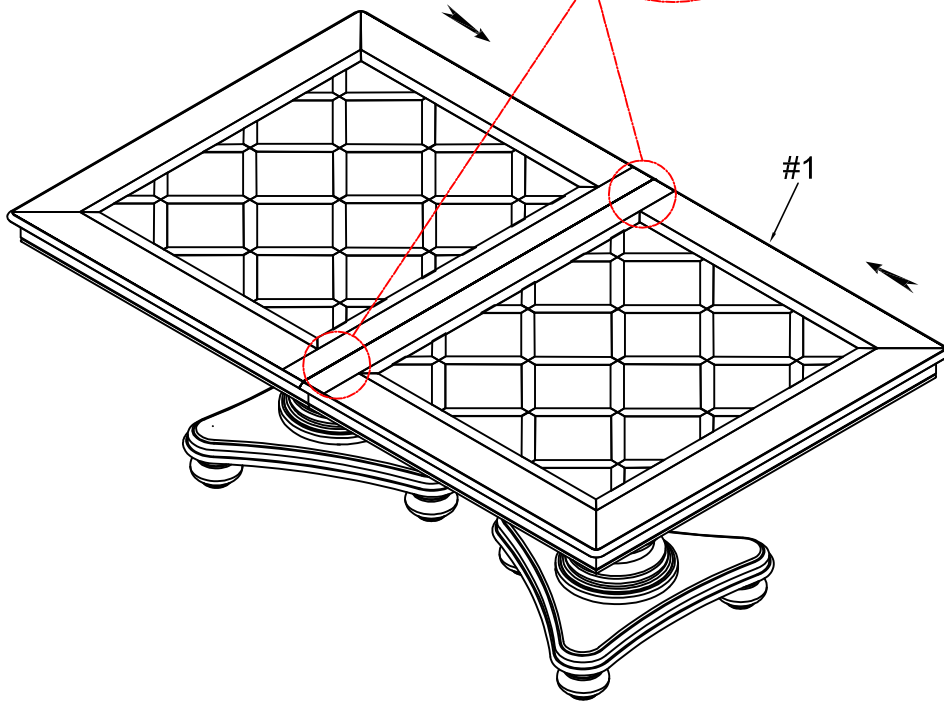

#6

Slide the outer side outward, then place the leaf (#2) onto the rails.

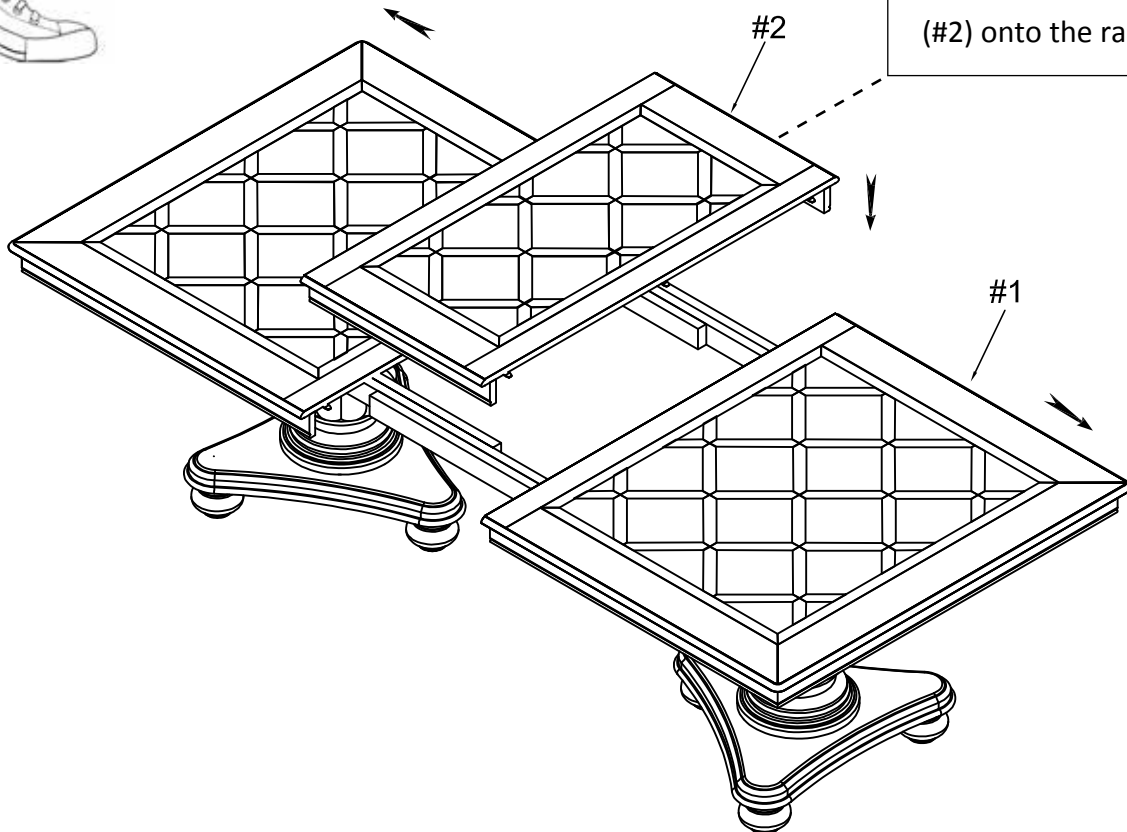

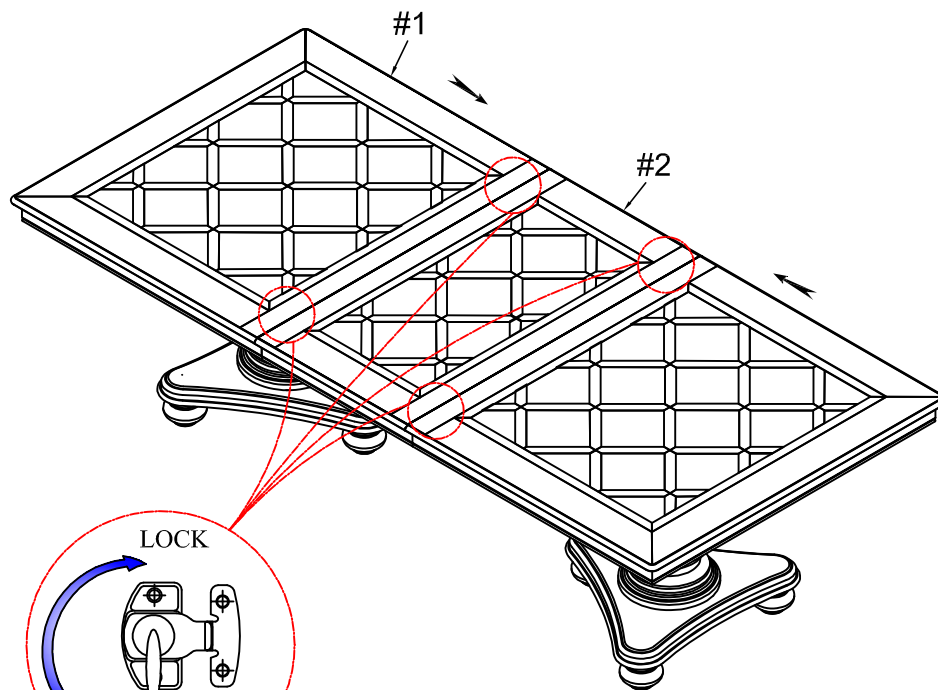

Slide the inward,  
then lock the  
latches along  
the bottom.

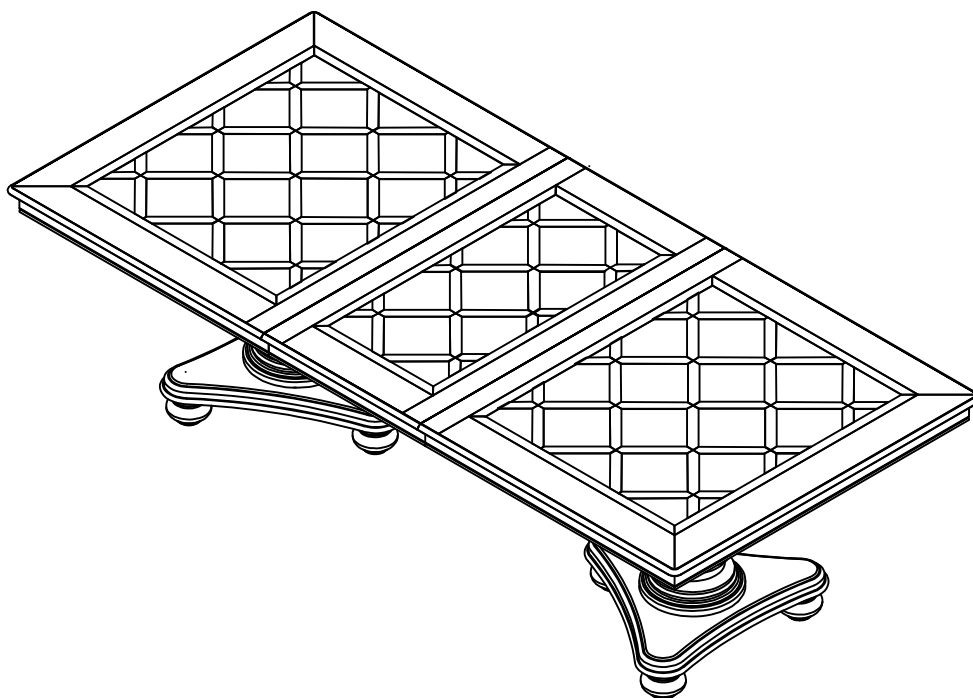

ASSEMBLY IS COMPLETED