

Assembly Instructions

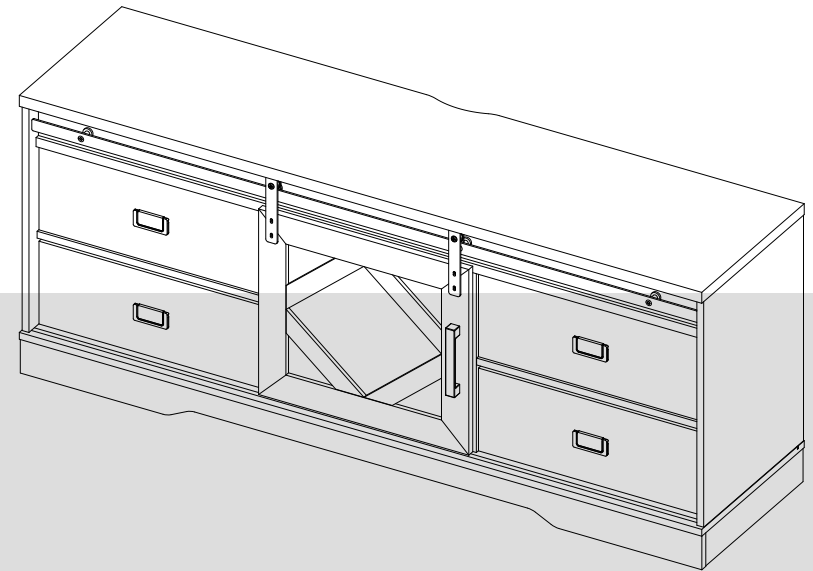

IMPORTANT : please read this manual carefully before beginning assembly of this product. keep this manual for future reference.

WHAT'S IN THE BOX

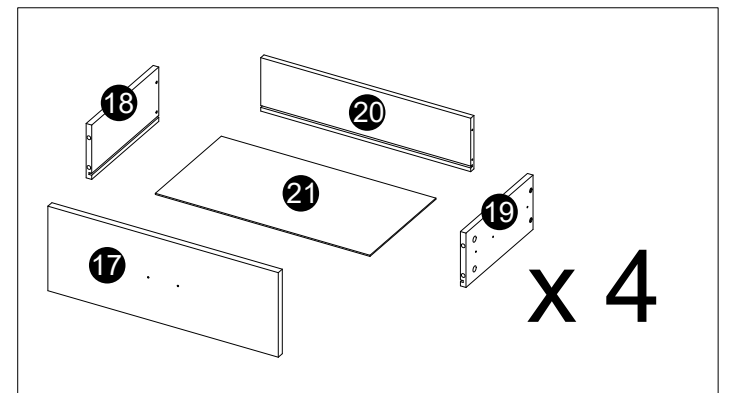
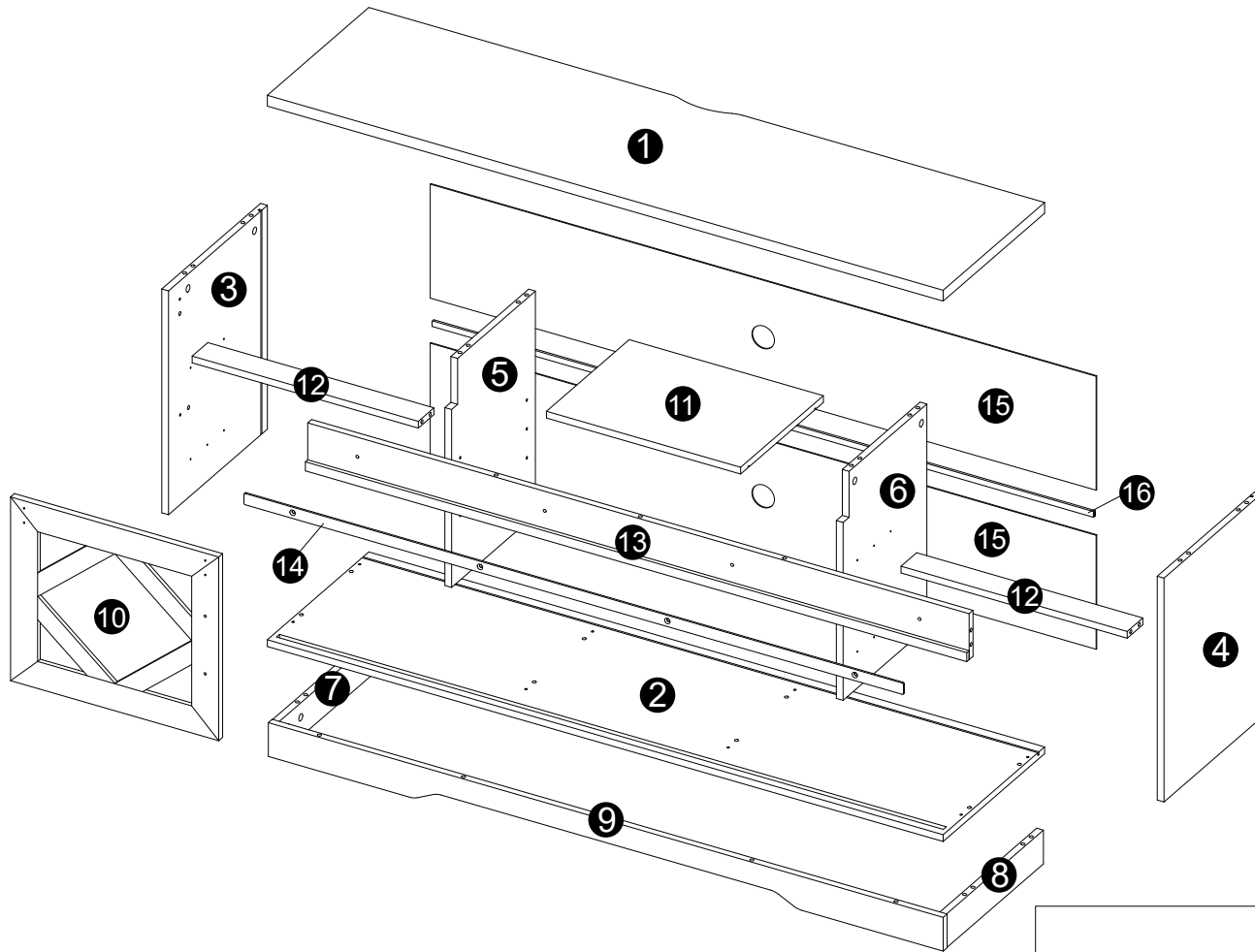

WHAT'S
IN THE BOX

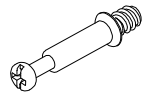

Cam bolt

A x 42

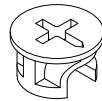

Cam lock

B x 26



Wooden dowel

C x 29



Shelf support pin

D x 4

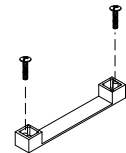

Handle with bolt

E x 1



Plastic wedge
with screw

F x 10

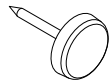

PVC nail with pin

G x 6

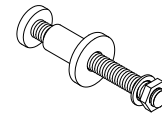

H x 4

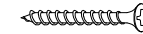

Screw

I x 24



Screw

J x 4



Wrench

K x 1

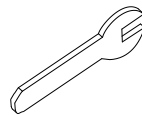

Wrench

L x 1

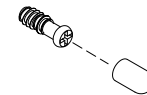

M x 2



Cam lock

N x 16



Screw

O x 48

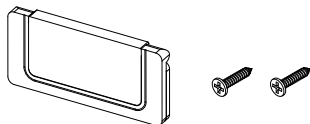

Handle with screws

P x 4

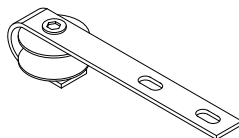

Q x 2

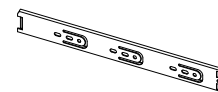

Drawer slider

R x 8

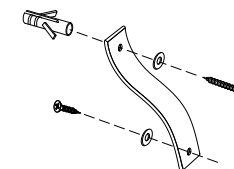

S x 2

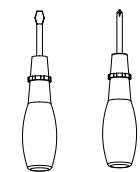

Tools Required
(Not included)

1

INSTALLATION STEPS

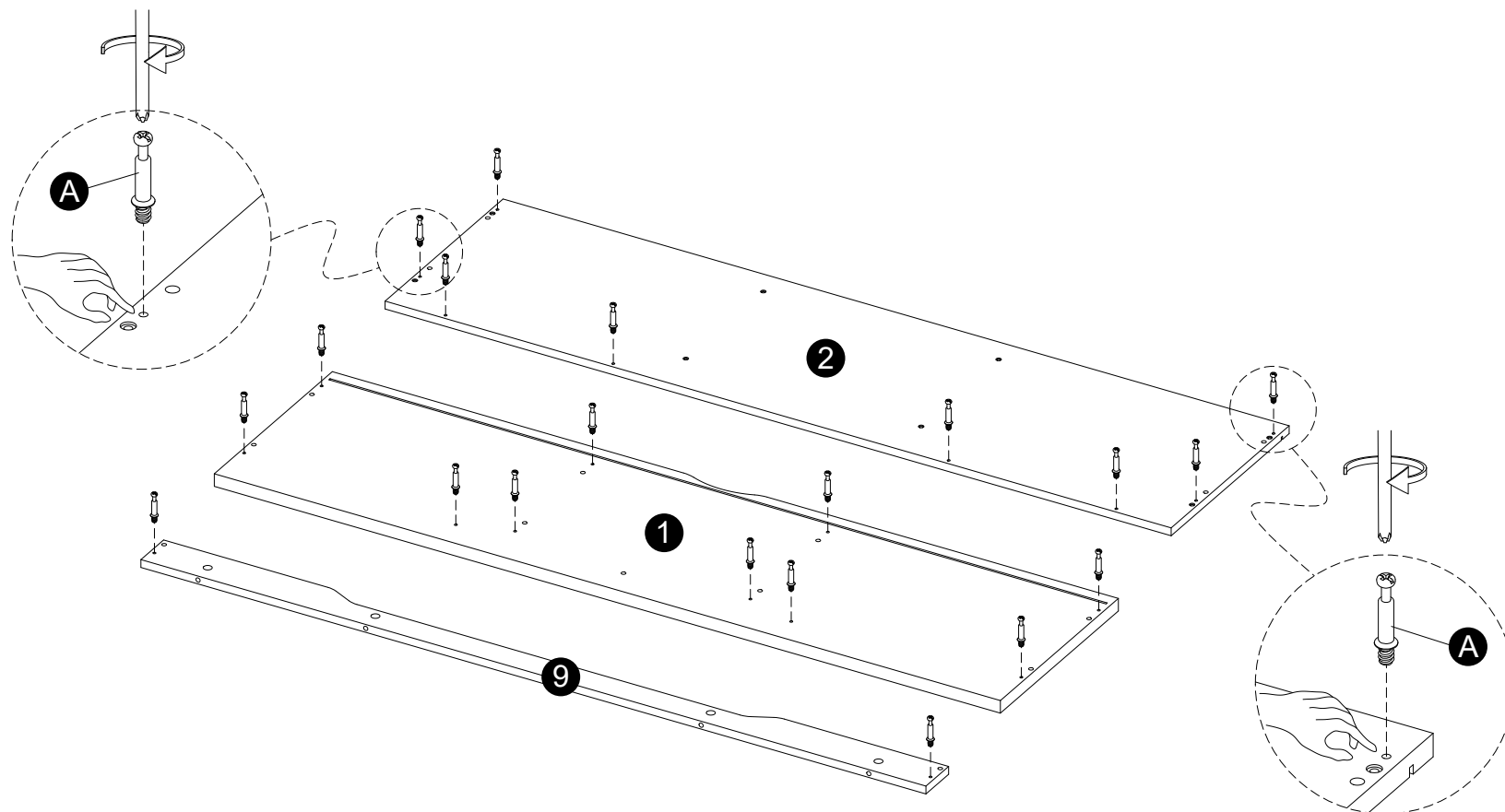
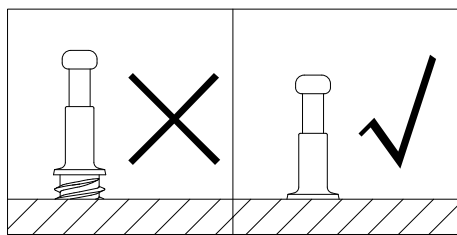

· Screw cam bolts (A) into panels (1,2,9).

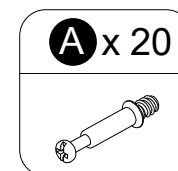

2

INSTALLATION STEPS

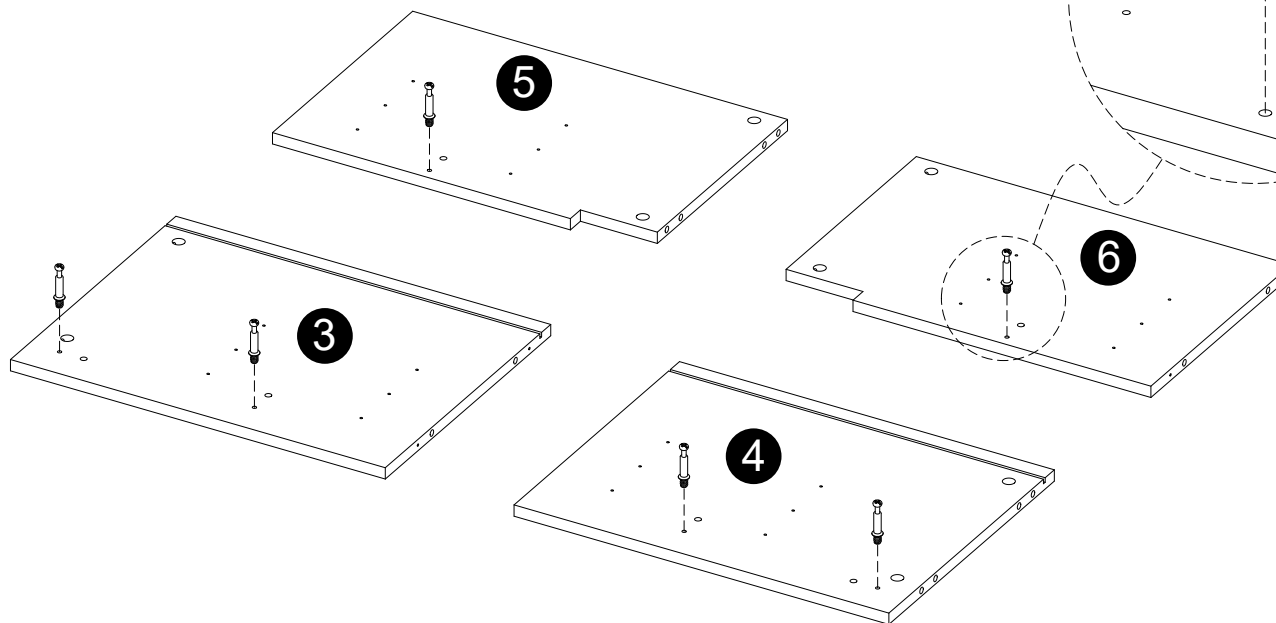
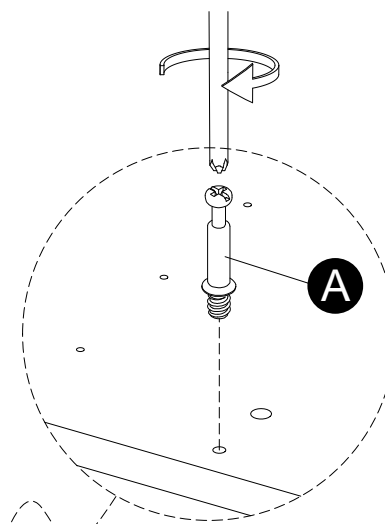
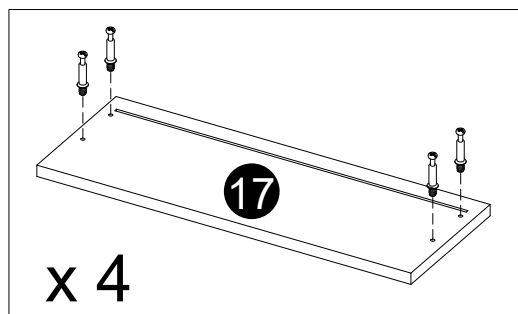
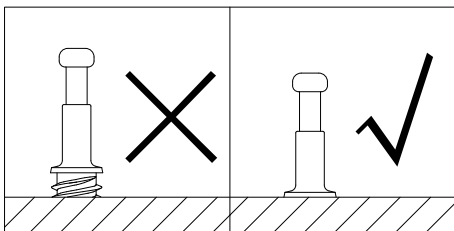

· Screw cam bolts (A) into panels (3,4,5,6,17).

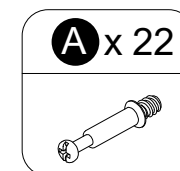

3

INSTALLATION STEPS

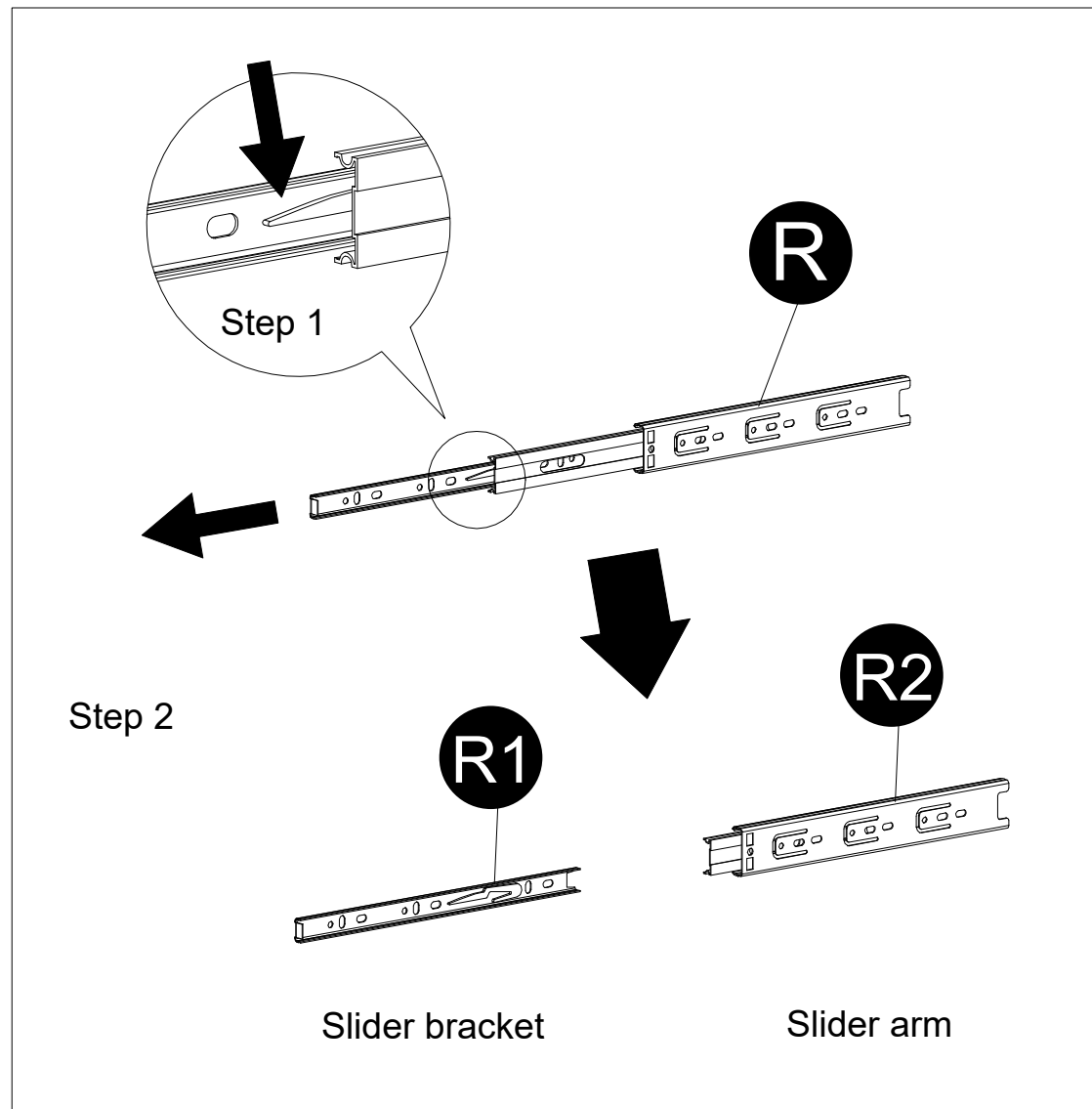

· Separate the slide bracket from the slide arm as per diagram.

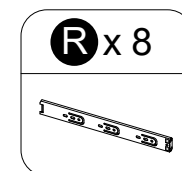

4

INSTALLATION STEPS

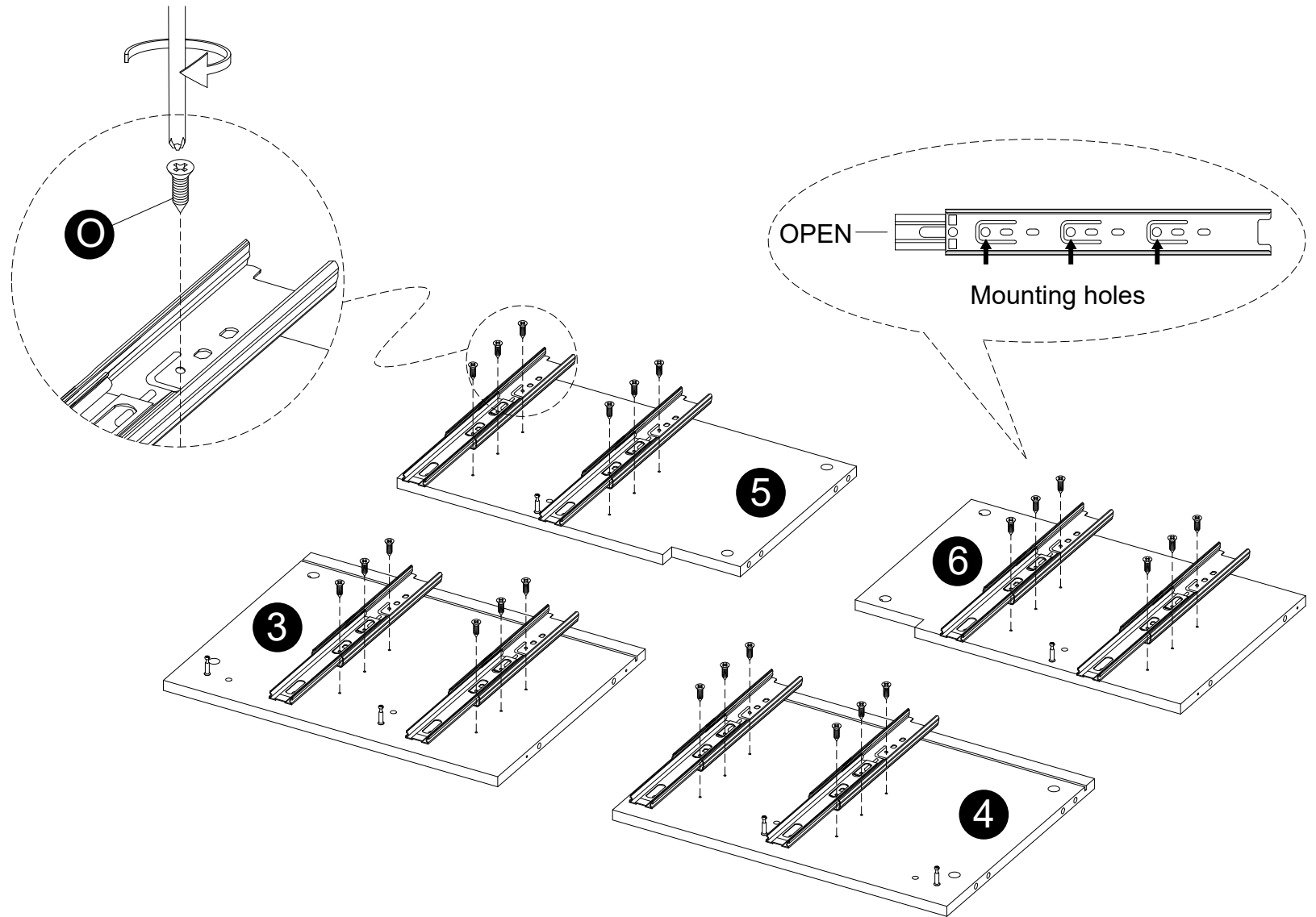

· Attach Slider arms to panels (3,4,5,6) with screws (O) correctly.

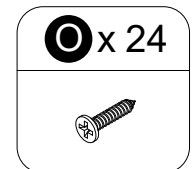

6

INSTALLATION STEPS

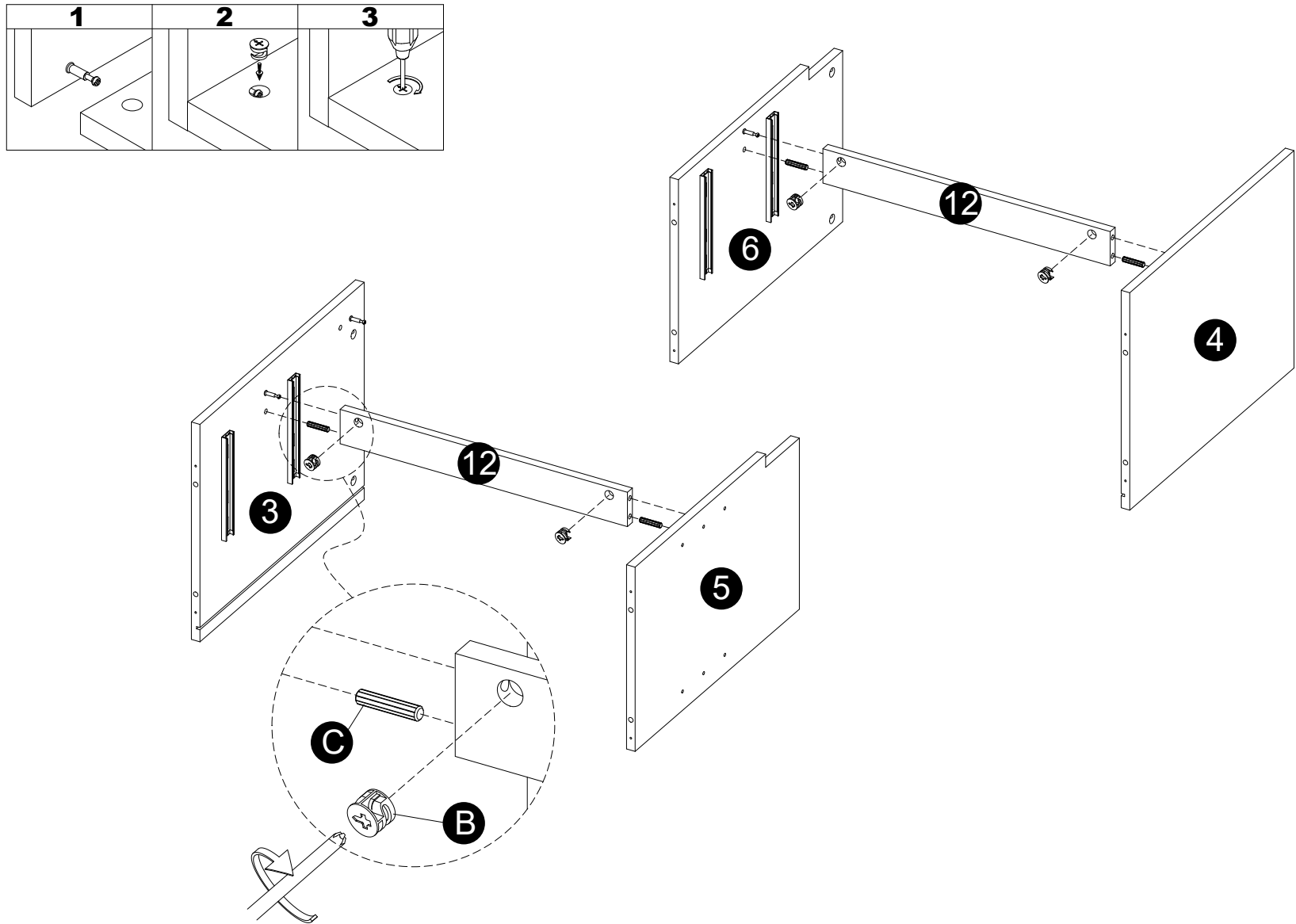

- Insert dowels (C) into panels (12).
- Attach panels (12) to panels (3,4,5,6).
- Insert and secure cam locks (B) to panels (12) to lock it.

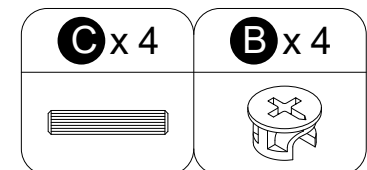

7

INSTALLATION STEPS

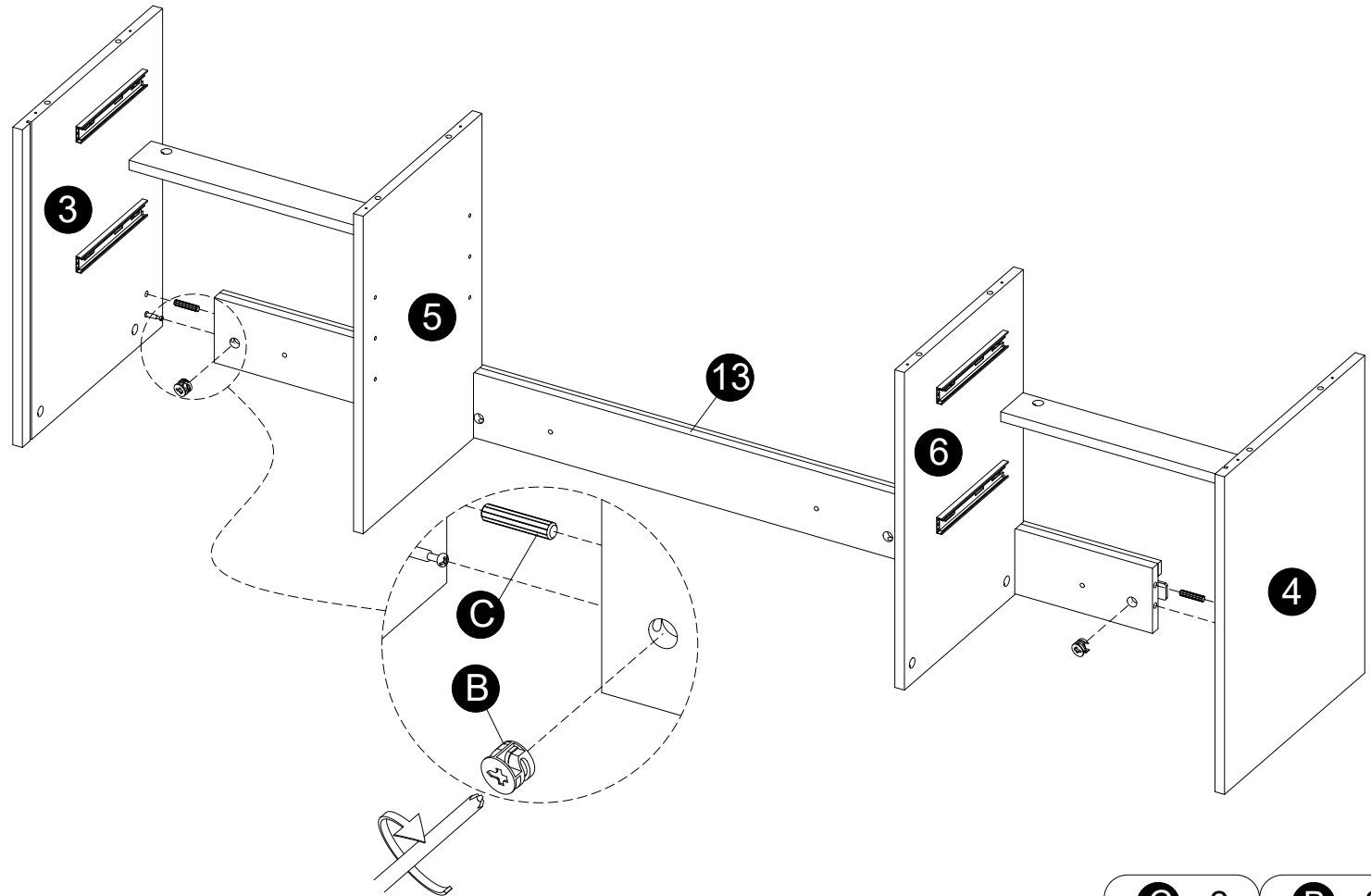
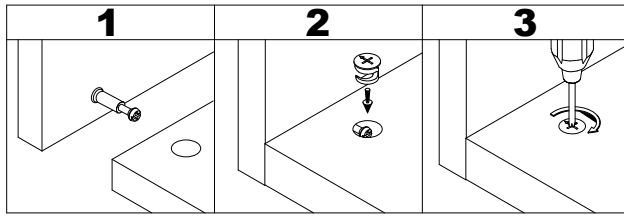

- Insert dowels (C) into part (13).
- Attach part (13) to parts (3,4).
- Insert and secure cam locks (B) to part (13) to lock it.

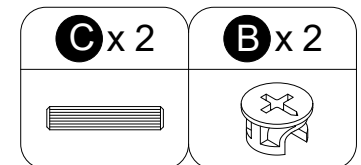

8

INSTALLATION STEPS

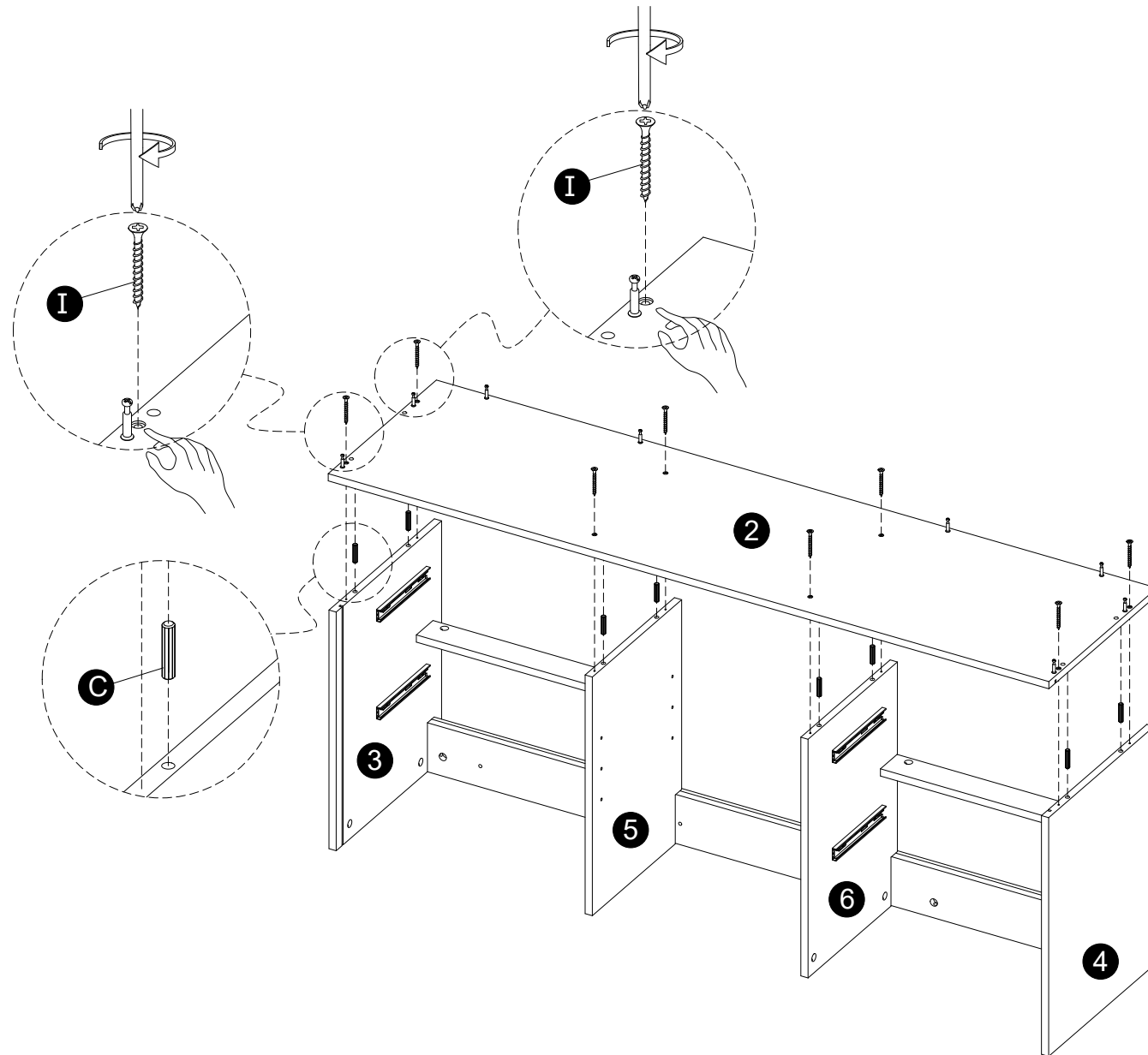

- Insert dowels (C) into panels (3,4,5,6).
- Attach panel (2) to panels (3,4,5,6) with screws (I).

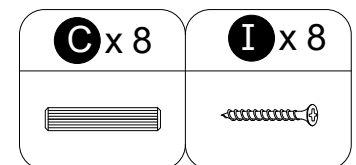

9

INSTALLATION STEPS

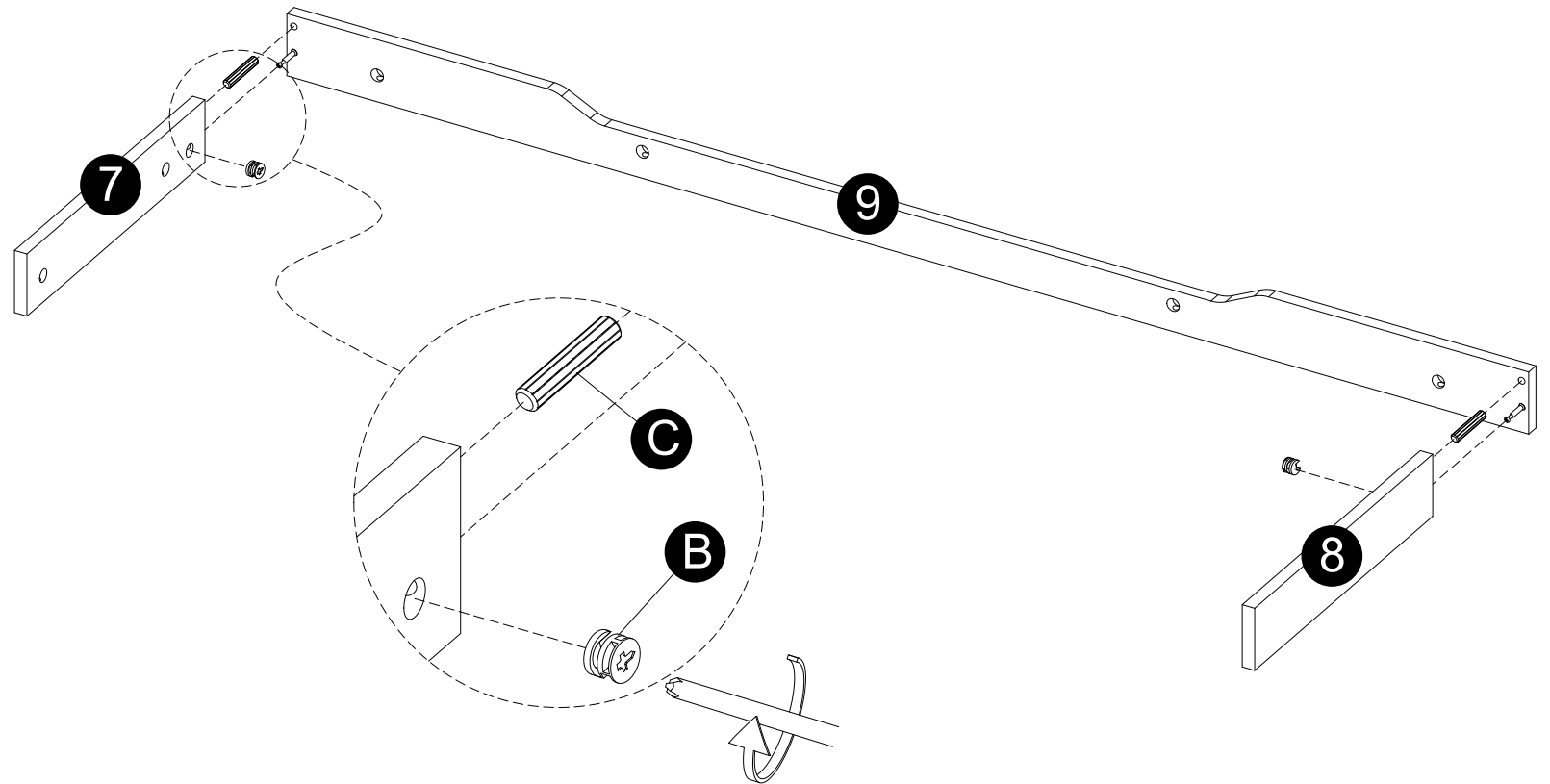
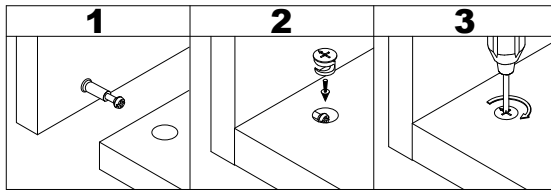

- Insert dowels (C) into panels (7,8).
- Attach panel (9) to panels (7,8).
- Insert and secure cam locks (B) to panels (7,8) to lock it.

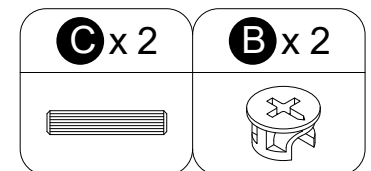

10

INSTALLATION STEPS

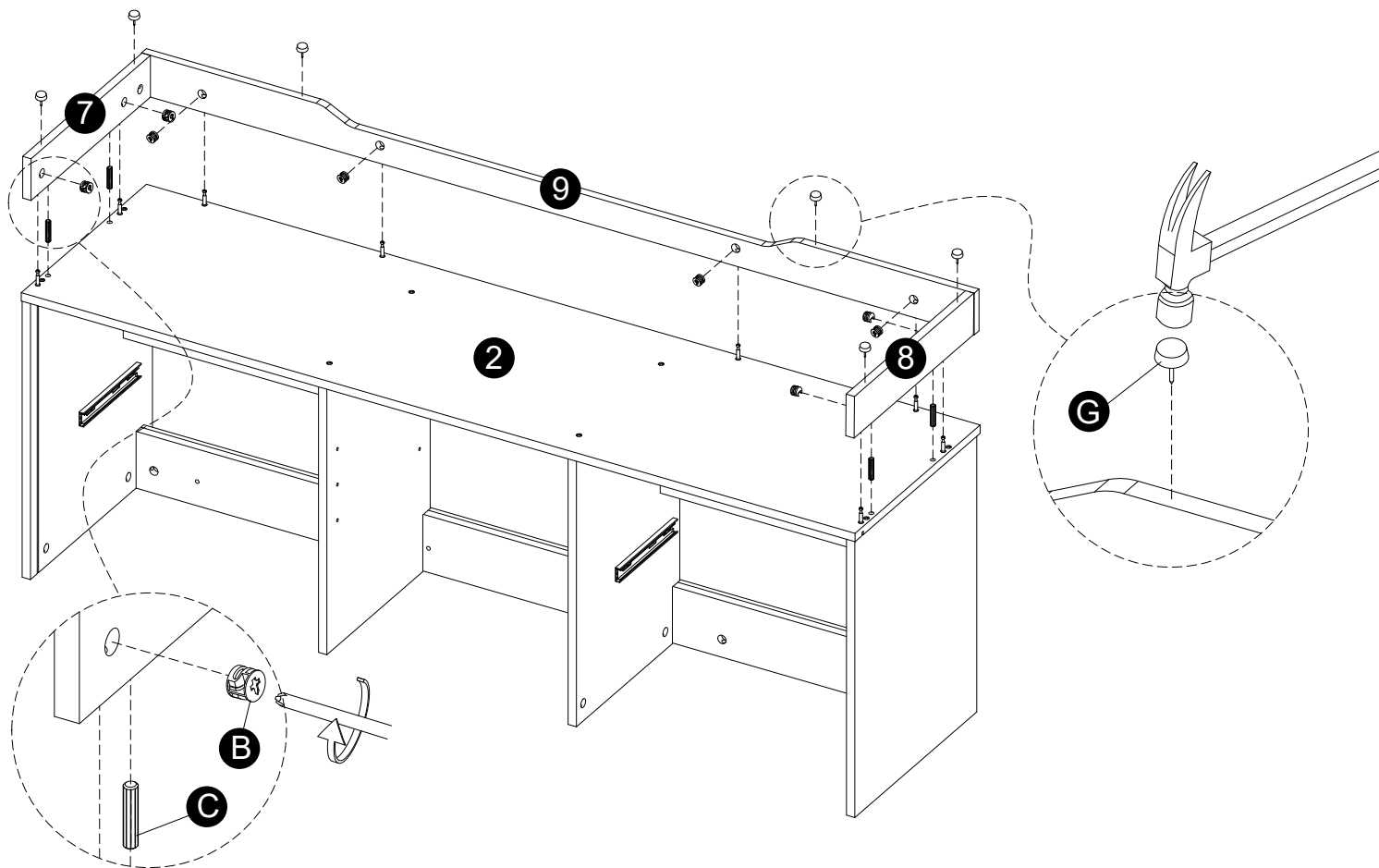
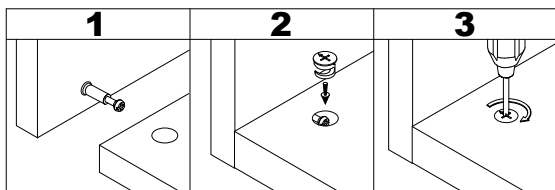

- Insert dowels (C) into panels (2).
- Attach panels (7,8,9) to part (2).
- Insert and secure cam locks (B) to panels (7,8,9) to lock it.
- Knock pins (G) into panels (7,8,9).

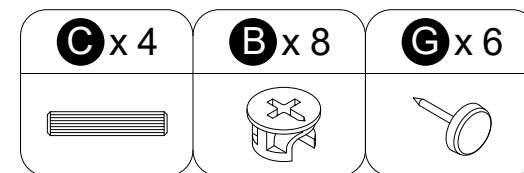

11

INSTALLATION STEPS

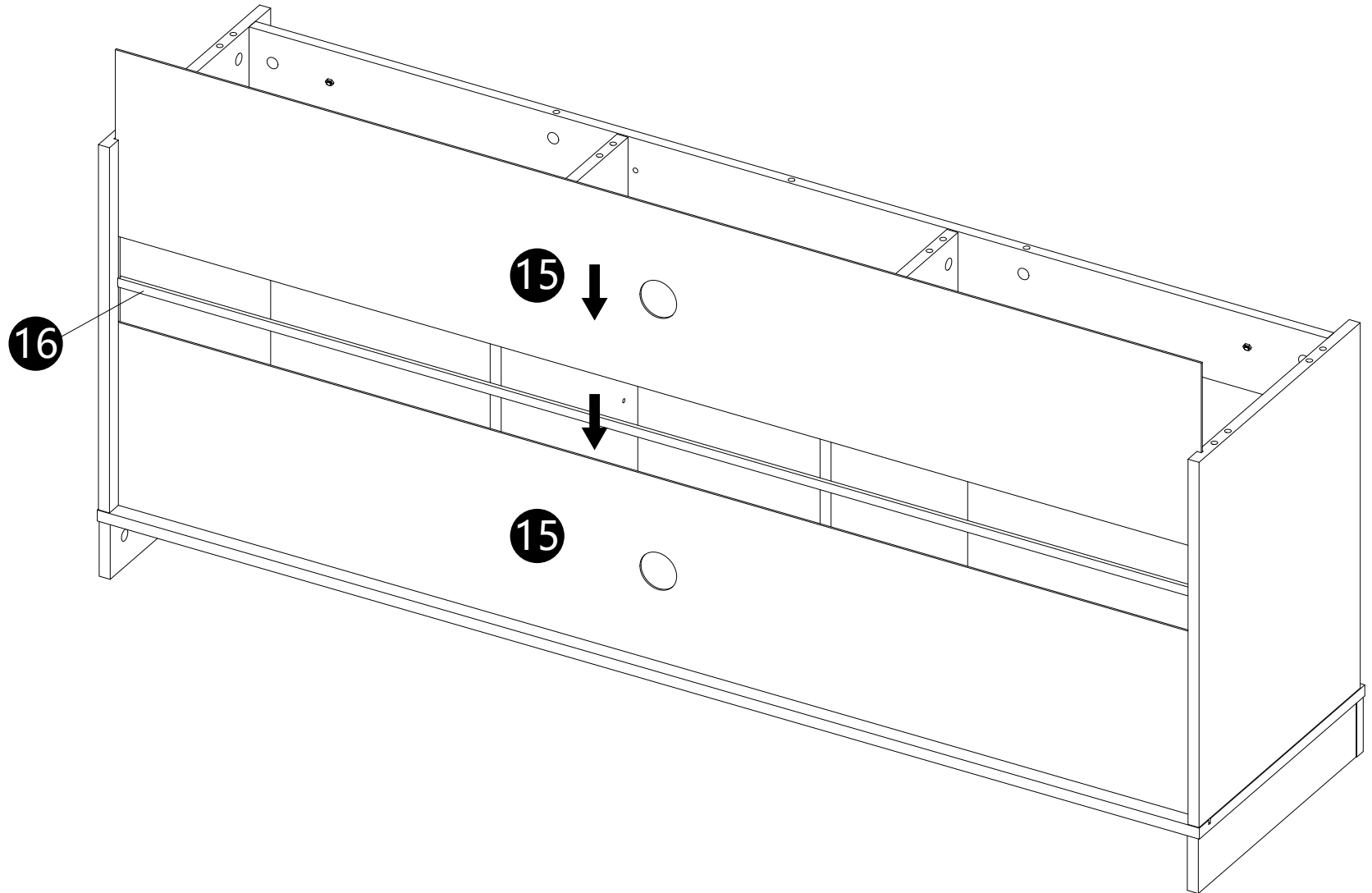

· Carefully slide part (15,16) into place along the back of the assembly.

12

INSTALLATION STEPS

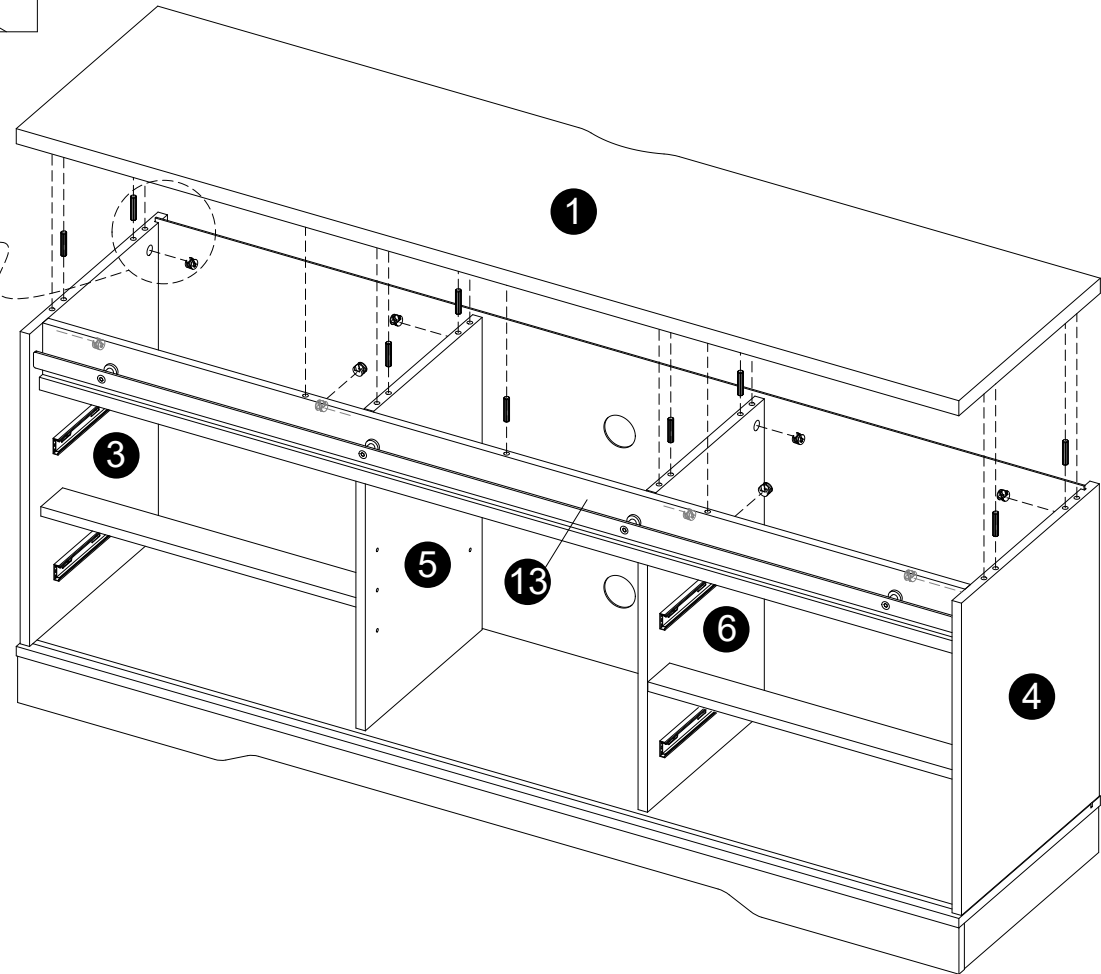
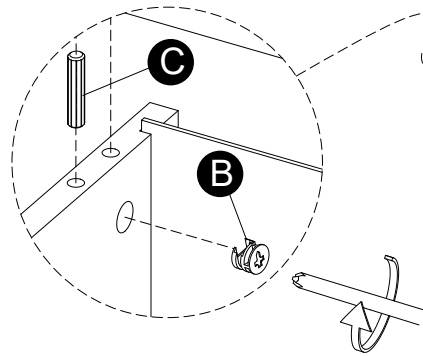
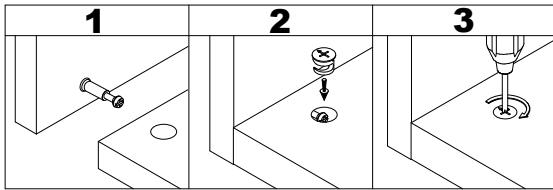

- Insert dowels (C) into panels (3,4,5,6,13).
- Attach panel (1) to panels (3,4,5,6,13).
- Insert and secure cam locks (B) to panels (3,4,5,6,13) to lock it.

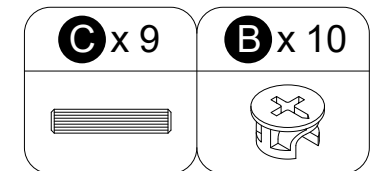

13

INSTALLATION STEPS

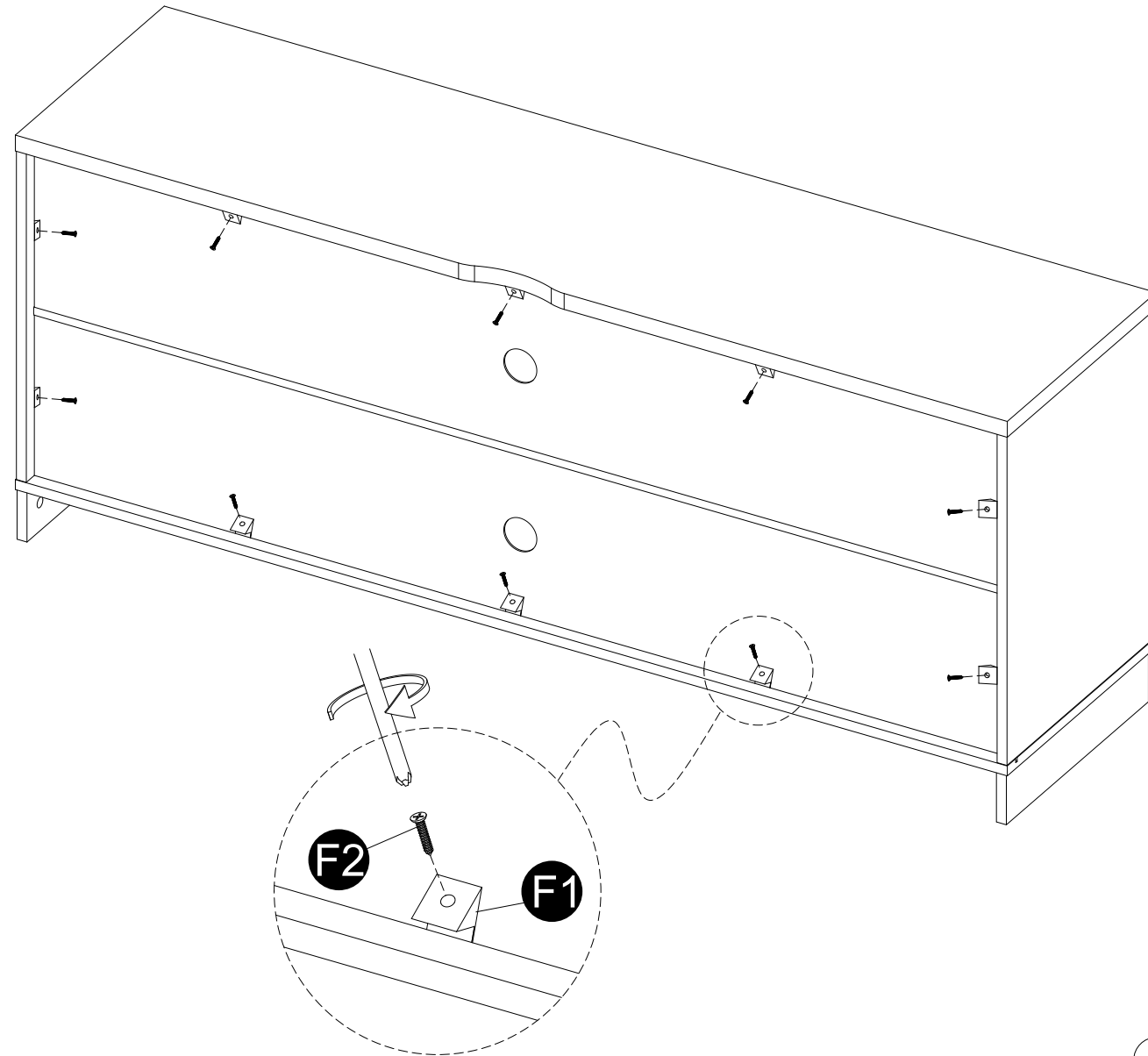

· Secure parts (F1) with screws (F2) as per diagram.

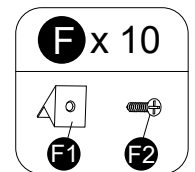

14

INSTALLATION STEPS

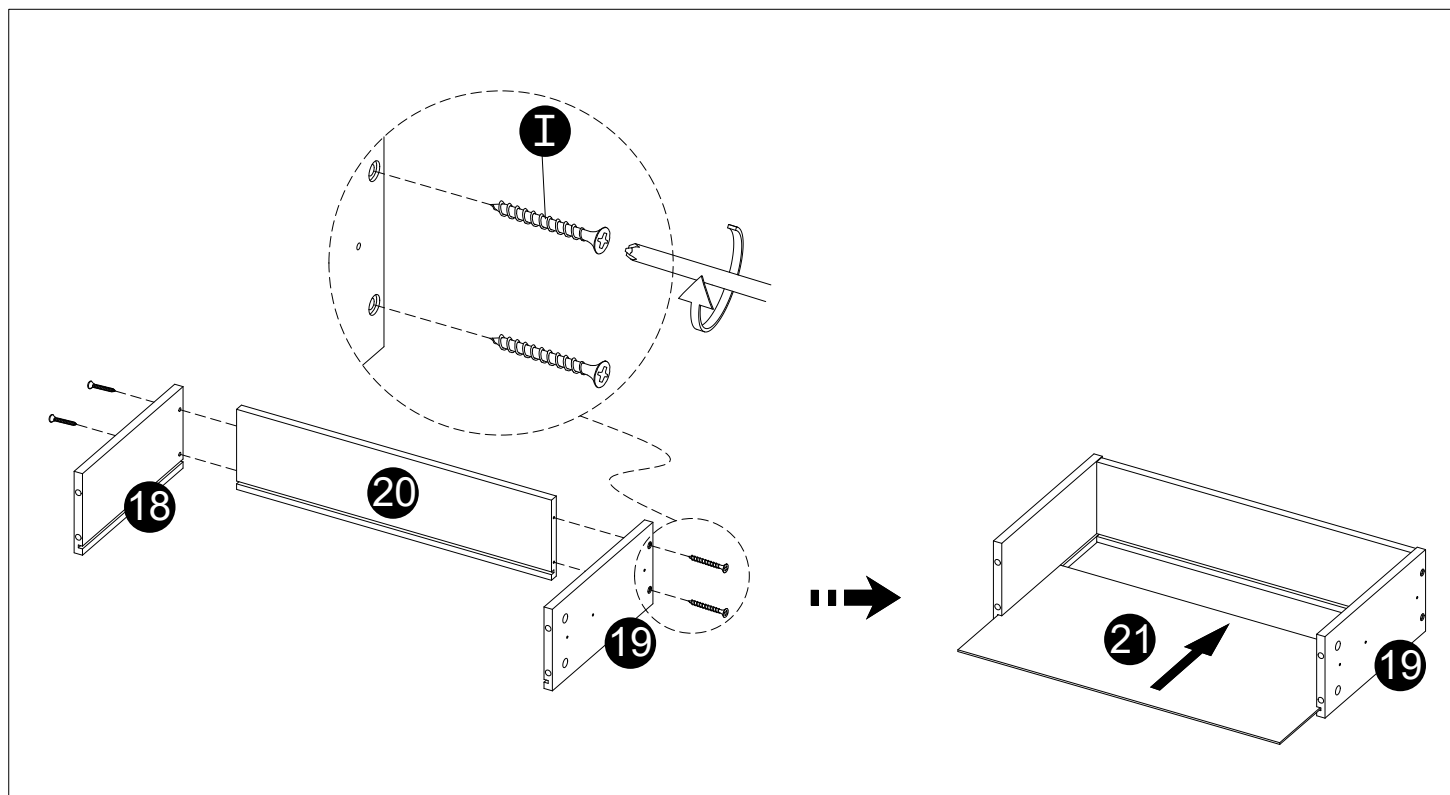

x 4

- Attach panels (18,19) to panel (20) with screws (I).
- Carefully slide panel (21) into place along the bottom of the assembly.

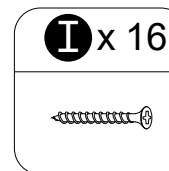

15

INSTALLATION STEPS

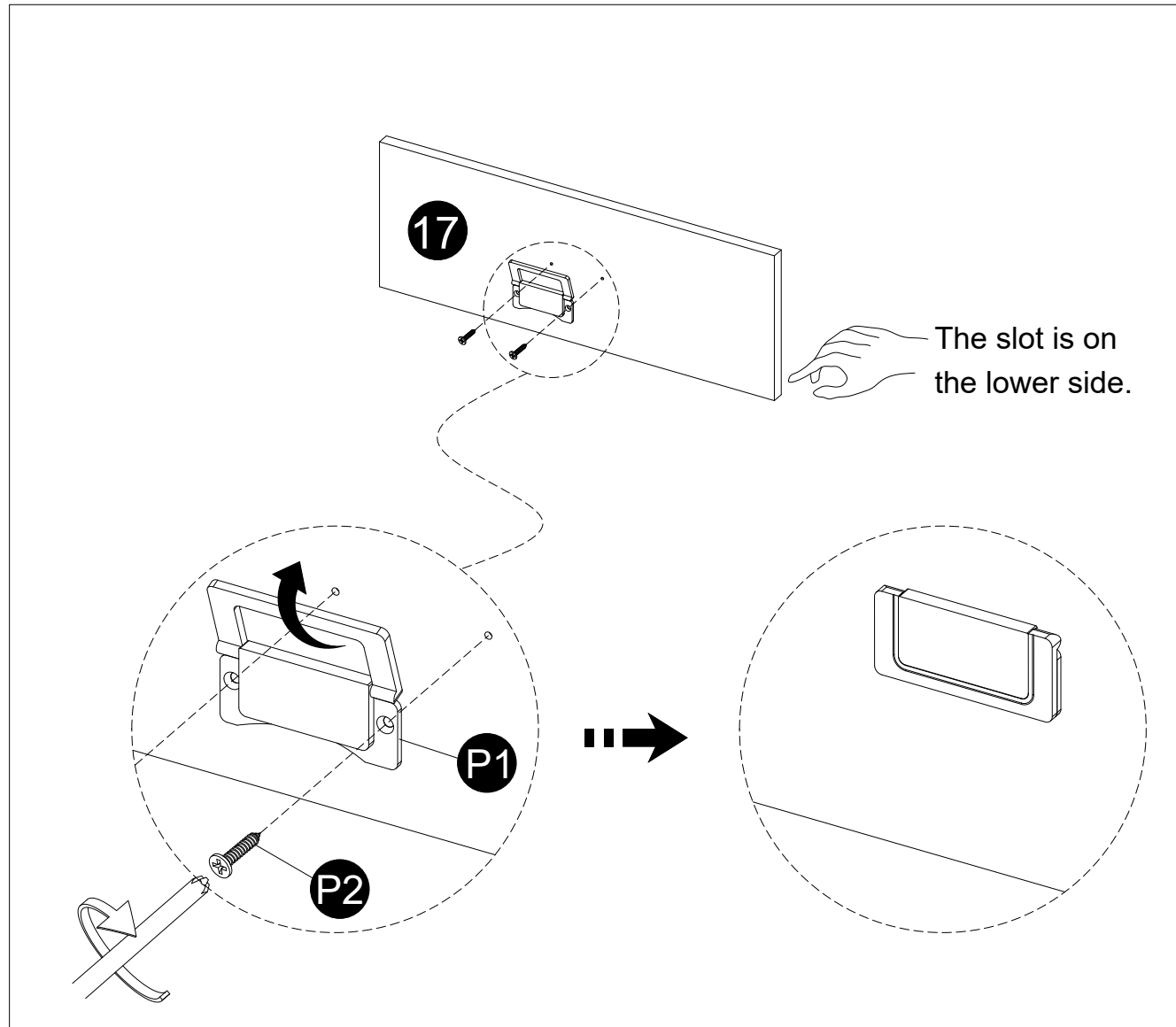

x 4

· Attach parts (P1) to panels (17) with screws (P2).

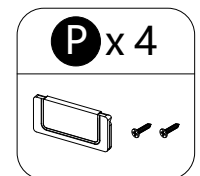

16

INSTALLATION STEPS

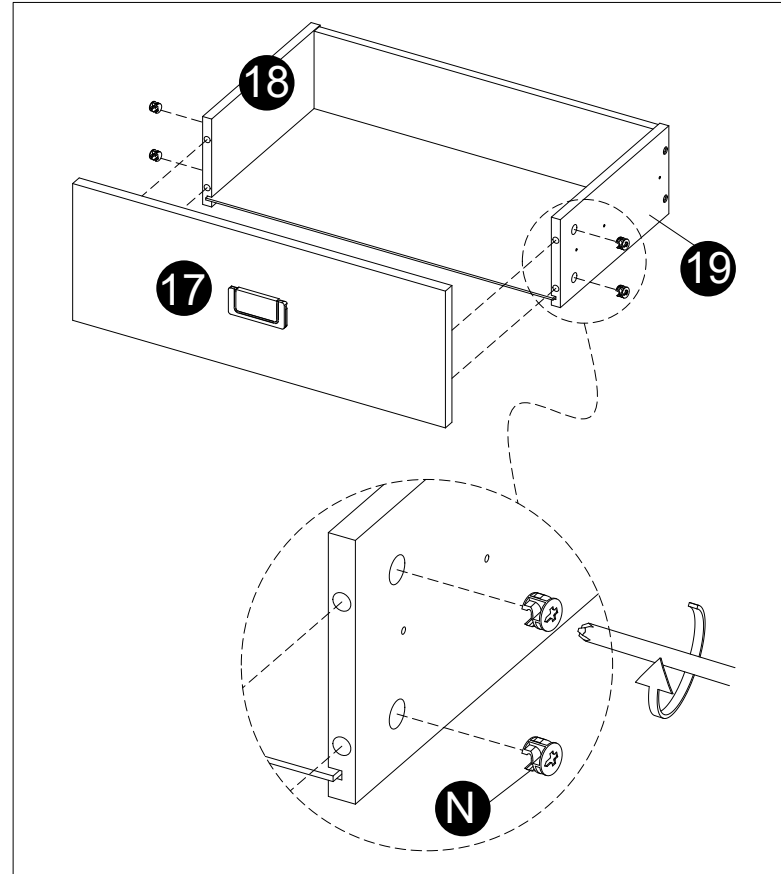
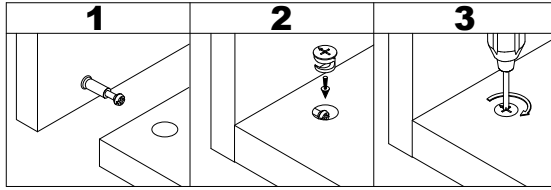

x 4

- Attach part (17) to panels (18,19).
- Insert and secure cam locks (N) to panels (18,19) to lock it.

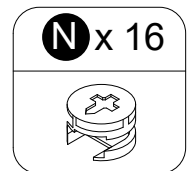

17

INSTALLATION STEPS

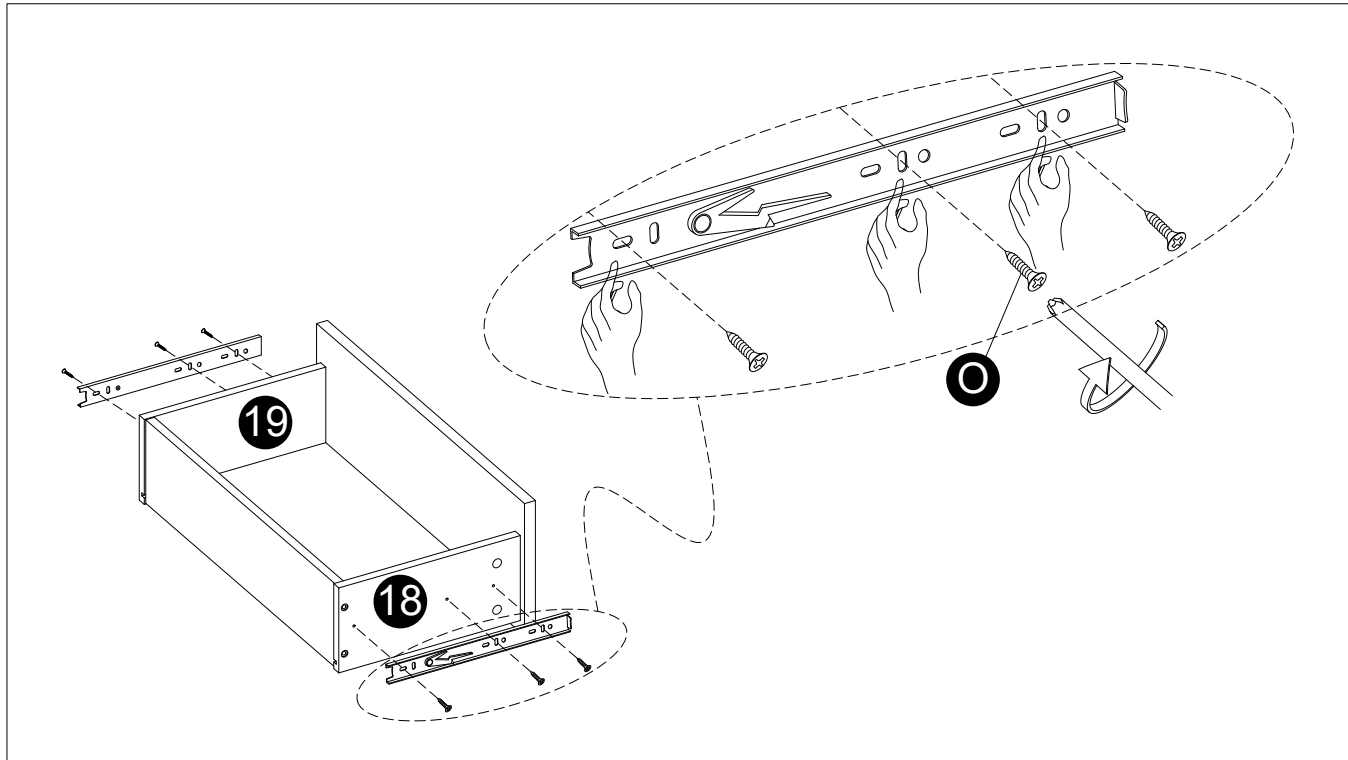

x 4

· Attach slider brackets to panels (18,19) with screws (O) correctly.

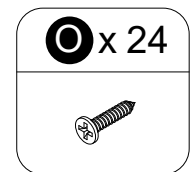

18

INSTALLATION STEPS

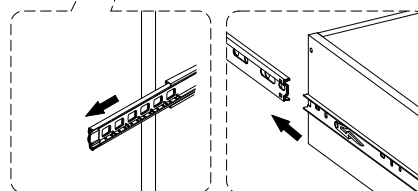
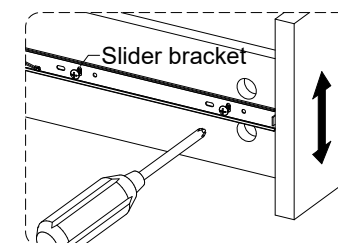
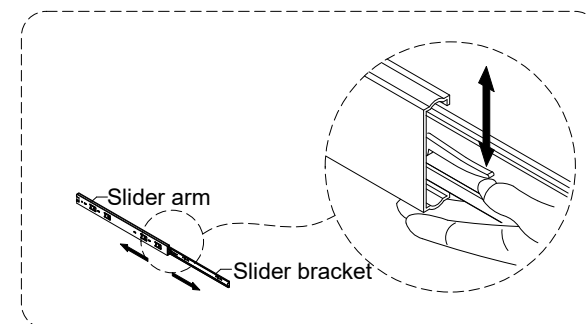
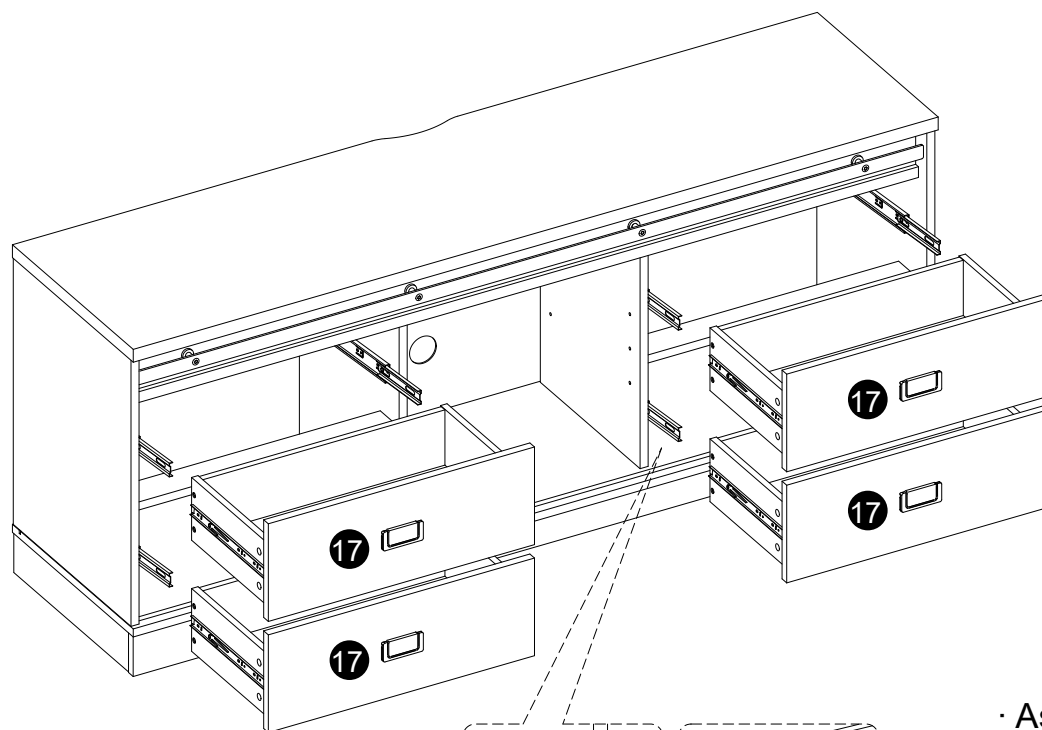

· Assembled the drawers as per diagram

Note :
If the drawer does not go in smoothly.
Press or lift the plastic release lever.
Pull out the slider bracket from
the slider arm.
Loosen the screws (O) on slider brackets,
You can adjust up or down by a few mm.
Then tighten back up.
Finally re-assembled the drawer until
they were going in smoothly well.

19

INSTALLATION STEPS

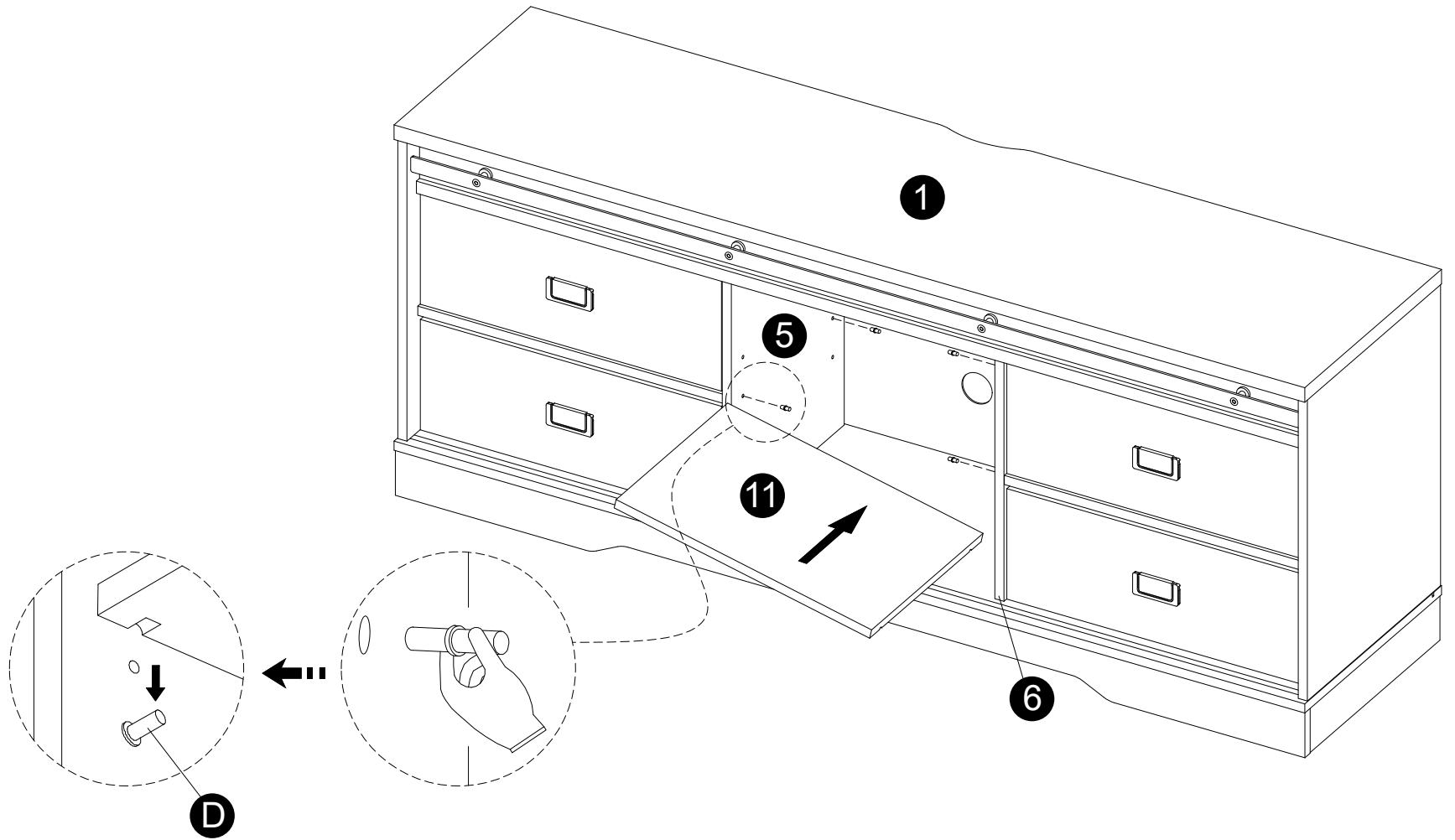

· Attach panel (11) to panels (5,6) using parts (D).

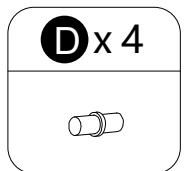

20

INSTALLATION STEPS

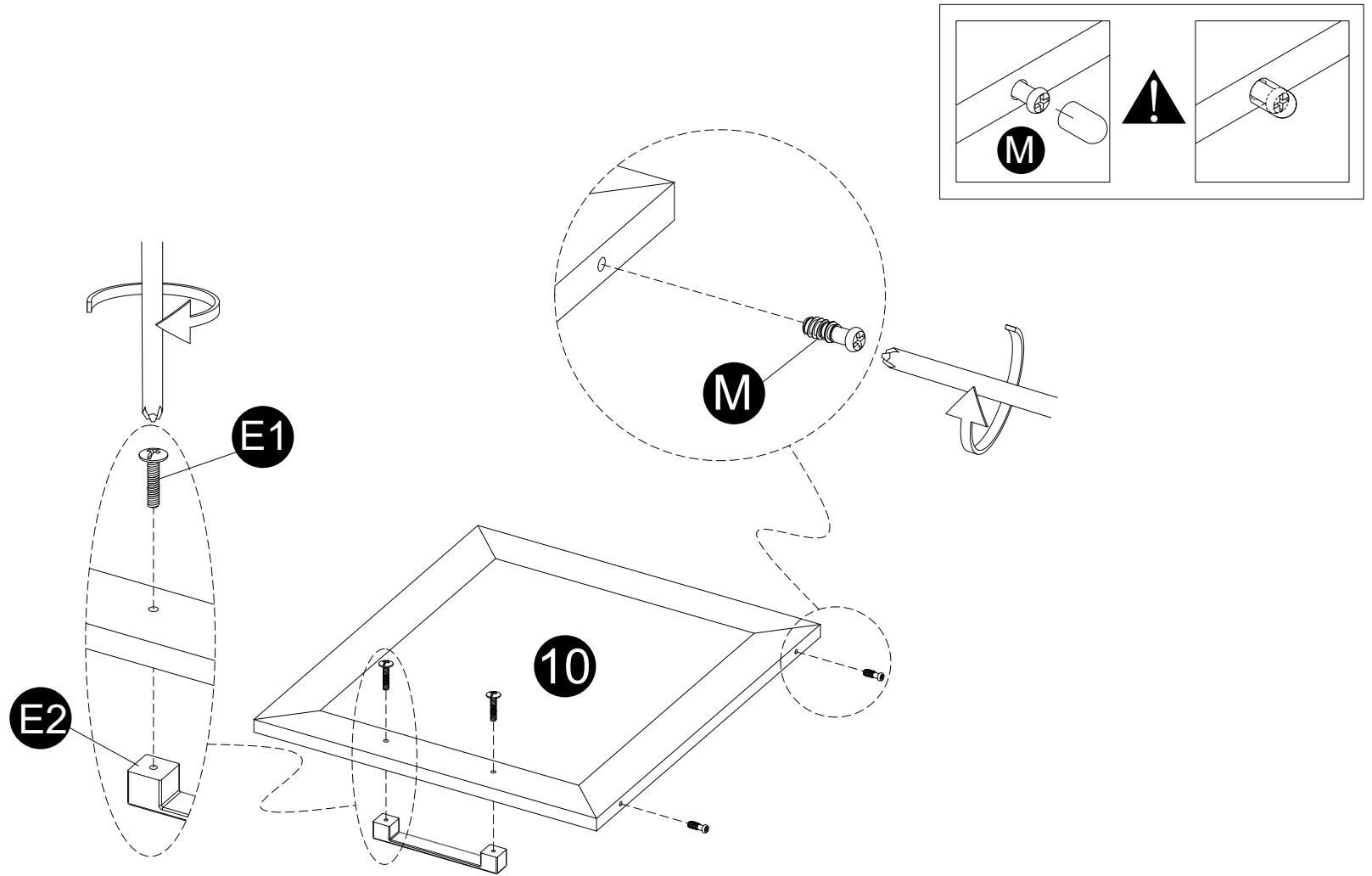

- Attach part (M) to panel (10) correctly.
- Attach part (E2) to panel (10) with bolts (E1) correctly.

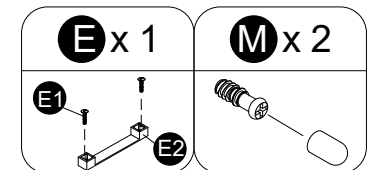

21

INSTALLATION STEPS

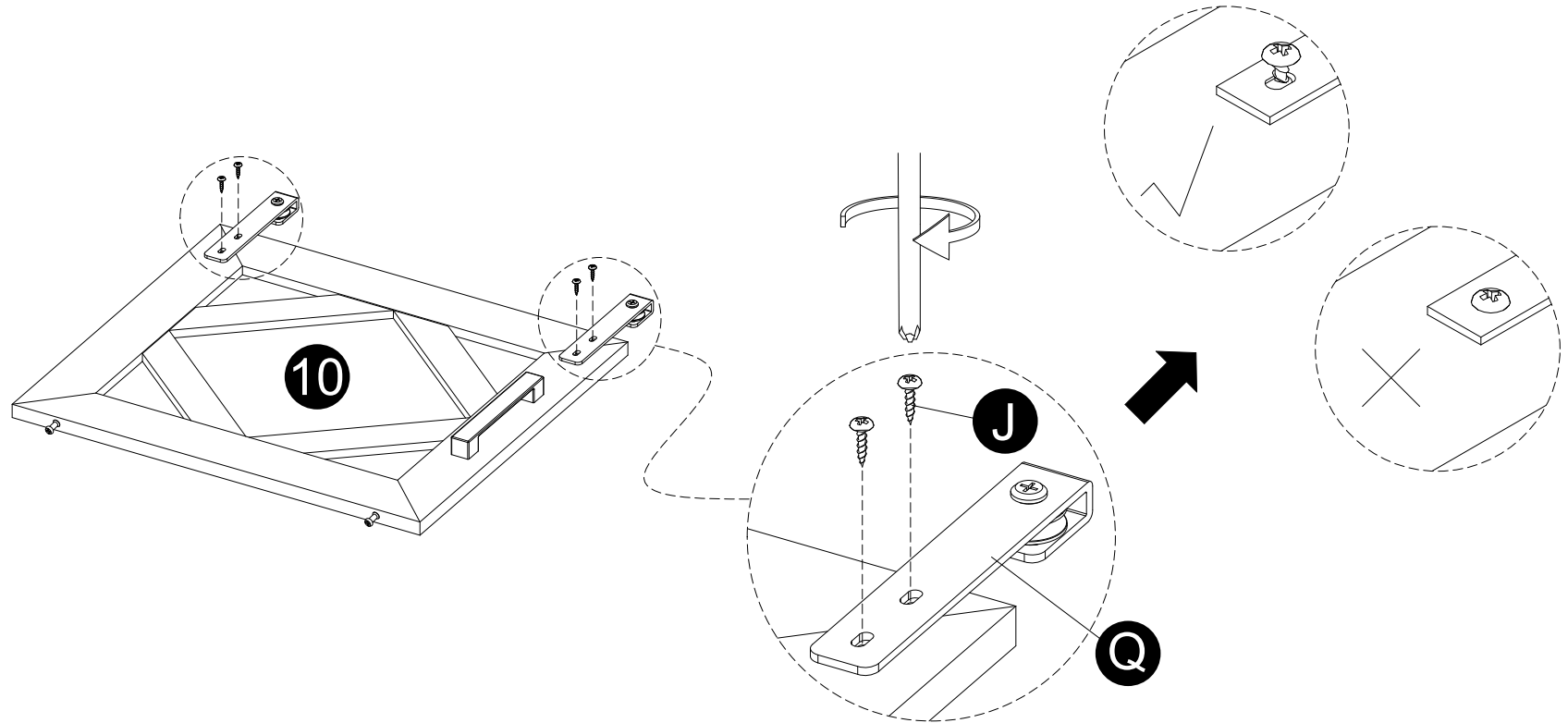

· Attach parts (Q) to panel (10) with screws (J) correctly, but don't fix the screws tight.

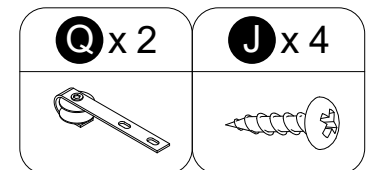

22

INSTALLATION STEPS

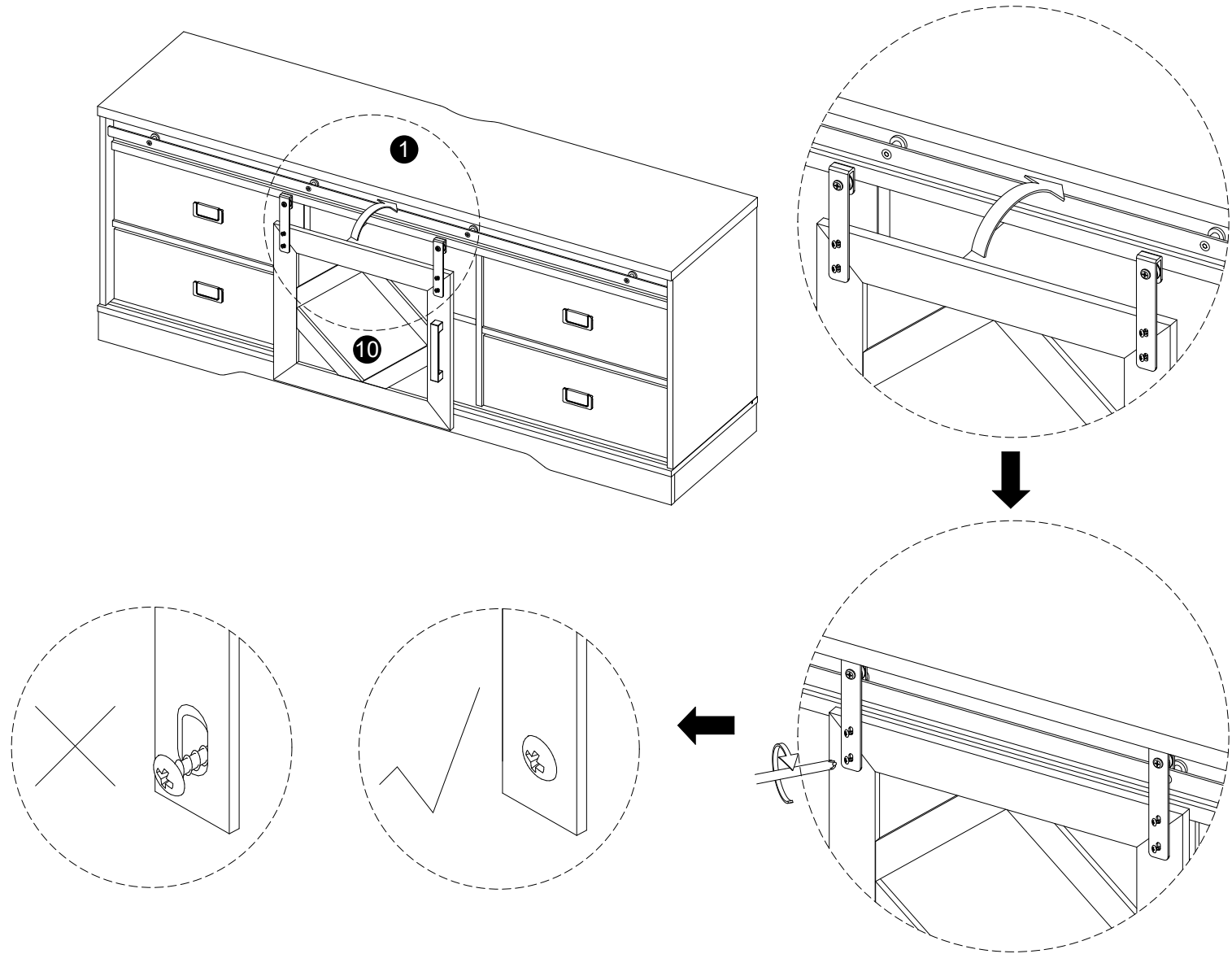

- Installing the door (10) in position, adjust door height and leveling, then fix screws tight and slide door (10) into designated area.

23

INSTALLATION STEPS

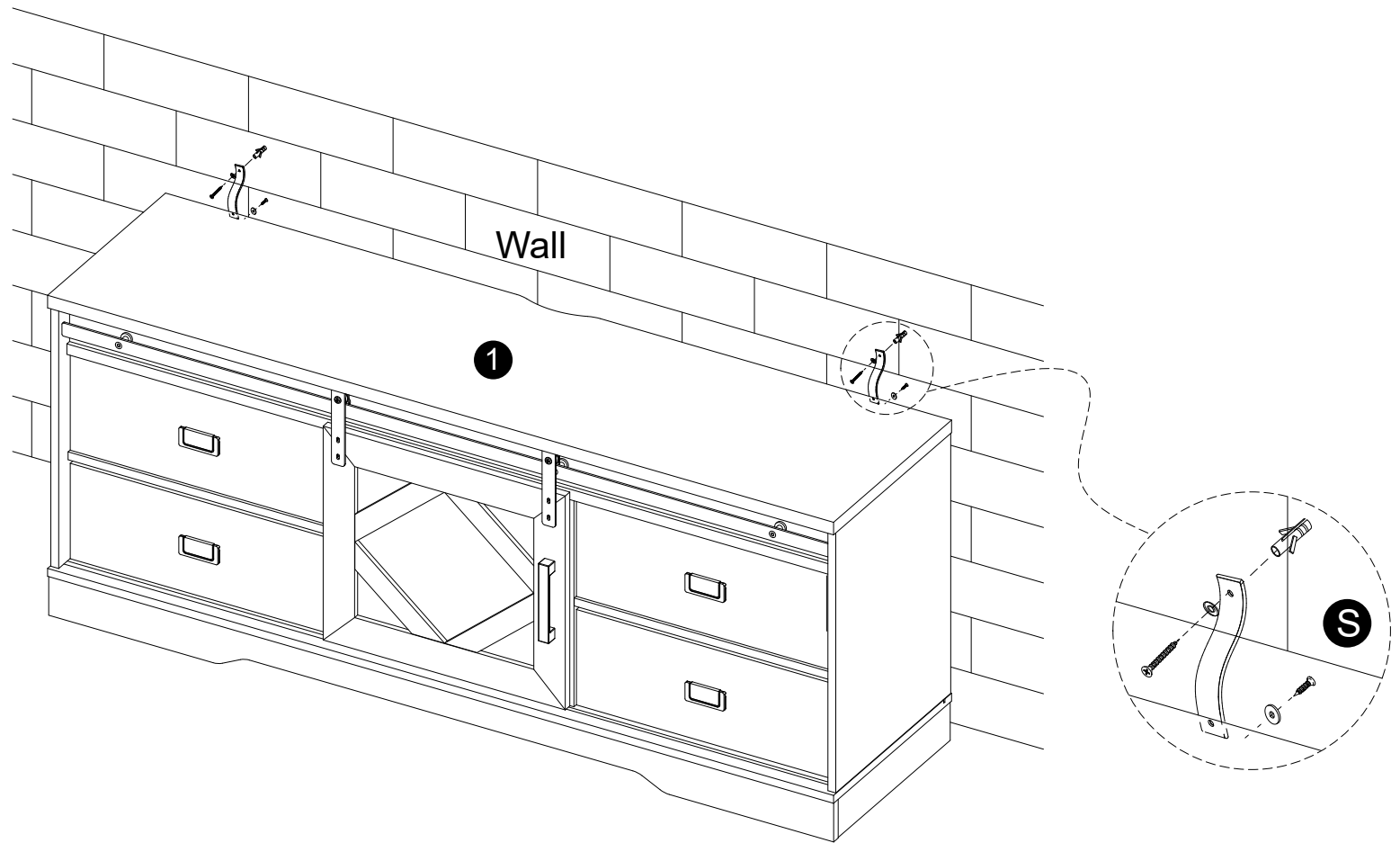

· To prevent TV cabinet from toppling, install the parts (S).

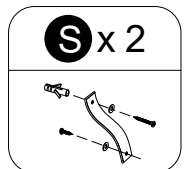

Assembly Instructions

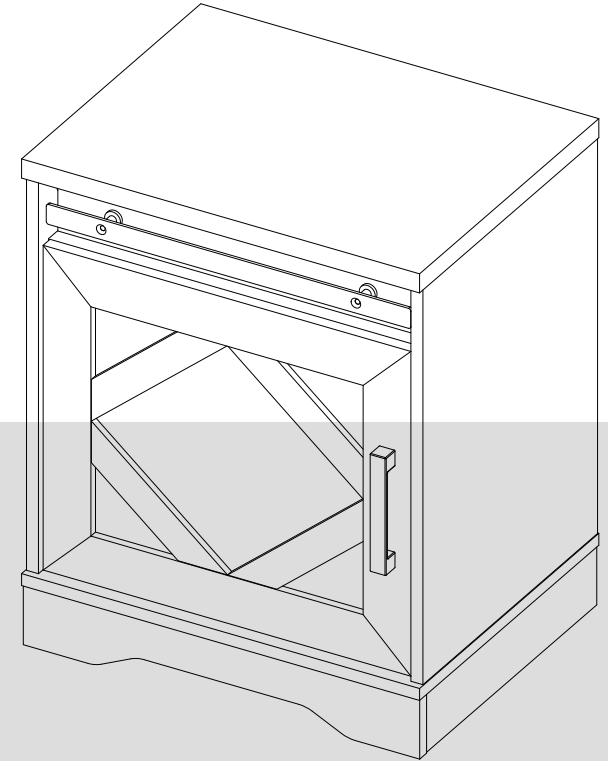

IMPORTANT : please read this manual carefully before beginning assembly of this product. keep this manual for future reference.

WHAT'S
IN THE BOX

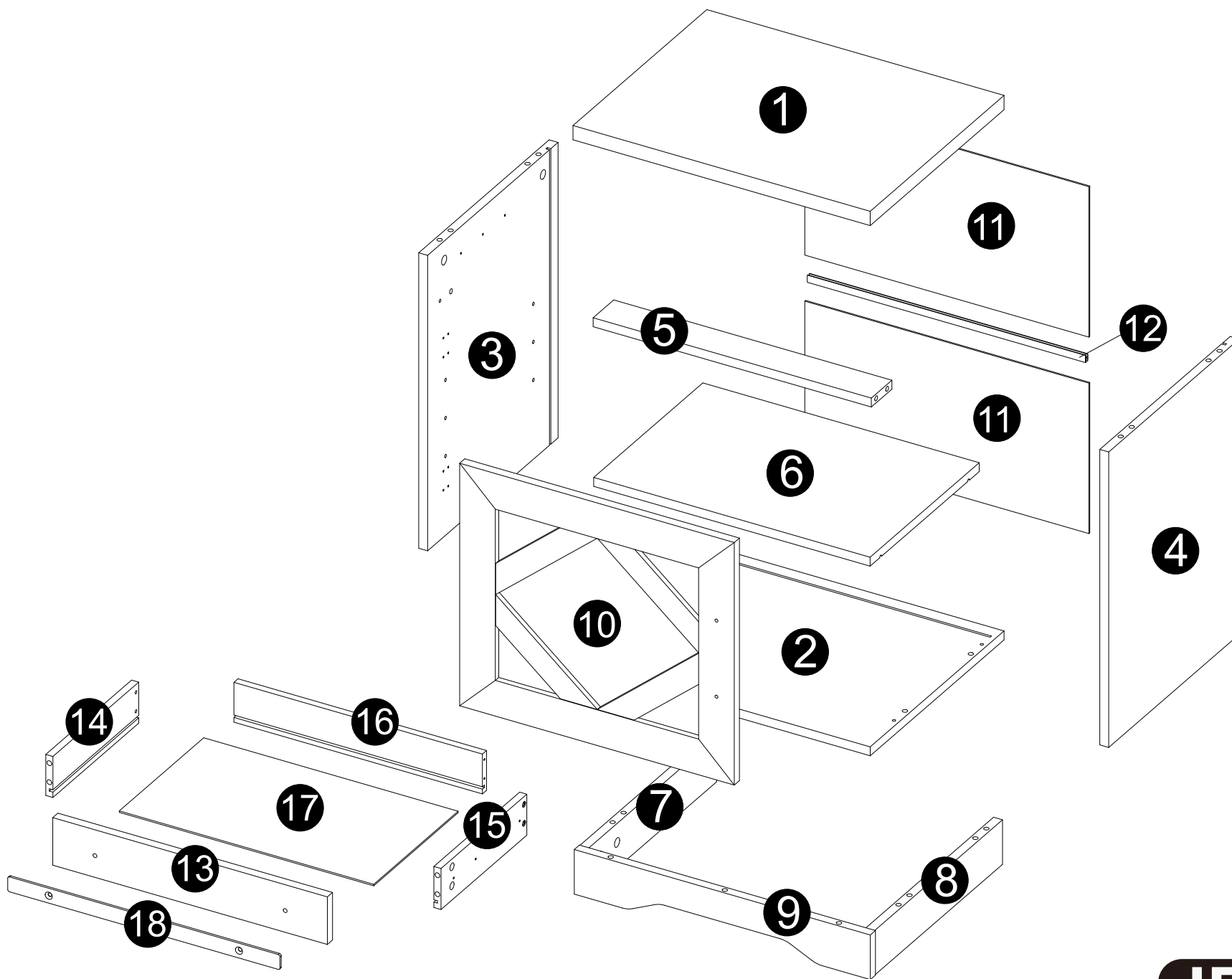

JF

WHAT'S
IN THE BOX

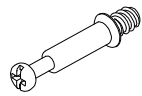

Cam bolt

A x 18



Cam lock

B x 14



Wooden dowel

C x 17



Shelf support pin

D x 4

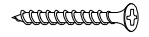

Screw

E x 8

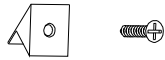

Plastic wedge
with screw

F x 8

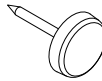

PVC nail with pin

G x 6



Screw

H x 24

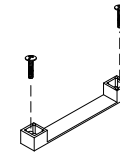

Handle with bolts

I x 1



Cam lock

J x 4



Wrench

K x 1

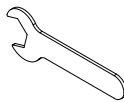

Wrench

L x 1

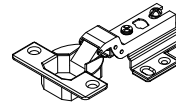

M x 2

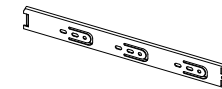

Drawer slider

N x 2

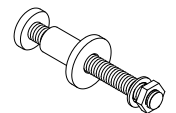

O x 2



Sticker

P x 2

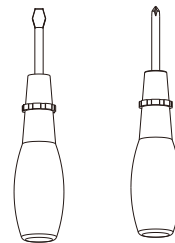

Tools Required
(Not included)

1

INSTALLATION STEPS

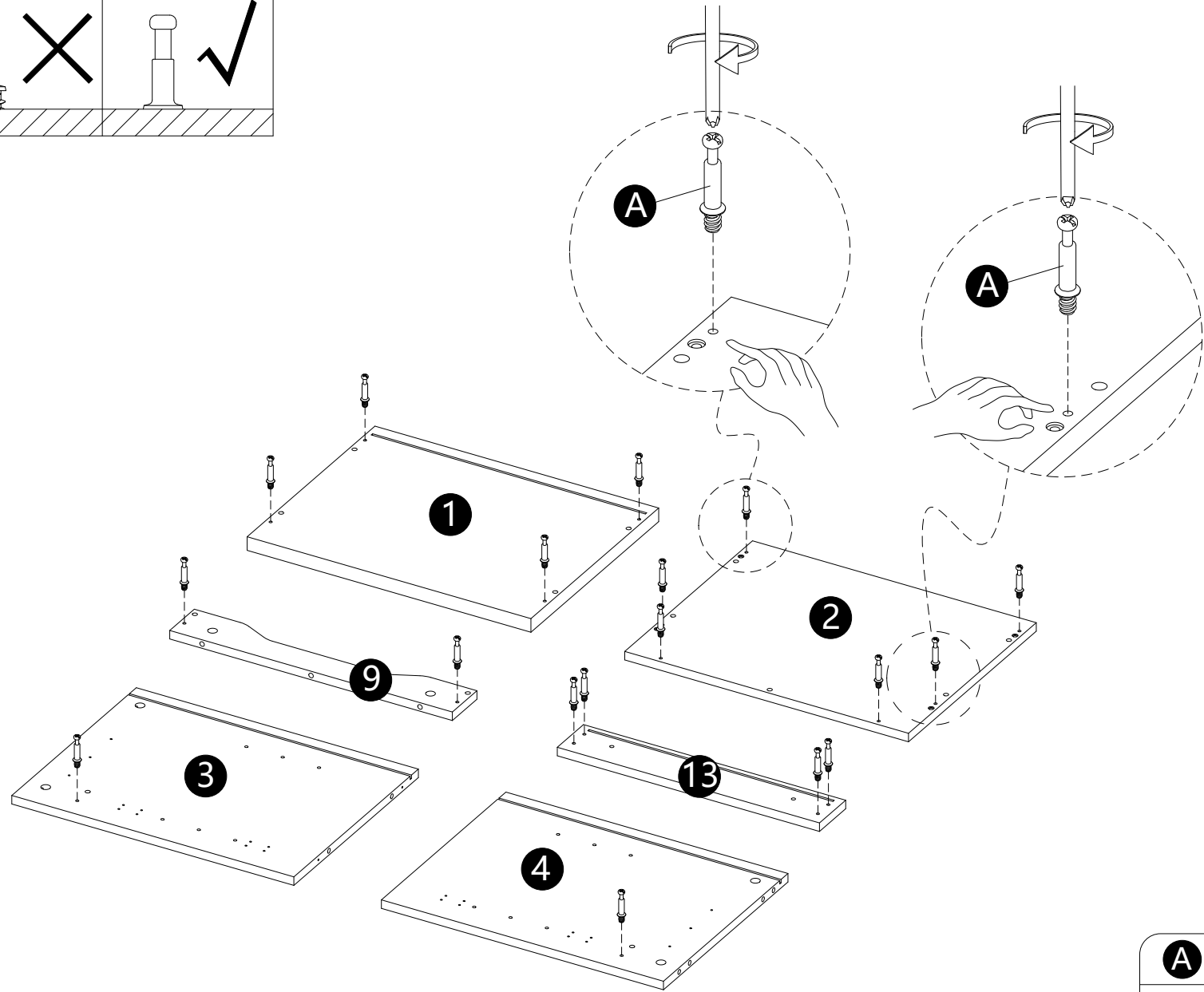
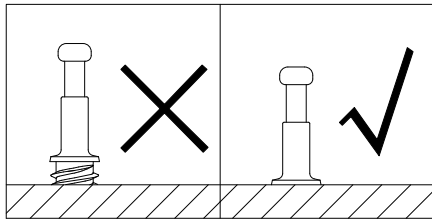

· Screw cam bolts (A) into panels (1,2,3,4,9,13).

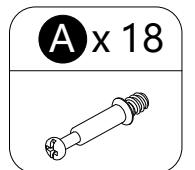

2

INSTALLATION STEPS

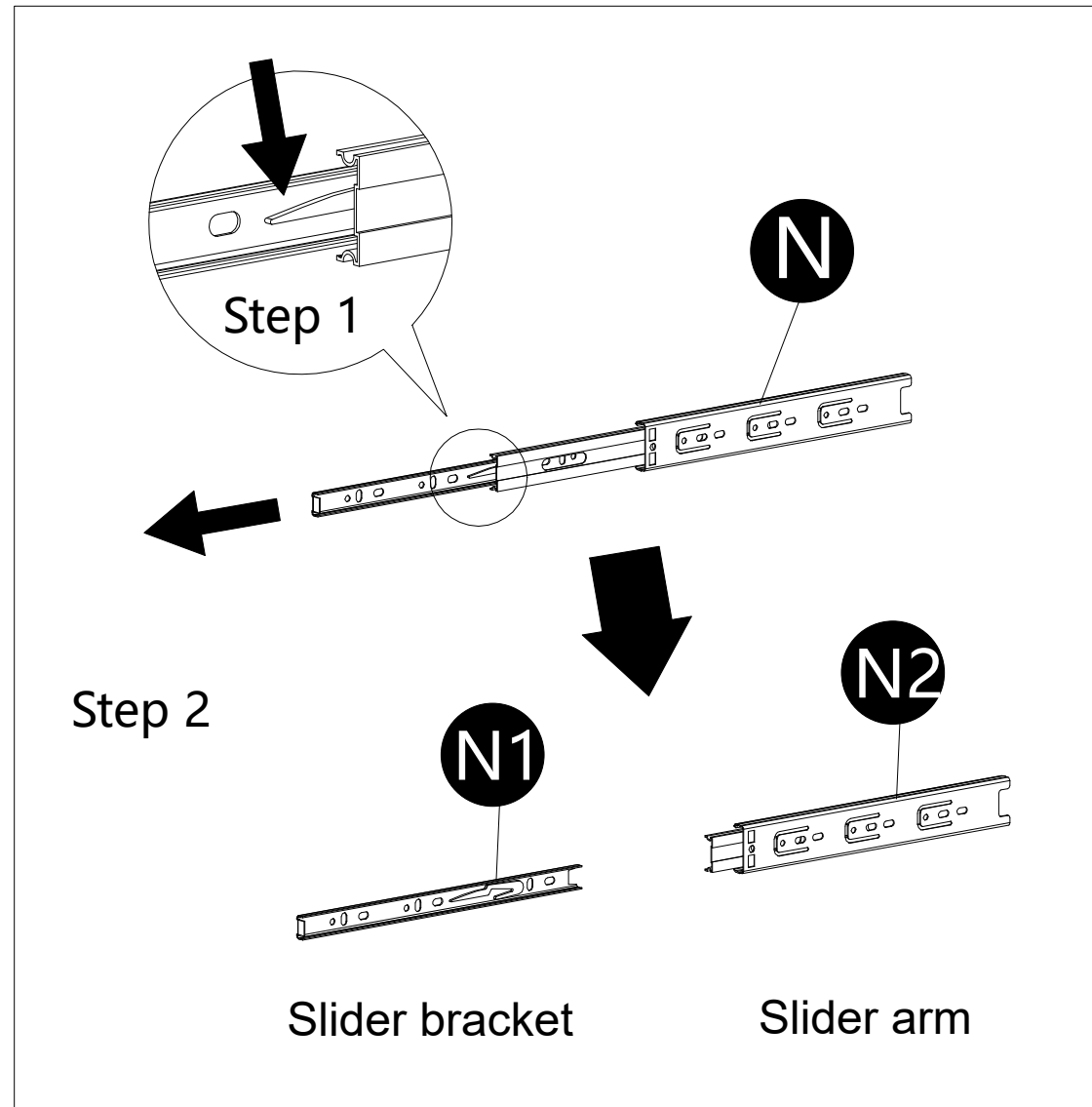

- Separate the slide bracket from the slide arm as per diagram.

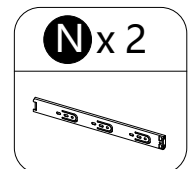

3

INSTALLATION STEPS

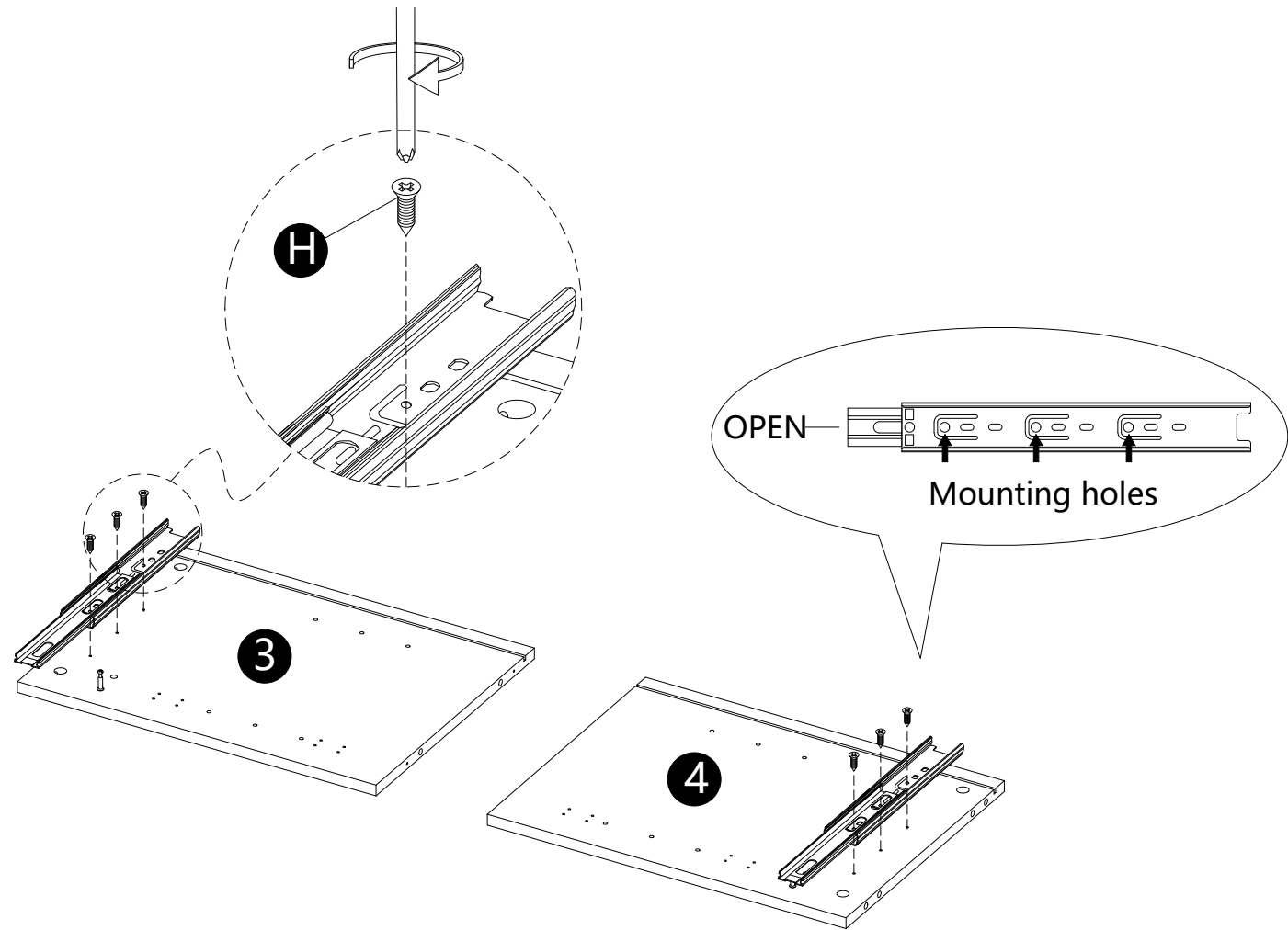

· Attach slider arms to panels (3,4) with screws (H) correctly.



4

INSTALLATION STEPS

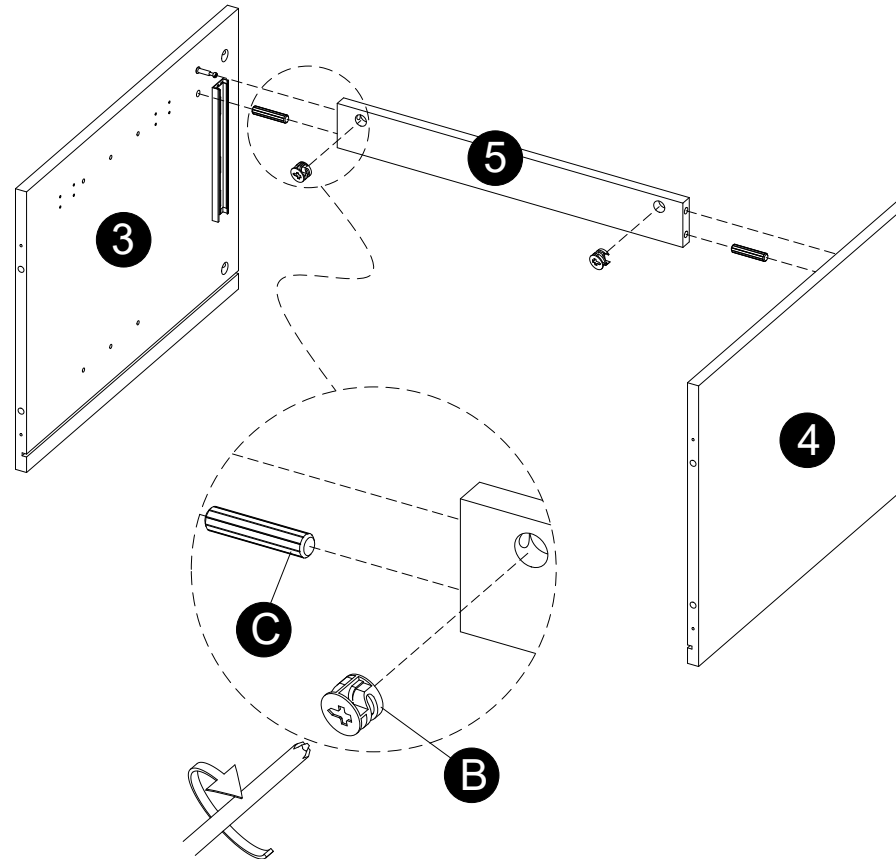
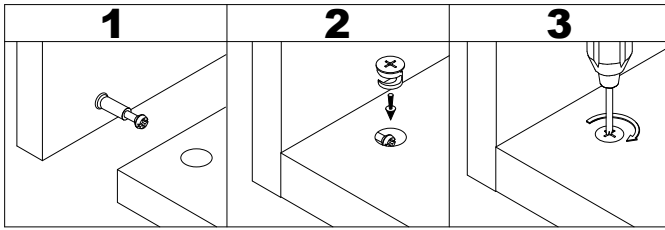

- Insert dowels (C) into panel (5).
- Attach panel (5) to panels (3,4).
- Insert and secure cam locks (B) to panels (5) to lock it.

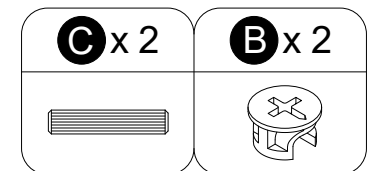

5

INSTALLATION STEPS

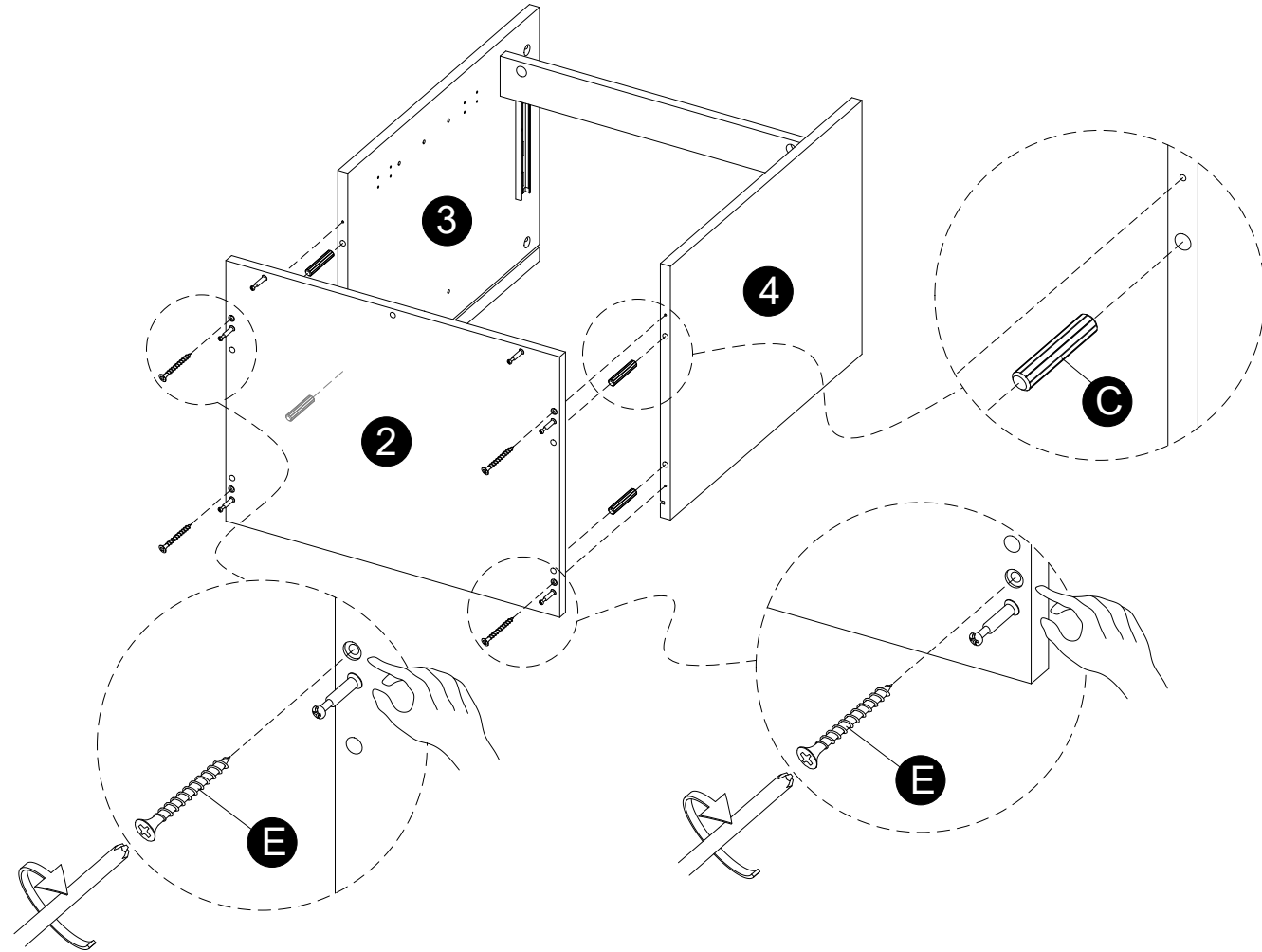

- Insert dowels (C) into panels (3,4).
- Attach panel (2) to panels (3,4) with screws (E) .

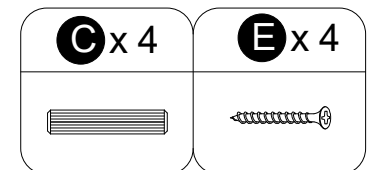

6

INSTALLATION STEPS

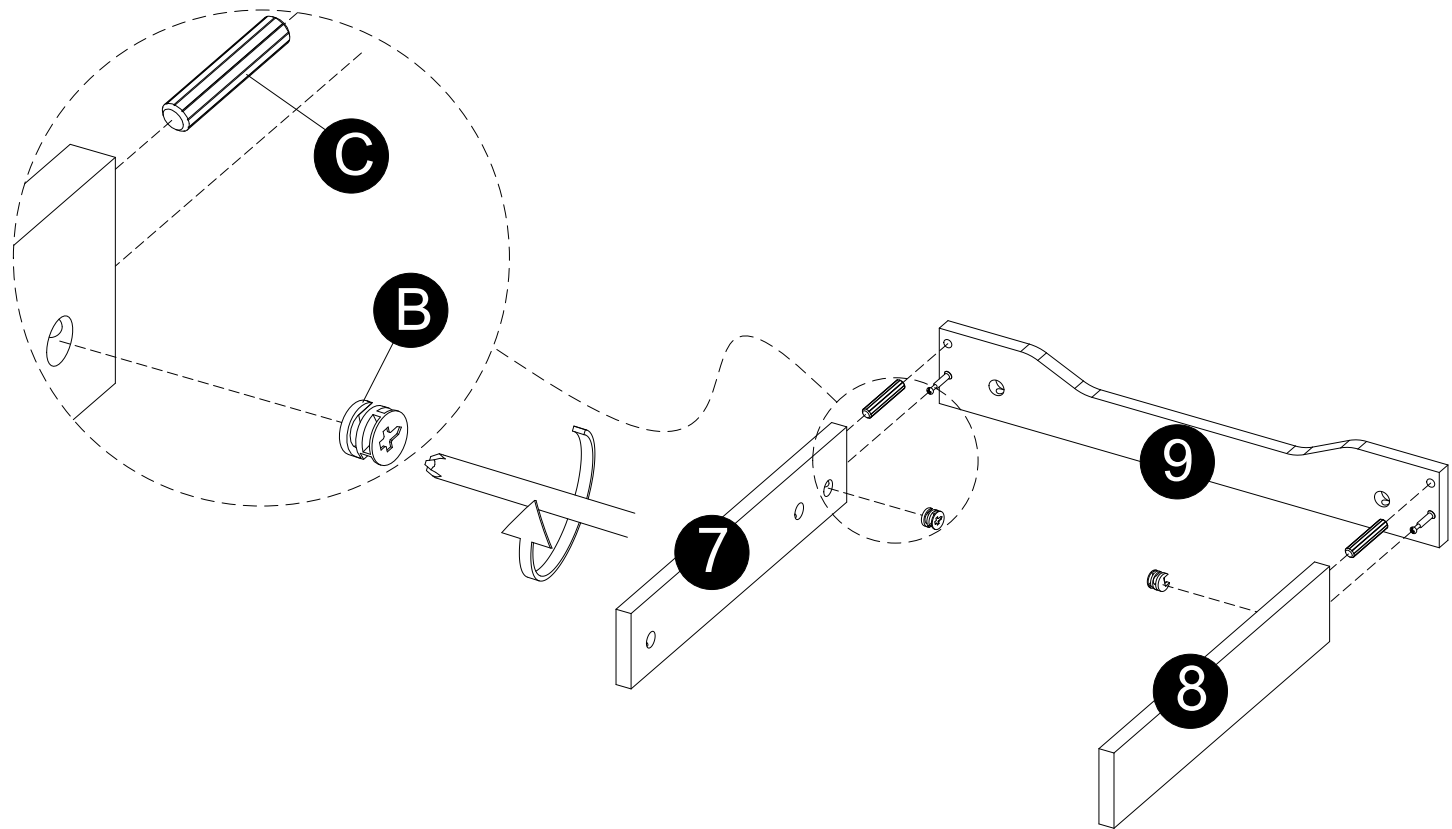
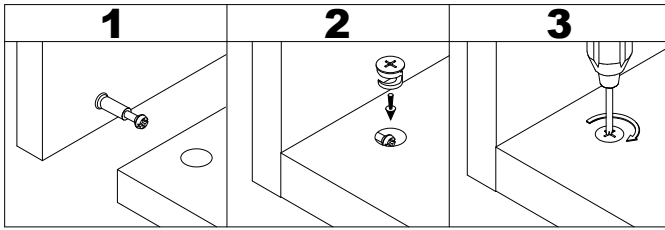

- Insert dowels (C) into panels (7,8).
- Attach panel (9) to panels (7,8).
- Insert and secure cam locks (B) to panels (7,8) to lock it.

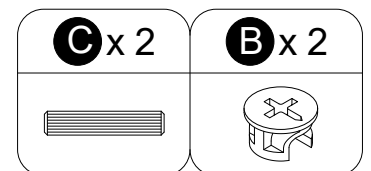

7

INSTALLATION STEPS

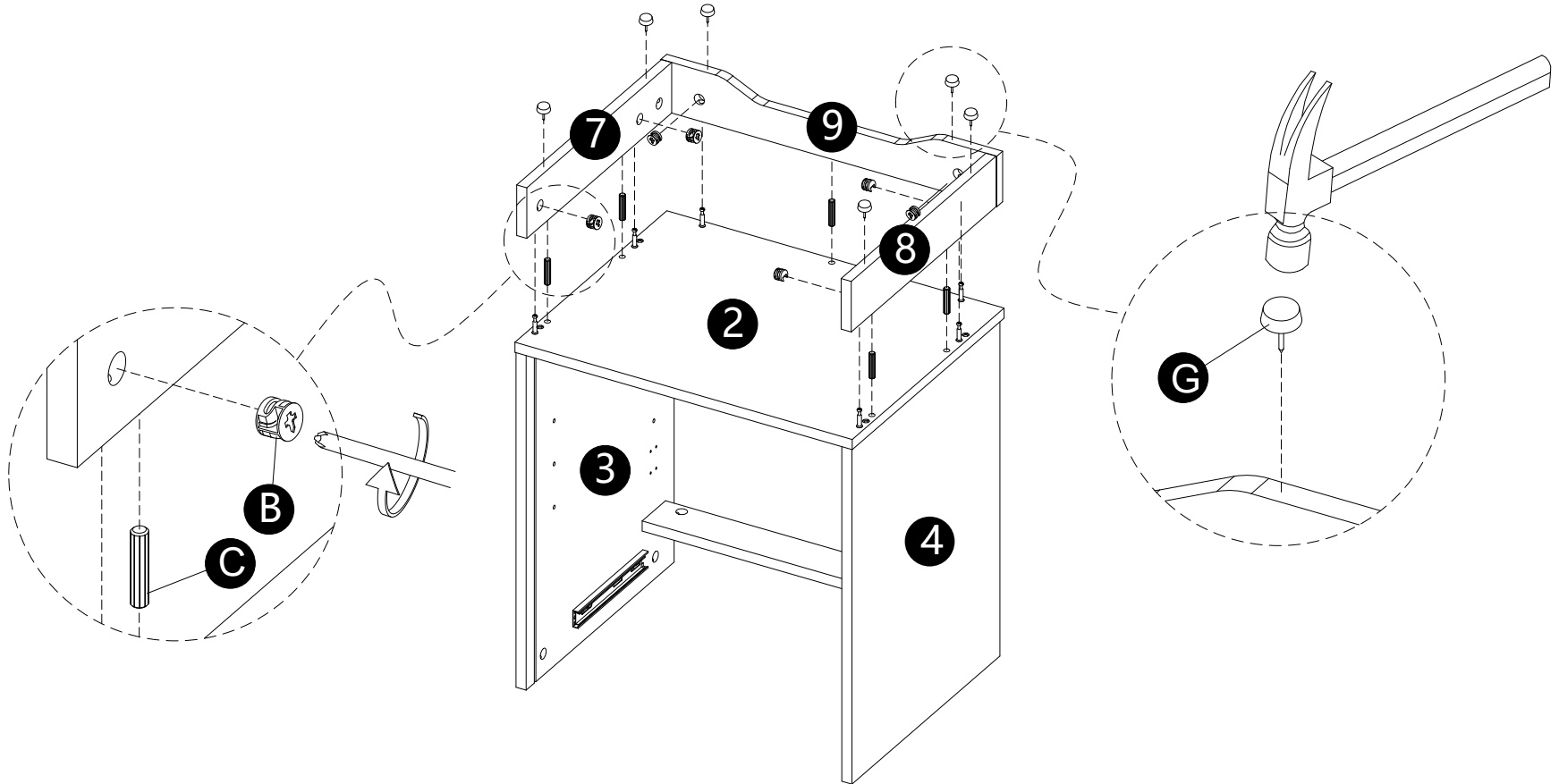
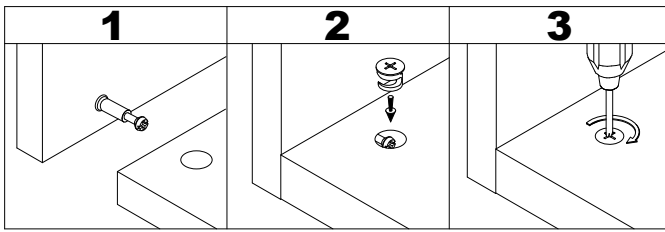

- Insert dowels (C) into panel (2).
- Attach panels (7,8,9) to part (2).
- Insert and secure cam locks (B) to panels (7,8,9) to lock it.
- Knock pins (G) into panels (7,8,9).

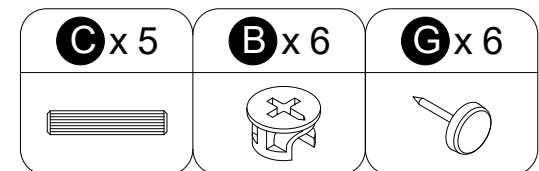

8

INSTALLATION
STEPS

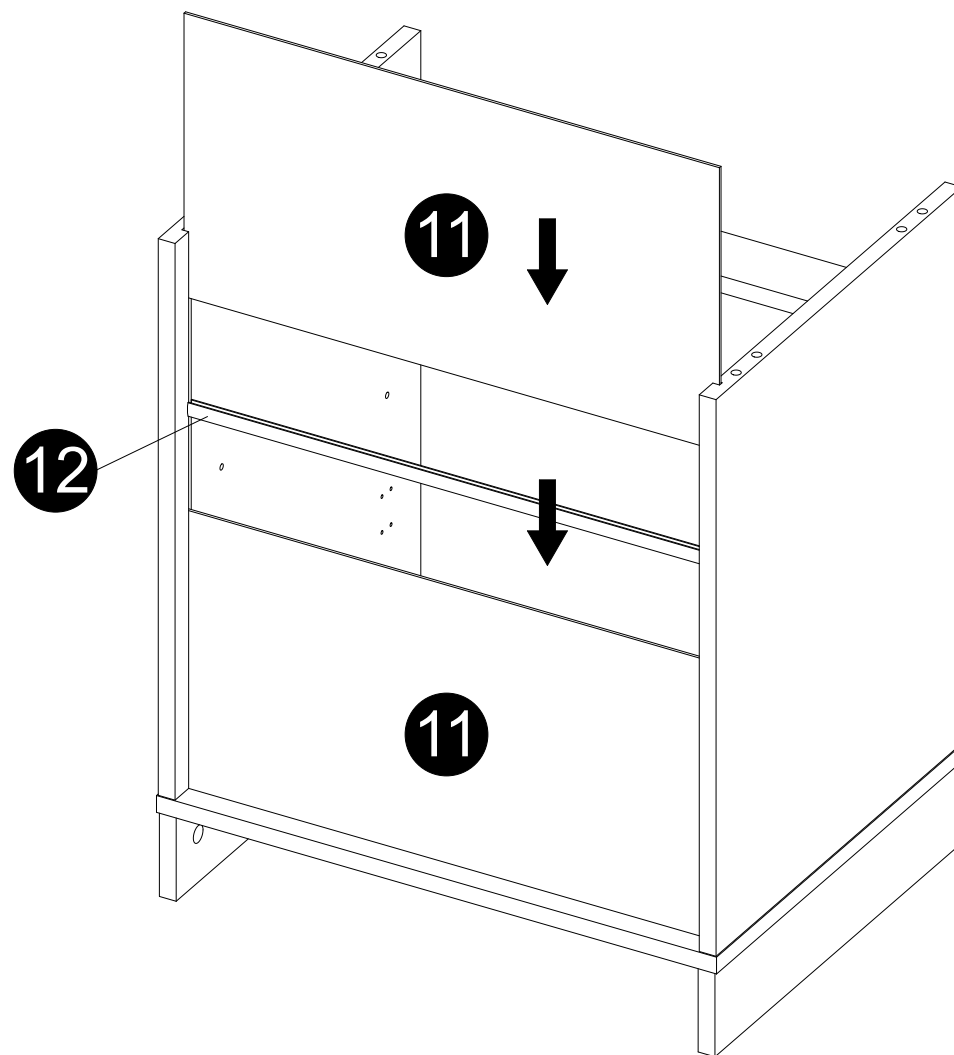

· Carefully slide part (11,12) into place along the back of the assembly.

9

INSTALLATION STEPS

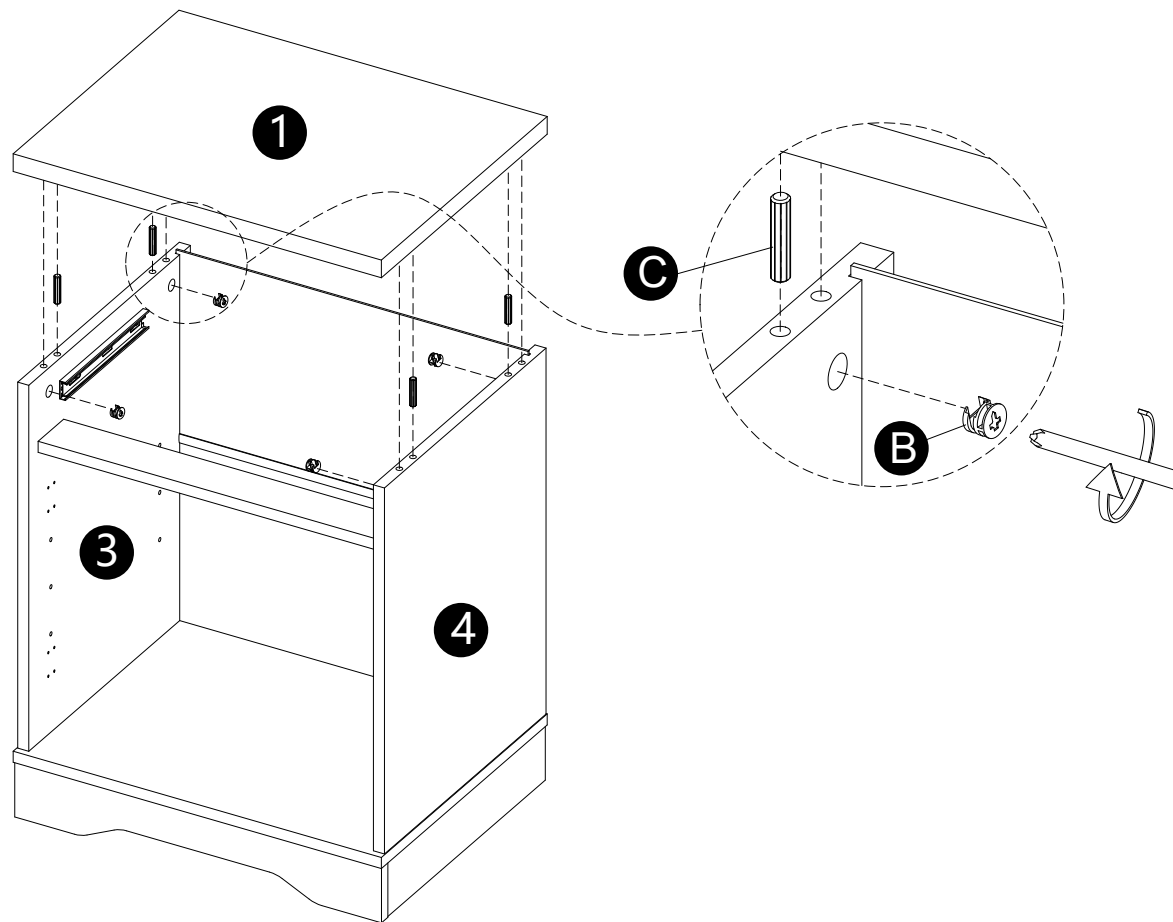
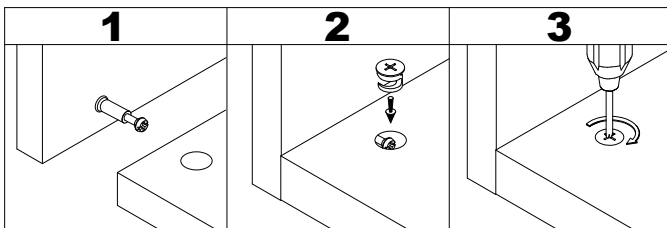

- Insert dowels (C) into panels (3,4).
- Attach panel (1) to panels (3,4).
- Insert and secure cam locks (B) to panels (3,4) to lock it.

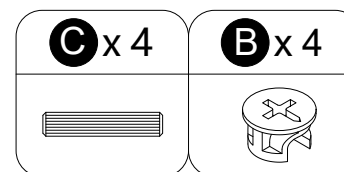

10

INSTALLATION STEPS

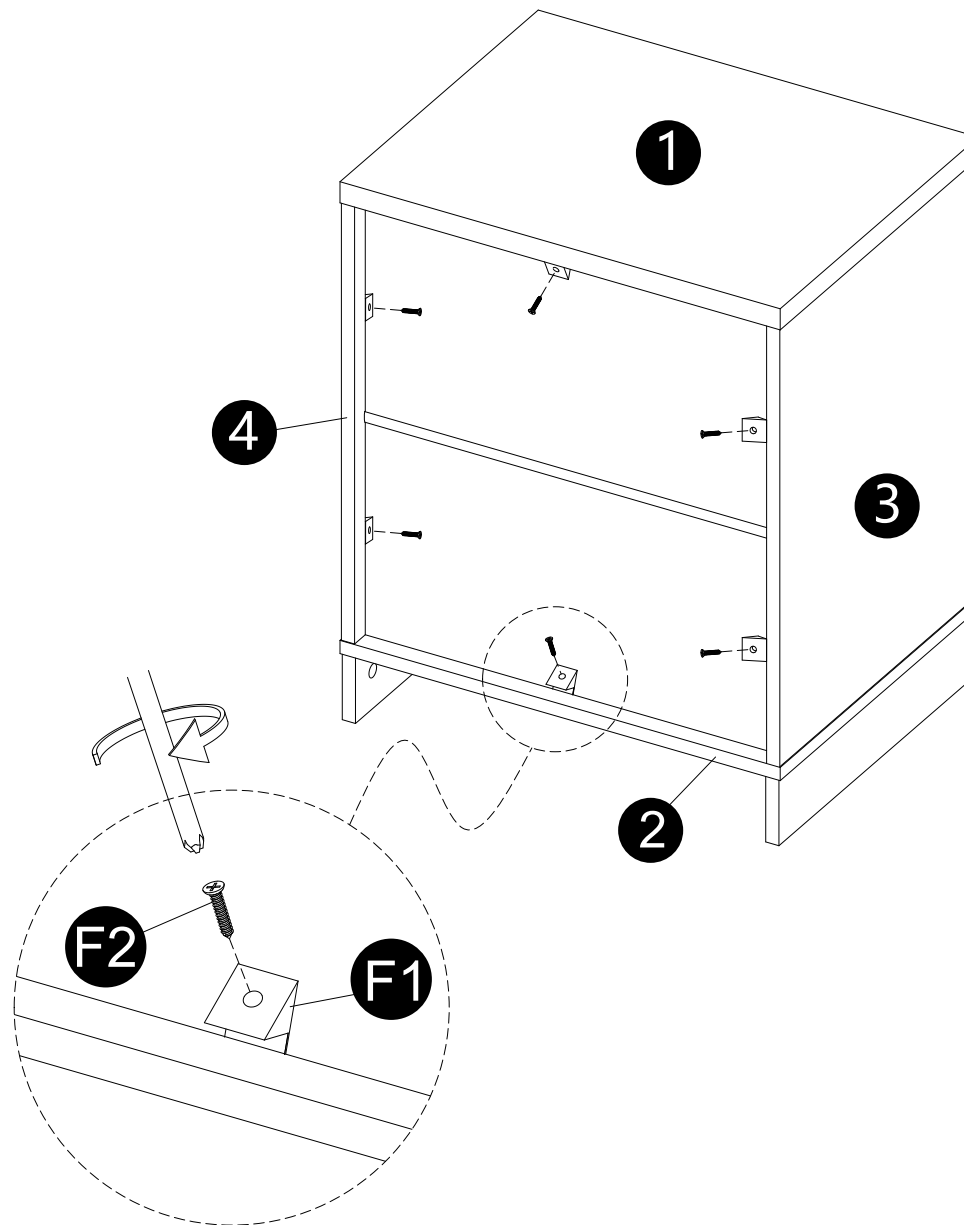

· Secure parts (F1) with screws (F2) as per diagram.

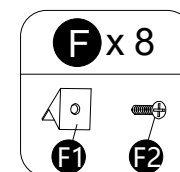

11

INSTALLATION STEPS

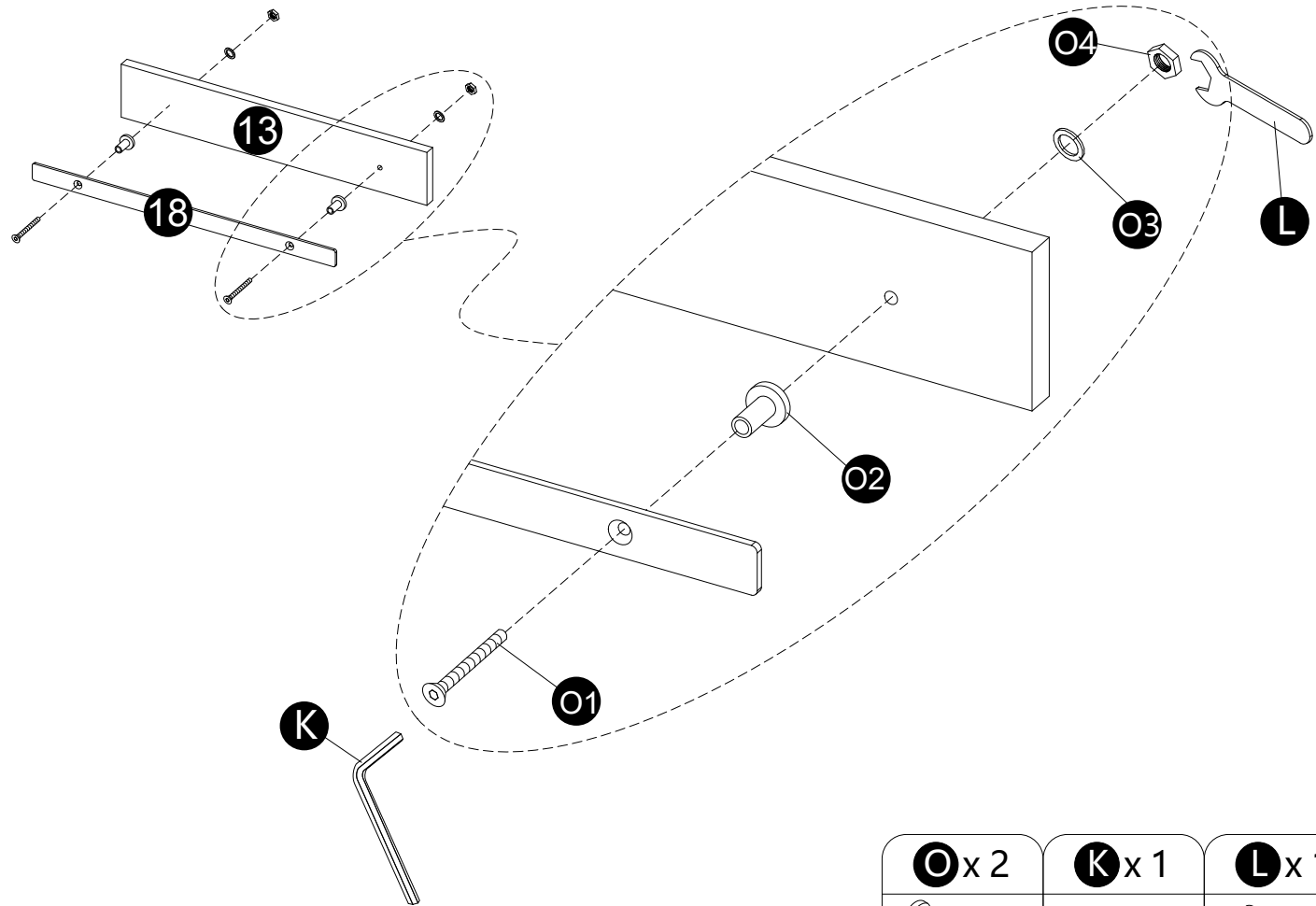
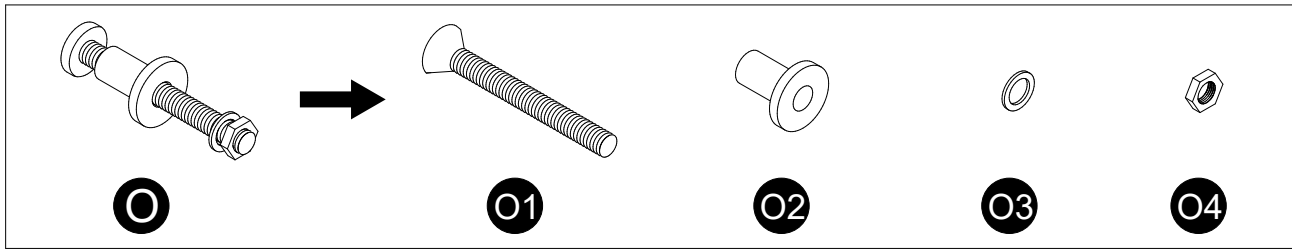

· Screw parts (O) to panel (13) with parts (K,L) .

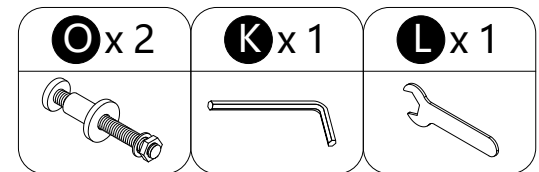

12

INSTALLATION STEPS

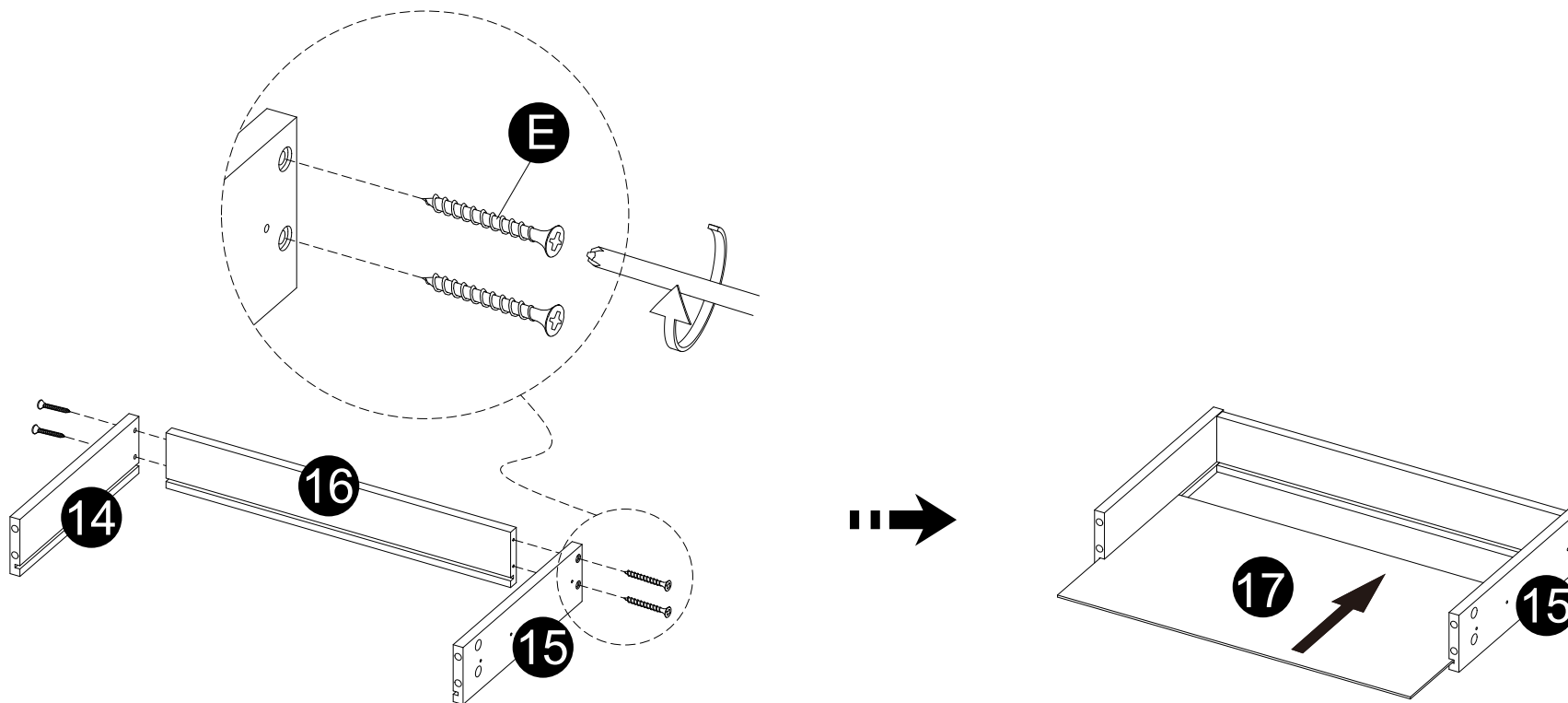

- Attach panels (14,15) to panel (16) with screws (E).
- Carefully slide panel (17) into place along the bottom of the assembly.

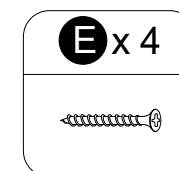

13

INSTALLATION STEPS

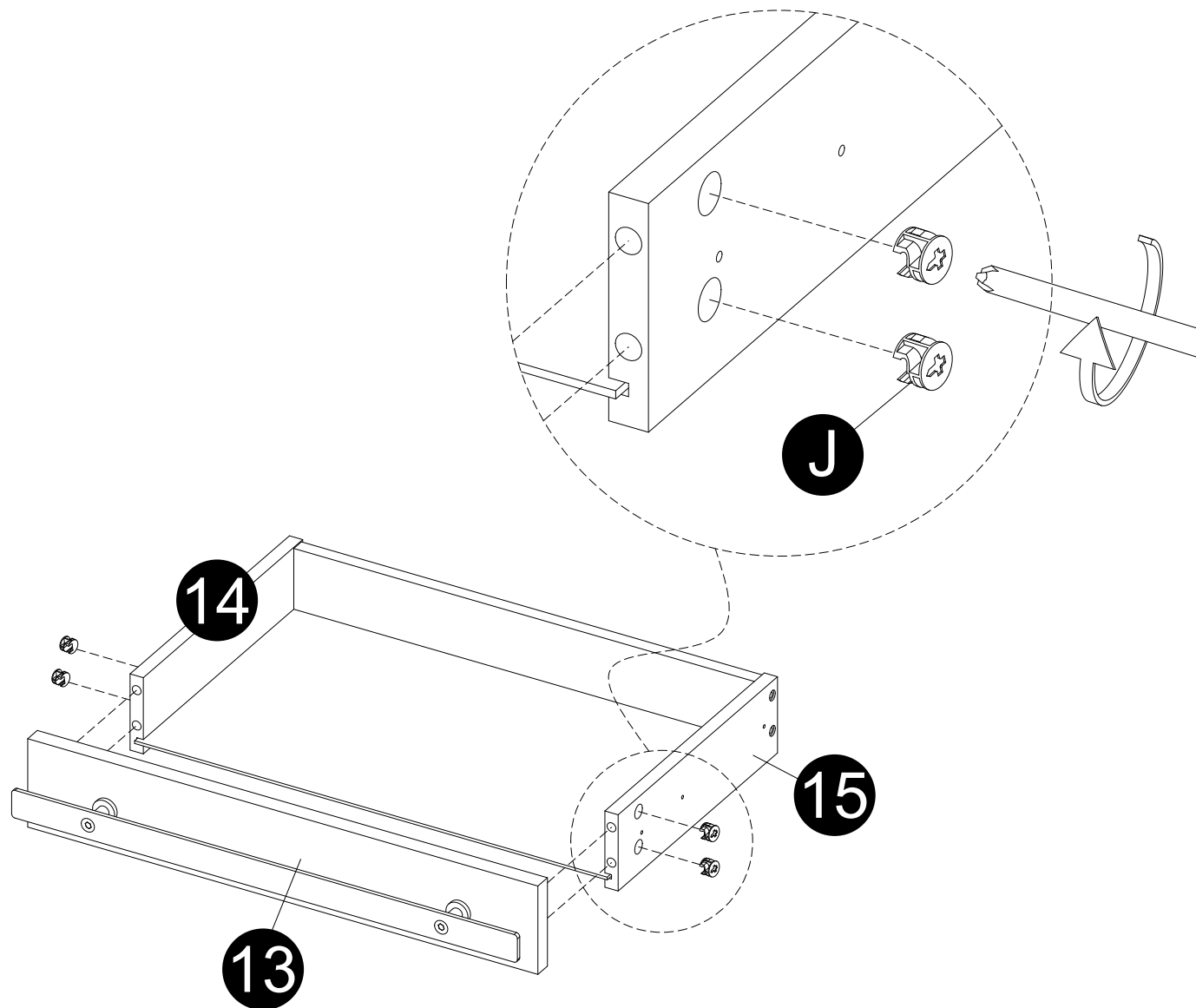

- Attach part (13) to panels (14,15).
- Insert and secure cam locks (J) to panels (14,15) to lock it.

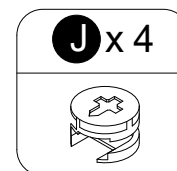

14

INSTALLATION STEPS

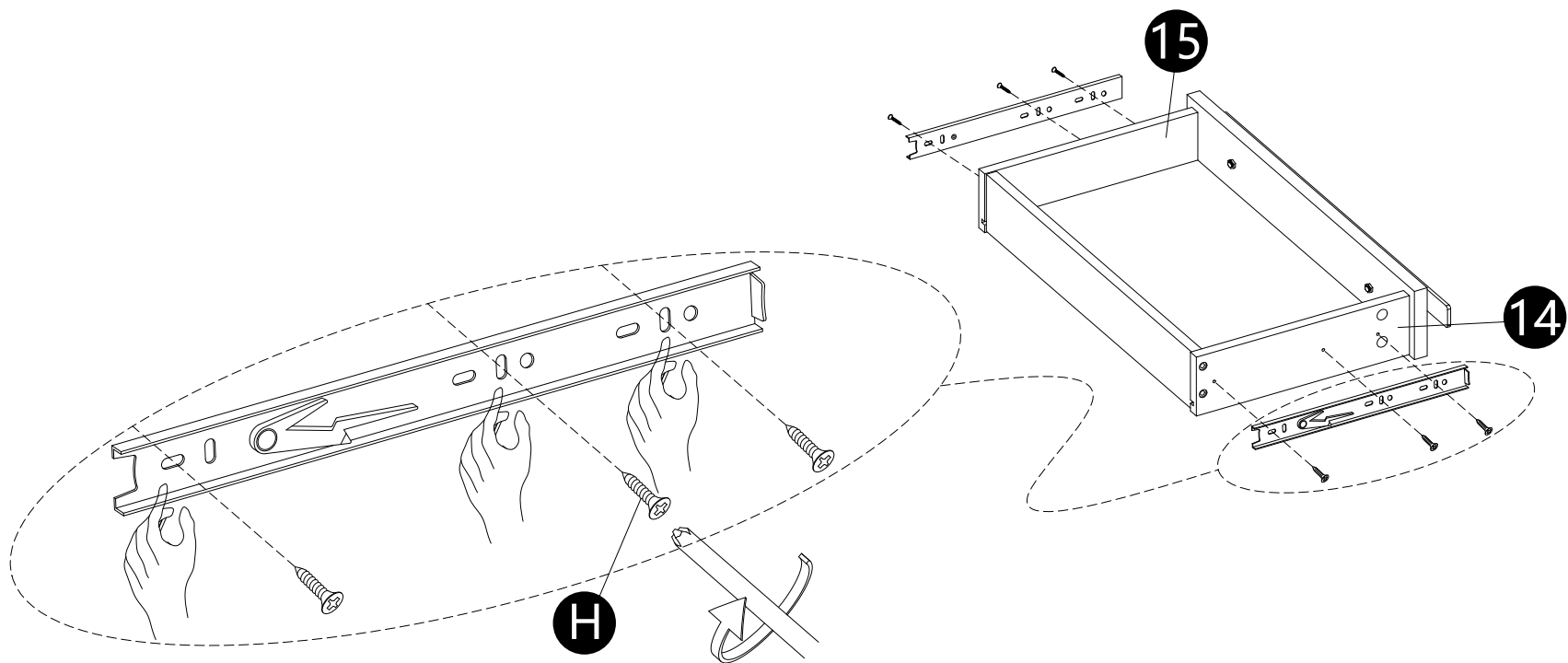

· Attach slider brackets to panels (14,15) with screws (H) correctly.

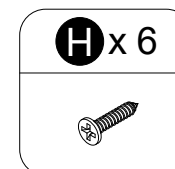

15

INSTALLATION STEPS

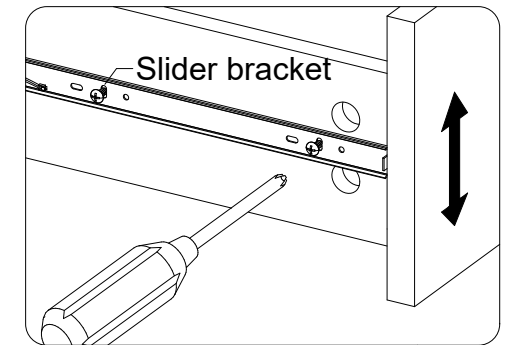
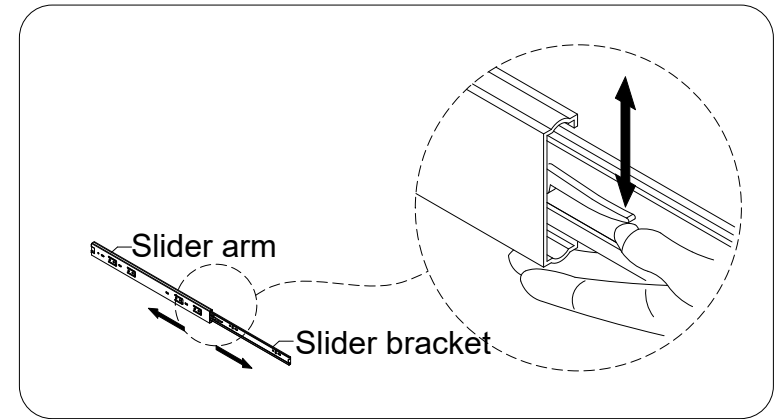
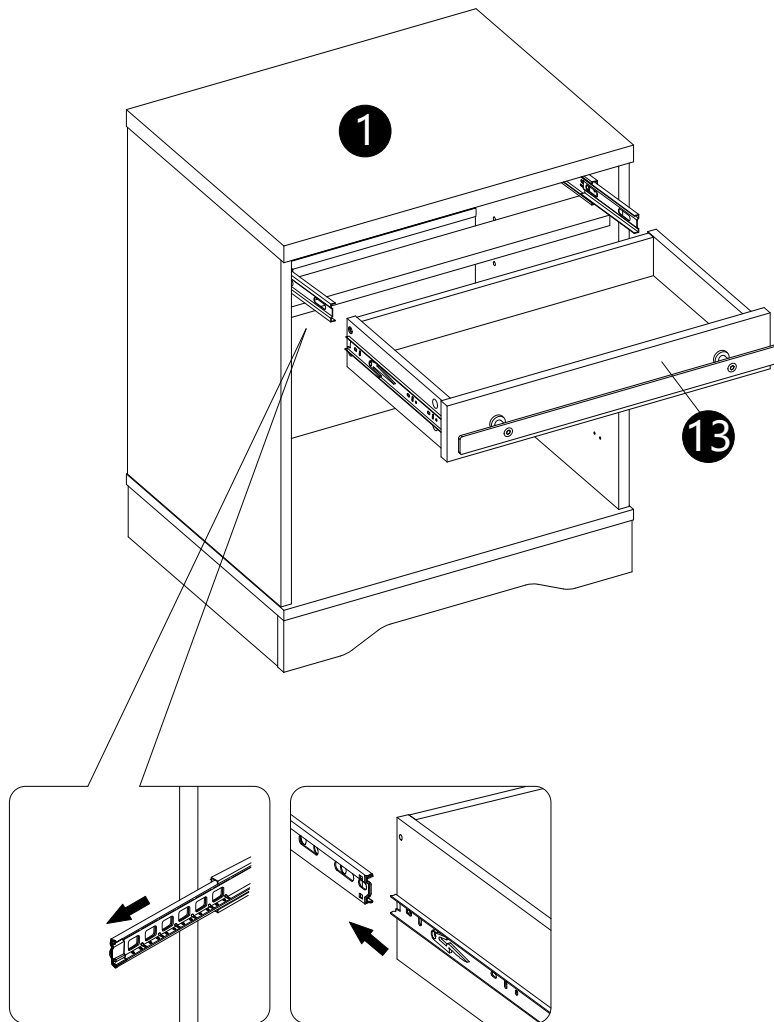

· Assembled the drawers as per diagram

Note :

If the drawer does not go in smoothly.
Press or lift the plastic release lever.
Pull out the slider bracket from
the slider arm.

Loosen the screws (H) on slider brackets,
You can adjust up or down by a few mm.
Then tighten back up.

Finally re-assembled the drawer until
they were going in smoothly well.

16

INSTALLATION STEPS

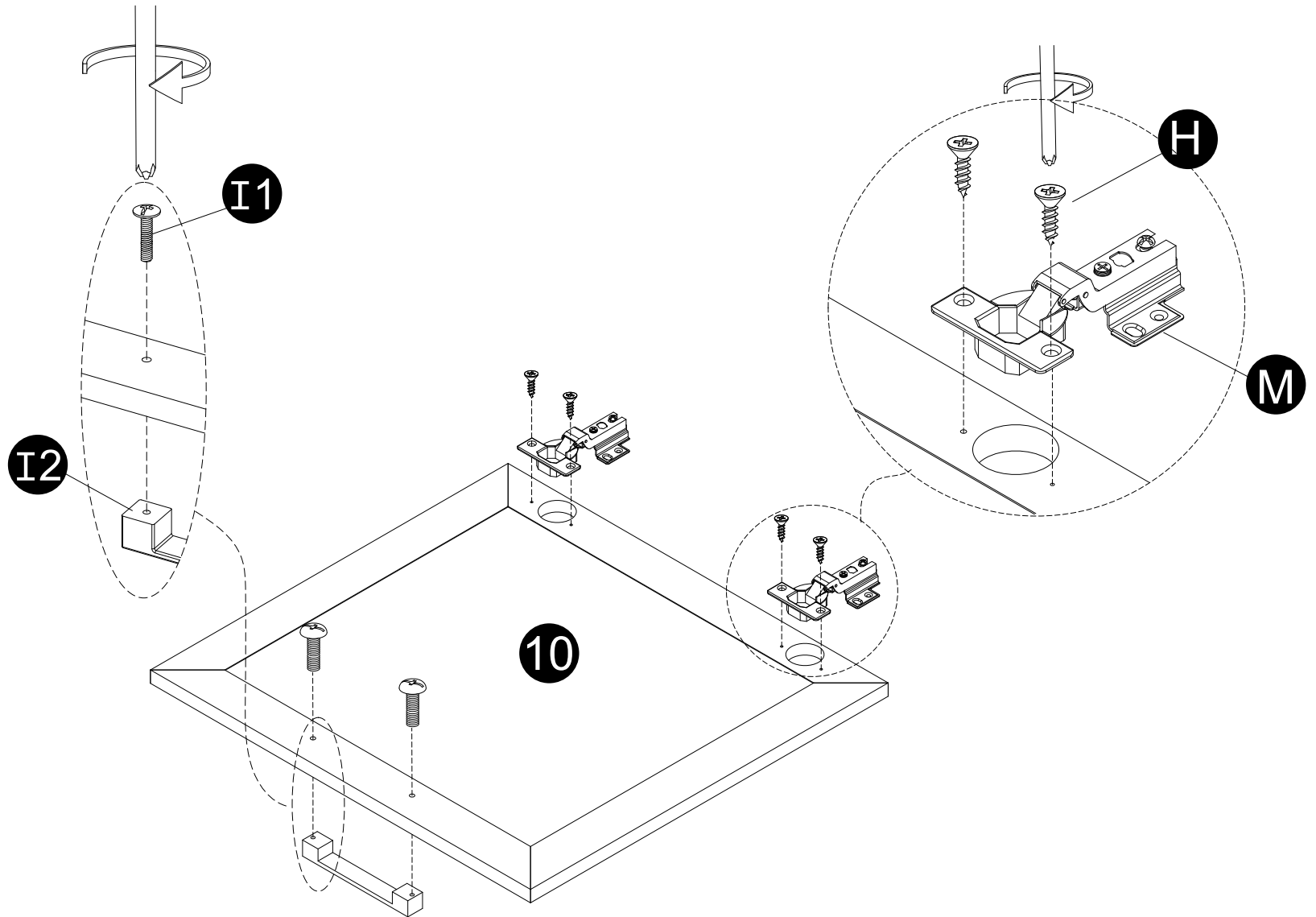

- Attach part (M) to panel (10) with screws (H) correctly.
- Attach part (I2) to panel (10) with bolts (I1) correctly.

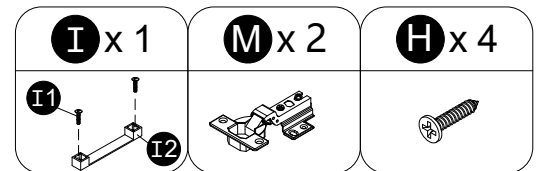

17

INSTALLATION STEPS

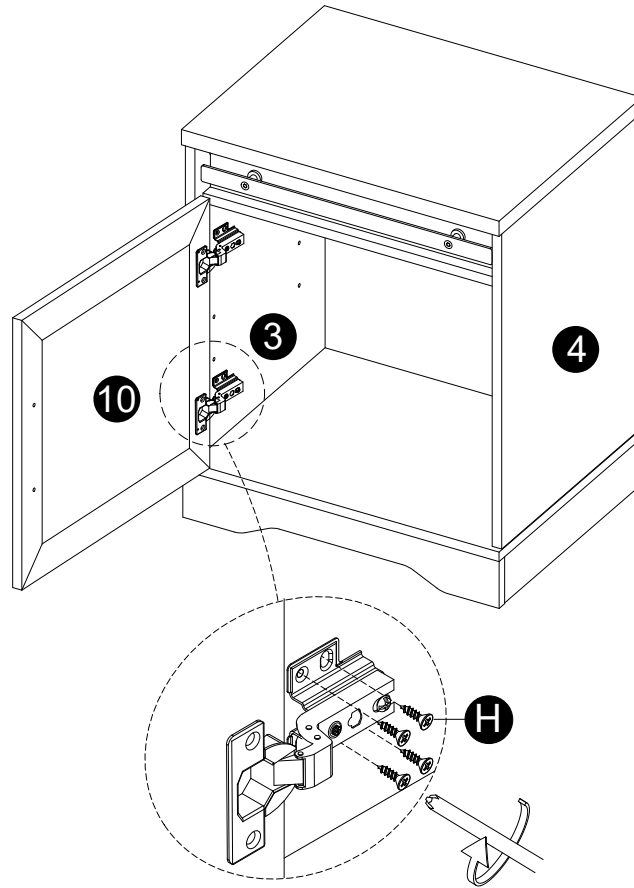

OR

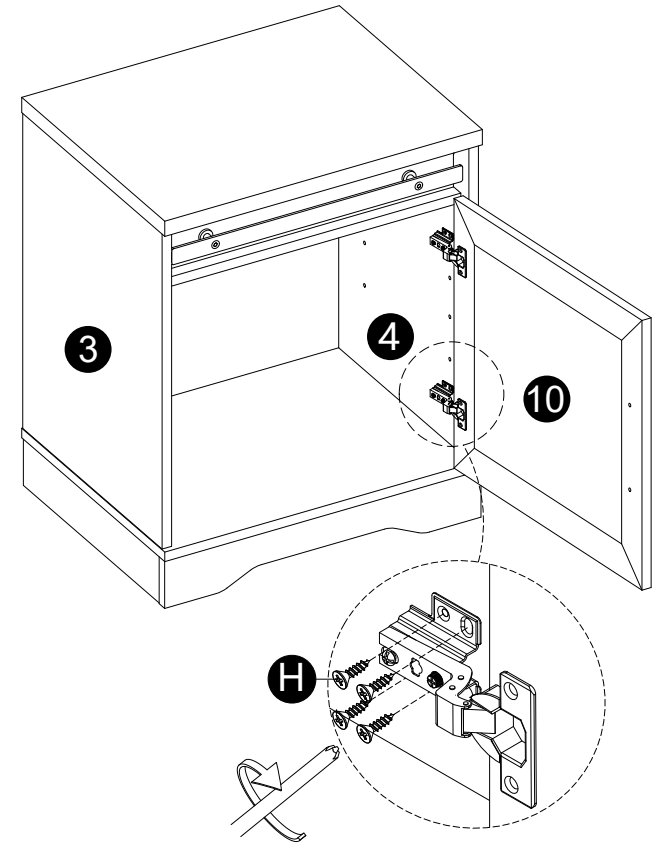

· Attach part (10) to panel (3) or panel (4) with screws (H) correctly.

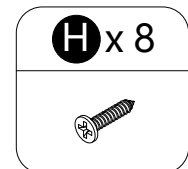

18

INSTALLATION STEPS

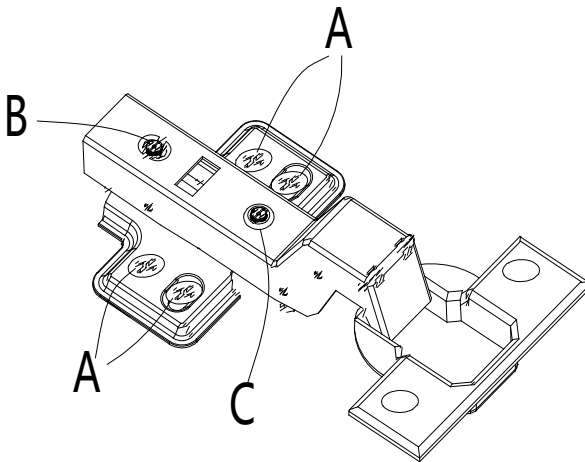

The exploded view shows a hinge with three screws labeled A, B, and C. Screw A is located in the top part of the hinge, screw B is in the middle, and screw C is in the bottom part. The hinge is shown being attached to a cabinet door.

To adjust the vertical height.
Loosen the four screws "A" on both hinges. Two of them are usually in slotted holes which mean and you can adjust up or down by a few mm. Then tighten back up.

To adjust depth.
Loosen screw "B" and adjust door, if the door can not be adjusted, please loosen screw "C", then try again. Tighten screw "B" and "C".

To adjust side ways.
Turning the screw "C" on BOTH hinges on each door.

19

INSTALLATION STEPS

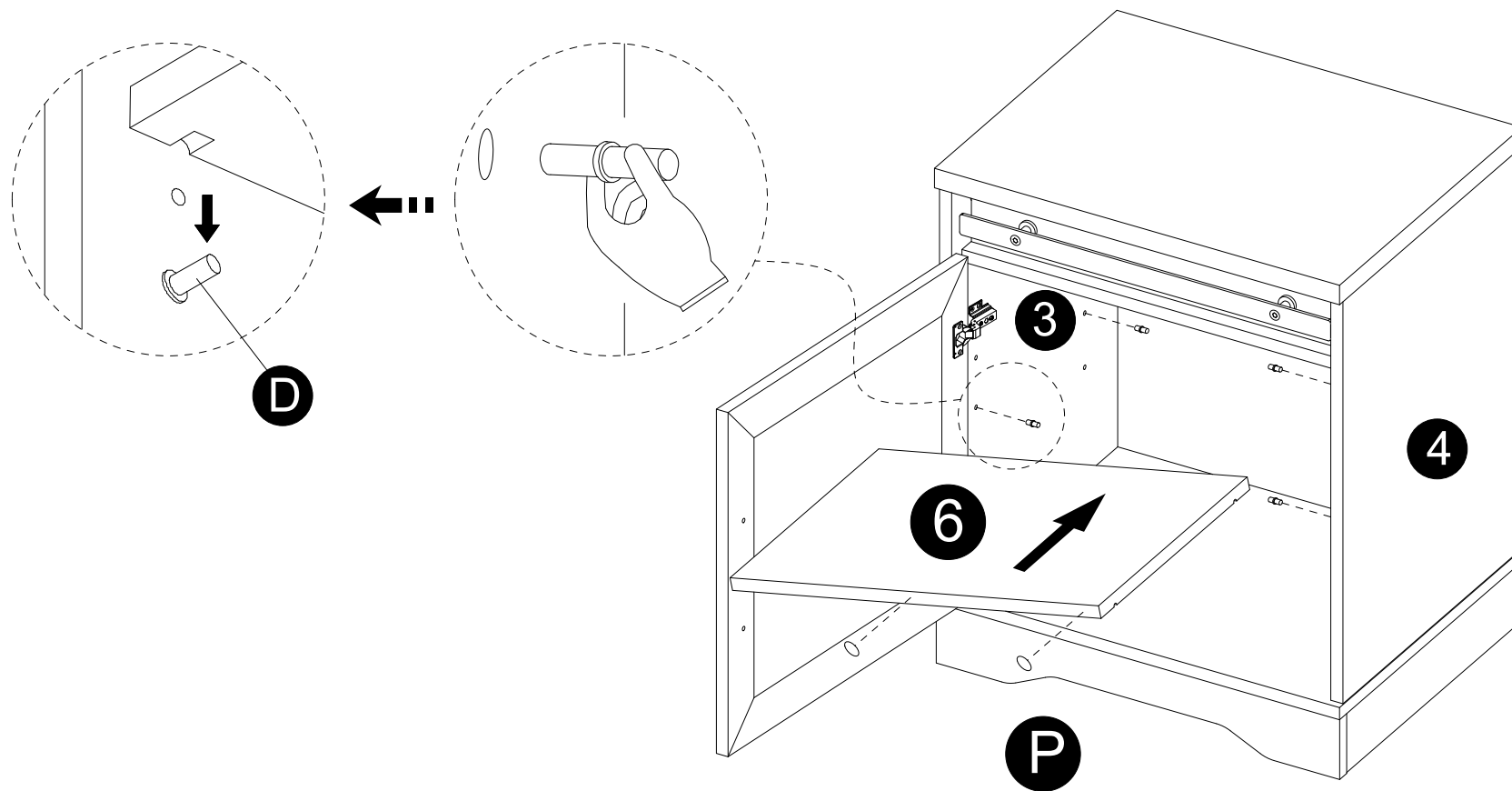

- Attach panel (5) to panels (3,4) with parts (D).
- Stick stickers (P) on the panel (6).

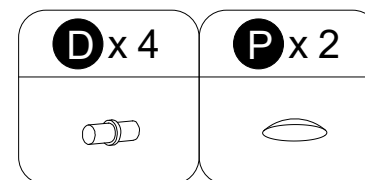

20

INSTALLATION
STEPS

Final Assembly

