

EROMMY!

JFHL010MS

Closer to Life!

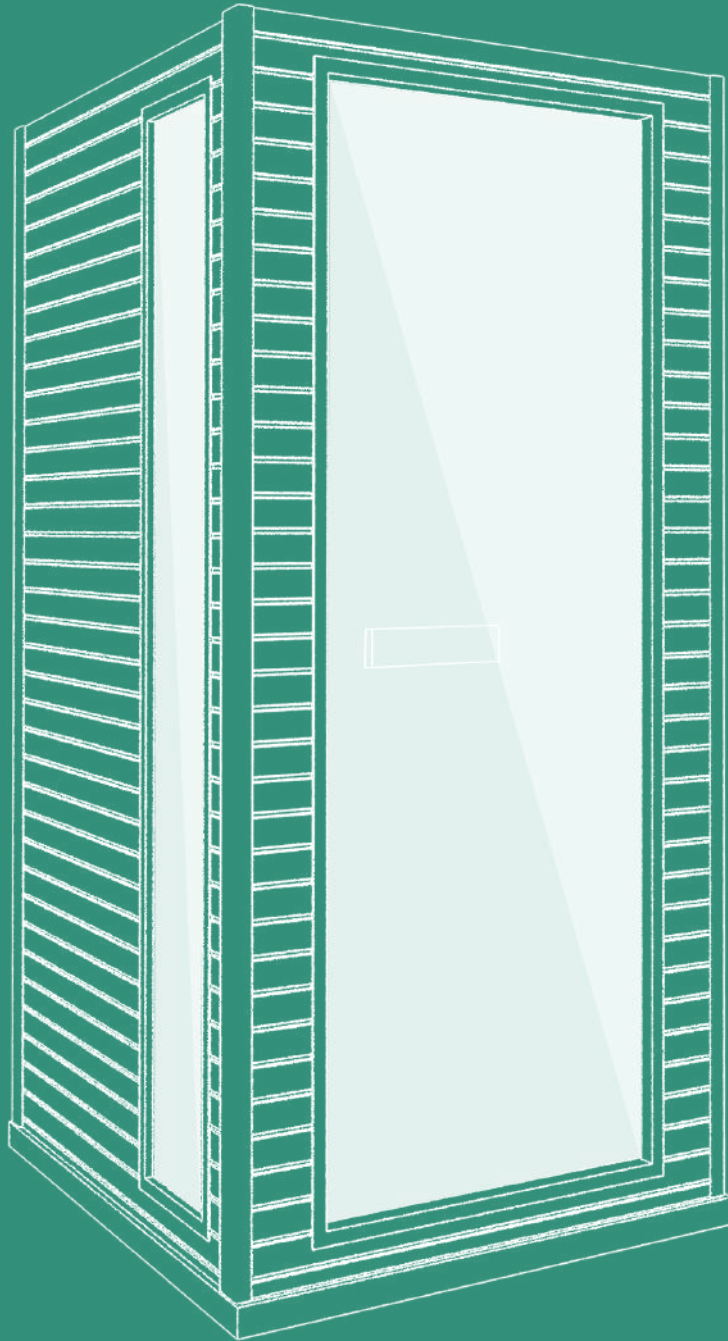

EROMMY Far Infrared Sauna

Installation Instructions (Includes Installation Video)

EROMMY PRODUCT INSTRUCTION

i Remember that the assembly might take (1) hours and requires (2) people.

REMEMBER

EROMMY isn't responsible for replacing parts lost or damaged during assembly. If you have issues, Email: service@erommy.com or Tel: **8886766299** instead of returning the unit.

WARNING

Please inspect all heaters to ensure there is no damage before assembly. Any excessive vibration during transport may cause the heater to damage the element. Do not start the sauna if damage is detected! Please contact your dealer or manufacturer for troubleshooting and parts replacement.

DISCLAIMER

The infrared rays emitted by your sauna are reported to provide a wide range of possible the rapeutic benefits, according to studies completed around the world over the past 25 years. These benefit sare only for reference and do not imply that infrared sauna will cure or treat any disease. Please consult your physician before beginning infrared therapy if you have a health problem, are taking prescription medication, or have an acute joint injury. People with surgical implants (metal pins and rods, artificial joints, silicone, or other types of surgical implants) usually do not experience any adverse effects, but they should also consult their doctor or surgeon before starting infrared therapy. Please mention models are subject to change without notice. Pictures show are for display purposes only and may differ from your exact model.

BRAND STORY

With the ideology of “closer to life” in our mind, EROMMY is committed to bring you the most refined and trustworthy products that fits your need. Our vision is to empower every customer to stay close to nature and ultimately transform their lifestyles.

EROMMY, Closer to Life!



ASSEMBLY VIDEO



ACCESSORIES LIST

BOX A

P1

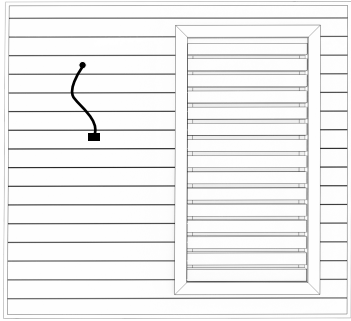

Floor Panel x 1

P8

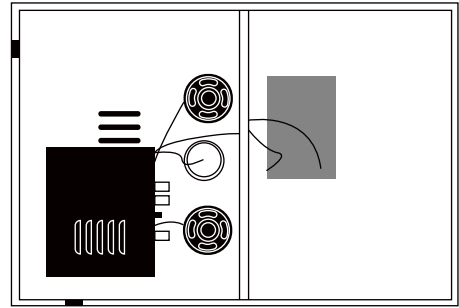

Ceiling x 1

P5

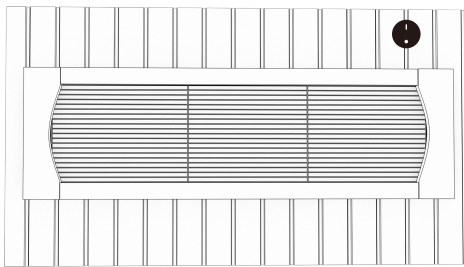

Bench Support x 1

P6

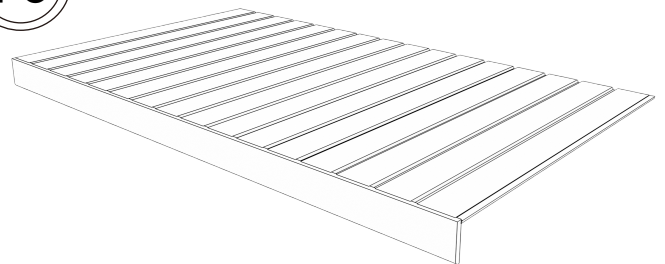

Seat Panel x 1

P9

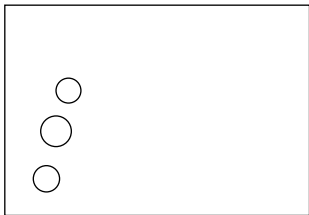

Dust-proof Cover x 1

P10

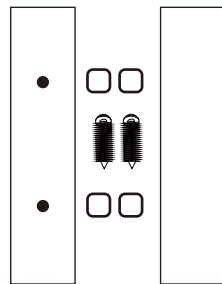

Door Handle x 1

P11

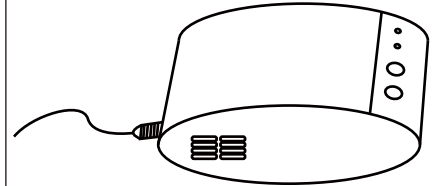

Oxygen Ionizer x 1

P12

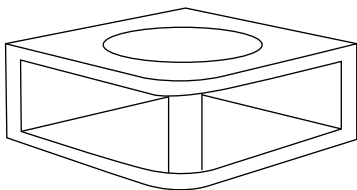

Cup Holder x 1

P13

Screws

1.6cm x 10pcs  assemble the dust-proof cover

2.5cm x 2pcs  install the cup holder

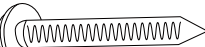
3.5cm x 12pcs,  fix the ceiling with rear, side, front panels

P14

When use the LED beauty lamp, please put on the glasses or no staring at the lamp to prevent your eyes from hurt.

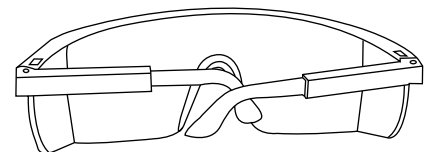

Glasses for LED Beauty Lamp x 1

ACCESSORIES LIST

BOX B

P2

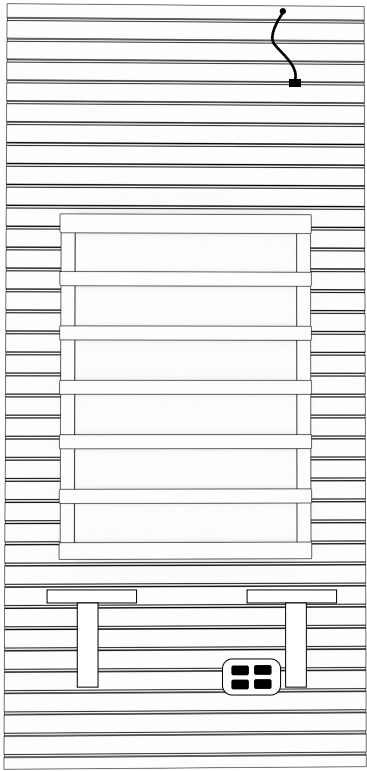

Rear Panel x 1

P3

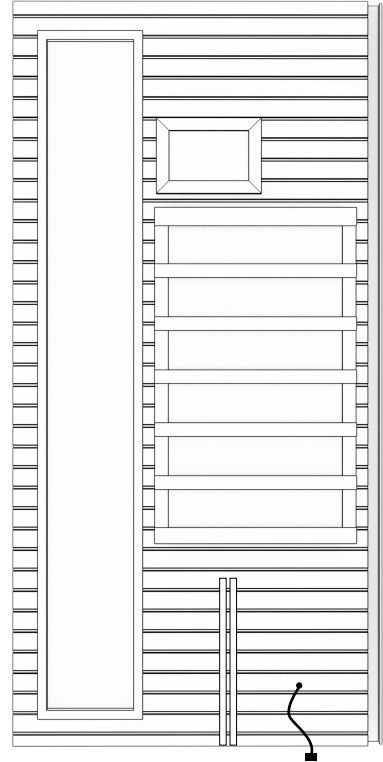

Left Panel x 1

P4

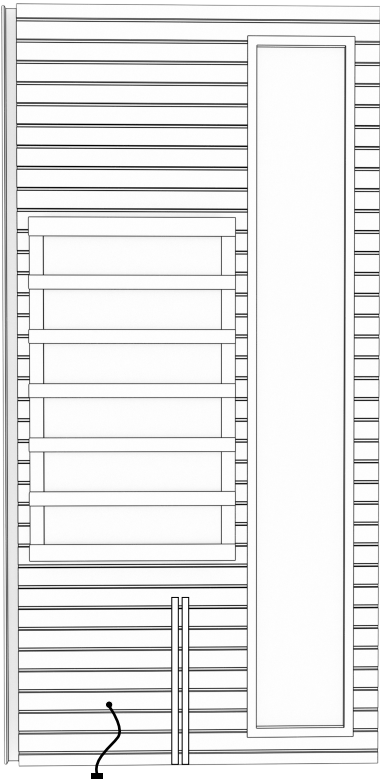

Right Panel x 1

P7

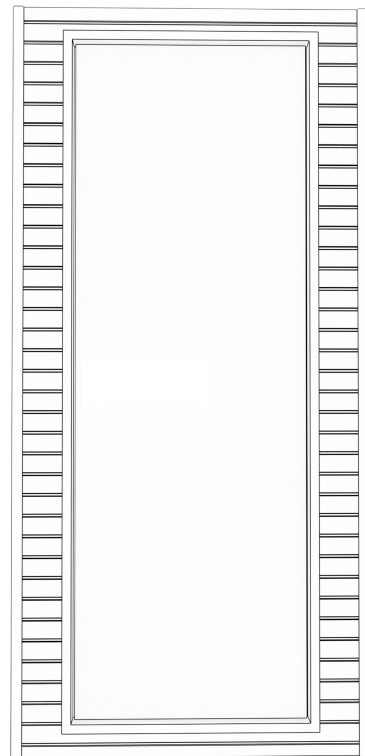

Front Panel x 1

ASSEMBLY STEP

1

1. Place part P2 and P3 on the Part P1 in order.

Fasten by buckles

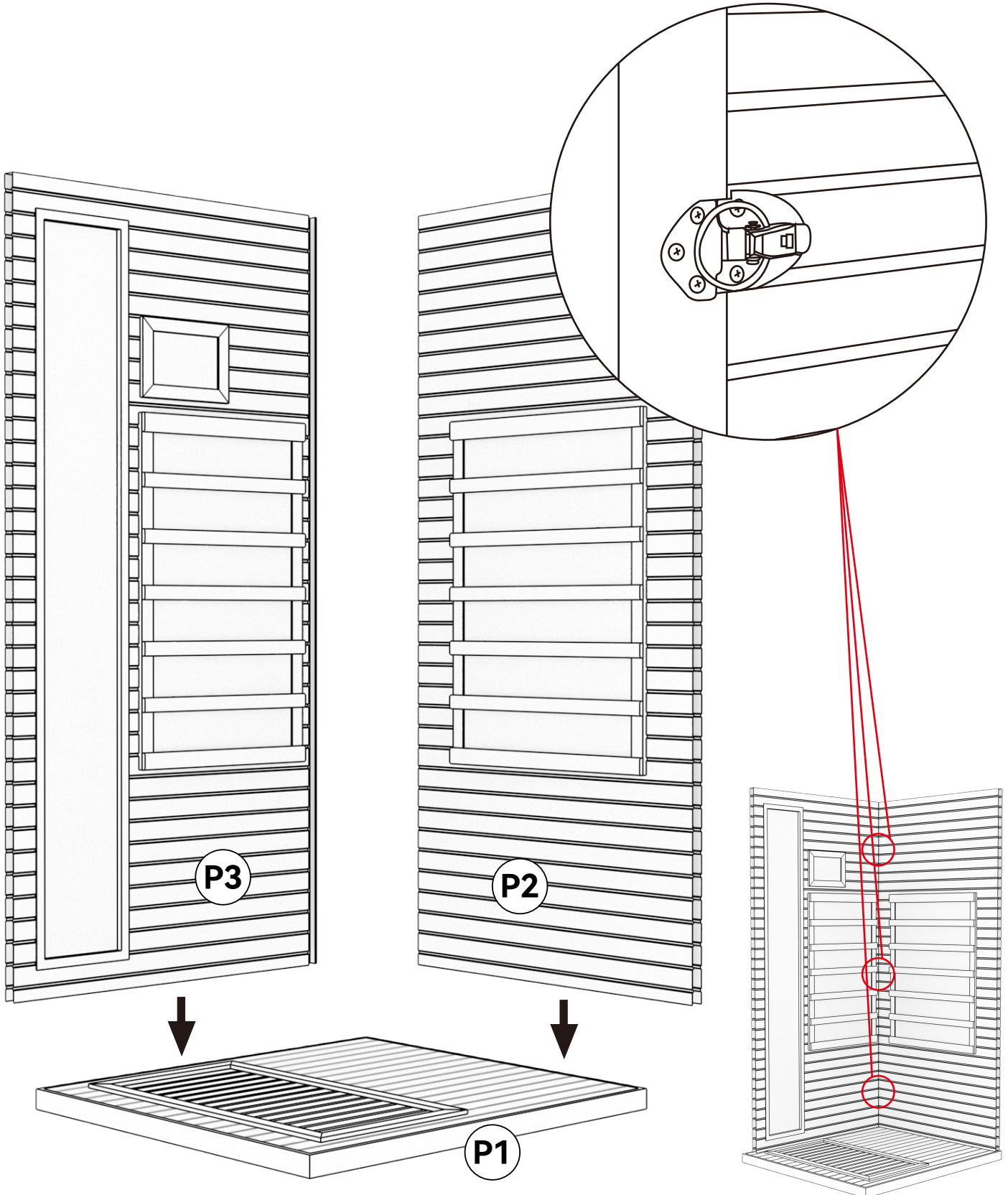

ASSEMBLY STEP

2

2. Connect part P5 to part P1 and part P3 respectively.

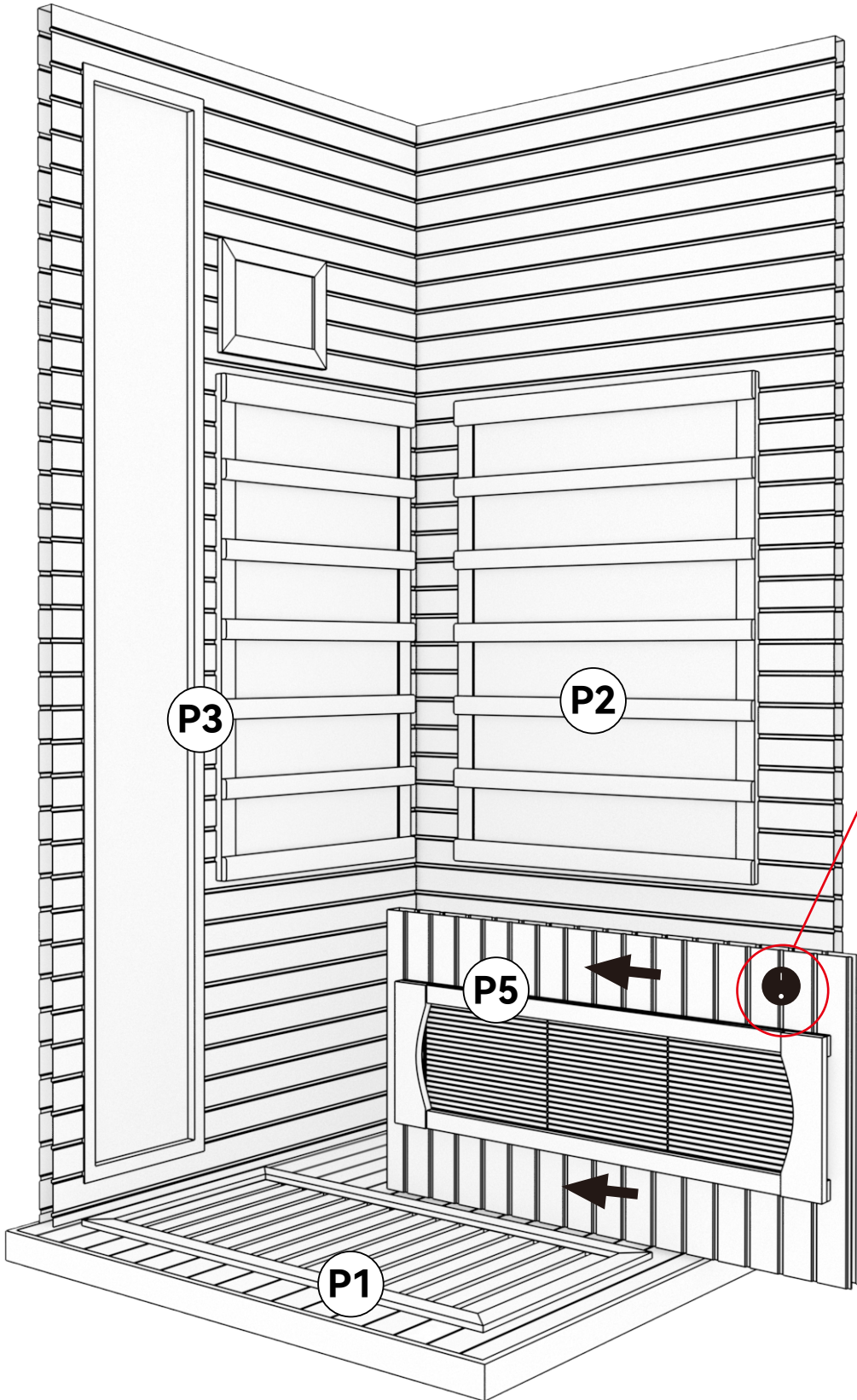

Individual On/Off switch on bench support, please switch the bench heater on or off at your request.

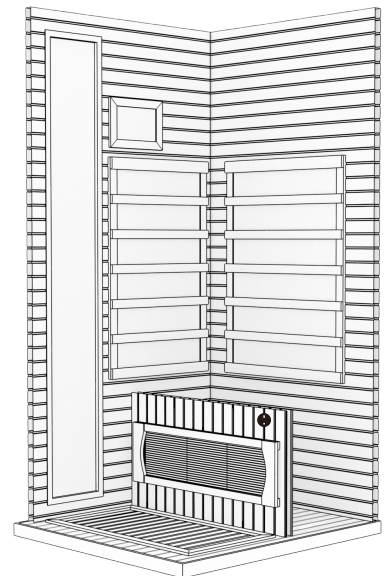

3. Place part P4 on the part P1.

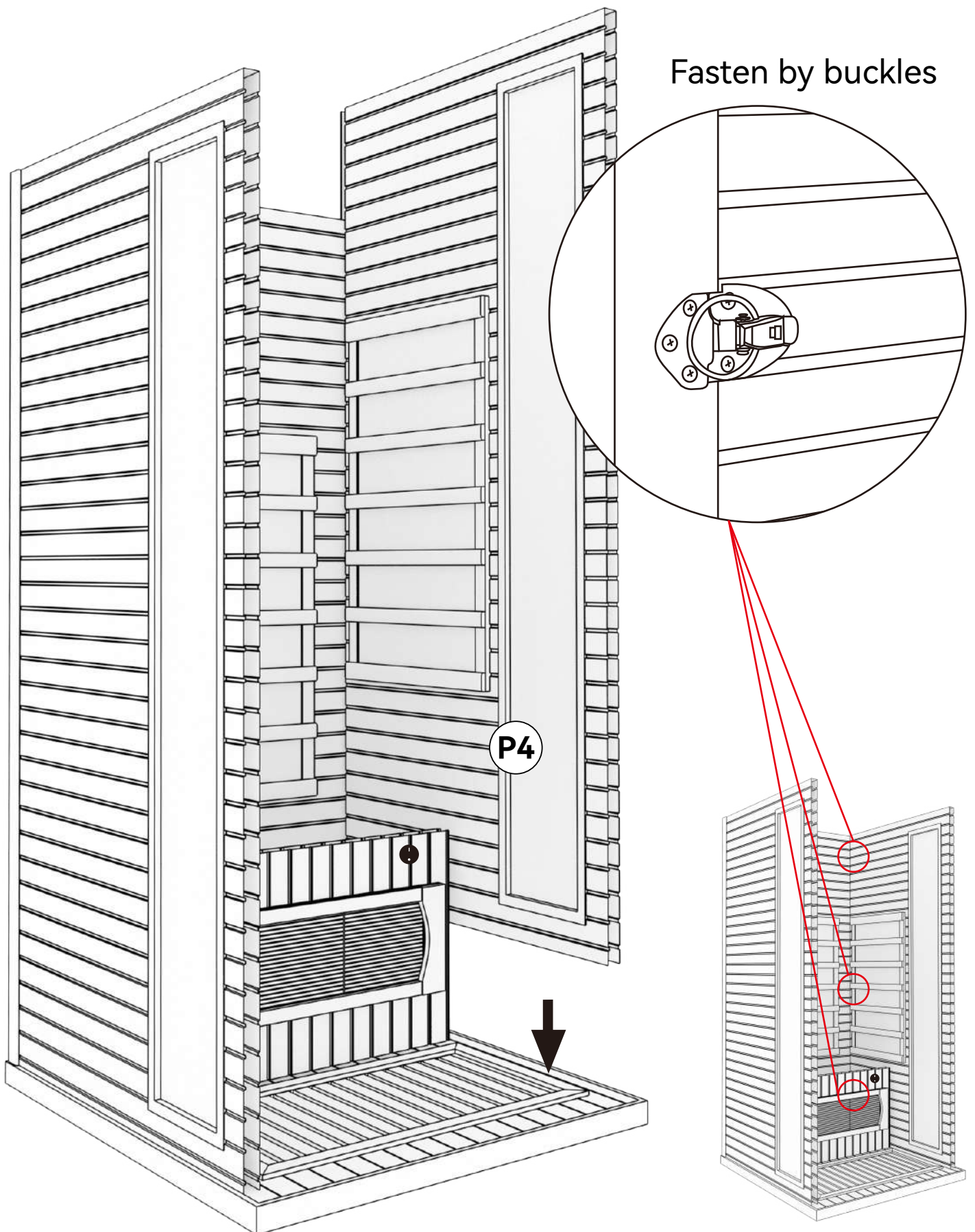

4. Connect the heating equipment of P1, P3, P4, P5 and P2.

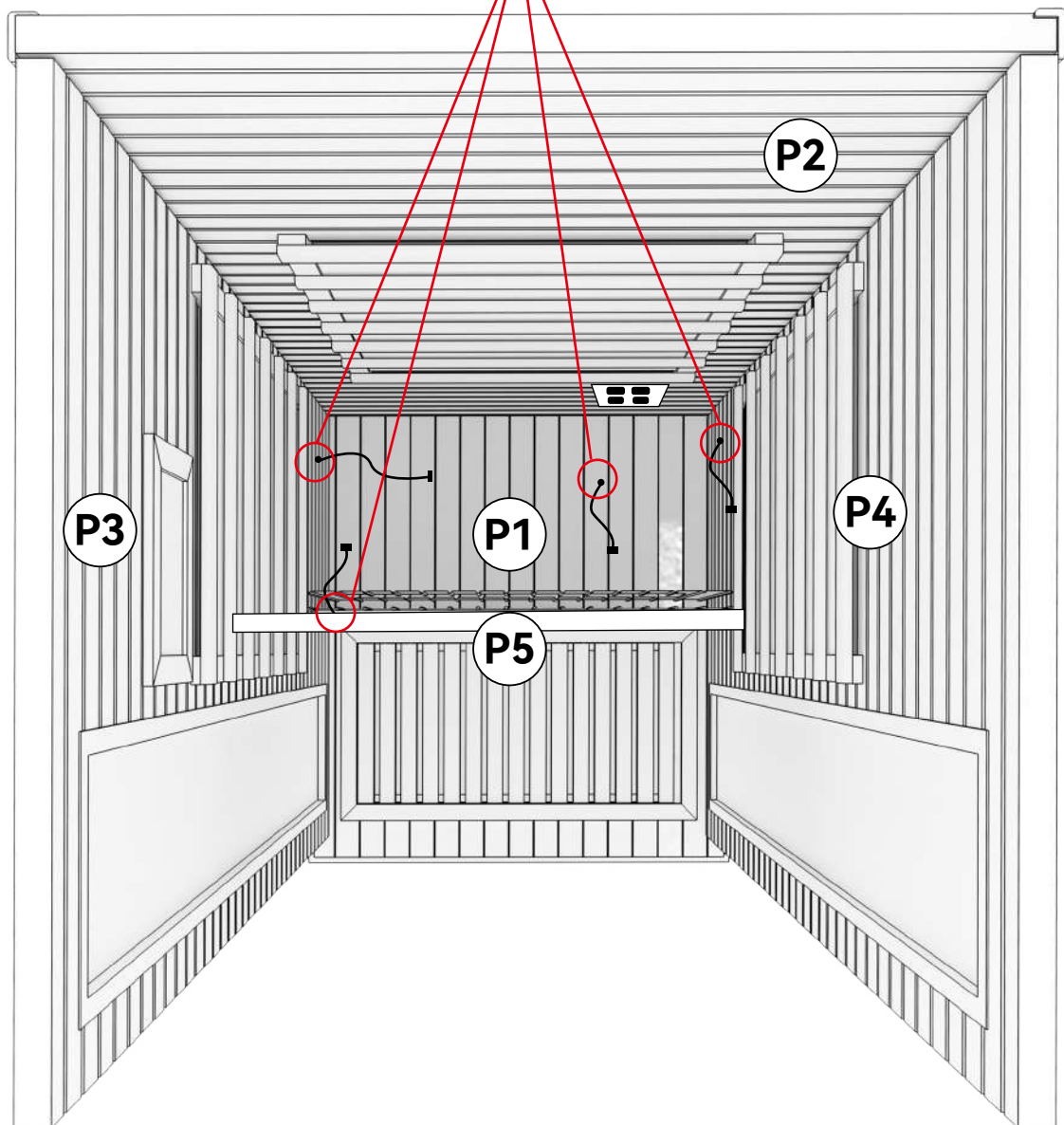
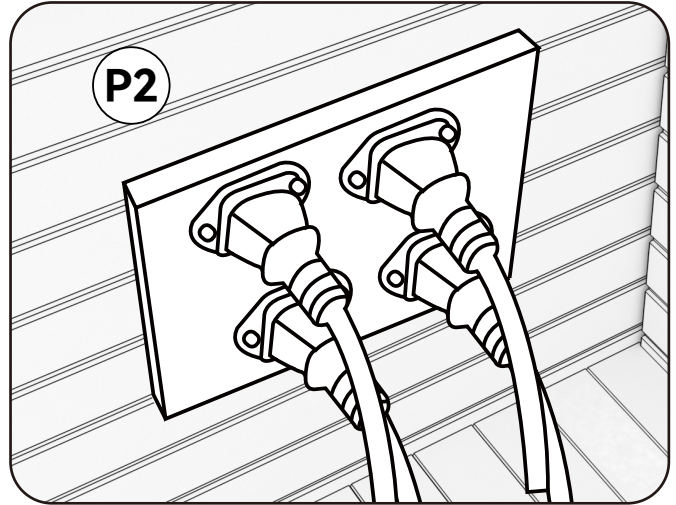
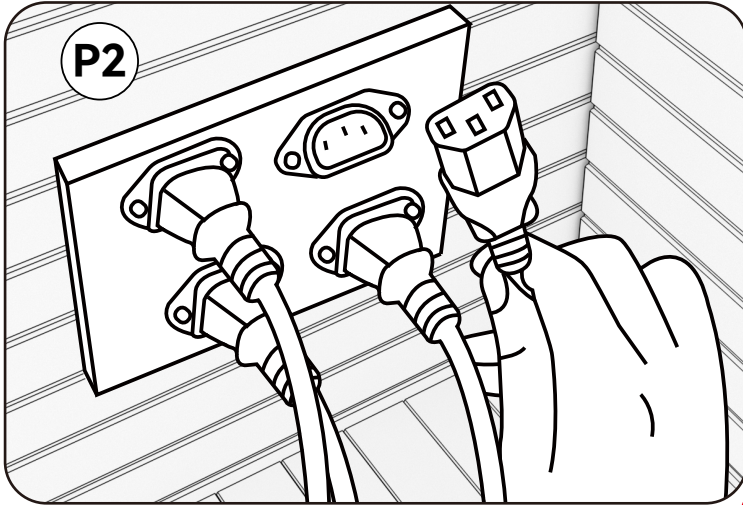

ASSEMBLY STEP

5

5. Insert part P6 into the groove of part P3 and part P4 respectively.

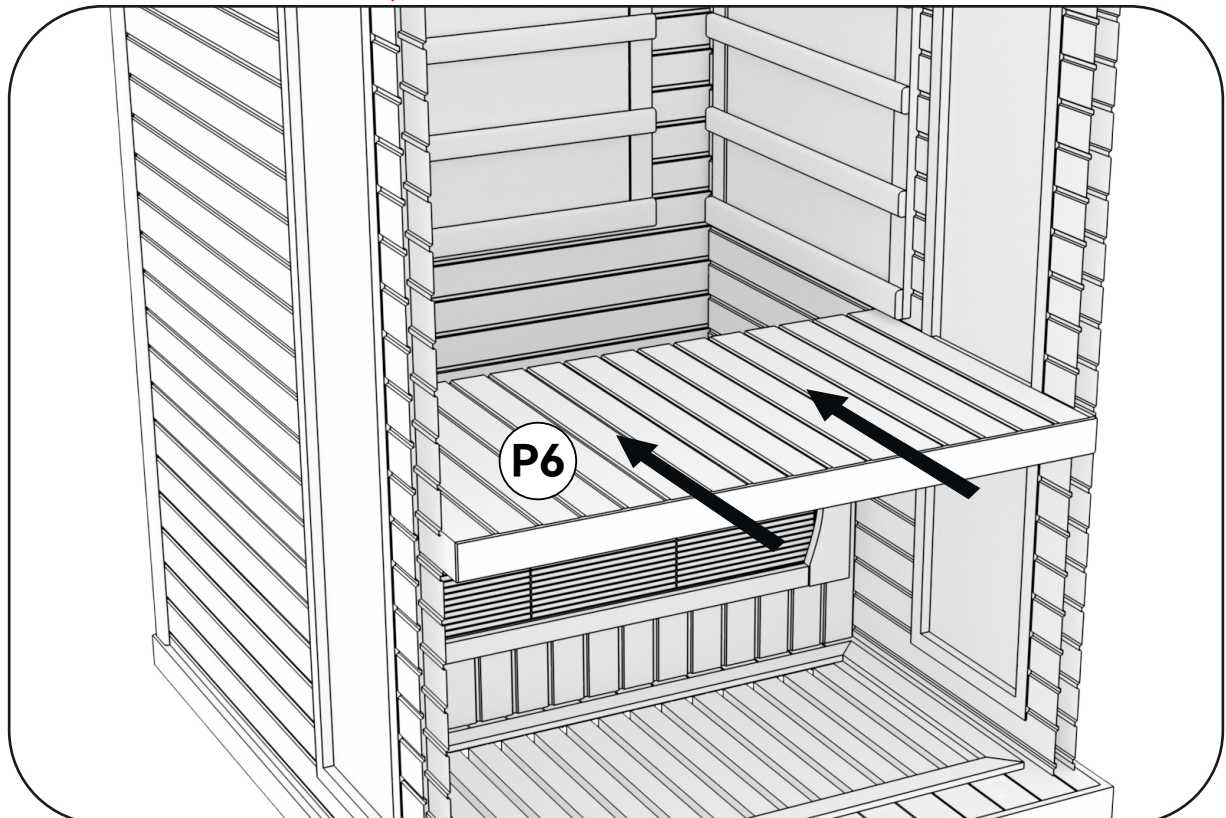
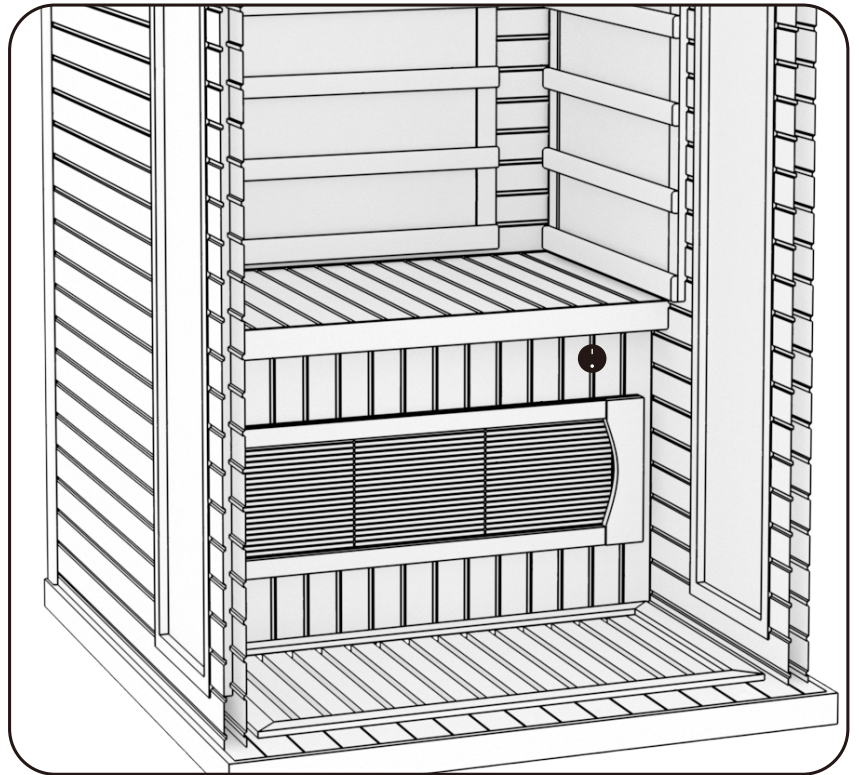
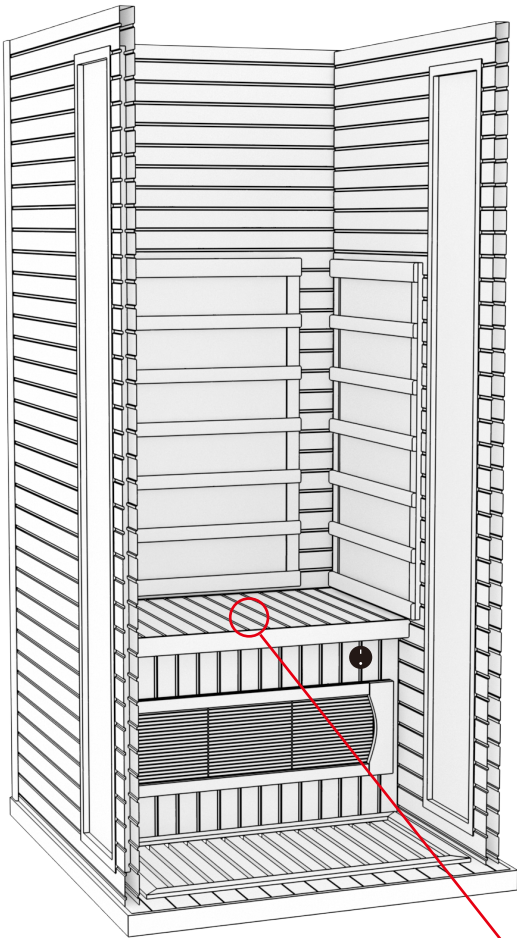

6. Install part P7.

Fasten by buckles

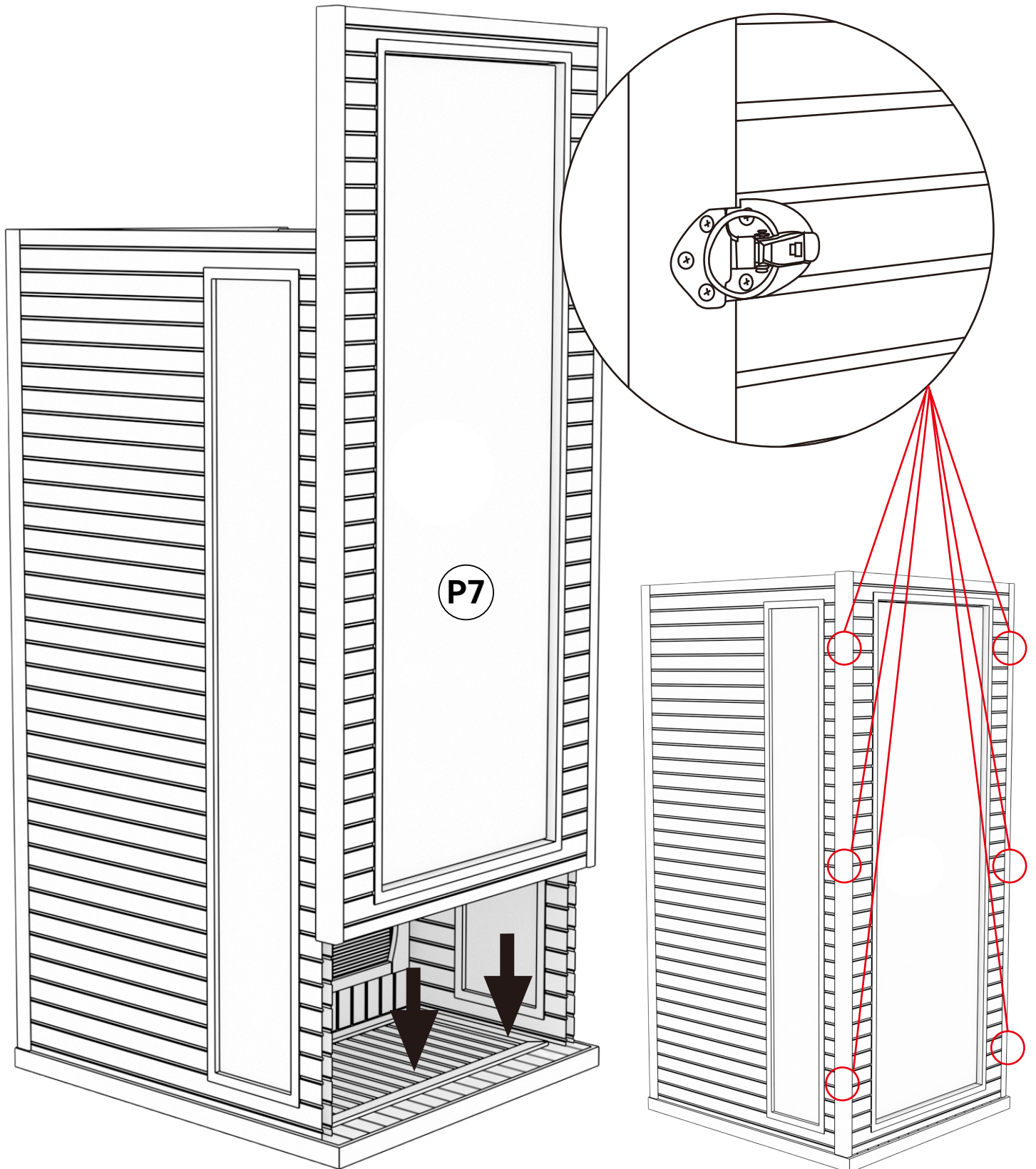

7. Install part P8.

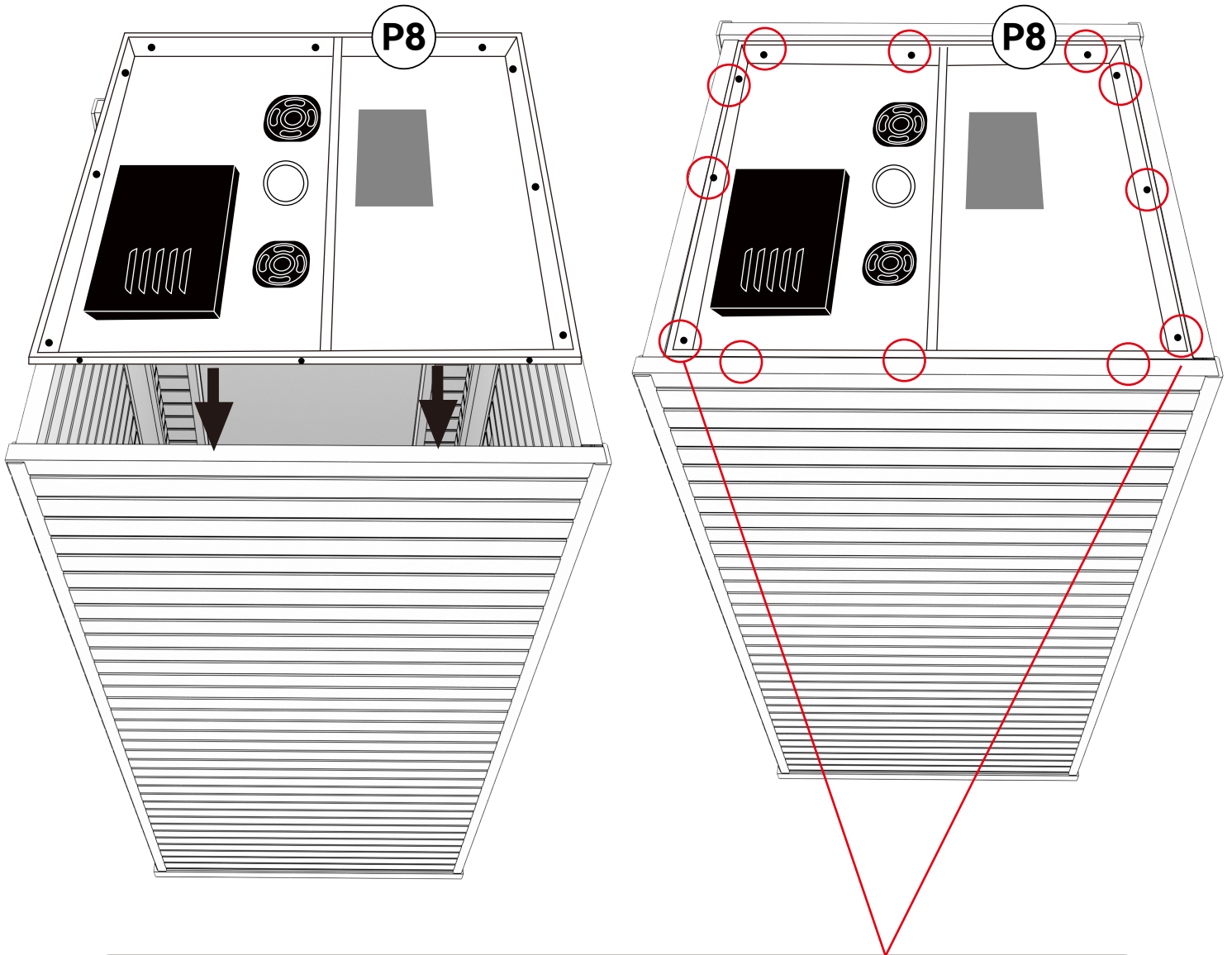

Fix the ceiling with rear, side, front panels via drilled holes with 3.5cm screws.

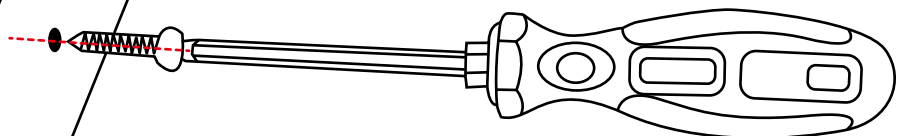

8. Please note the correct connections between the lines.

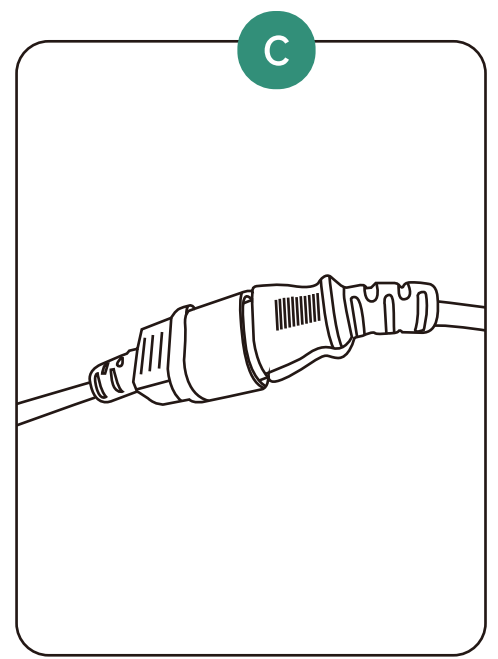
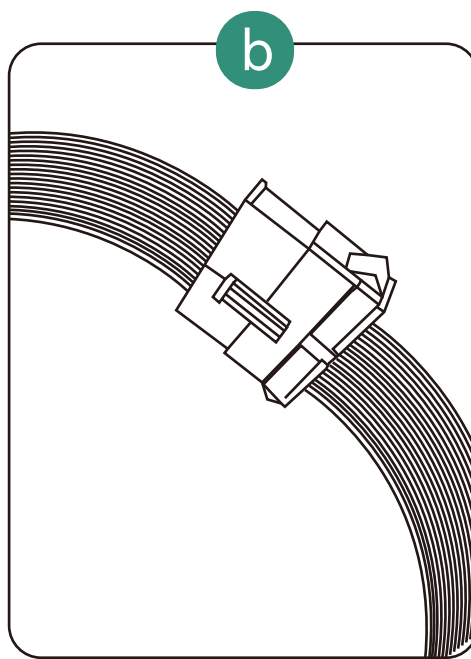
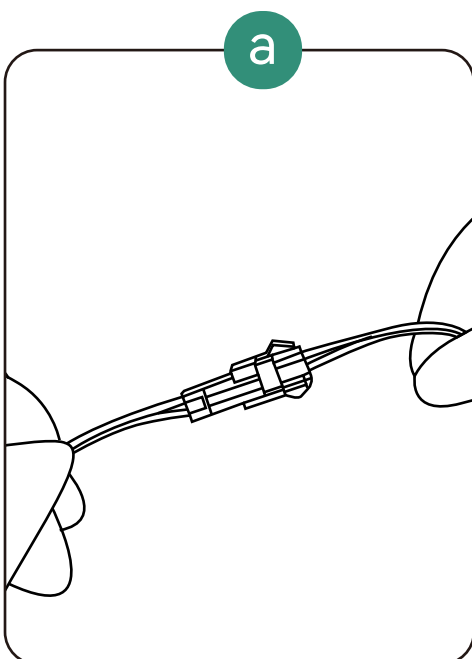
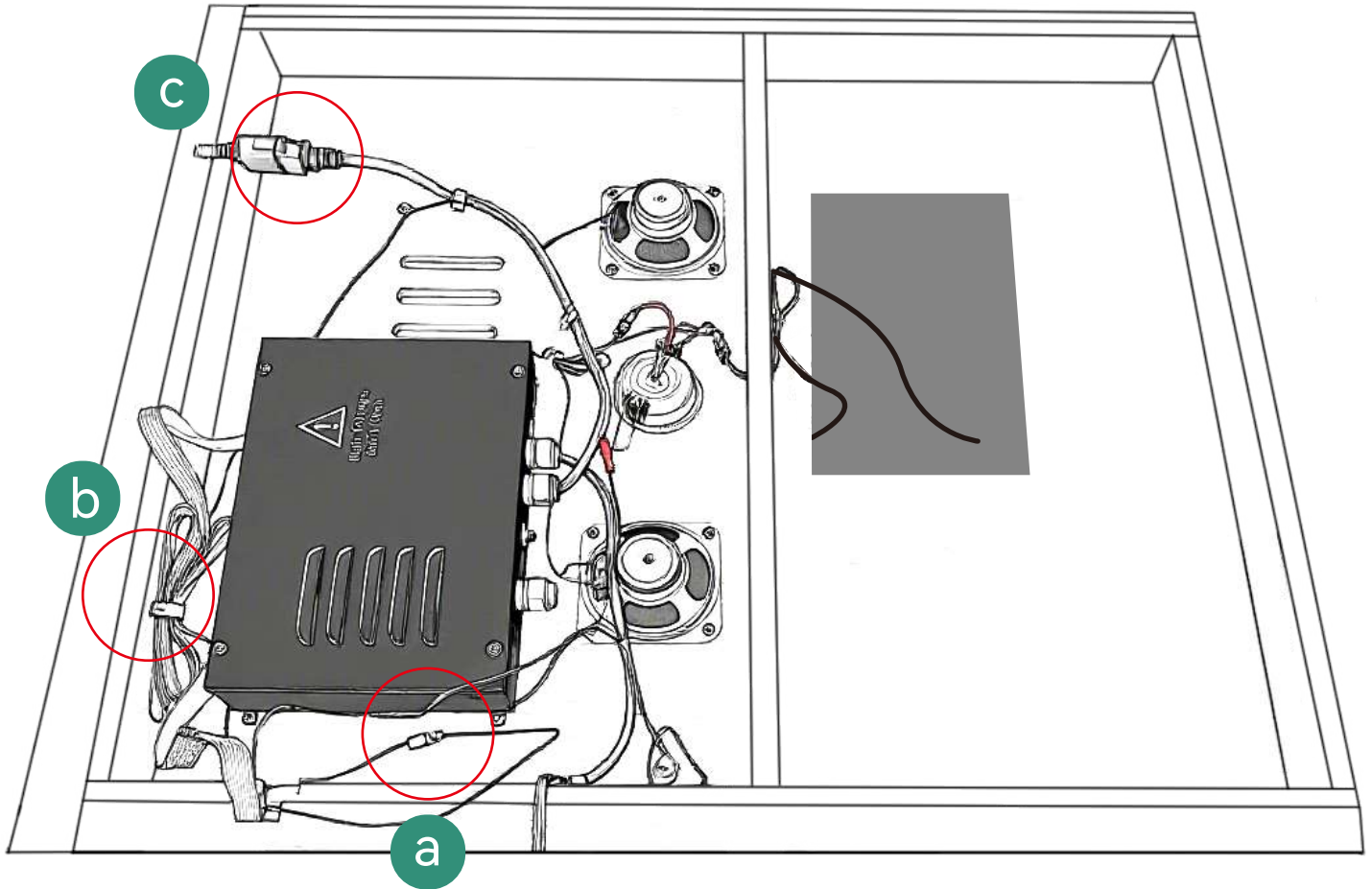

9. After assure everything works well, assemble Part Dust-proof cover on ceiling with 1.6cm screws.

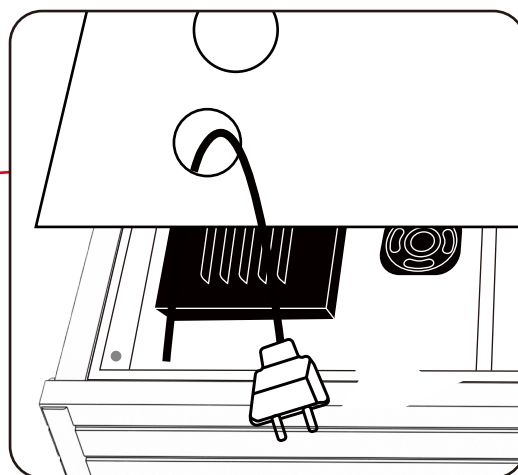
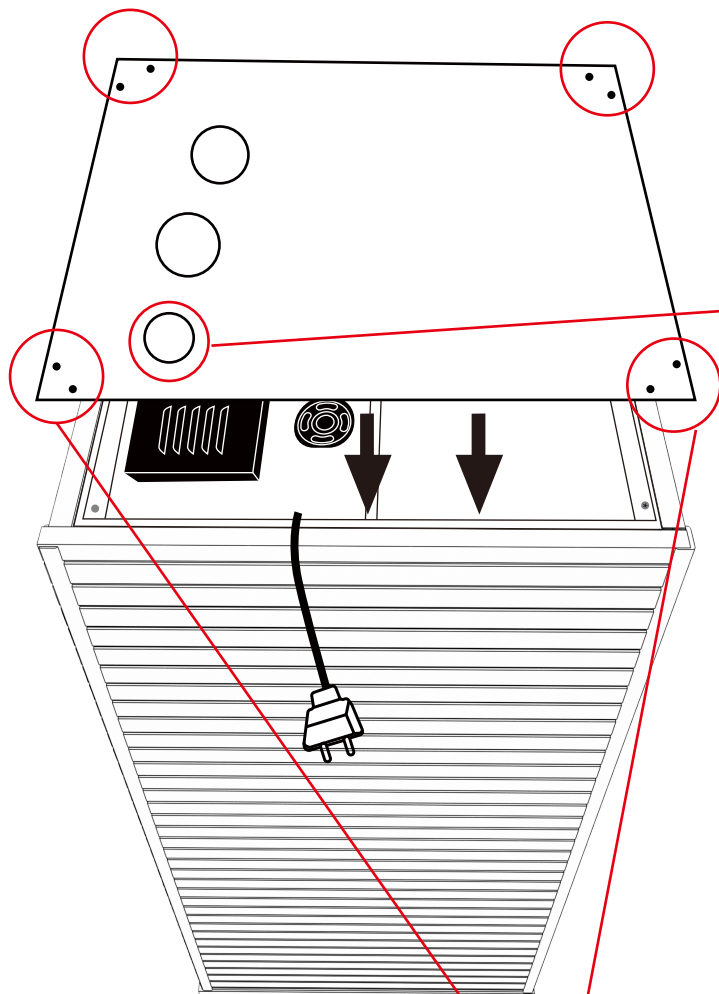

The main power cord passes through the hole on the dust cover.

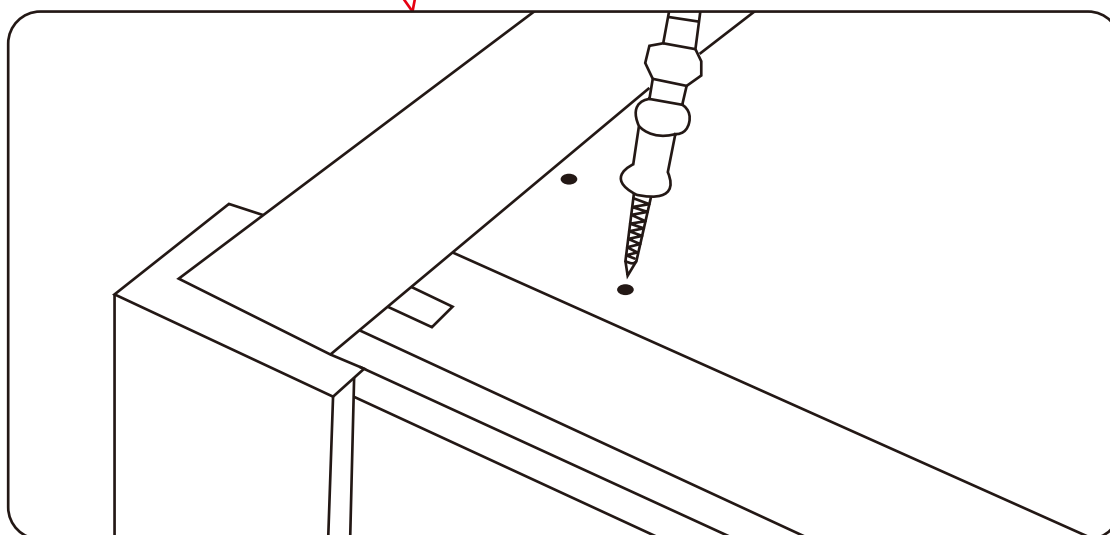

10. Install part P10

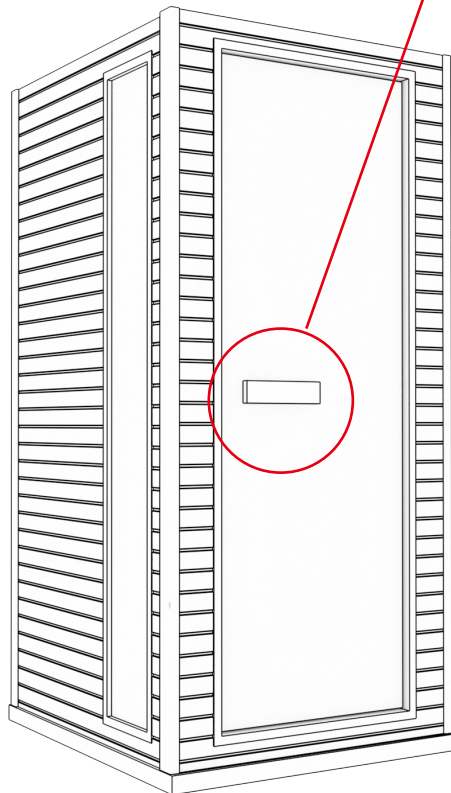
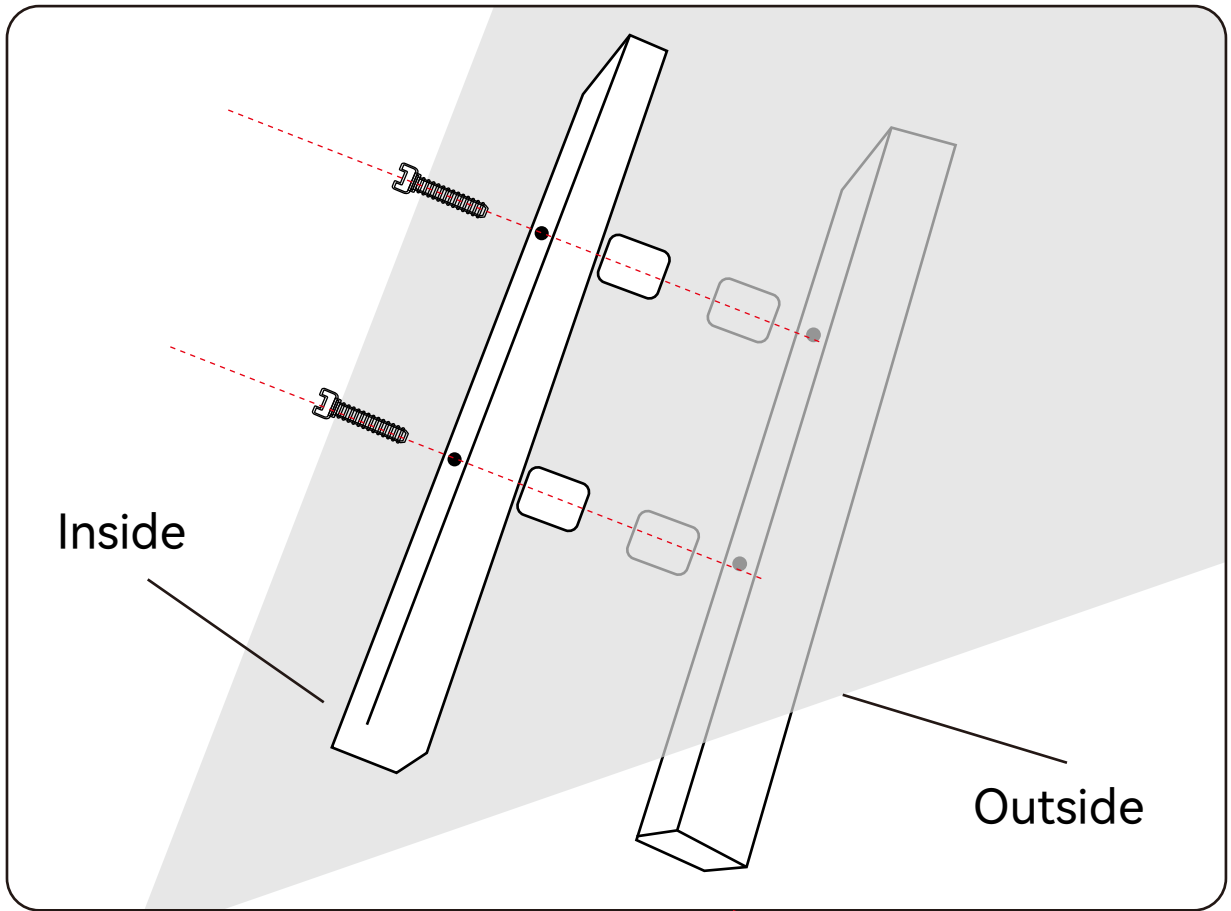

11. Install part P11.

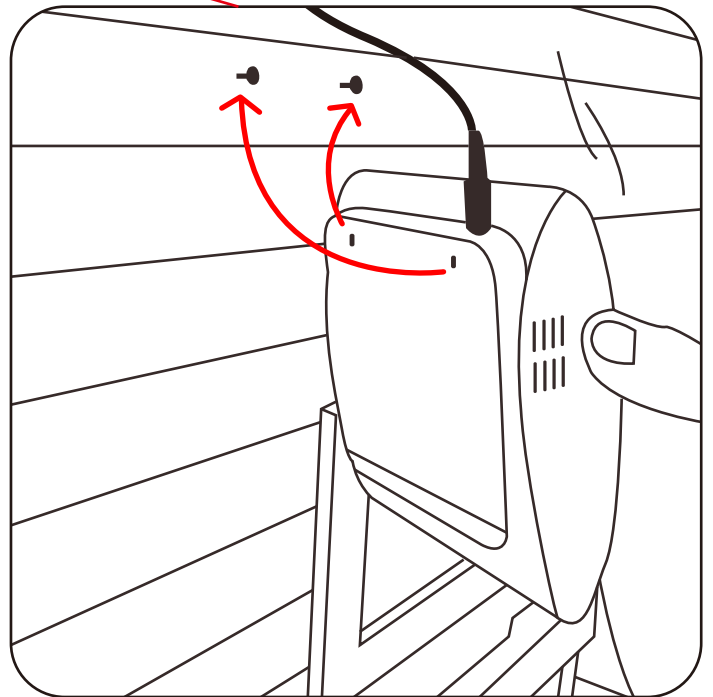
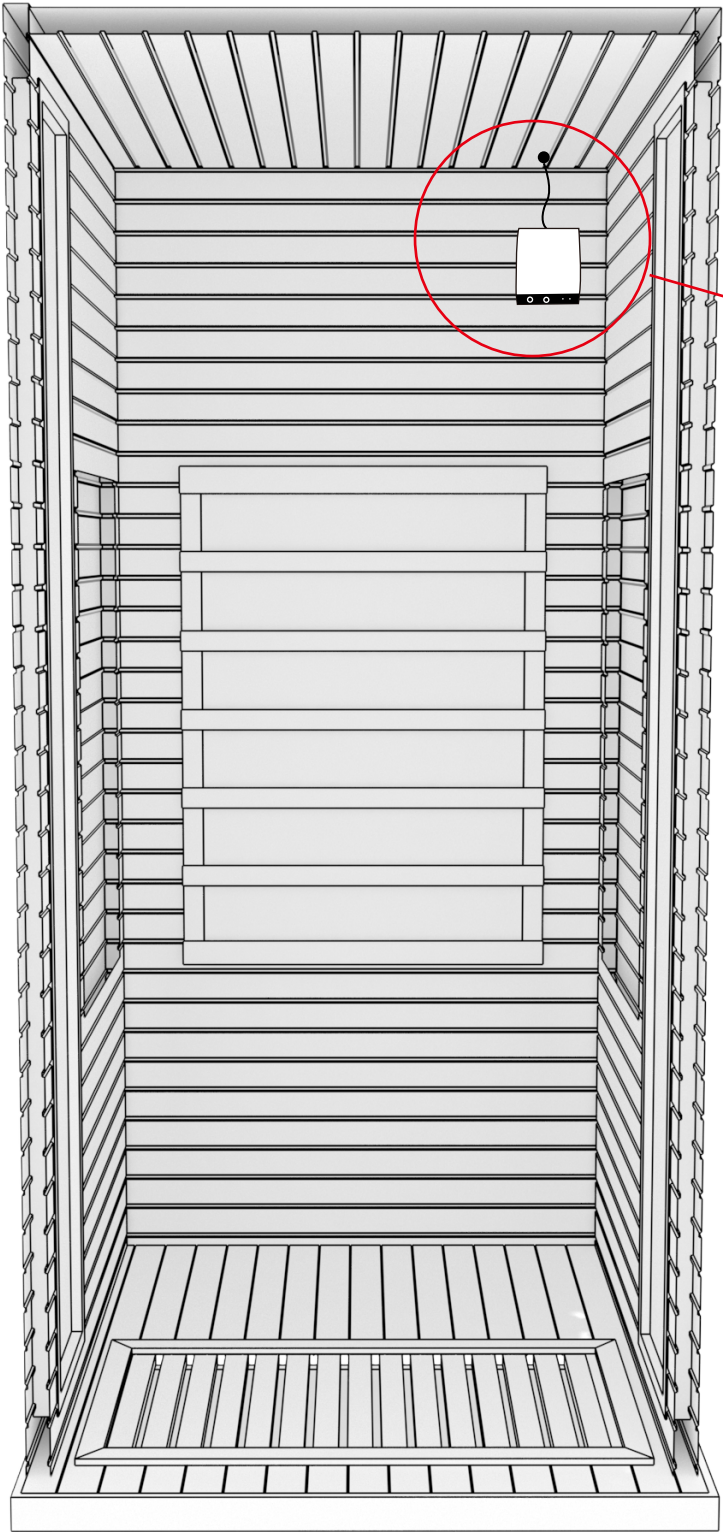

ASSEMBLY STEP 12

12. Cup holder Install the cup holders at your desired location with 2.5cm screws. Make sure not to install on or in front of the heaters.

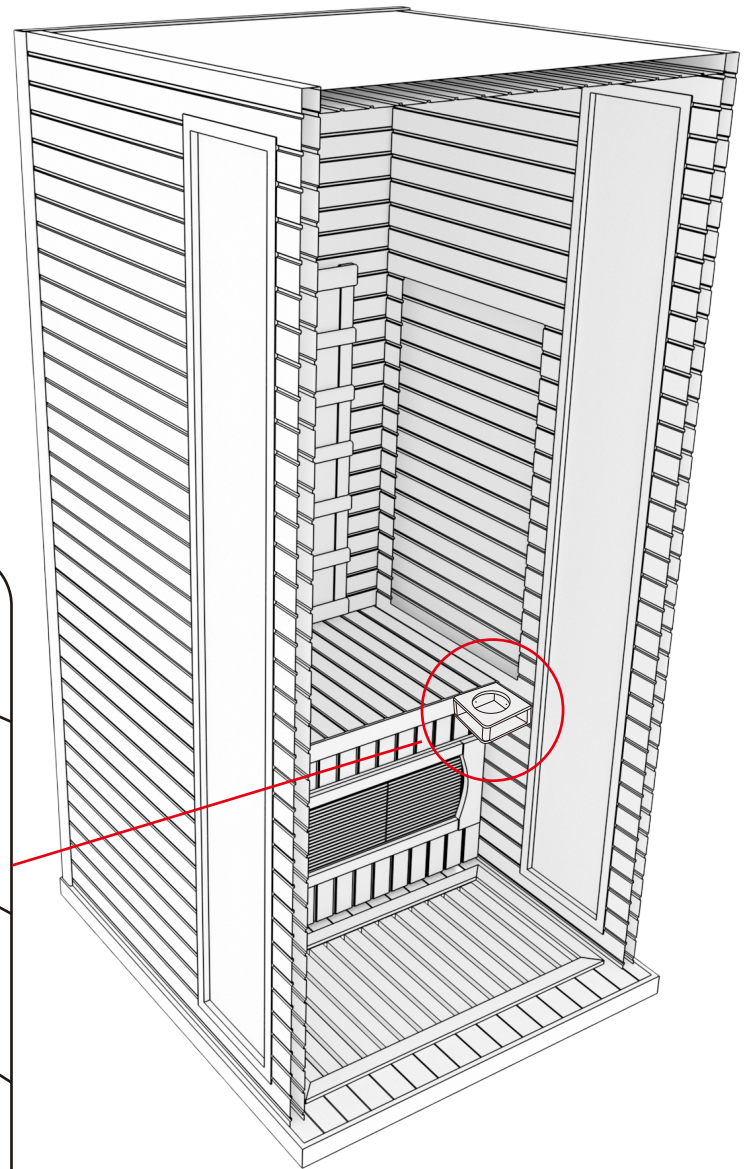
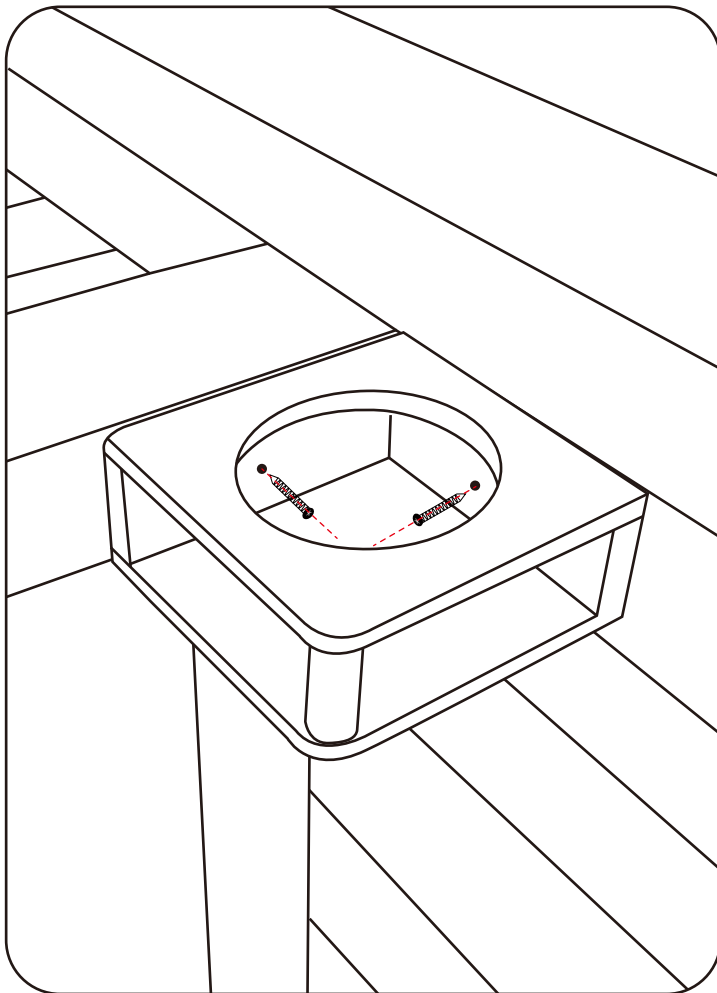

INSTALLATION SUCCESSFUL

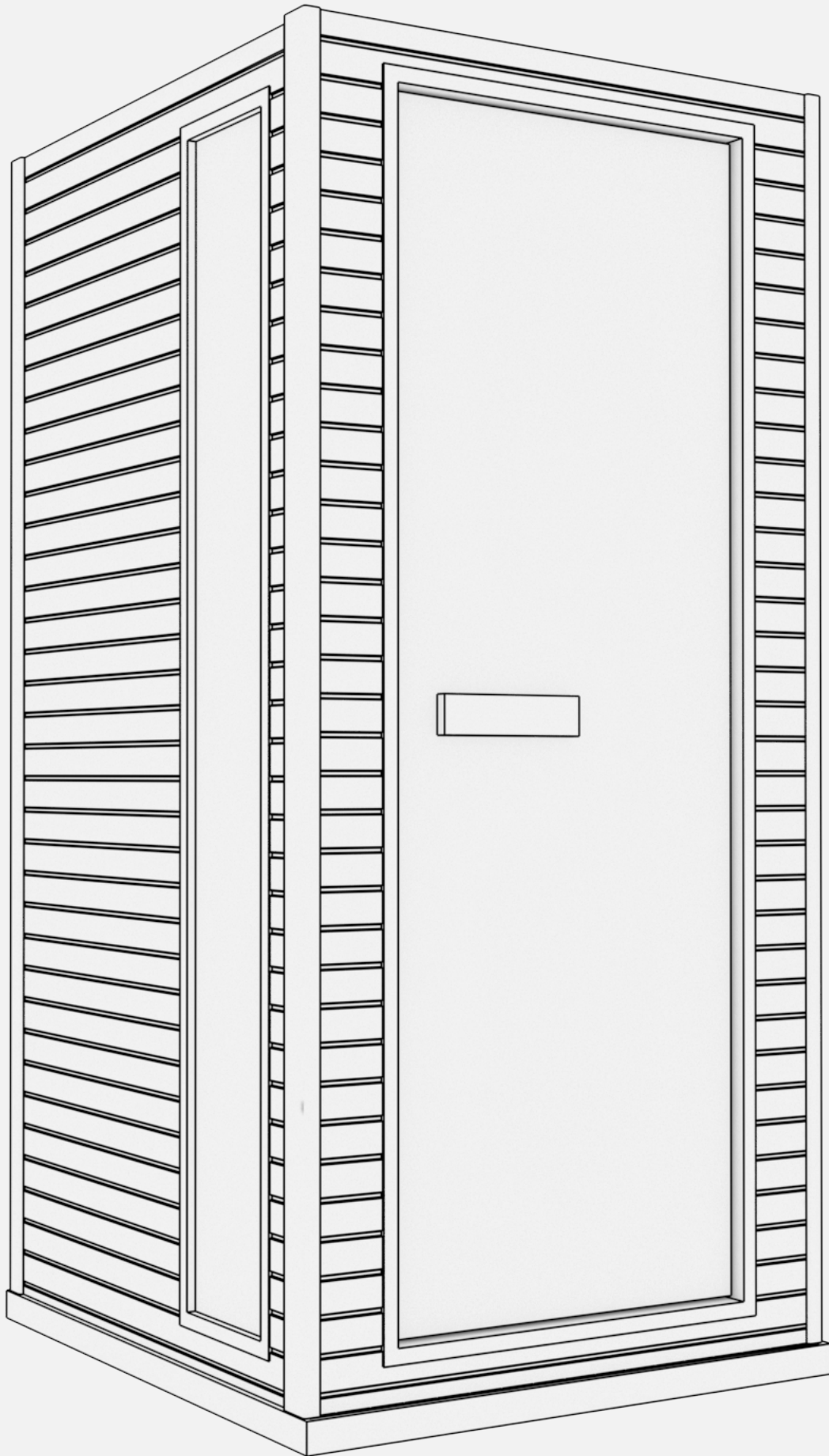

OPERATION INSTRUCTIONS OF CONTROL PANEL

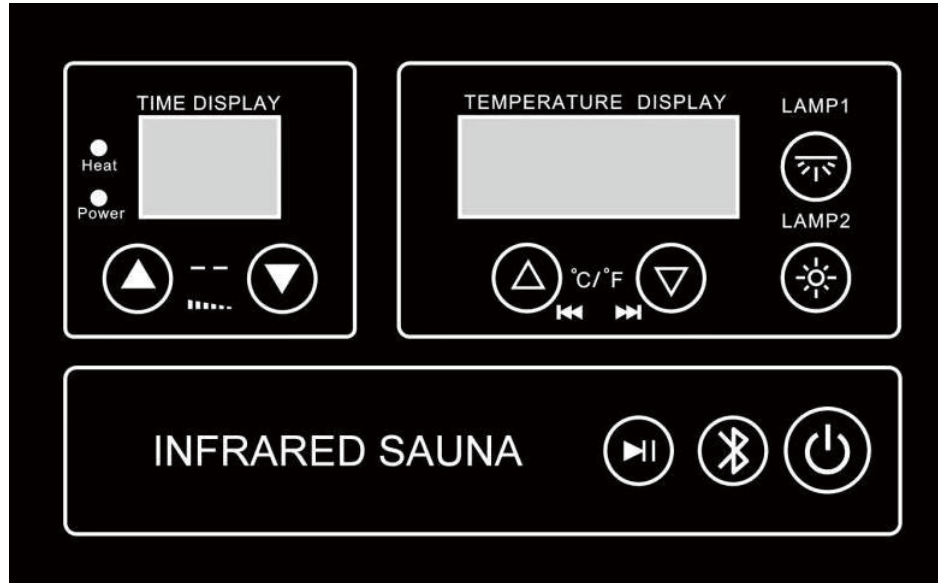

Power Button (On/Off)

This button turns the sauna on or off.



Bluetooth Button

Press this button to enter bluetooth mode, search for "Sauna BT" on your mobile phone and connect.

Tips:

1. Music playback can be controlled on control panel or mobile phone.
2. If there is no operation in bluetooth mode within 5 seconds, please press this button again, then adjust volume or change to the previous or next song.





Music Control (Play/Pause)

Press this button to pause or play when it is in bluetooth mode.









Time Button (Increase/Decrease)

Press  or  button to increase or decrease the sauna timer.

Tips:



1. Time setting ranges from 1 to 99 minutes.
2. The heaters will turn off when the timer counts down until 00.

OPERATION INSTRUCTIONS OF CONTROL PANEL





3. Press and hold both  and  buttons to switch off the timer (no time limit, it displays two dashes-- , utmost 4 hours). Press either  or  button to start the timer again.
4. Press  /  buttons to increase / decrease volume in bluetooth mode.



Temperature Button (Increase/Decrease)

Press  or  button to increase or decrease the sauna temperature.

Tips:

1. Temperature setting ranges from 15 to 65°C.
2. The heaters will turn off when the sauna reaches its desired temperature.
3. Press and hold both  and  buttons to switch the temperature display between Fahrenheit and Celsius.
4. Press  /  buttons to choose next or previous song in bluetooth mode.



Dual Light Button

Press the button shortly to switch on/off LED strips and change colors.

Tips:

It changes 7 colors; the 8th mode is auto color changes, the 9th mode is off status.

Press this button over 3 seconds to switch on/off LED beauty lamp.



Interior Light Button

Press this button to switch on/off interior LED spot light.

Tips:

The interior light is on status when the control panel is activated.

Error Code and Solutions

Error code EO: The temperature sensor doesn't connect well, reconnect it.

Error code E1: There is a short circuit, replace a new temperature sensor or circuit board.

USAGE GUIDE

Conditions to Use the Sauna

1. Temperature range: +5~+40°C (41-104°F degrees).
2. Relative humidity: ≤85%
3. Depression: 700-1060 hPa
4. Main supply: AC 110V or 220V-240V Frequency 50Hz ± 1 or 60Hz ± 1

Allow your sauna to warm up for 15-20 minutes or until it reaches 43°C (110°F degrees). You may close the vent on the ceiling to speed up the preheating process. Drink plenty of water to avoid dehydration during or after the sauna using. It is better not to exceed 40 minutes on time.

When you use the sauna, please switch on the oxygen ionizer. If you still feel stuffy, open the vent in the ceiling to allow fresh air into the sauna.

Tips:

- Start using the sauna within 10°C before it reaches the set temperature in order to receive the most benefits of the infrared heaters. For example, if you set the sauna to 52°C (125°F degrees), you'd better start using the sauna when it reaches 46°C (115°F degrees) or 2-3°C less.
- Customers reported an average use temperature of 52°C (125 °F degrees).

Precautions to Use the Sauna

- If the temperature becomes unbearable, decrease the temperature or shut off the sauna immediately.
- Do not use if pregnant or have serious inflammation, a fever, a communicable disease, acute bleeding, or intoxicated.
- Concern the temperature if using the sauna with the elderly or children. Children need adult to accompany when using the sauna.
- Do not consume alcohol or drugs when using the sauna.
- If using prescription drugs, please seek advice of a personal physician or a pharmacist.
- Individuals with cardiovascular conditions or problems (hypertension/ hypo tension), congestive heart failure, impaired coronary circulation, which might affect blood pressure, should exercise extreme caution when exposed to prolonged heat.
- Chronic diseases such as Parkinson's, Multiple Sclerosis, Central Nervous System Tumors and Diabetes with Neuropathy are conditions that are associated with impaired sweating.

USAGE GUIDE

The use of Infrared saunas should be avoided by anyone who is predisposed to bleeding.

- An individual that has insensitivity to heat should not use any type of sauna.
- Heating of the low back area of women during the menstrual period may temporarily increase their menstrual flow.
- If have a recent acute joint injury, it should not be heated for the first 48 hours after an injury or until the hot and swollen symptoms subside.
- Metal pins, rods, artificial joints or any other surgical implants should consult a surgeon prior to using an Infrared Sauna.
- Do not splash water on the heaters or any electrical component inside the sauna.
- Do not bring wet towels into your sauna or any substances that could harm the interior of your sauna.
- Do not install a lock on your sauna.
- All repairs need to be authorized by the supplier's representative; otherwise product warranty may be voided.

In the rare event, you feel painful and/or uncomfortable, immediately discontinue sauna use.

Cleaning and Maintenance

- Use a clean damp towel to wipe off the bench, floor and around the back panel.
- Do not use a towel that is too wet and can drip water inside the sauna and do not use cleaning agents inside the sauna.
- Make sure to keep the sauna dry and clean. Do not leave towels or water glasses or bottles inside the sauna after use.
- Wipe the exterior surface of the sauna with a towel and clean the glass at least once a month.

Wood Care

- If the sauna exterior body was scratched or scuffed, it can be concealed by using a small amount of furniture polish, oil or other furniture treatment.
- The interior blemishes, scratches, or scuffs can be either left alone, sanded or combination of gluing plus sanding.
- Please avoid any treatment containing benzene or a high concentration of alcohol.

TROUBLESHOOTING

The sauna does not power on

- Make sure the power cord of sauna is connected to the socket at your home.
- Make sure the power cord of sauna is connected well to the power box on the top of sauna.
- Make sure the overload protector did not turn off.
- Make sure the control panel wire is connected.
- Make sure the power socket at your home is working by trying a different device on the same socket.

LED beauty lamp does not work

- Make sure the wires are connected well.
- Replace a new lamp.

LED Reading Light does not work

- Make sure the wires connected well.
- Replace the light bulb.

Color therapy light does not work

- Make sure the wire is inserted into the power box correctly.
- Replace a new therapy light.

One or a few heaters do not work

- Make sure the heaters'plugs are connected on top of the sauna.
- Make sure the heaters'plugs under the bench are connected.
- Floor heater is not as hot as other heaters (by design).
- Make sure the plug behind the heater is connected (you would need to unscrew the heater).
- Replace a new heater.

TROUBLESHOOTING

The sauna temperature does not rise up normally

- Make sure all the heaters work well.
- Make sure temperature sensor works well.
- Make sure time and temperature set correctly on control panel.

LED strip does not work

- Make sure the wires are connected well.
- Replace a new LED strip.

Power box makes abnormal beeps

- There is something wrong on the relays,replace a new circuit board.
- Replace a transformer.

Oxygen ionizer does not work

- Make sure the cable is connected well in the power box and with the ionizer well.
- Replace a new ionizer.
- Replace a new cable.

For more troubleshooting advice or to report a problem, please contact with your supplier.

EROMMY!

Closer to Life!

