

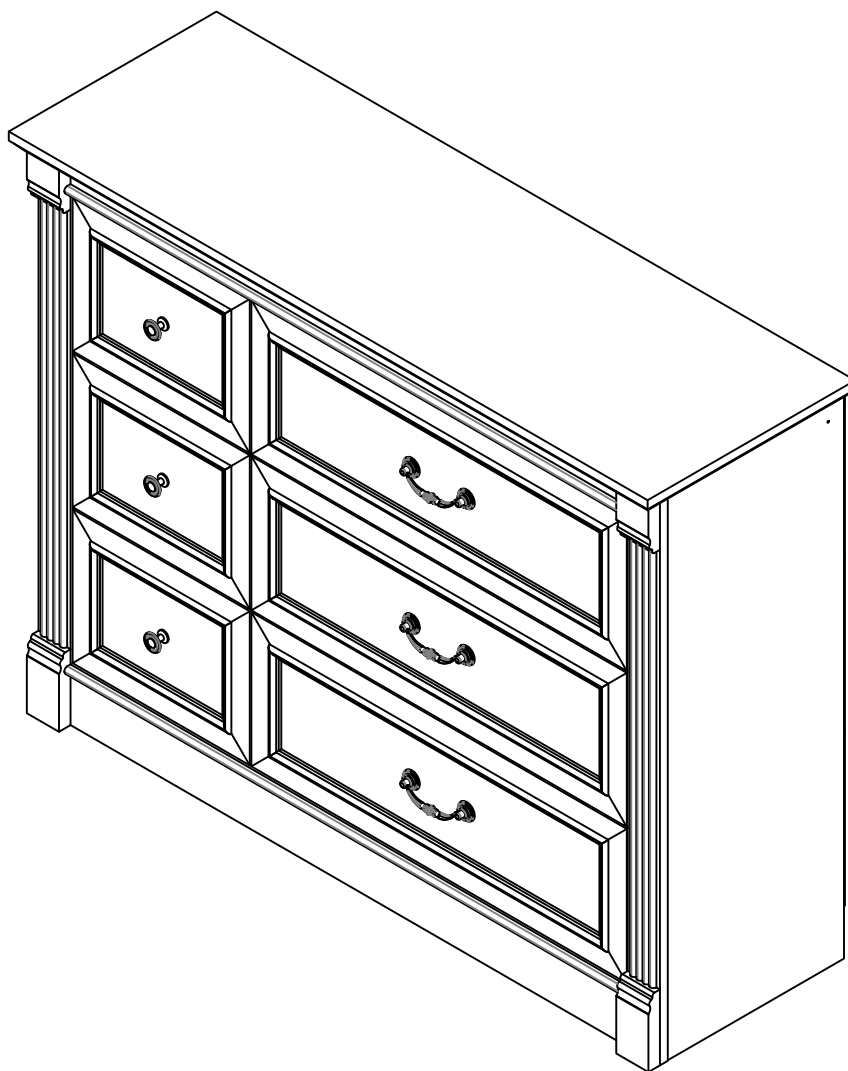

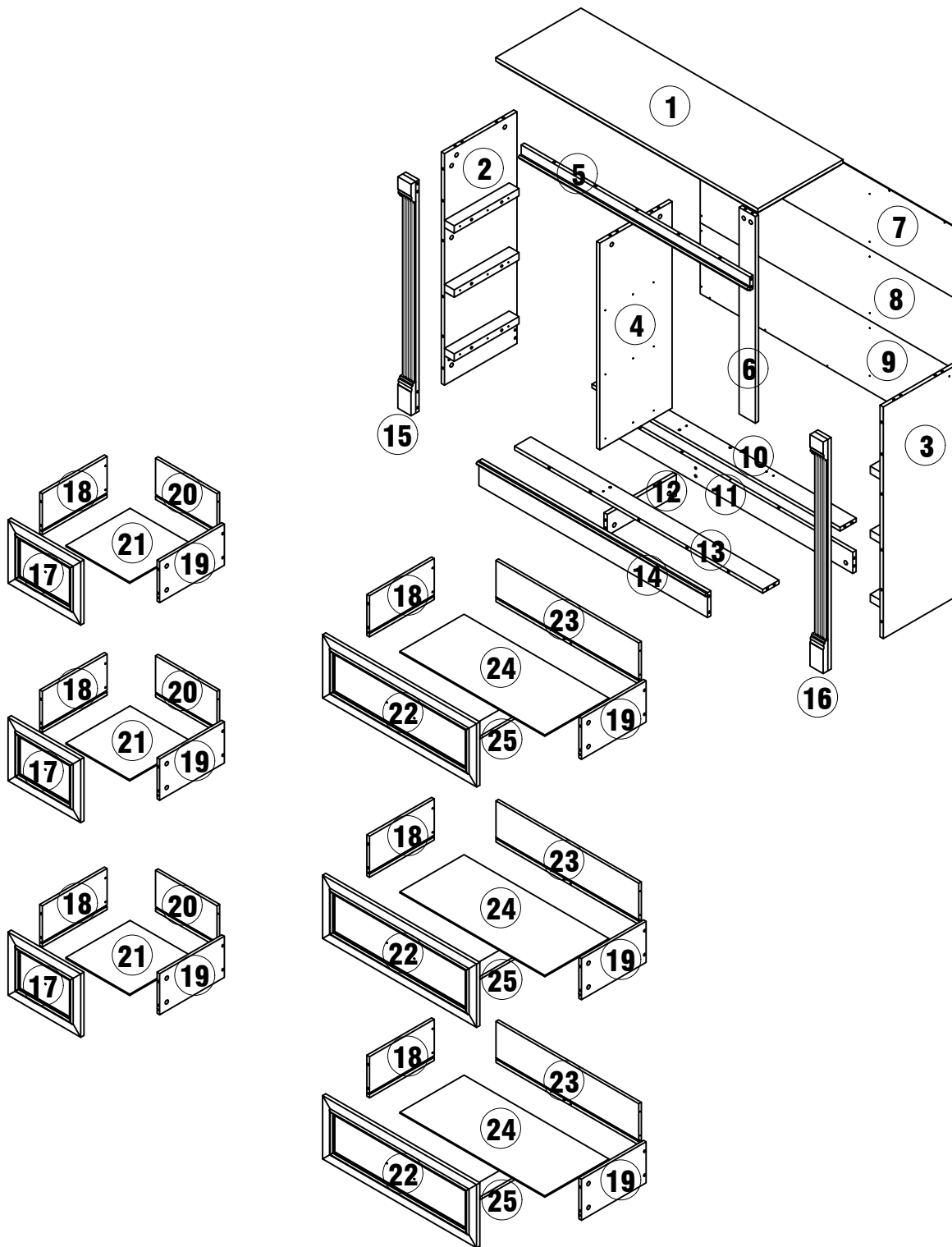





# ASSEMBLY INSTRUCTIONS

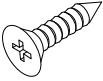
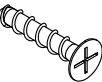

# PACKAGE INCLUDE

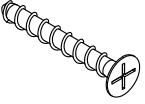

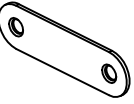
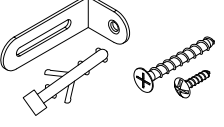
# PACKAGE CONTENT

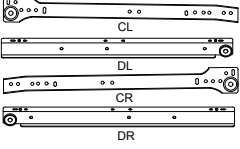
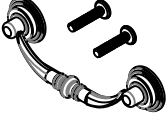
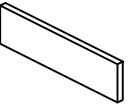
|   |  |  |  |
|---|--|--|--|
| <p><b>Ø8X30MM</b></p>  <p><b>A</b>                      <b>34X+2</b></p> | <p><b>Ø3X12MM</b></p>  <p><b>B</b>                      <b>60X+3</b></p>    | <p><b>Ø4X35MM</b></p>  <p><b>C</b>                      <b>30X+1</b></p> |  <p><b>D</b>                      <b>3X</b></p>   |
| <p><b>Ø4X50MM</b></p>  <p><b>E</b>                      <b>7X</b></p>    | <p><b>Ø3.5X12MM</b></p>  <p><b>F</b>                      <b>42X+2</b></p>  |  <p><b>G</b>                      <b>4X</b></p>                          |  <p><b>H</b>                      <b>2X</b></p>   |
|  <p><b>J</b>                      <b>57X+2</b></p>                     | <p><b>Ø15X10MM</b></p>  <p><b>K</b>                      <b>57X+2</b></p> |  <p><b>L</b>                      <b>6X</b></p>                        |  <p><b>M</b>                      <b>3X</b></p> |
|  <p><b>N</b>                      <b>8X</b></p>                        |  |  |  |

# How to use the cam lock system

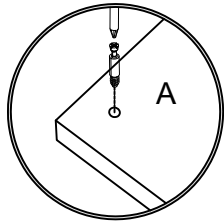

1. Screw cam bolt into panel

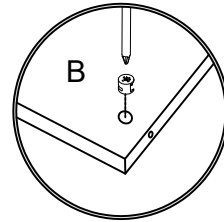

2. Push cam into panel - arrow feature on cam top points to panel edge

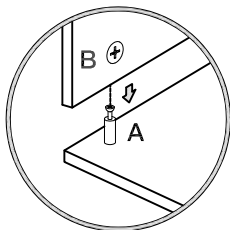

3. Align cam bolt(s) with cam(s) and insert all the way into cross-bored hole(s)

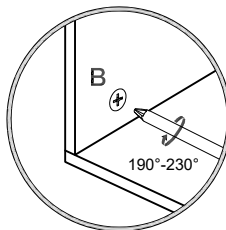

4. Rotate cam(s) clockwise 190°-230° to lock panels together

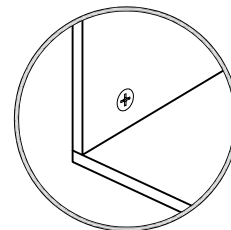

5. Panels should be tight against each other and connection should be rigid

Insert the wood dowel [C] at least half way by tapping lightly with a rubber mallet, IF NECESSARY.

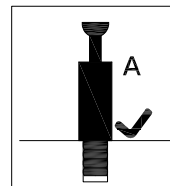
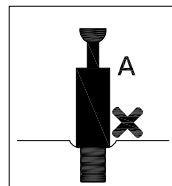
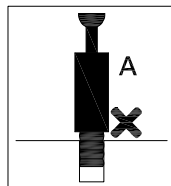
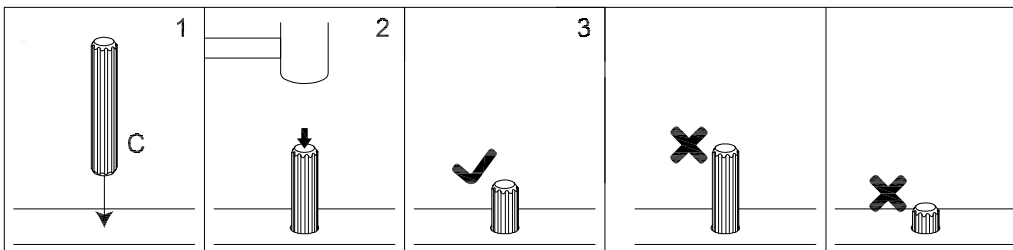

## **⚠ WARNING**

- Unit must be placed on a level surface or leveled with included hardware (when applicable).
- Do not sit or stand on or allow children to climb, sit or stand on the assembled product.
- For safety reasons, it is imperative that this unit be mounted to the wall.
- Do not use without installing the tip restraint.
- Unit can tip over causing severe injury or death.
- Do not exceed the recommended weight limits.
- Evenly distribute the weight on each level and always keep the heavier loads on the bottom.
- Before cutting, drilling or hammering into any wall or floor surface, verify the location of electrical, plumbing and gas lines. Cutting may cause serious injury.

# STEP 1

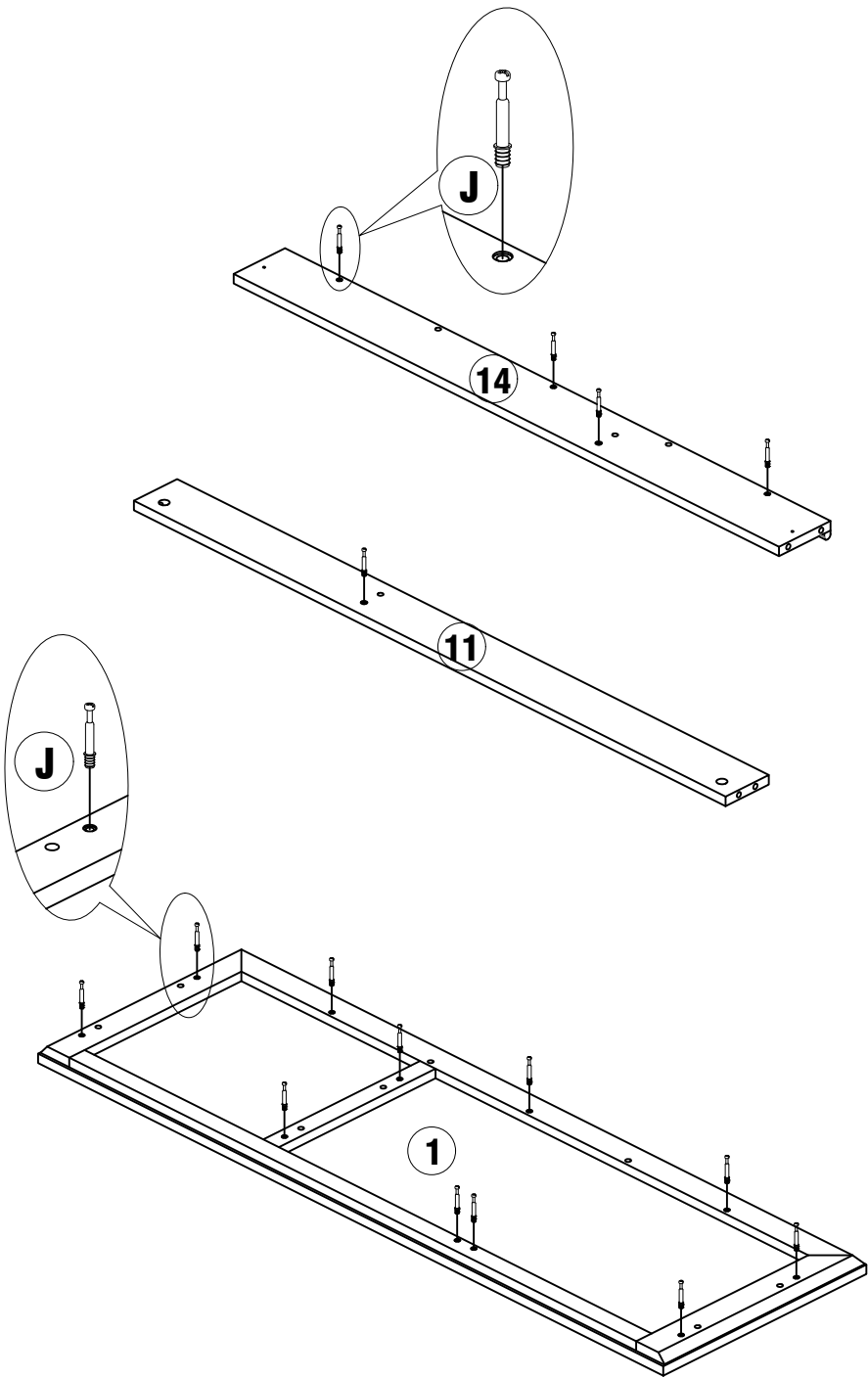
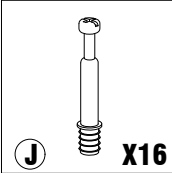

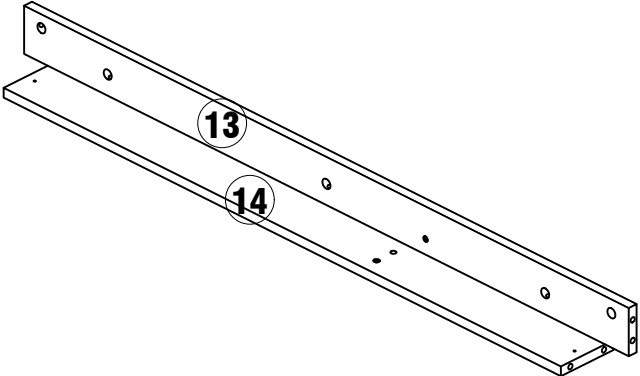
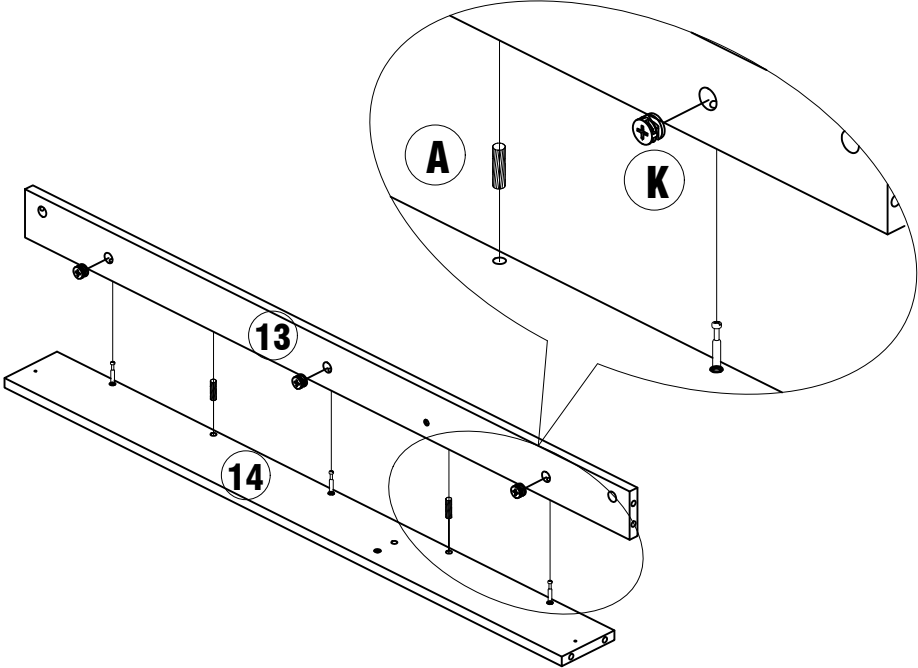
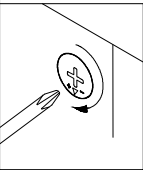
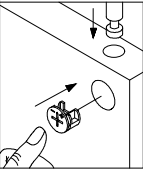
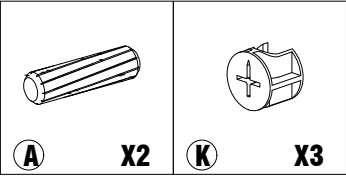

# STEP 2

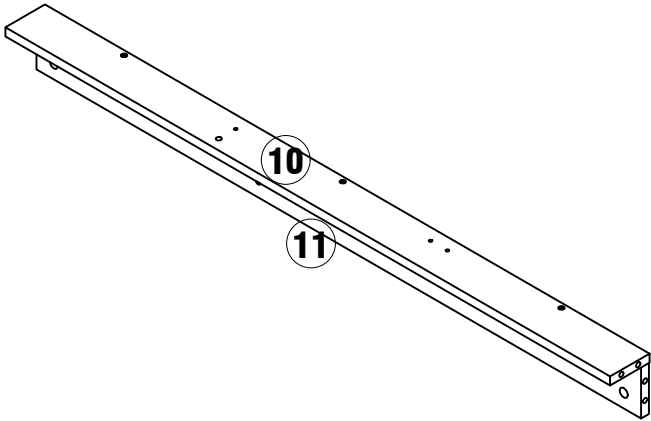
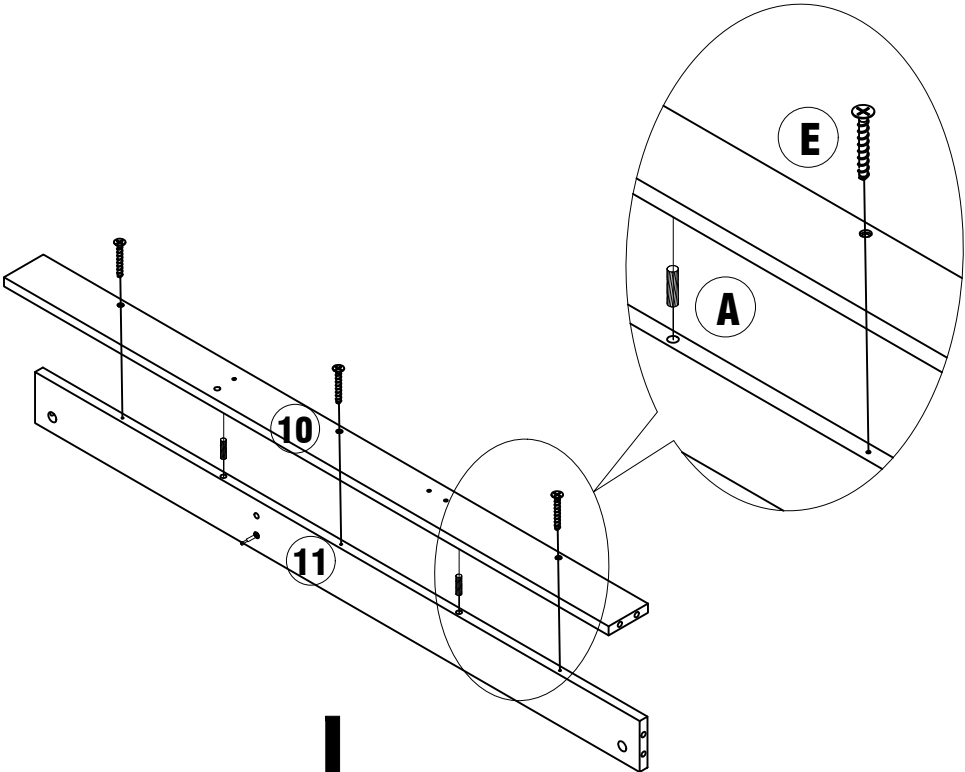
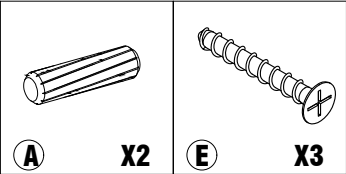

# STEP 3

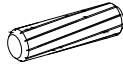

# STEP 4

|   |   |
|---|---|
|  |  |
| <b>A</b> <b>X2</b>  | <b>K</b> <b>X2</b>  |

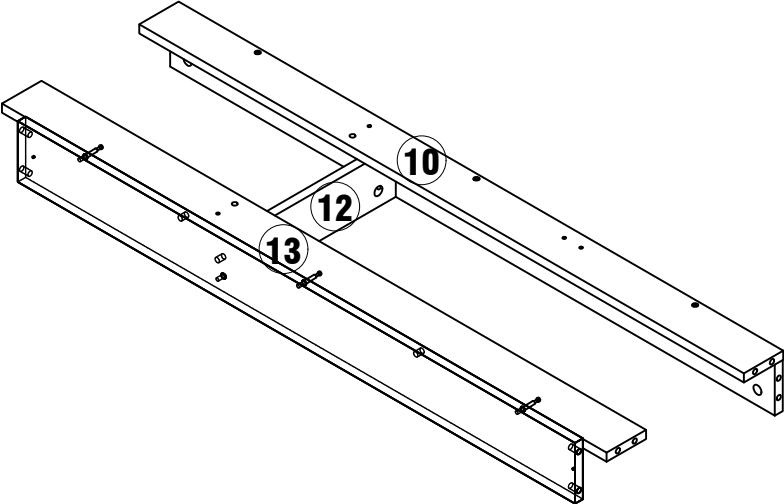
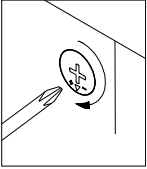
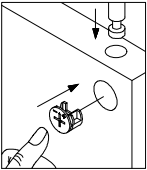
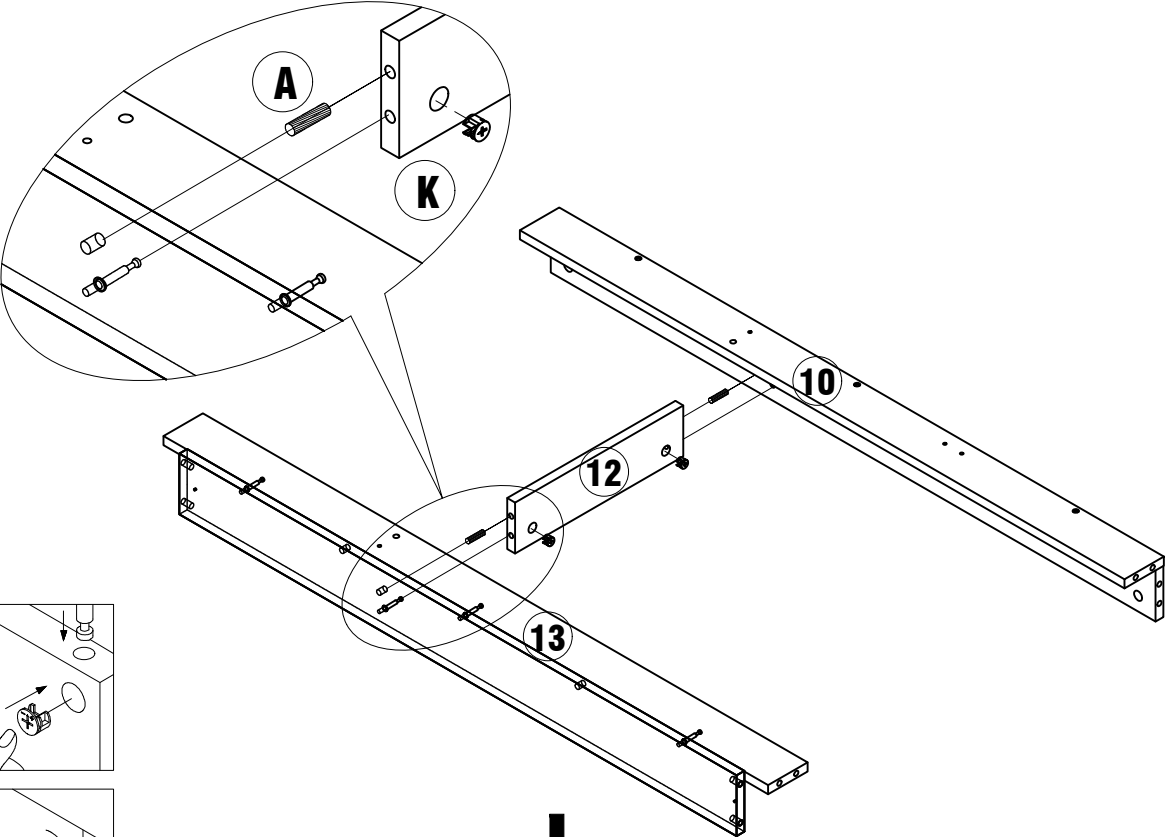

# STEP 5

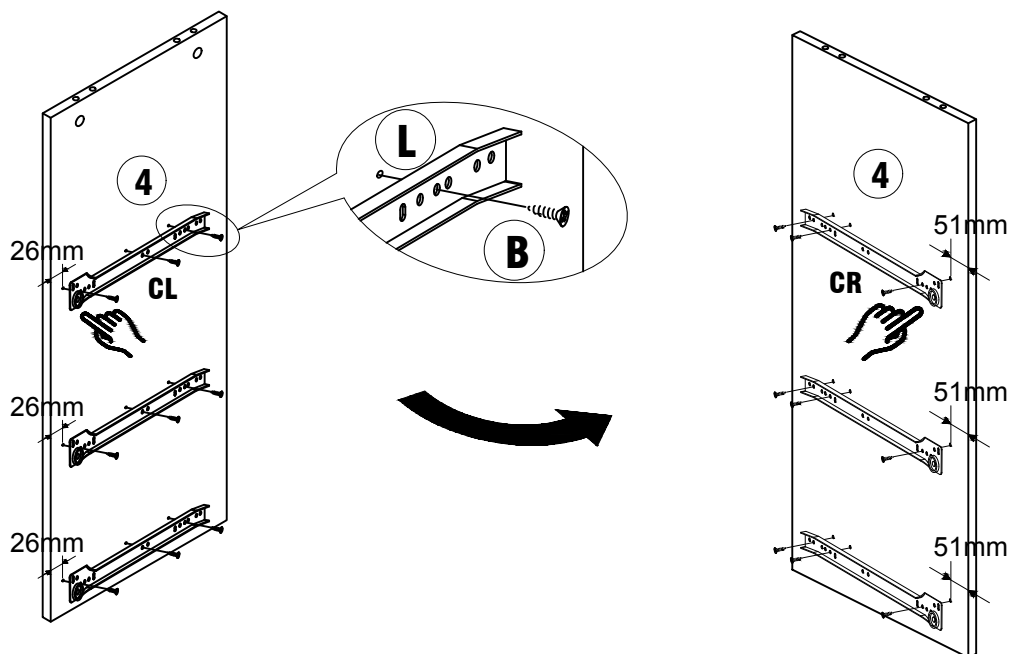
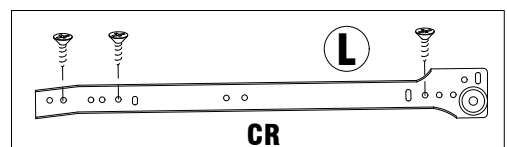
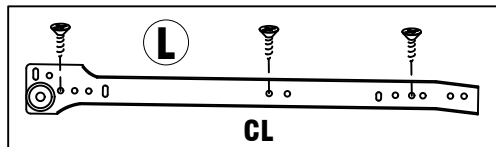
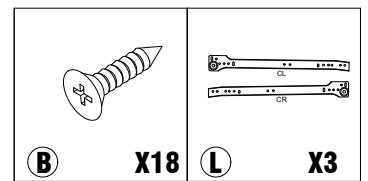

# STEP 6

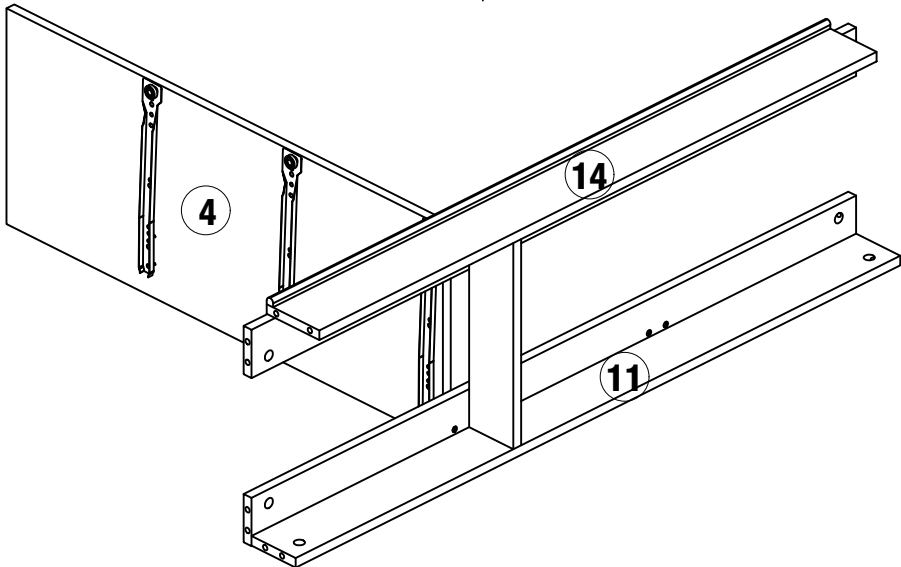
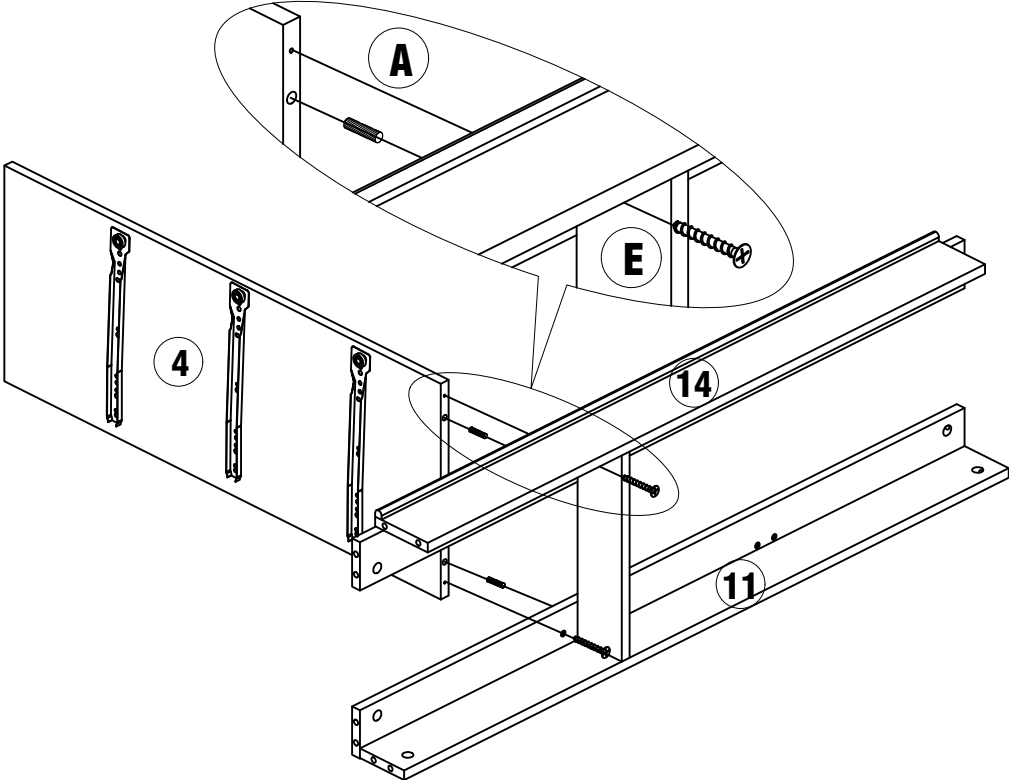
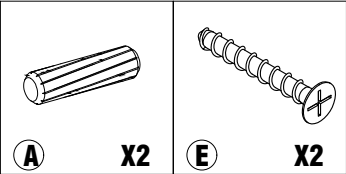

# STEP 7

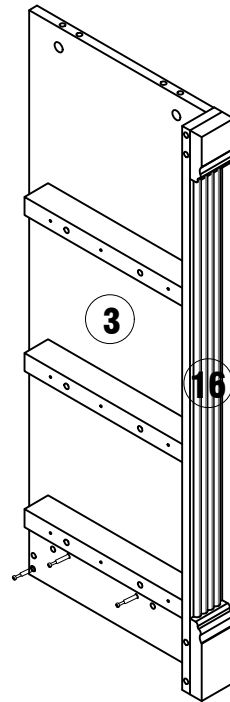
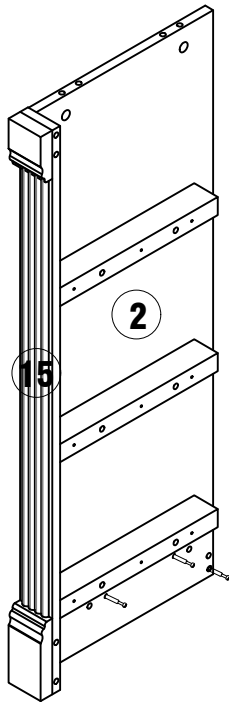
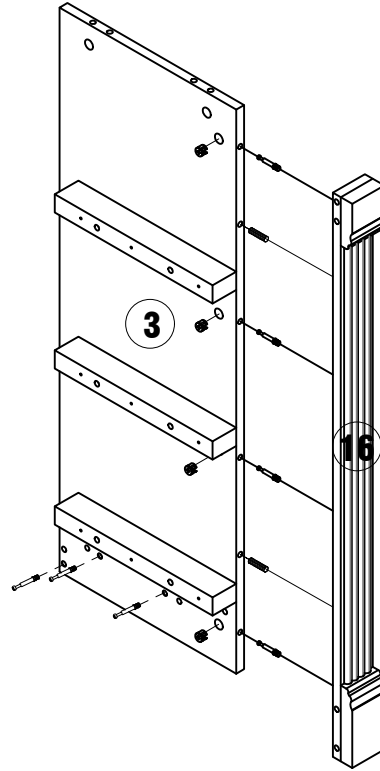
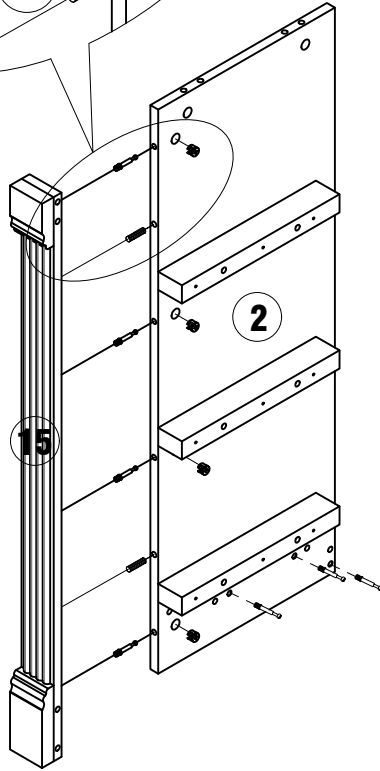
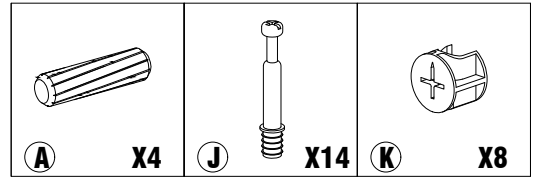
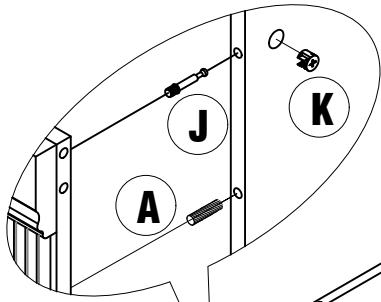
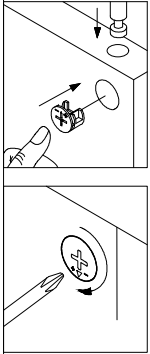

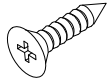
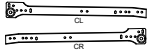

# STEP 8

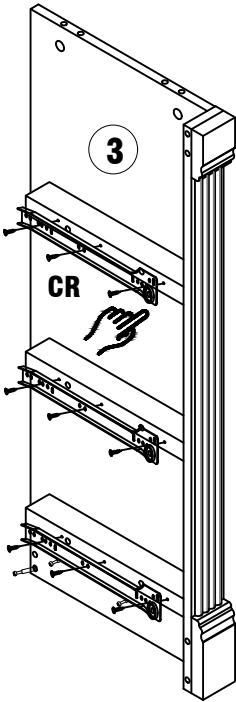
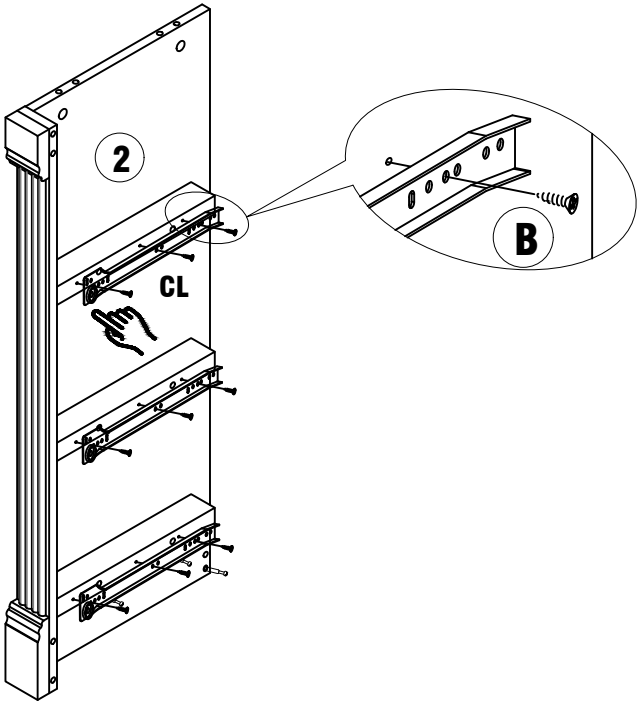
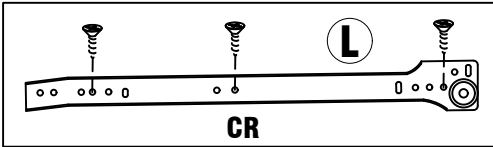
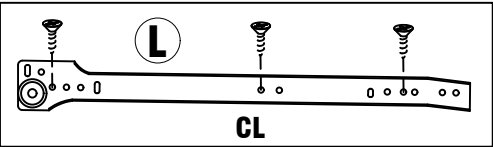
|   |   |
|---|---|
|  |  |
| <b>B</b>  | <b>X18</b>  |
| <b>L</b>  | <b>X3</b>   |



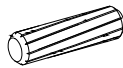
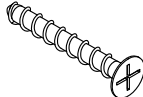

# STEP 9

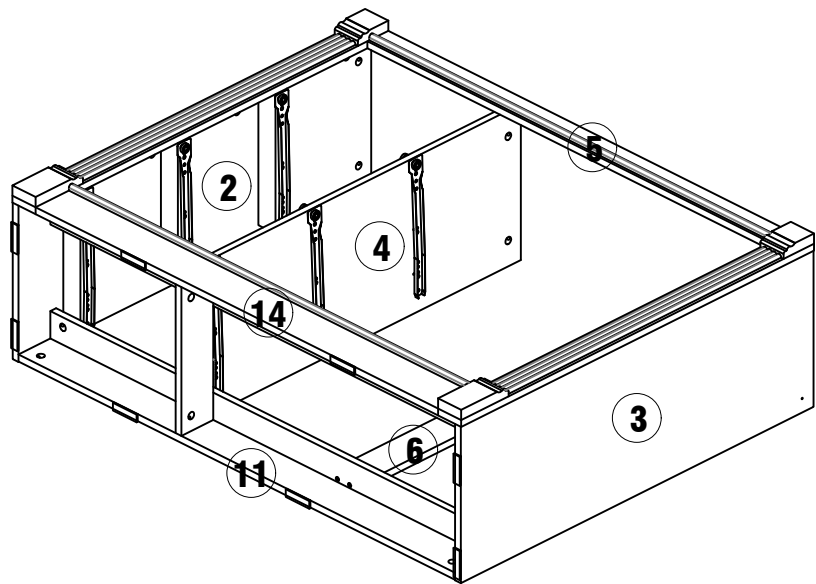
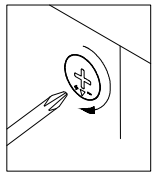
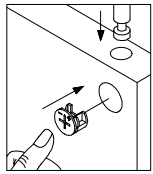
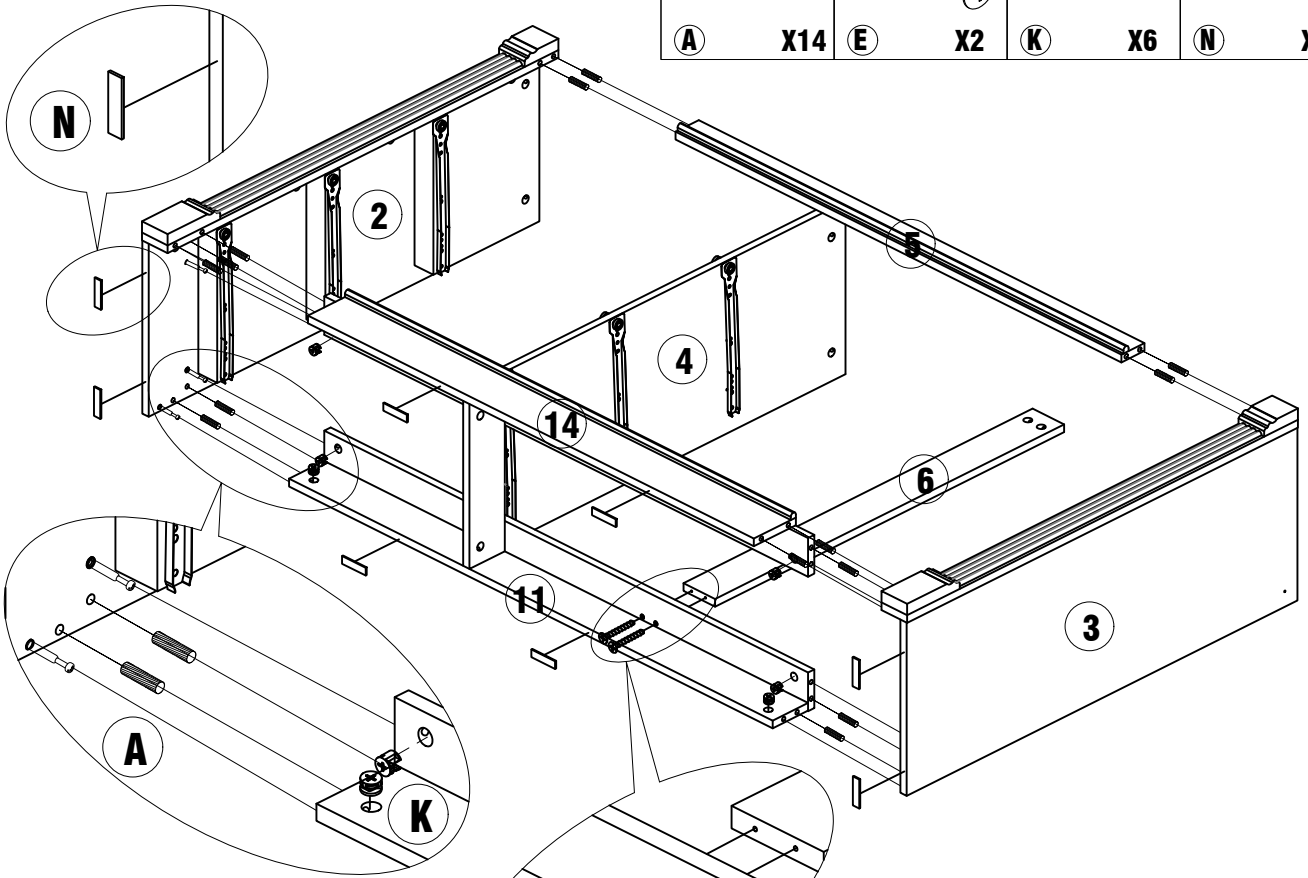
|   |   |   |   |          |           |          |           |
|---|---|---|---|----------|-----------|----------|-----------|
|  |  |  |  |          |           |          |           |
| <b>A</b>  | <b>X14</b>  | <b>E</b>  | <b>X2</b>   | <b>K</b> | <b>X6</b> | <b>N</b> | <b>X8</b> |

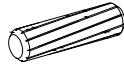

# STEP 10

|   |   |
|---|---|
|  |  |
| <b>A</b>  | <b>X8</b>   |
|   | <b>K</b>  |
|   | <b>X11</b>  |

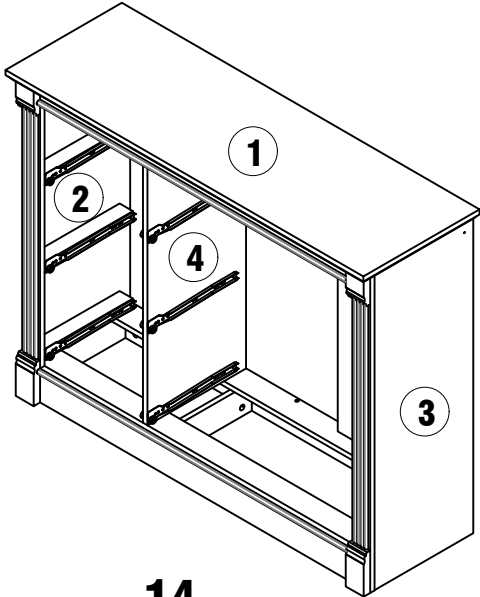
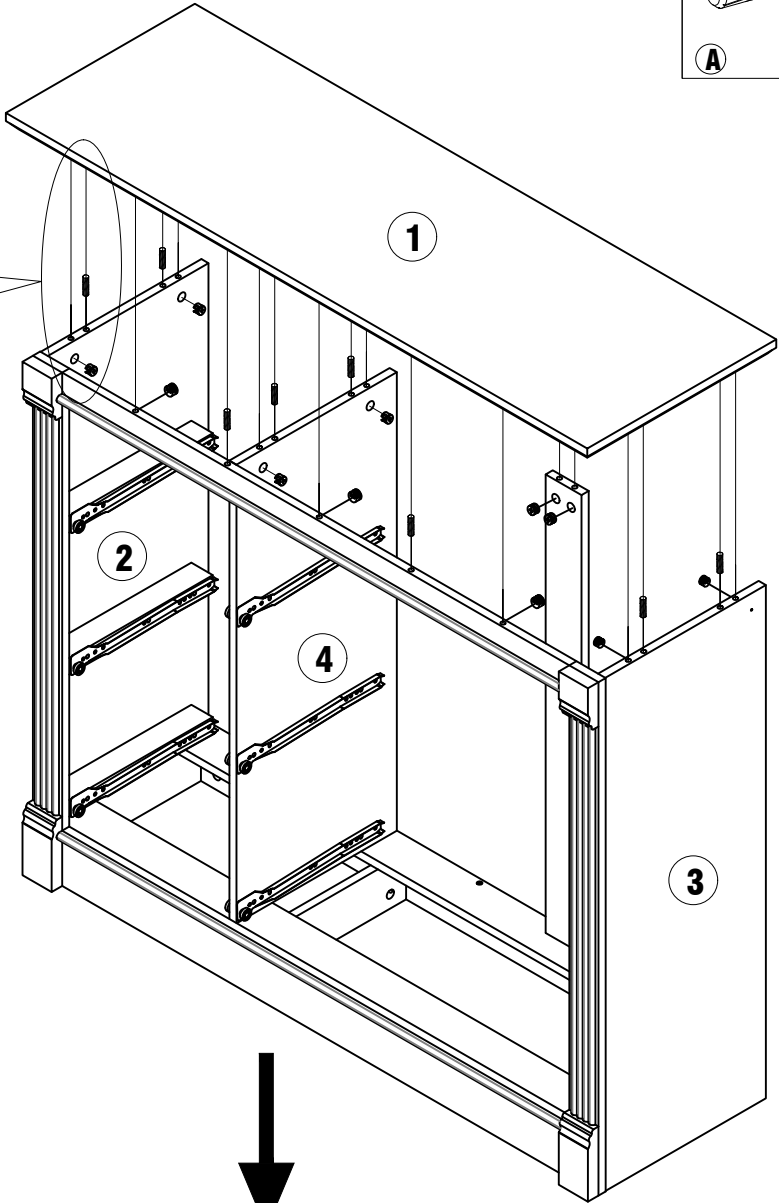
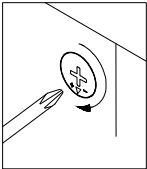
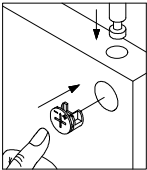
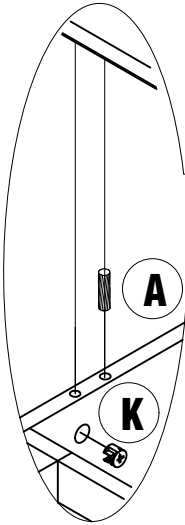

# STEP 11

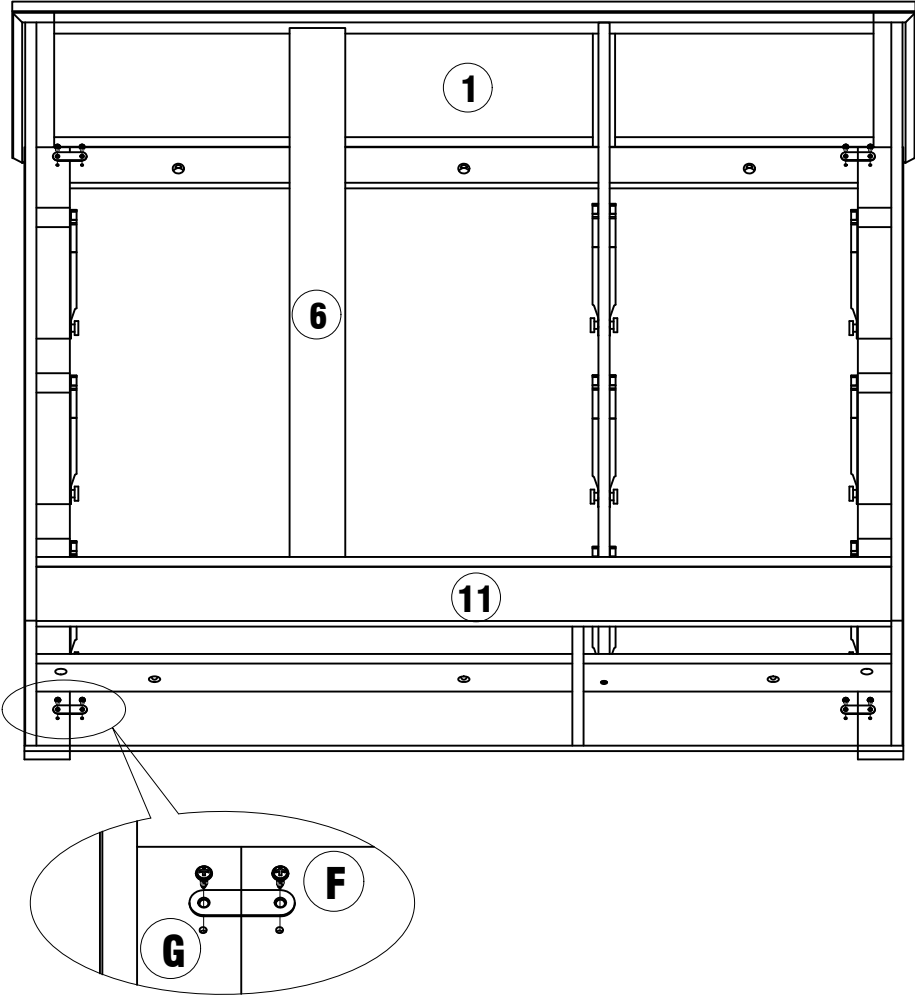
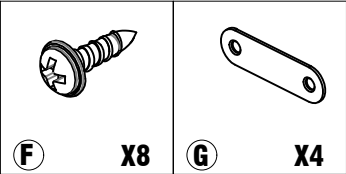

# STEP 12

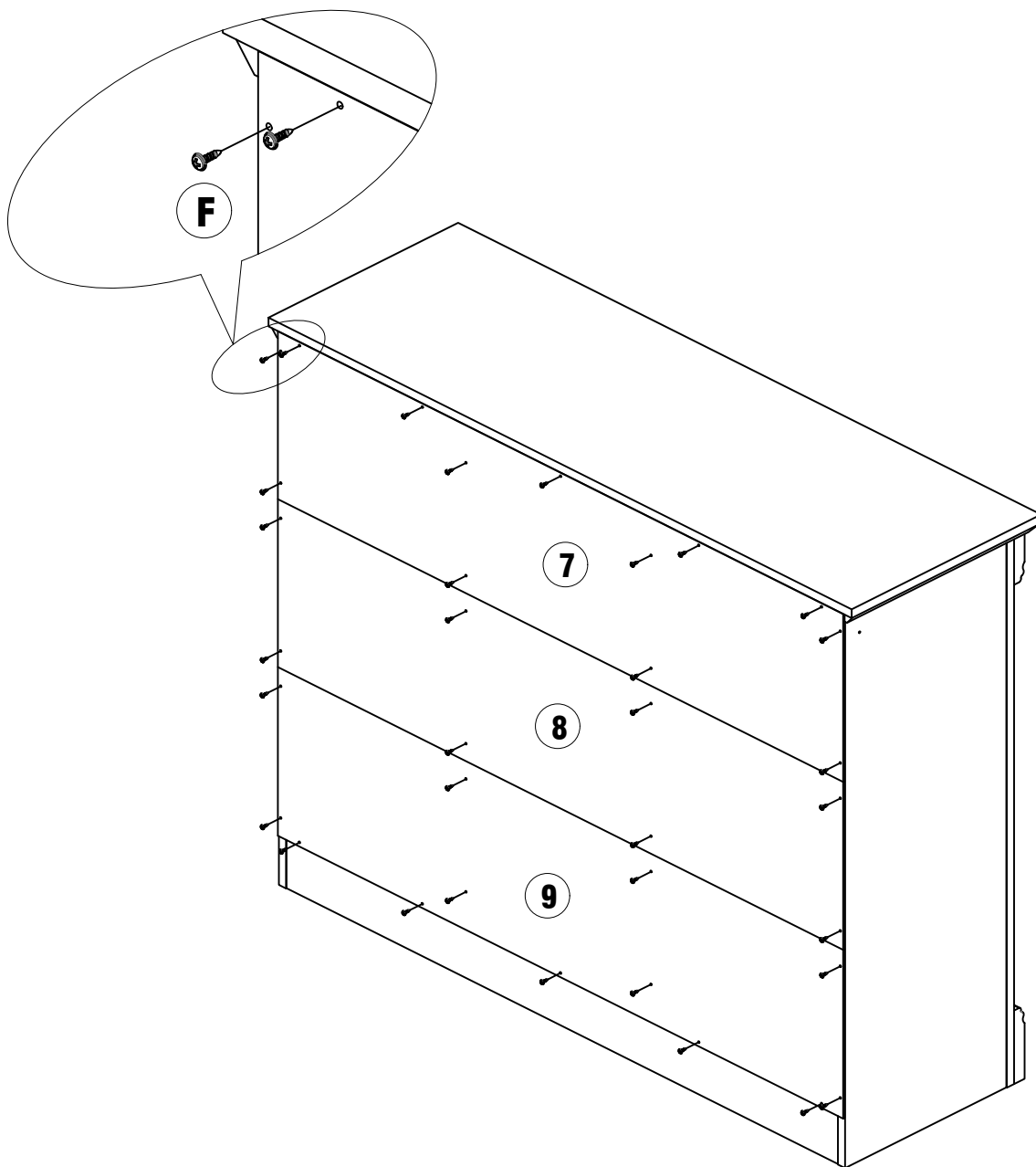
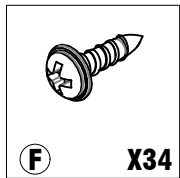

# STEP 13

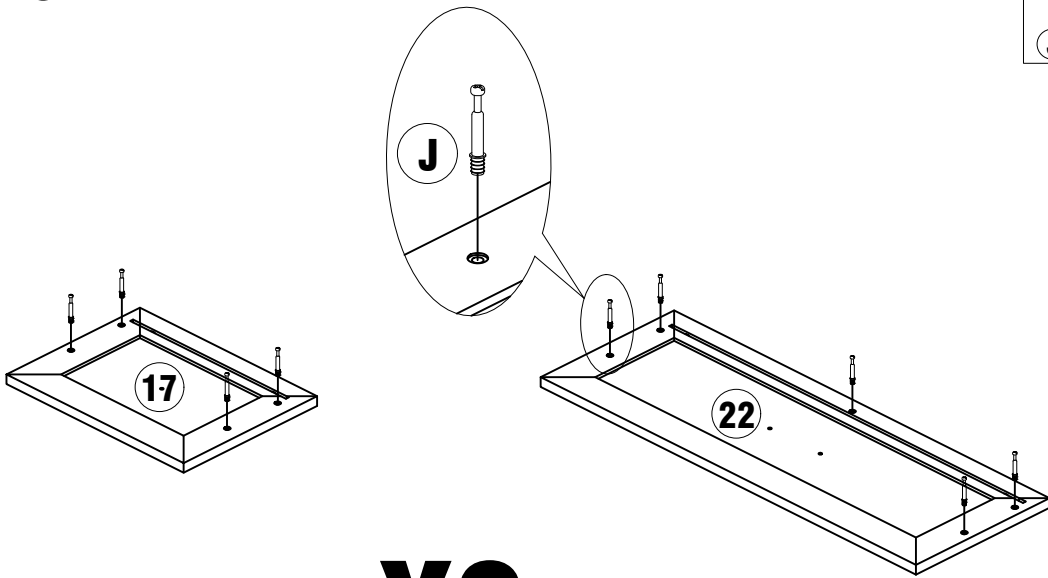
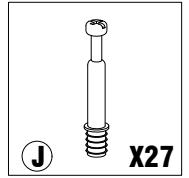

# X3

# STEP 14

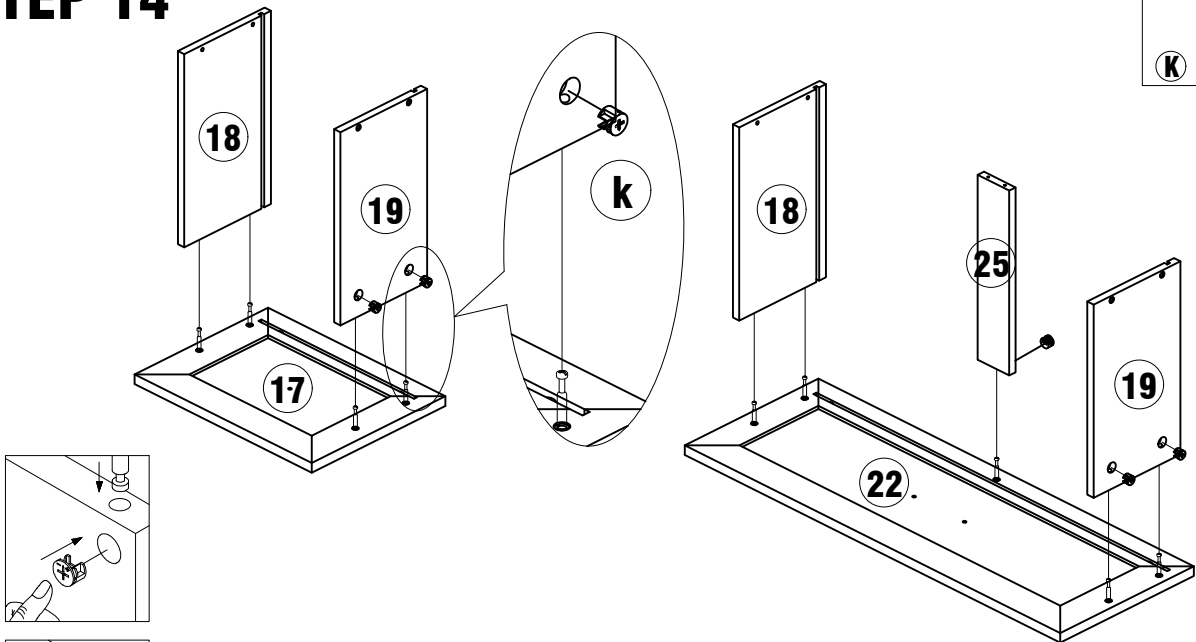
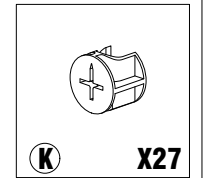

# X3

# STEP 15

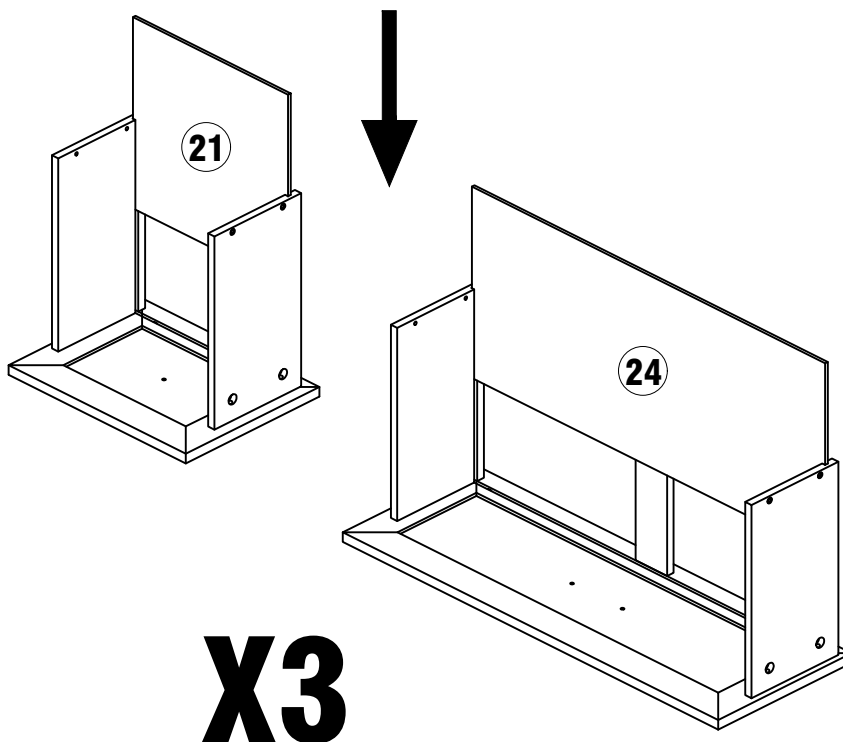

# STEP 16

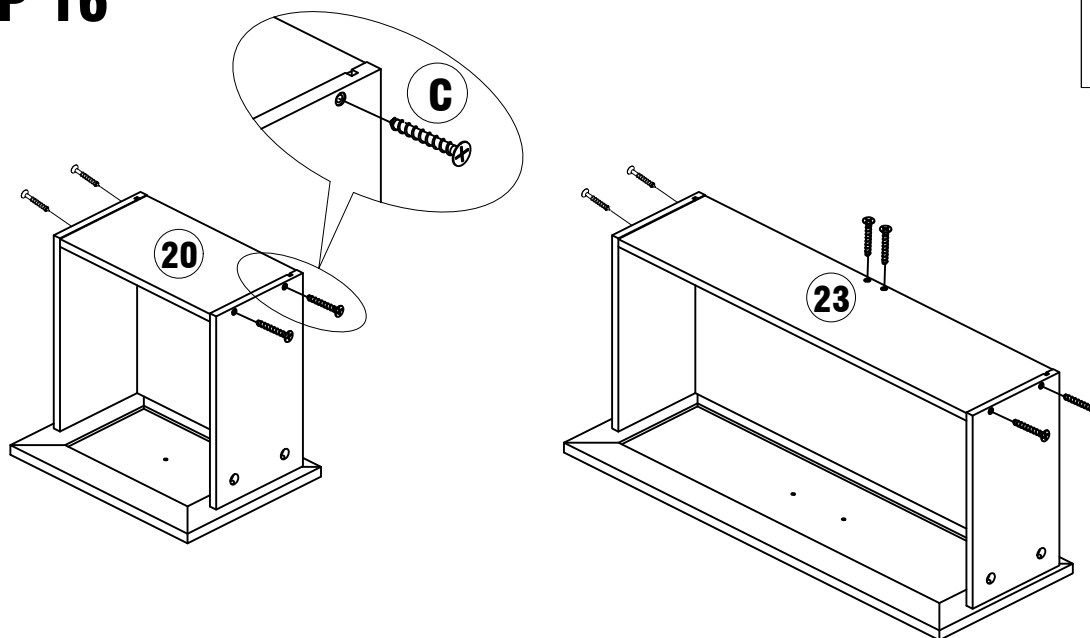

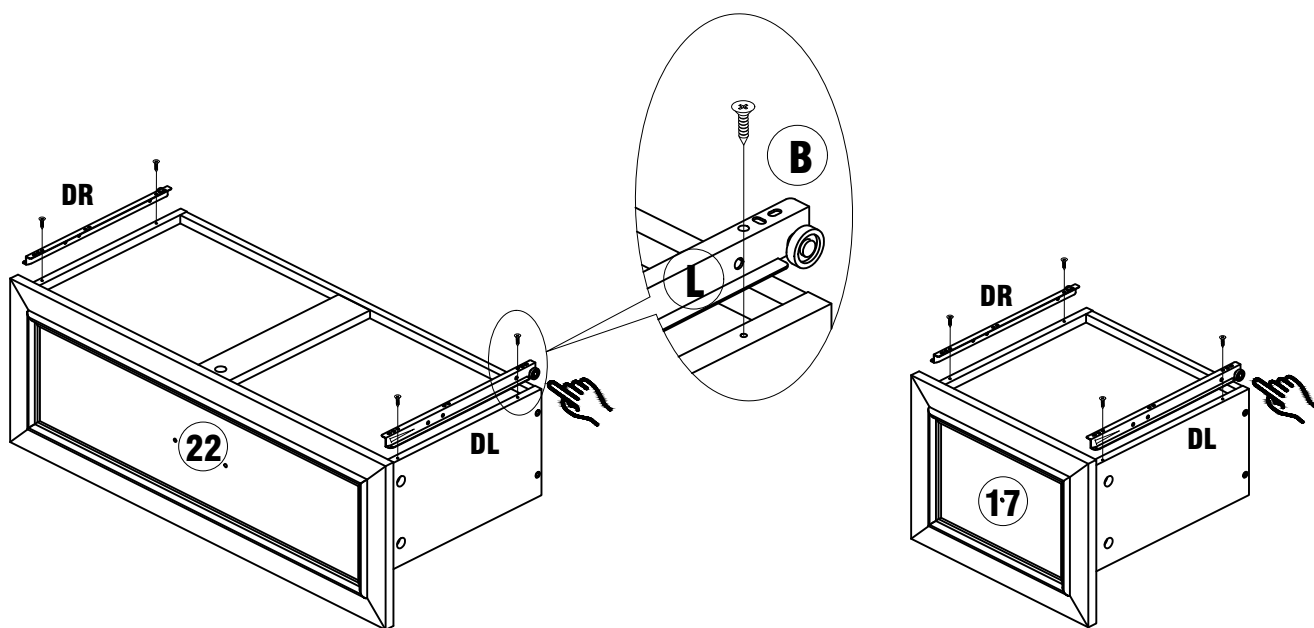
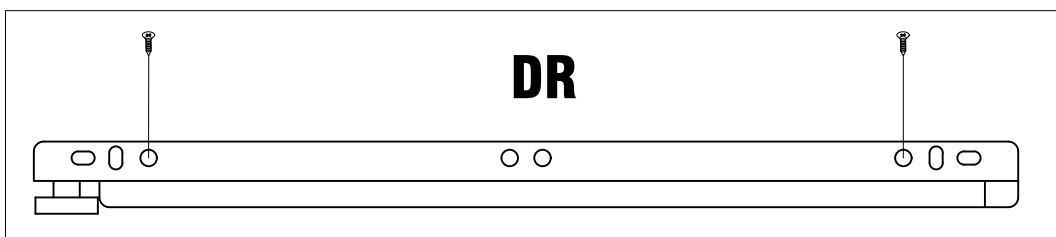
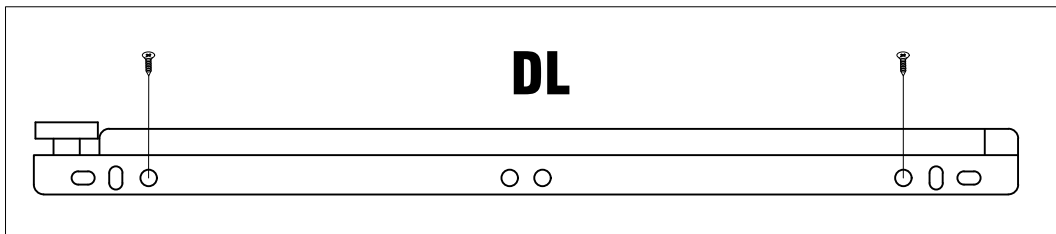
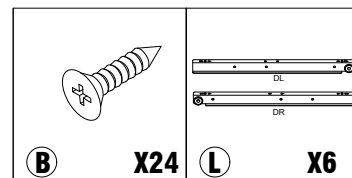

# STEP 17



# X3

# STEP 18

|   |   |
|---|---|
|  |  |
| <b>D</b>  | <b>X3</b>   |
|   | <b>M</b>  |
|   | <b>X3</b>   |

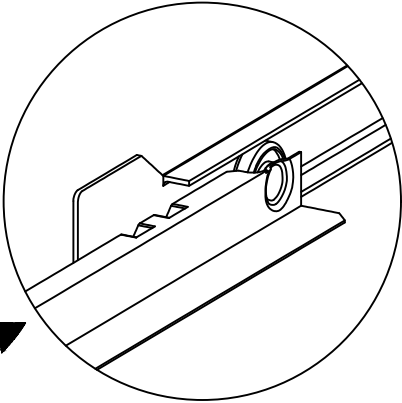
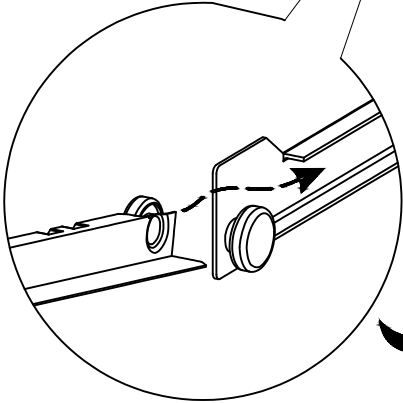
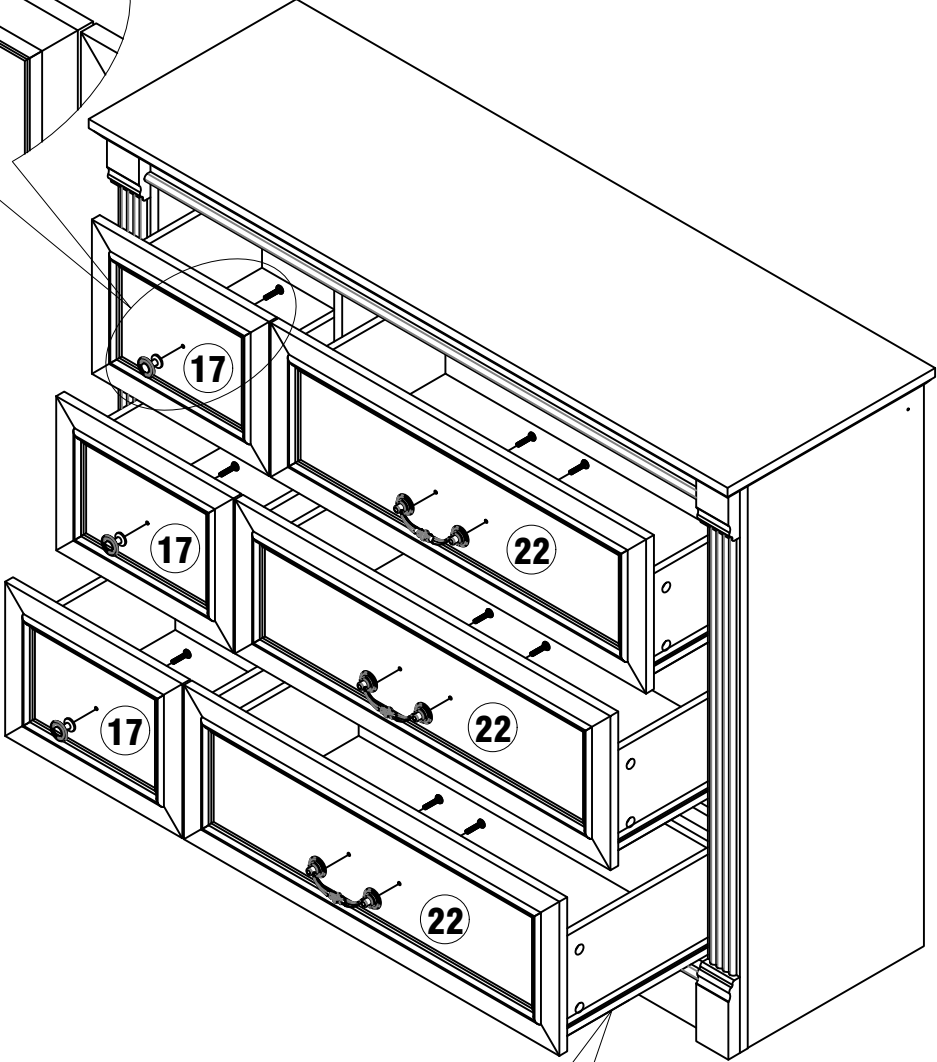
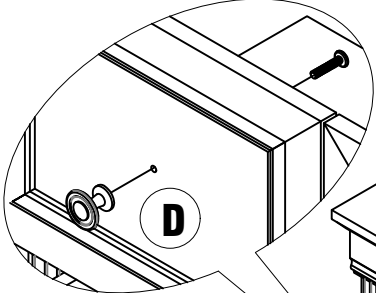

# STEP 19

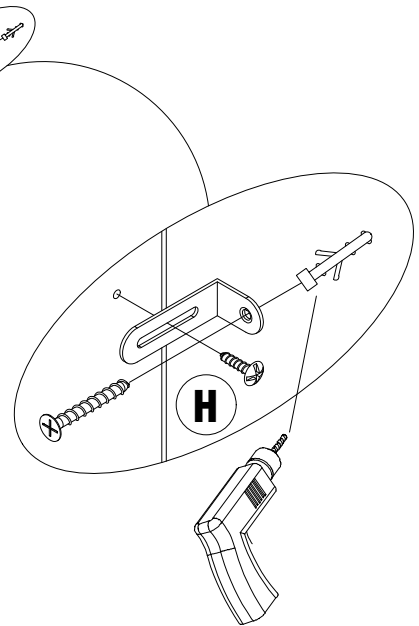
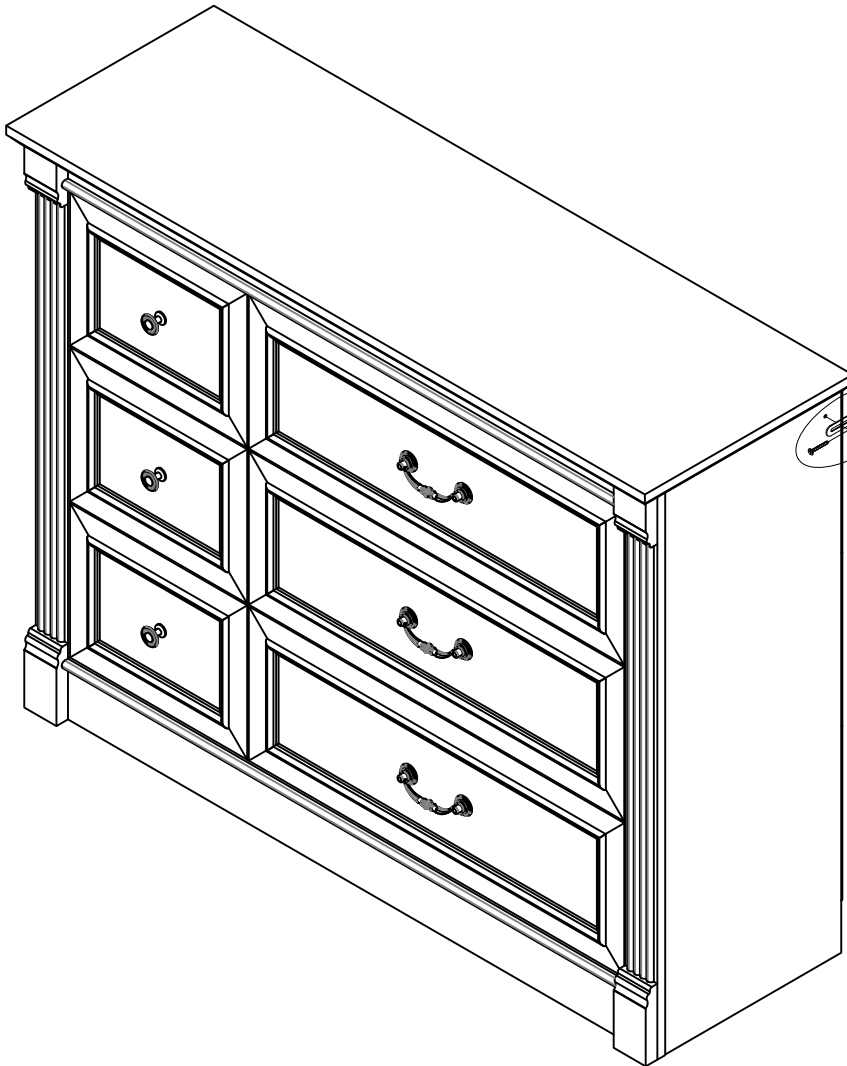
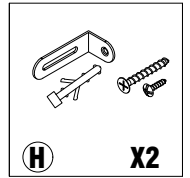

## ⚠ WARNING



**Children have died from furniture tipover. To reduce the risk of furniture tipover:**

- ALWAYS install anti-tip device provided.
- NEVER put a TV on this product.
- NEVER allow children to stand, climb or hang on any drawers, doors, or shelves.
- NEVER open more than one drawer at a time.
- Place heaviest items in the lowest drawers.

*this is a permanent label.  
Do not remove!*