

FABRIC TASK CHAIR

MODEL RTA-M101

ASSEMBLY INSTRUCTIONS

REV.GLDP-1-8106-0524

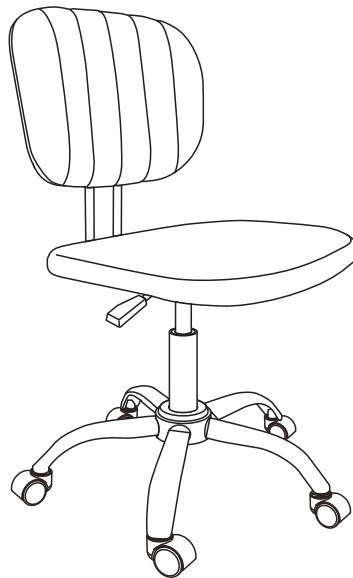







Thank you for purchasing our product

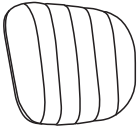

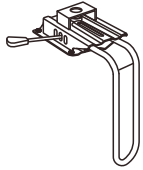

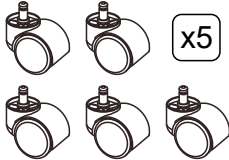
<p>Do a quick inventory of all the parts and hardware listed below.</p> 	<p>For Support, assembly questions & Replacement Parts within the 48 Contiguous United States:</p> <p>Please email us at: support@rtaproducts.com</p> 	<p>Replacement Parts for International Customers & AK-HI-PR orders: RTA Products will replace the part free of charge, while the customer is responsible for shipping costs plus any International local taxes or duties.</p>
---	---	--

MAIN PARTS LIST

<p>A Backrest</p> 	<p>B Seat</p> 	<p>C 5-Leg star base</p> 	<p>D Mechanism with support</p> 
<p>E Lift cylinder</p> 	<p>F Casters</p> 	<p>G Cover for base</p> 	

HARDWARE LIST

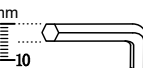

Part #	QTY	SIZE/Description	Item
1	2	M6x30	 mm 10 20 30 40 50
2	4	M6x16	 mm 10 20 30 40 50
3	4	Ø8, Ø17, 1mm	 mm 10 20 30 40 50
	1	M5 Allen wrench	 mm 10

If you will use your own power driver:

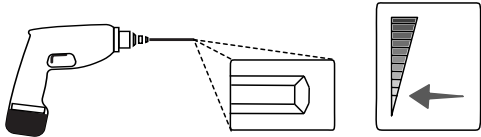
- Make sure to have on hand the appropriate bit and size.
- Start using at a low power or speed to avoid stripping the screws.

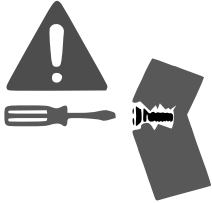

IMPORTANT NOTES

- Do not discard this manual or any of the packaging material until the unit is completely assembled. 
- Read the assembly instructions thoroughly and follow them step by step. 

- Do not overtighten or force the screws as they might break, strip, damage the threads of the holes, or get stuck inside the parts. 

ASSEMBLY STEPS

STEP 1

FIRST: Attach F to C using pressure

THEN

LAST

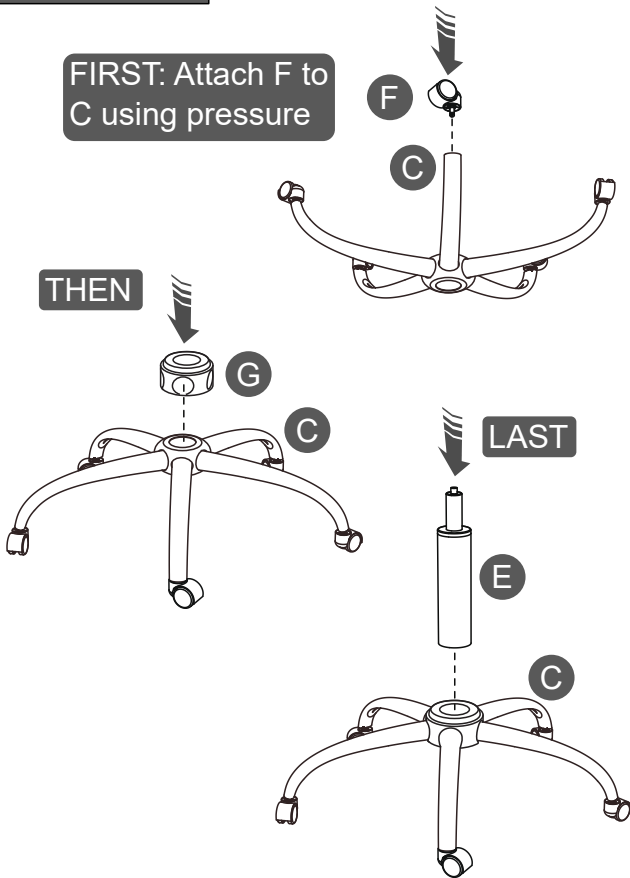

STEP 2

Assemble the mechanism D to the seat B with screws #2 and washers #3.

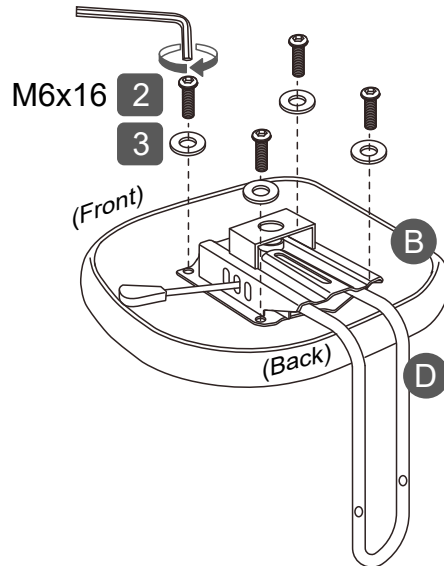

STEP 3

Assemble the backrest A to the support of the mechanism D with screws #1.

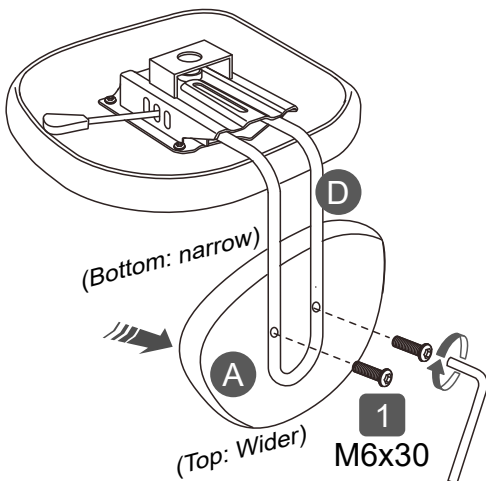

STEP 4

Join the seat to the base making sure the tip of the piston E enters correctly into the hole of the mechanism D.

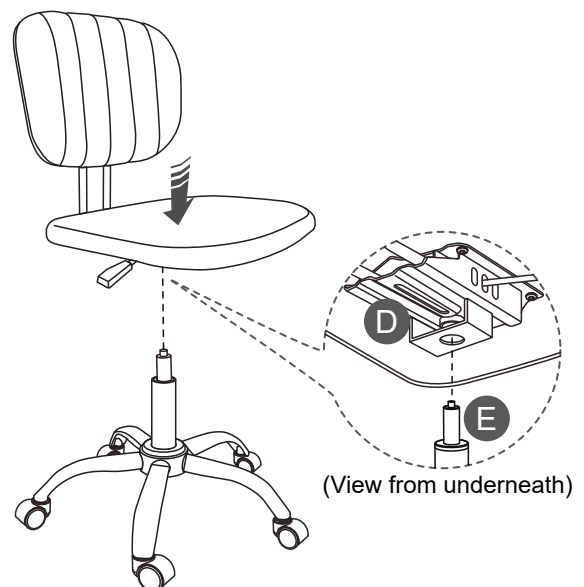

To raise or lower the chair's height, pull UP the lever that is under the seat on the right side. The chair goes down while sitting on it, or up if you lift your body.

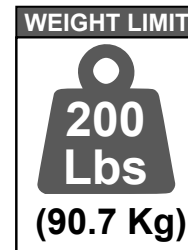
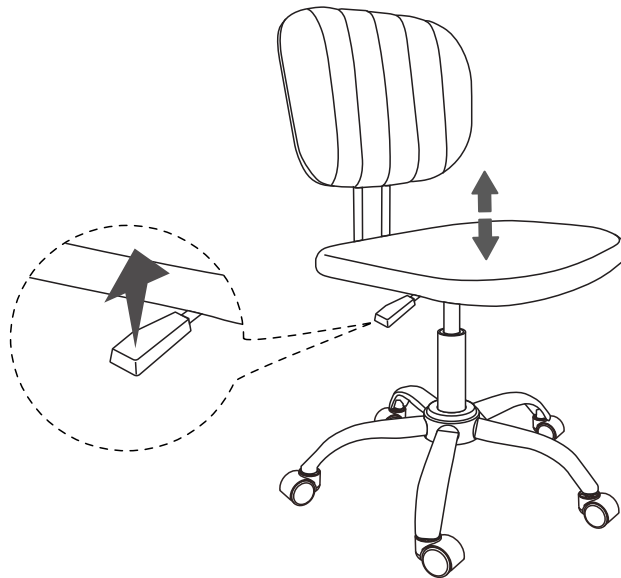

Do not exceed Max. weight limit as indicated above.

WARNINGS

Not paying attention to the following warnings could result in injuries.

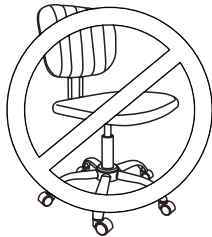

Do not use the chair if the frame parts are damaged, or if any of the screws are loose or missing.

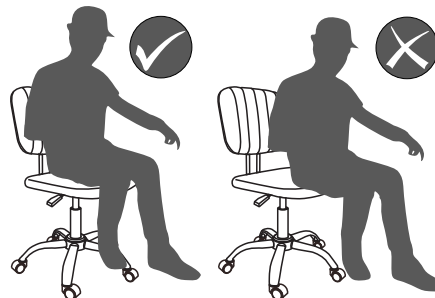

Only one person at a time and refrain from sitting on the edge of the seat to prevent the chair from tipping over.



Do not leave babies or toddlers unattended while seated on the chair, always ensure adult supervision. Keep children from playing with the chair for their safety.

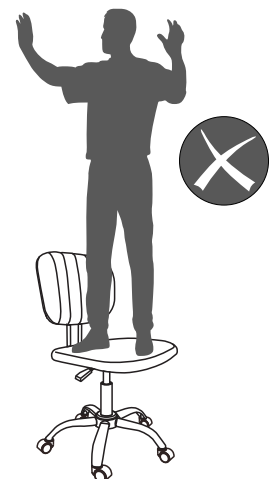

Do not stand or use the chair as ladder.

CARE AND MAINTENANCE

- To clean the chair it is recommended to use a soft cloth lightly damped in a solution of smooth soap and water, then dry with a clean towel.
- Do not use solvents or abrasive materials to clean any part of the chair.
- Before using a cleaning agent, test on a small hidden area of the chair, like underneath the seat.
- Do not expose the product to direct sunlight or to extreme environmental conditions.
- Inspect the chair completely every 4 months and make sure that all screws are tightened.

TECHNI MOBILI WARRANTY**TASK/KID'S CHAIR: 1-YEAR WARRANTY**

RTA Products, LLC has warranted the Techni Mobili office chairs to the original purchaser who acquired a new product from RTA Products or its authorized resellers of the product against defects in material or workmanship.

This warranty is expressly limited to the repair or replacement (at its option) of defective chair components or materials that fails under normal use as a result of a defect in materials or workmanship. This warranty is limited to merchandise purchased in the Continental United States, excludes AK, HI and PR. No assembly labor is included. The word "defects" as used in this warranty, is defined as imperfections that impair the utility of the product.

This warranty applies under conditions of normal use, but does not apply to defects that result from intentional damage, negligence, unreasonable use or exposure.

Liability for consequential damages is excluded to the extent exclusion is permitted by law. This warranty gives you specific legal rights, and you may have other rights that vary from State to State.

RTA Products does not warrant: a) natural variations in character marks b) changes in surface finishes due to aging or exposure to light c) marks, scars, or wrinkles occurring naturally in leather d) failure resulting from normal wear and tear e) the matching of colors, grains, or textures of natural materials f) the colorfastness or the matching of textiles, including an exact match to cuttings or to swatch cards g) damage, marking, or staining of veneer surfaces due to contact with rubber or similar compounds, damage from sharp objects or imprinting from writing instruments, or prolonged exposure to direct sunlight h) we do not warrant products that are exposed to extreme environmental conditions or that have been subject to improper storage.

RTA Products shall not be liable for loss of time, inconvenience, commercial loss, or incidental or consequential damages.

Any modification to the original product voids the warranty. We do not warrant the performance of the product when used in combination with other than original products.

This product has been designed for and is intended for office and home-office use only. This warranty is Original Purchaser's sole remedy for product defects, and this warranty does not extend to any product, or damage to any product, caused by or attributed to abuse or misuse, products used for commercial or rental purposes, use modifications of, or attachments to the product, and products or parts not used, maintained, or extended hereunder is in lieu of any and all other warranties, express or implied, including without limitations any implied warranty or merchantability or of fitness for a particular purpose.

To file a Claim within the 48 contiguous United States: Email us to warranty@rtaproducts.com to explain the defect and provide your name, address, phone number, model number of our product, date and place, and proof of purchase. Please provide pictures of the damage or defect.

If we determine that a replacement will remedy the situation, and in order to determine the extent or the cause of the defect, purchaser may be requested to send the part in question at purchaser's expense. Once we receive the part, we will examine it and determine whether the claim is valid (or not), and then proceed to send the replacement. We will ship the replacement at our expense.

Replacement Parts for International Customers & AK-HI-PR orders: RTA Products will replace the part free of charge, while the customer is responsible for shipping costs plus any International local taxes or duties.