

Café™ 48" Dual-Fuel Commercial-Style Range with 6 Burners and Griddle (Natural Gas)

C2Y486P2TS1 / C2Y486P3TD1 / C2Y486P4TW2

CAFÉ

DISTINCT BY DESIGN™



ALSO AVAILABLE IN

C2Y486P2TS1
Stainless Steel with Brushed Stainless handle and knobs

C2Y486P3TD1
Matte Black with Brushed Stainless handle and knobs



FEATURES & BENEFITS

Versatile Cooktop - The versatile cooktop on this commercial-style range features an entire arsenal of burners that give you the right amount of heat and control to perfectly cook anything from delicate sauces to expertly seared meats.

Caterer Oven - A large capacity oven fits a full-size catering pan and has three racks, large 8-pass bake and broil elements for even heat coverage and Precision Oven modes to help guarantee results for meals of any size.

Second oven for everyday use - A second everyday oven gives you the space and features you need for family meals, including enough room for two 9" x 13" casserole dishes, two self-clean racks, no-preheat air fry, convection cooking, a precision temperature probe and more.

Color-Matched Manifold with LCD Control - Get a coordinated look with a manifold that matches the range's finish and an LCD control panel that provides information like oven and probe temperatures and cooking time for perfect cooking results.

Superior Heat Distribution - The industry-exclusive Inspiral burner swirls the cooktop flame under cookware to more evenly spread heat from the center to the edges.

Multi-Ring Burner - A versatile burner offers different-sized flame rings on a single burner element, so it's like having multiple burners in one.

Built-in Griddle with Thermostat - An 18,000-BTU, Stainless Steel and Aluminum clad griddle features an integrated thermostat, which automatically adjusts heat to hold your set temperature.

Two Griddle Burners - Cook more at once with two 12,000-BTU powerful burners that can be used together or separately with an optional griddle grill accessory.

Two High-Heat Burners - Boil water quickly with two 18,000-BTU Power Boil burners that give you more cooking power.

WiFi ENABLED FEATURES

Built-in WiFi - This smart oven features WiFi connection so you can control oven functions with the SmarthQ app on your smart device.

No-Preheat Air Fry - Cook healthier, crispier versions of your favorite foods in less time, thanks to an air fryer right in your oven that doesn't require preheating, a basket or a special tray.

FEATURES

Configuration	Double Oven Range
Cooking Technology	Convection
Oven Cleaning Type	Self-Clean with Steam Clean Option (Both Ovens)
Burner - Left Front	21,000 BTU
Burner - Left Rear	18,000 BTU
Burner - Right Front	10,000 BTU
Burner - Right Rear	18,000 BTU
Burner - Center	12,000 BTU Front / 12,000 BTU Rear
Griddle	18-000-BTU (NG) and 16,000-BTU (LP)
Cooktop Burner Type	Sealed
Cooktop Surface	Porcelain-Enamel Gray
Dishwasher Safe Knobs	Yes
Control Location	Front controls
Control Type	Digital Temperature Display with Timer Display Knob (Both Ovens)
Valves (Degree of Turn)	270
WiFi Enabled Features	Remote Oven Control Remote Notifications Clock Sync Scan-to-Cook Voice Control Precision Cooking Modes No Preheat Air Fry Meat Probe (App-Based func) Clock Set
Connected Integrations	Amazon Alexa DiGiorno Drop IFTTT Innit Sonos The Google Assistant
Range Control Features	Audible Preheat Signal Auto Oven Shut-Off Auto Self Clean Electronic Timer Front Controls In-Oven Broiling Self-Clean Cool Down Time Display Temperature Probe
Oven Cooking Modes	Convection Bake Multi/Single Rack (Both Ovens) Convection Broil Hi/Lo (Both Ovens) Convection Roast (Both Ovens) Proof (Both Ovens) Warming (Both Ovens)
Oven Features	8-Pass Broil Element
Cooktop Burner Grate Features	Continuous Grates Heavy-Cast Edge-to-Edge Grates
Cooktop Burner Grate Material	Heavy Cast
Cleaning Time	Variable with Delay Clean Option
Self-Clean Oven Door Lock	Automatic
Oven Rack Features	1 Self-Clean Extension Rack (Caterer Oven) 1 Self-Clean Extension Rack (Everyday Oven) 1 Self-Clean Flat Rack (Everyday Oven) 2 Self-Clean Flat Oven Racks (Caterer Oven) 4 Rack Positions (Everyday Oven) 5 Rack Positions (Caterer Oven)
Fuel Type	240V Electric and Natural Gas
Ignition System	Electronic w/Auto Reignition
Leveling System	4 Leveling Legs
Style	Commercial
Lower Oven Features	Dual element broil Hidden bake
Cooking System	True Convection with Reverse Air

CAPACITY

Total Capacity (cubic feet)	8.25 cu ft
Capacity (Cu. Ft.)	5.75 Caterer Oven / 2.5 Everyday Oven

Café™ 48" Dual-Fuel Commercial-Style Range with 6 Burners and Griddle (Natural Gas)

C2Y486P2TS1 / C2Y486P3TD1 / C2Y486P4TW2

CAFÉ

DISTINCT BY DESIGN™

ACCESSORIES

LP Conversion Kit	Included High Altitude Natural Gas: WB28X39728 High Altitude LP: WB28X39729
Griddle	18,000-BTU (NG) and 16,000-BTU (LP) Stainless Steel and Aluminum Clad Included
Backsplash	UX12BS48PSS, 12" backsplash UXADBS48PSS, 30"-36" adjustable-height backsplash with warming shelf

WEIGHTS & DIMENSIONS

Cabinet Opening	30 in
Depth with Door Open	43 7/8 in
Approximate Shipping Weight	672 lb
Net Weight	576 lb
Overall Height	35 1/4 in
Height to Cooking Surface (in.)	35 1/4 to 36 3/4
Overall Width	47 7/8 in
Cabinet Width	48 in
Overall Depth	28-1/4
Interior Dimensions - Companion Oven (WxHxD) (in.)	12-1/4 x 16-3/8 x 21-3/8
Interior Dimensions - Main Oven (WxHxD) (in.)	24 x 14 x 20-3/8

APPEARANCE

Color Appearance	Matte White
Cooktop Burner Grate Color	Matte Black
Oven Door Features	Big Clear View Oven Window
Handle Color	Brushed Bronze
Handle Design	Café Consumer Removable
Control Knobs	Consumer Removable Dishwasher Safe Commercial-Style Stainless Steel

POWER / RATINGS

Bake/Broil Wattage - Main Oven	2700/4000W
Top Burner BTU Rating - LP (000's BTU's)	(1) 18.0; (2) 15.0; (2) 12.0; (1) 9.1
Top Burner BTU Rating - Nat. Gas (000's BTU's)	(1) 21.0; (2) 18.0; (2) 12.0; (1) 10.0
Volts/Hertz/Amps	240V; 50A
Power Connection	Power Cord - Included
Convection Wattage	2500W

WARRANTY

Parts warranty	Limited 1-year entire appliance
Labor warranty	Limited 1-year entire appliance
Warranty notes	See written warranty for full details

DIMENSIONS AND INSTALLATION

Electrical Requirements: Ranges must be hooked up to a 208/240V, 60Hz properly grounded dedicated circuit protected by a 50-amp circuit breaker or time-delay fuse.

Gas Pressure Regulator: You must use the gas pressure regulator supplied with this range. For proper operations the inlet pressure to the regulator should be as follows:

Natural Gas:

Minimum pressure: 6" of Water Column

Maximum pressure: 13" of Water Column

Propane (LP) Gas:

Minimum pressure: 11" of Water Column

Maximum pressure: 13" of Water Column

See installation instructions for more details

Optional Backsplash Accessories: The range requires a 12" minimum clearance to a vertical combustible surface at the rear. A backsplash is required for installations with less than 12" clearance. The following backsplash accessories are available, or a custom, non-combustible backsplash can be used.

Order one with a 48"-wide range backsplash

UX12BS48PSS – 12" backsplash

UXADBS48PSS – 30"-36" adjustable-height backsplash with warming shelf

NOTE: Commercial-style ranges offer a number of choices in size and cooktop configurations. All commercial-style ranges are factory set for natural gas.

Conversion kits are included with the range. High Altitude Kit, High Altitude Natural Gas: WB28X39728; High Altitude LP: WB28X39729 are also available. The kits must be installed by a qualified service technician at additional cost.

Installation Information: Before installing, consult installation instructions packed with product or online at geappliances.com for current dimensional data. A suitable 48" or wider vent hood is required for installation over ranges with a grill and recommended for all other ranges.

Advance Planning: Refer to dimensional drawings for appropriate placement and necessary clearances when planning the installation.

- Working areas adjacent to the range should have 18" minimum clearance between countertop and cabinet bottom.

- Clearance between range and side wall or combustible material must be at least 12" on each side.

- Installation must conform with local codes. In the absence of local codes, the range must comply with the National Fuel Gas Code, ANSI Z223.1-1990.

WARNING: Installations without a hood require 48" minimum to combustibles. A custom hood installation with exposed horizontal combustible surfaces must have an Auto-On feature. Refer to hood installation instructions for specific hood clearances.

The surface of the entire back wall above the range and below the hood must be covered with a non-combustible material such as metal, ceramic tile, brick, marble or other stone.

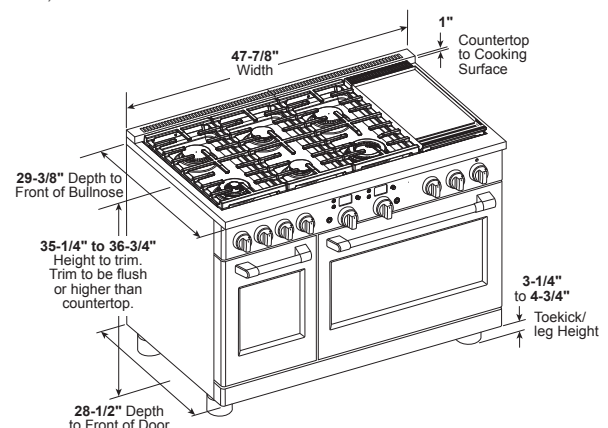

Café™ 48" Dual-Fuel Commercial-Style Range with 6 Burners and Griddle (Natural Gas)

C2Y486P2TS1 / C2Y486P3TD1 / C2Y486P4TW2

CAFÉ

DISTINCT BY DESIGN™

DIMENSIONS AND INSTALLATION

UTILITY LOCATIONS

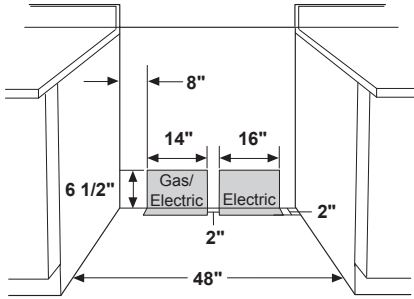

SIDE VIEW WITH BACKSLASH

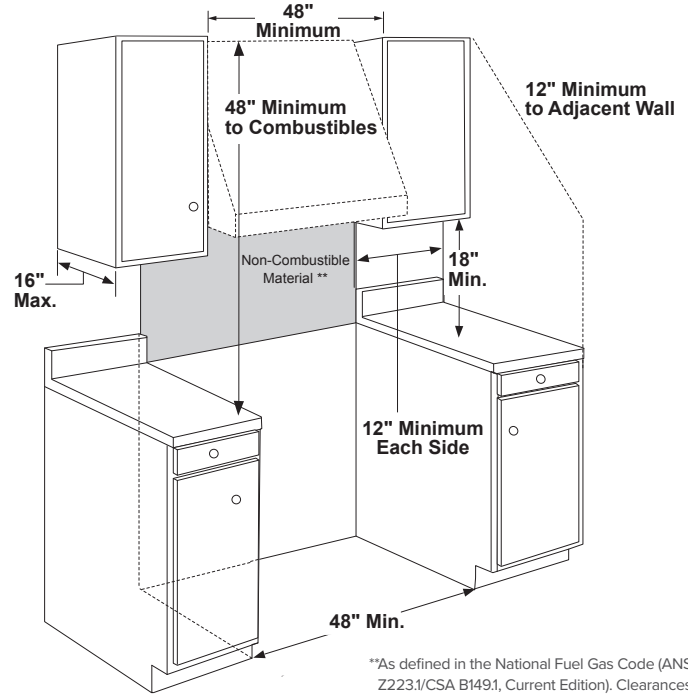
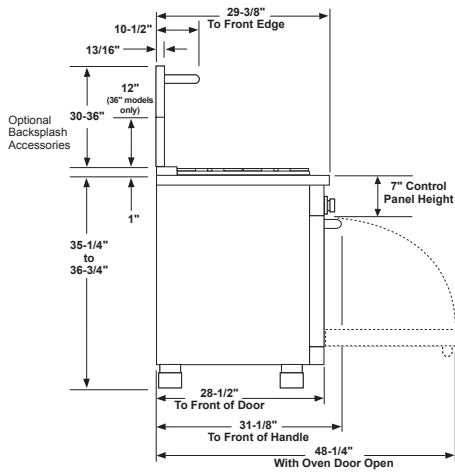

**As defined in the National Fuel Gas Code (ANSI Z223.1/CSA B149.1, Current Edition). Clearances from non-combustible materials are not part of the ANSI Z211/CSA 11 scope and are not certified by CSA. Clearances less than 12" must be approved by local codes and/or the authority having jurisdiction.

ADDITIONAL CLEARANCES

Allow 12" minimum clearance to an adjacent wall on each side. Working areas adjacent to the rangetop should have 18" minimum clearance between countertop and the bottom of the wall cabinet.

ADDITIONAL ACCESSORIES



CXPR8HKPMBZ
Brushed Bronze
2 handles; 9 knobs



CXPR8HKPMBT
Brushed Black
2 handles; 9 knobs



CXPR8HKPMC
Brushed Copper
2 handles; 9 knobs



CXPR8TKPMSS
Stainless Steel
Toe Kick Pro Range 48"



UXADBS48PSS
Stainless Steel
48" Backslash with shelf



WB15K10088
Griddle Cover Handle



WB01T10104
Griddle Handle Screw



WB07K10432
Griddle Cover



WB31K10223
Bamboo Cutting Board



UX12BS48PSS
12"H Stainless Steel
Backslash