

Assembly Guide

Assembly Guide

TOOLS REQUIRED









1 PERSON
ASSEMBLY



UP TO 45 MIN.
ASSEMBLY

HARDWARE

1 M6X10mm screw  40PCS	2 M6 wing nuts  38PCS	3 Allen key  1PCS
--	--	--

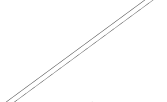
A Anteroposteri or plate  4PCS	B Lateral plate  2PCS	C glove  1copy	D Connecting rod  1PCS
--	--	---	--

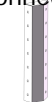
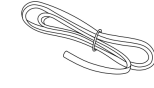
E Angle connector  4PCS	F Block gi ne  1copy
---	---

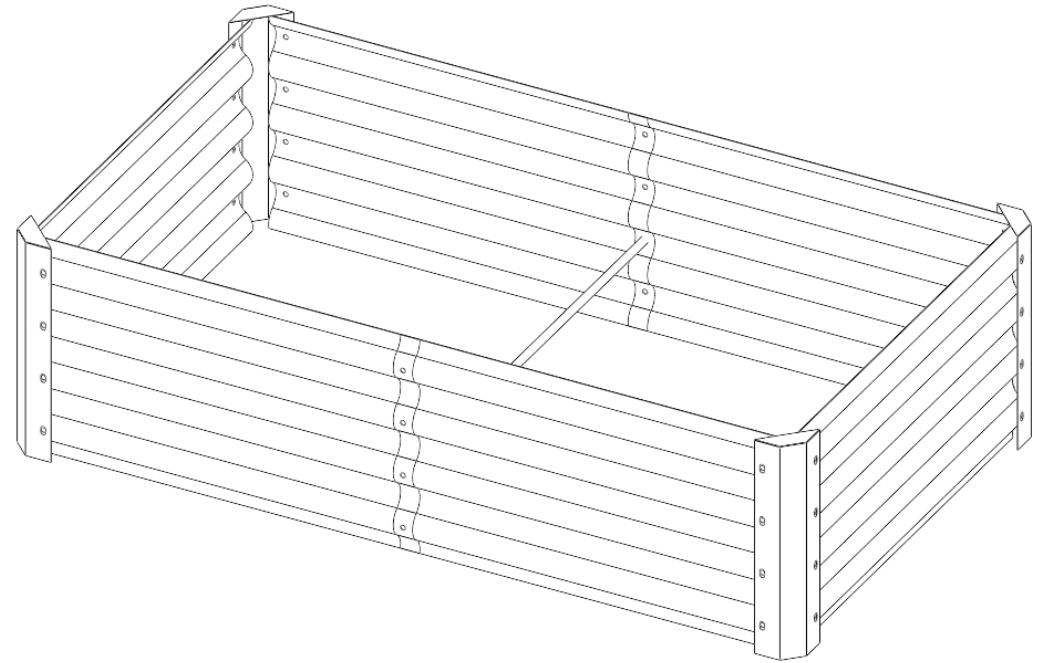

1000*600*280mm
1200*600*280mm

Assembly Guide

1. As shown in Figure 1, connect and fix panel A and panel B with the corner accessory E using screw 1 and nut 2

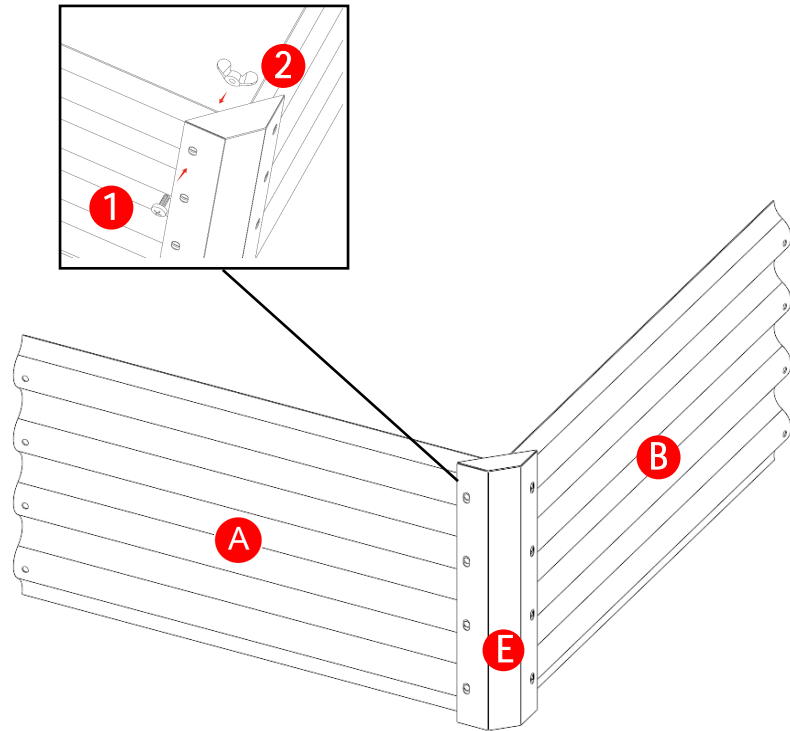

1

Assembly Guide

2. As shown in Figure 2, the panel B is connected and fixed to the corner accessory E with screw 1 and nut 2

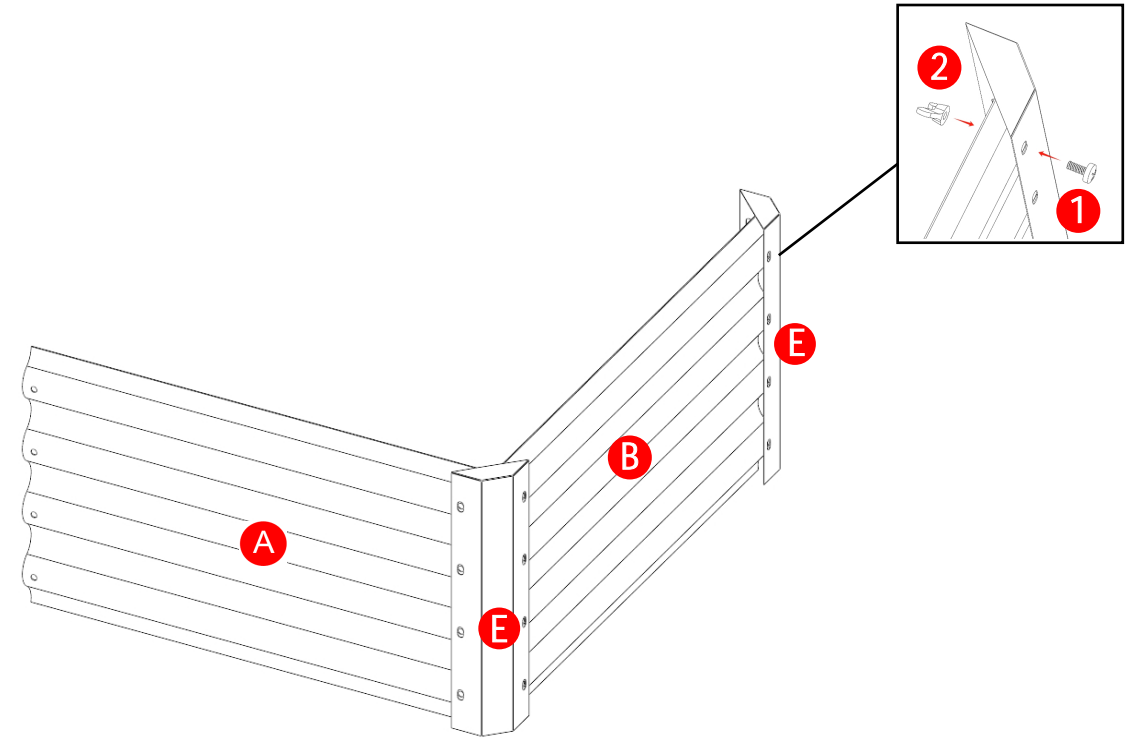

2

Assembly Guide

3. As shown in Figure 3, continue to connect and fix the panel A with the corner accessory E using screw one and nut two

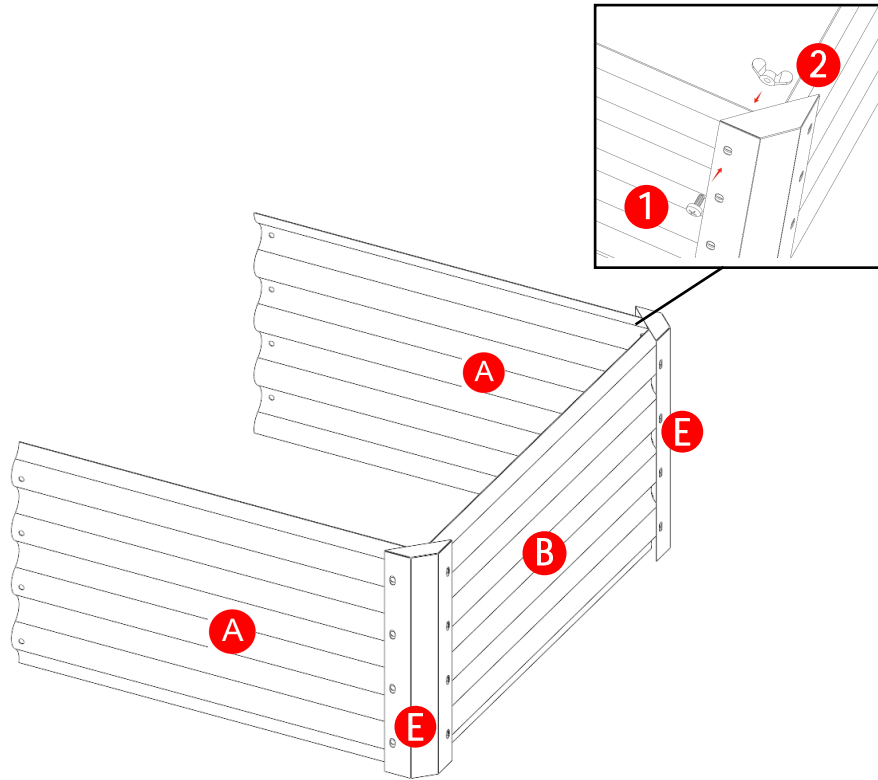

3

4. As shown in Figure 4, the front and rear panels A are connected and fixed to panel A with screw one and nut two

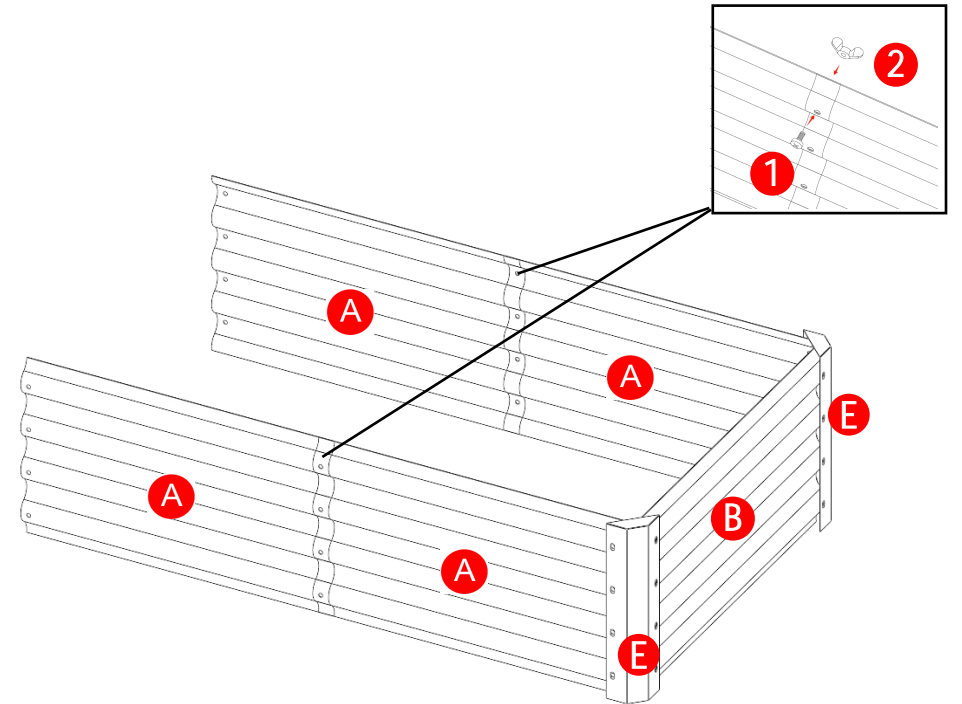

4

Assembly Guide

5. As shown in Figure 5, continue to connect and fix the panel A with the corner accessory E using screw 1 and nut 2

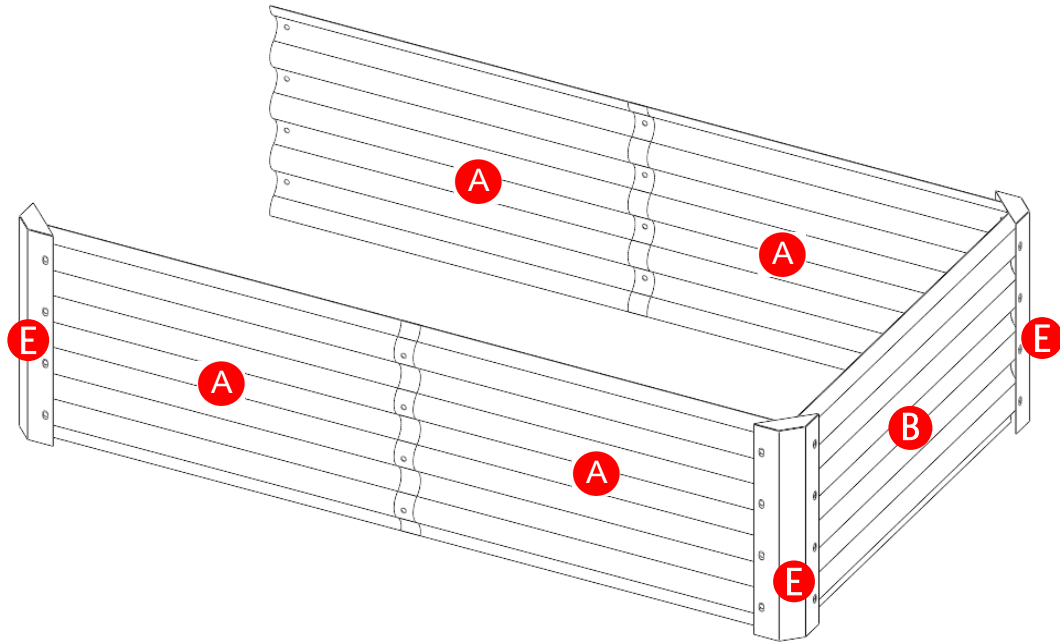

5

Assembly Guide

6. As shown in Figure 6, continue to connect and fix the panel B with the corner accessory E using screw 1 and nut 2

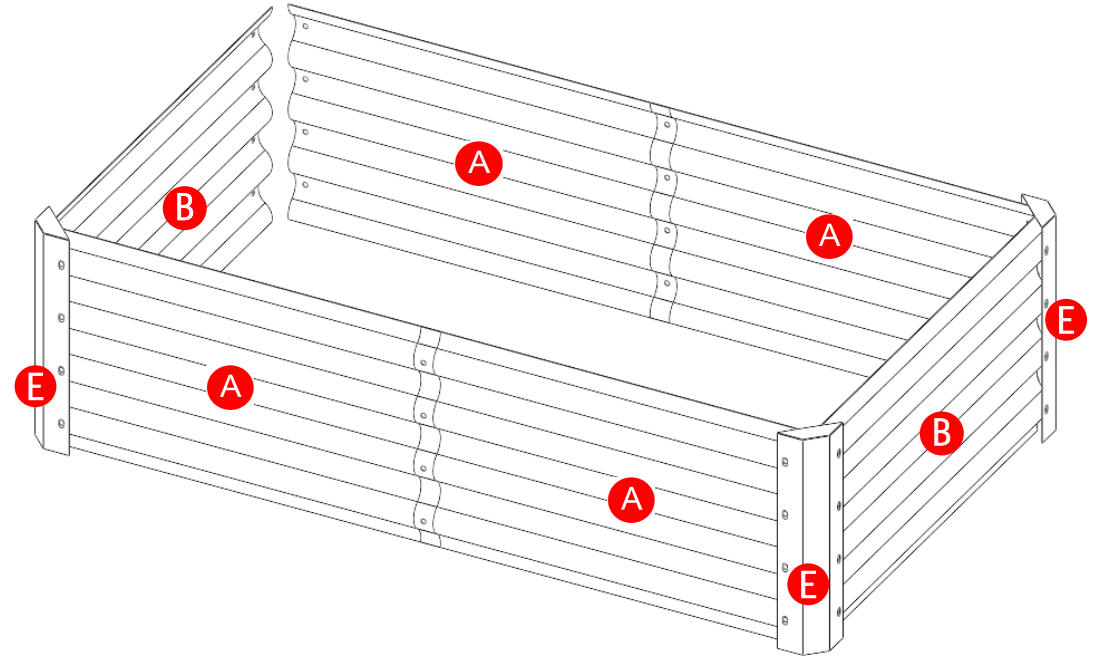

6

Assembly Guide

7. As shown in Figure 7, fix the corner accessory E to panel B and panel A with screw 1 and nut 2

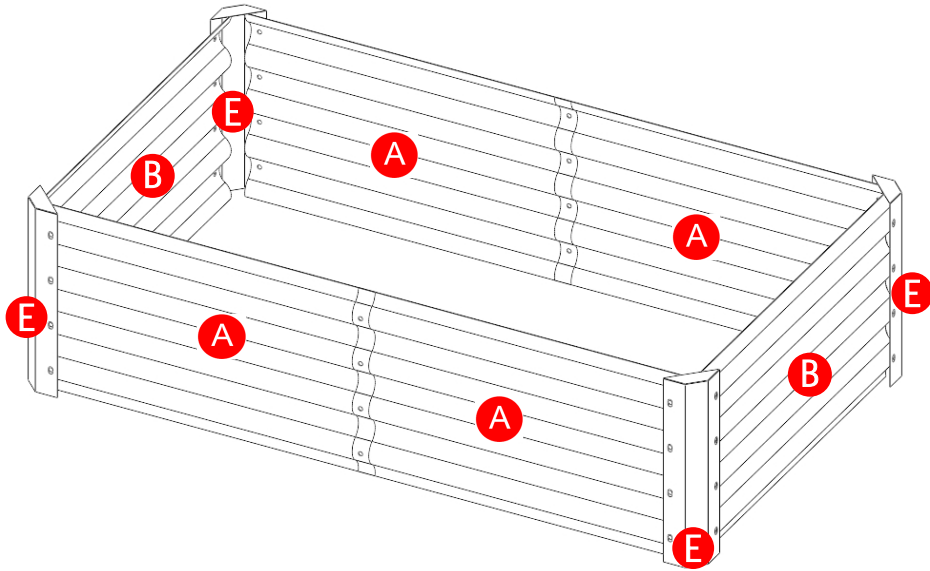

7

Assembly Guide

8. As shown in Figure 8, the support rod D is fixed to the front and rear panels A with screw one

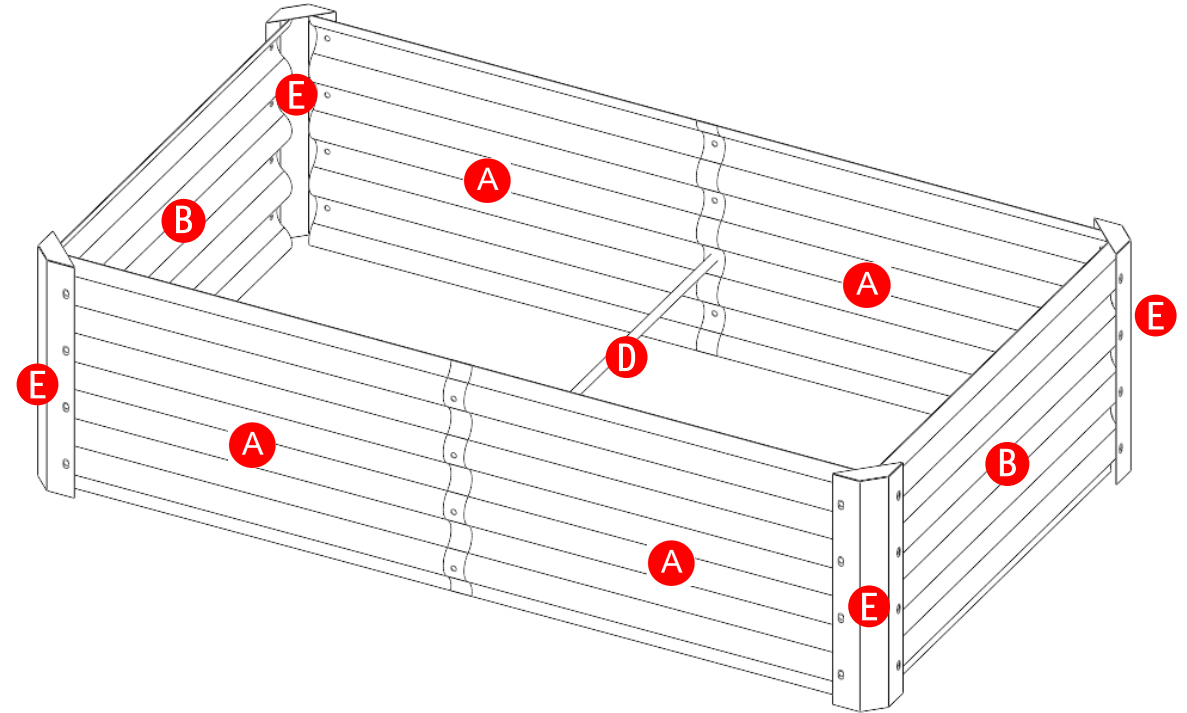

8

Assembly Guide

9. Tie the rubber strip (F) to the top of the flower bed panel and cut off the excess part according to the length of each side panel.

