

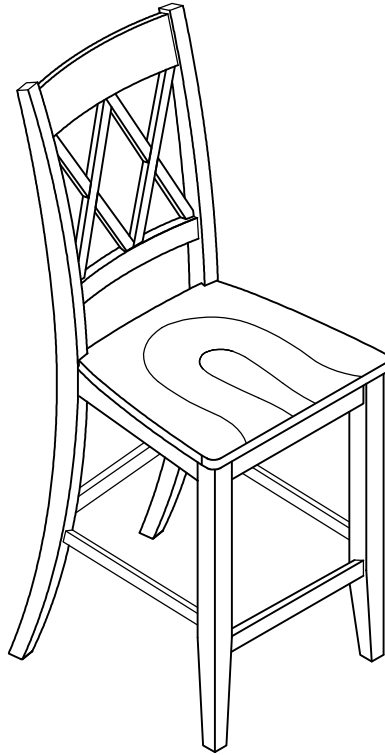









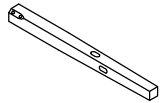

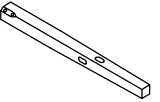

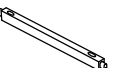
# ASSEMBLY INSTRUCTIONS

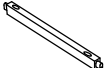
## IMPORTANT NOTE :

- \*\* PLACE ALL PARTS ON A CLEAN AND SMOOTH SURFACE SUCH AS A RUG OR CARPET TO AVOID THE PARTS FROM BEING SCRATCHED.
- \*\* BEFORE YOU BEGIN, KINDLY FOLLOW THE ASSEMBLY INSTRUCTIONS STEP BY STEP.
- \*\*DO NOT TIGHTEN ALL SCREWS AND BOLTS UNTIL THE CHAIR IS FULLY SET-UP.



CARTONS ONLY ONE/ CARTONS SEULEMENT UN

PART LISTS				HARDWARE LISTS			
NO.	DESCRIPTION	SKETCH	Q'TY	NO.	DESCRIPTION	SKETCH	Q'TY
1	FRONT LEG - L		4 PCS	A	BOLT Ø1/4" x 38mmL		8 PCS
2	FRONT LEG - R		4 PCS	B	BOLT Ø1/4" x 60mmL		16 PCS
3	LEFT STRECHER		4 PCS	C	BOLT Ø1/4" x 75mmL		16 PCS
4	RIGHT STRECHER		4 PCS	D	SPRING WASHER Ø1/4" x 13mmL		40 PCS
5	FRONT STRECHER		4 PCS	E	FLAT WASHER Ø1/4" x 19mmL		40 PCS
6	SEAT		4 PCS	F	CREW Ø4 x 45mmL		24 PCS
7	CHAIR BACK		4 PCS	G	ALLEN KEY		4 PCS
							Not Included

## ASSEMBLY INSTRUCTIONS

STEP 1:

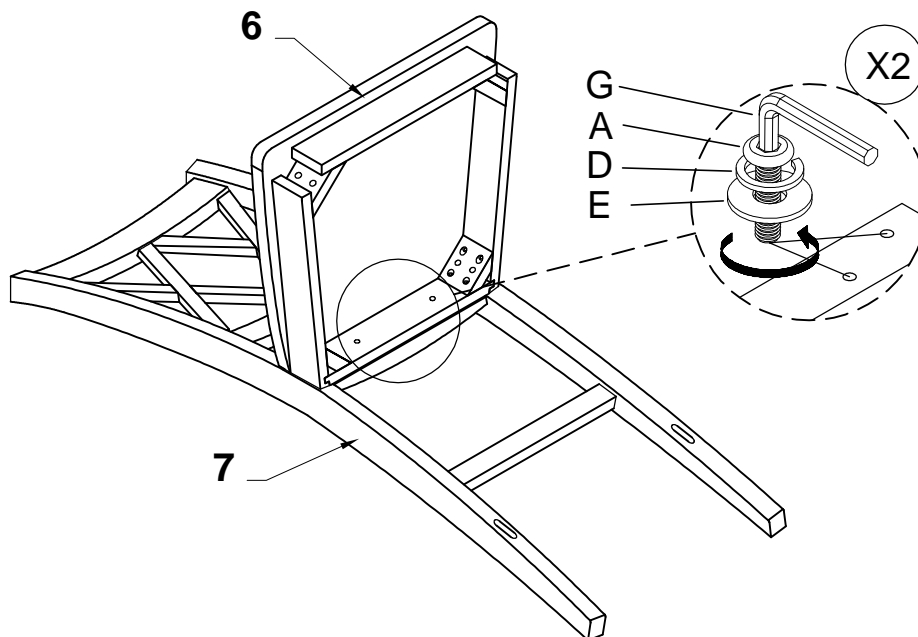

# ASSEMBLY INSTRUCTIONS

STEP 2:

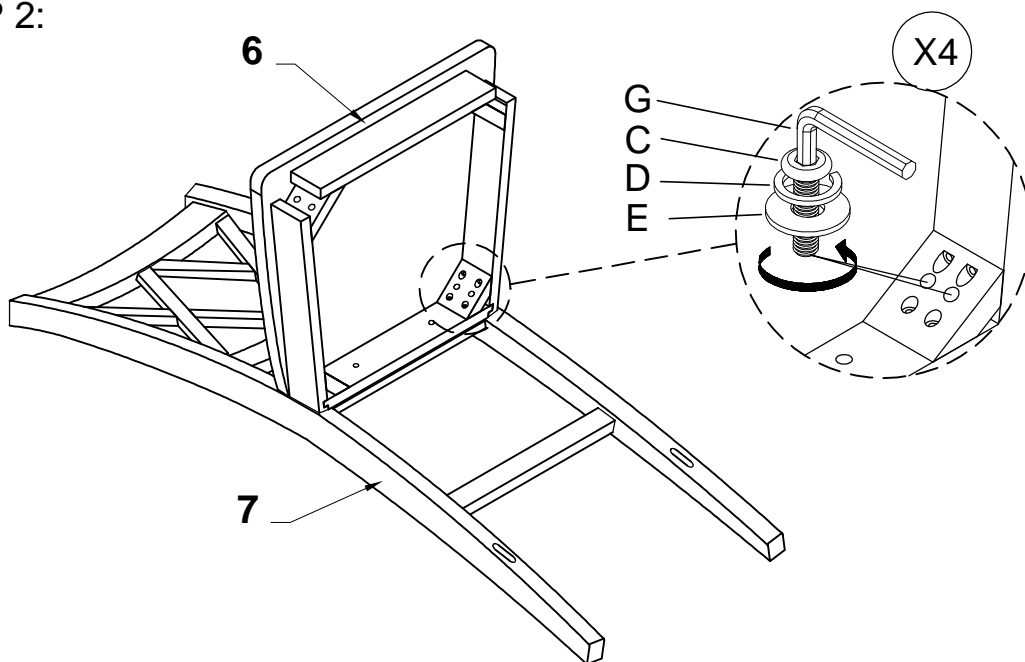

STEP 3:

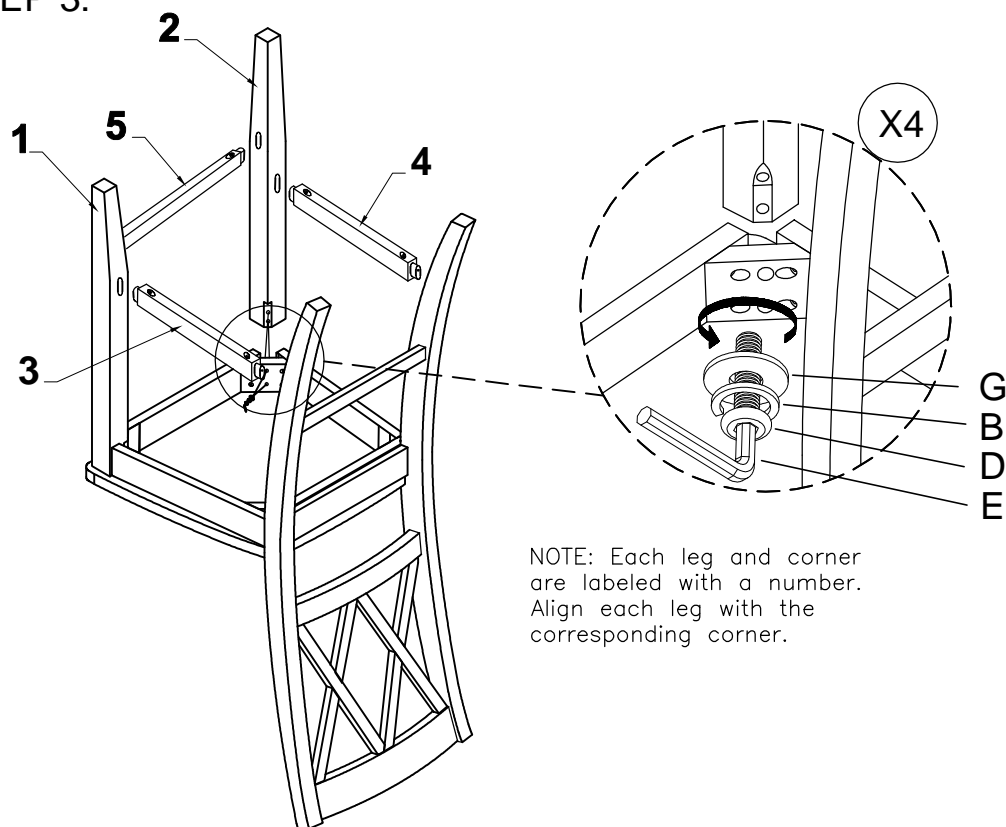

NOTE: Each leg and corner are labeled with a number. Align each leg with the corresponding corner.

# ASSEMBLY INSTRUCTIONS

STEP 4:

