















CHAIR & TABLE COMPANY

ASSEMBLY INSTRUCTION RTA HUDSON 24" COUNTER STOOL

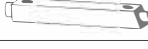
Parts List				Hardware List			
No.	Description	Picture	Qty	No.	Description	Picture	Qty
A	CHAIR BACK		1 Pc	H	JCBC M6 x 80mm		4 Pcs
B	SEAT		1 Pc	I	JCBC M6 x 60mm		4 Pcs
C	FRONT LEG (L)		1 Pc	J	JCBC M6 x 40mm		3 Pcs
D	FRONT LEG (R)		1 Pc	K	LOCK WASHER Ø1/4"		11 Pcs
E	SIDE STRETCHER (L)		1 Pc	L	FLAT WASHER Ø1/4" 19mm		11 Pcs
F	SIDE STRETCHER (R)		1 Pc	M	PH SCREW M4 x 38mm		6 Pcs
G	FRONT STRETCHER		1 Pc	N	ALLEN KEY M4		1 Pc

PHILLIPS HEAD SCREWDRIVER TOOL NEEDED (NOT INCLUDED) 

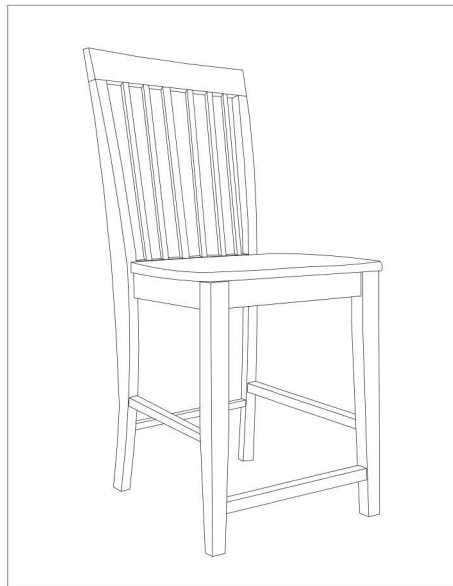

STEP 1

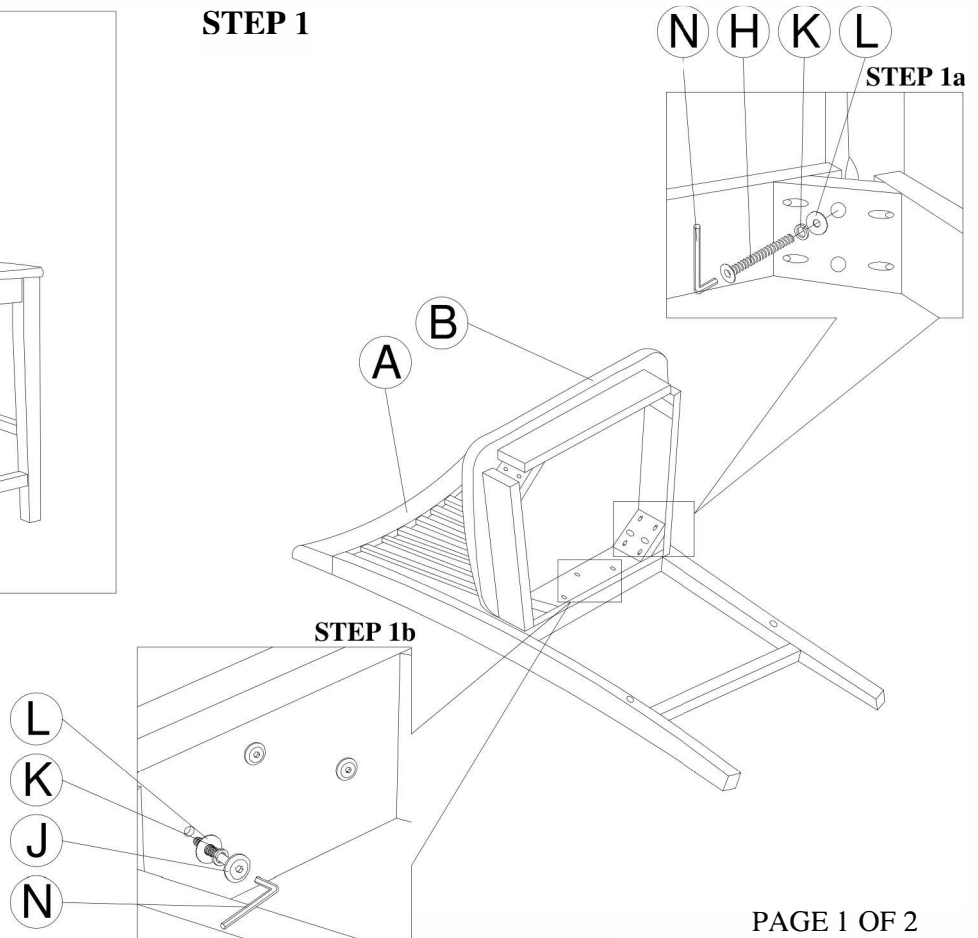

STEP 2

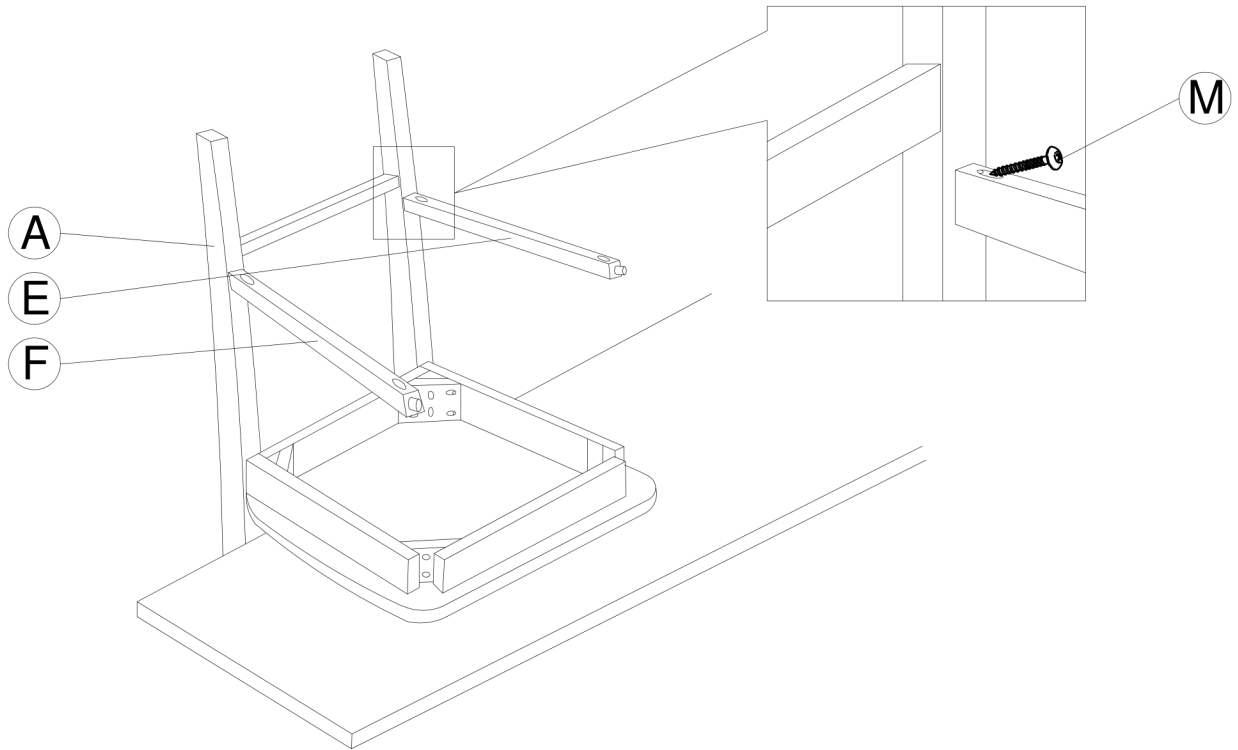

NOTE : DO NOT TIGHTEN SCREW AND BOLTS ALL THE WAY AT THIS TIME

STEP 3

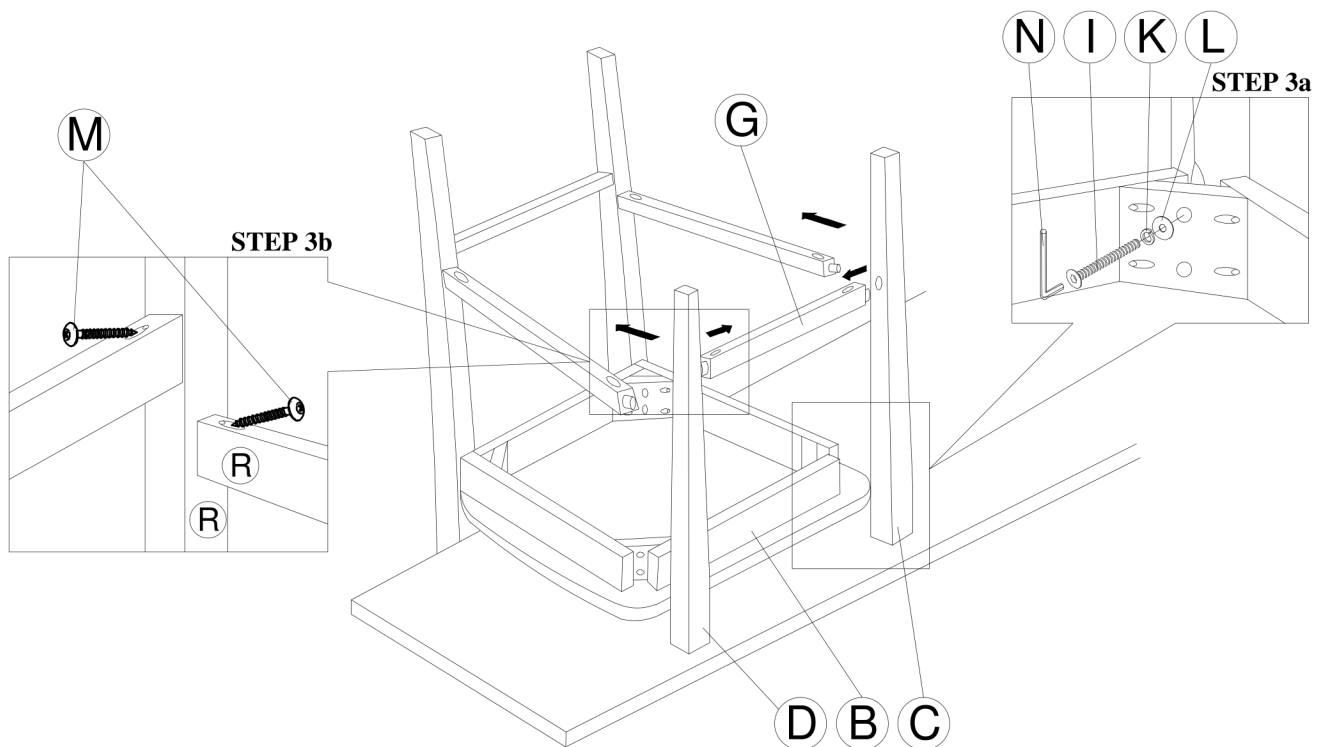

NOTE : ALL SCREW AND BOLTS MUST BE TIGHTENED ALL WAY (100%)