

Assembly Instructions

Sit Stand Desks

First – a few words of advice and caution:

1. Please do this job with two people. Attempting to do it alone, though heroic, could lead to product damage or injury because some things might be too heavy or awkward for just one person to safely handle. With two people, the job will be much smoother and safer – and a lot more fun!
2. Please read and follow these written instructions carefully, as it will save time and avoid possible incorrect set-up of the product.
3. Please do not over-tighten screws and bolts, as it may lead to “stripping” the threads and make the connection weak. The best rule is “firm and snug is what we need”.
4. If you will be installing your Sit Stand Desk on a hard surface such as stone, hardwood floor, tile, (anything other than carpet), please lay down enough padding to lay the parts on while assembling. This will protect the Sit Stand Desk parts from the floor, and vice versa. We recommend enough blankets, comforters, moving blankets, etc., to cover an area of about 6 feet by 6 feet.

TOOLS & THINGS YOU NEED TO SUPPLY:

To assemble your new desk, we have supplied the K180 Allan that you will find in the bubble pack from box #1.

To attach the K182 with K123 screws, you will need to supply a #2 Phillips screwdriver.

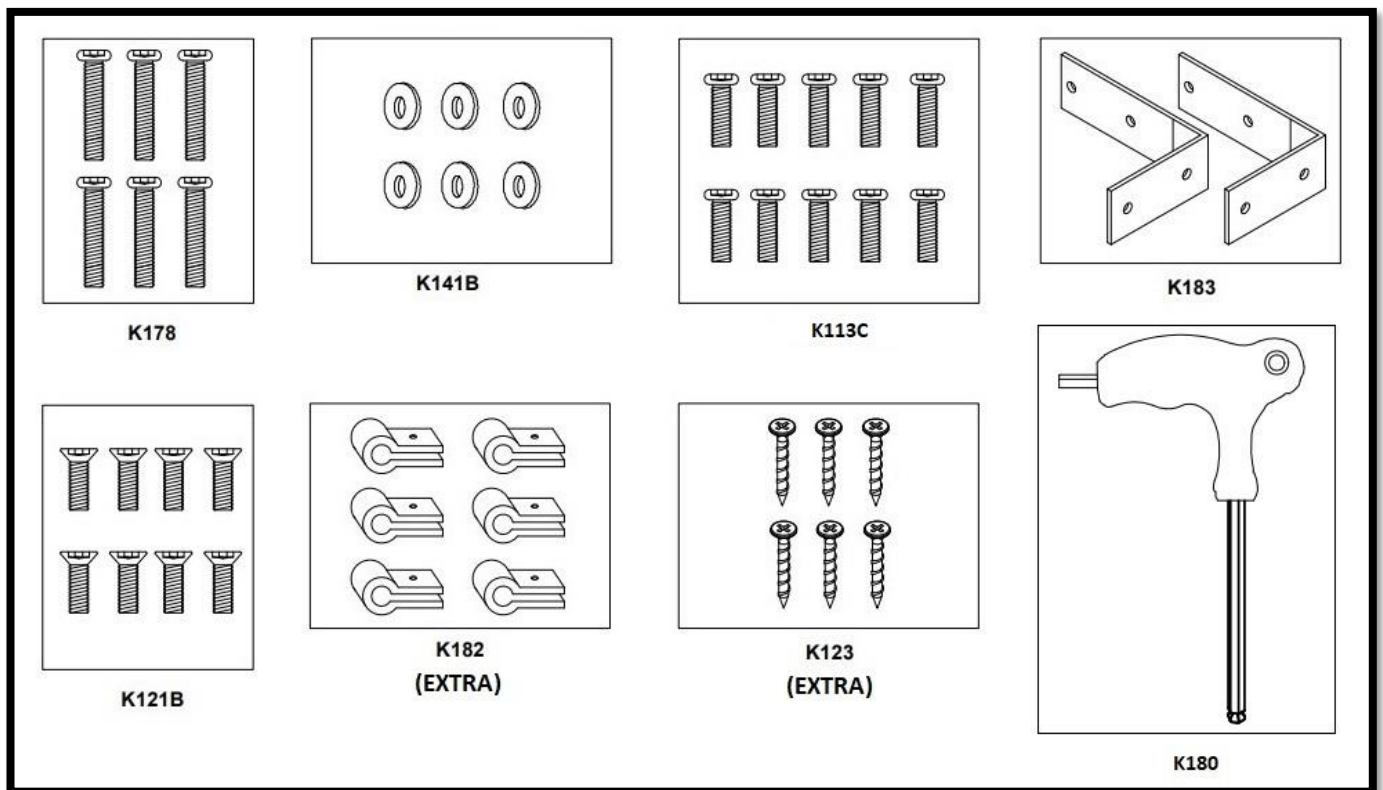

Sit Stand Assembly Instructions

1. Unpack all three boxes and place the drawer bases where you will be using your completed desk, spread 36" apart. The correct position of the lift legs will orient toward the inside ends. They are right side and left side bases.

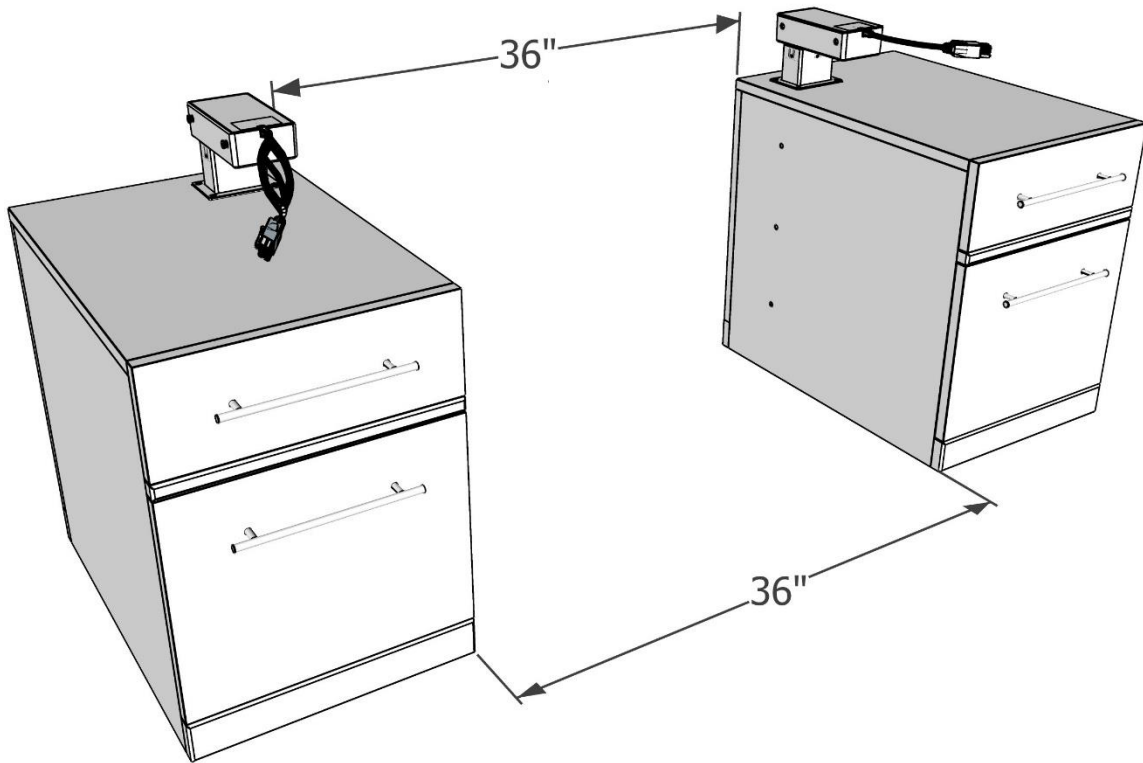

2. Attach the fixed modesty panel (the smaller panel) to the drawer bases using the K178 bolts with K141B washers. To avoid stripping the bolt threads, finger-start the bolts before you tighten them with the K180 Allan Wrench.

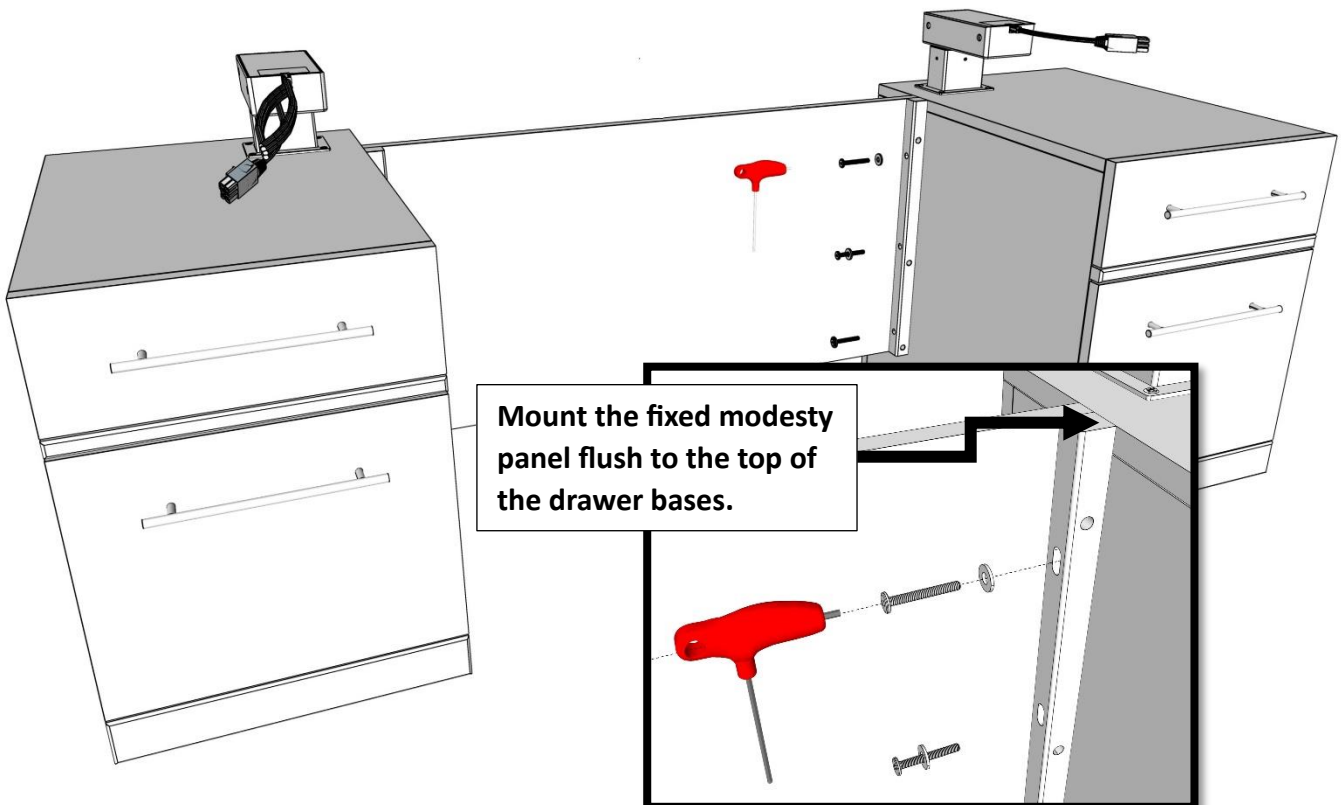

3. Now lay out a blanket, or some form of padding, onto the floor and place the desktop on it with the topside down, as shown.

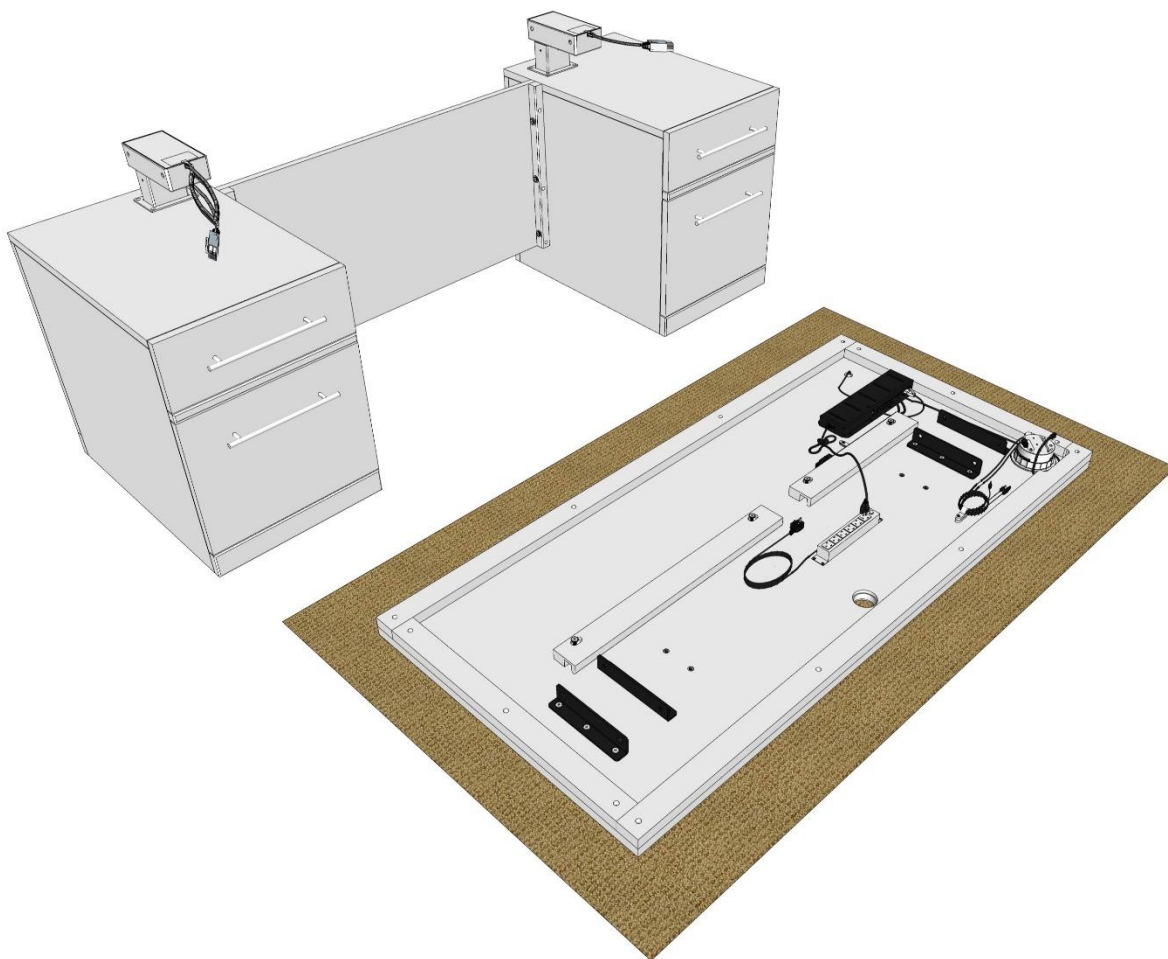

4. Plug the controller box's electrical cord into the power strip.

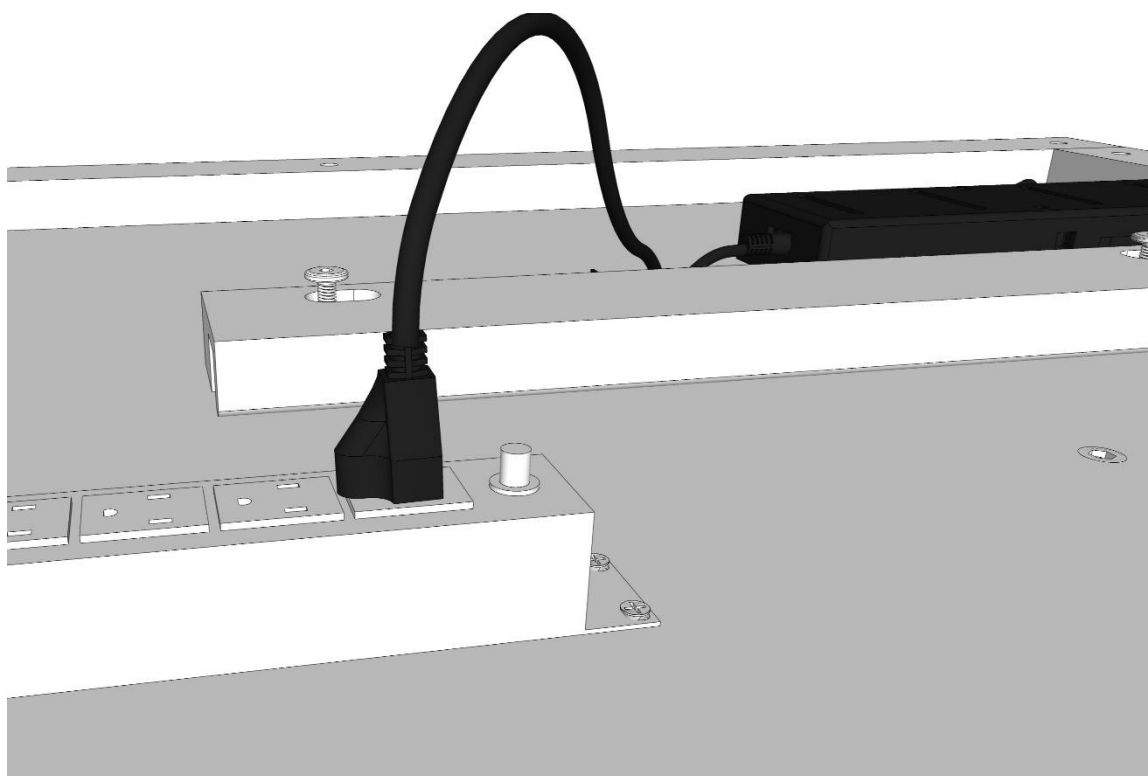

5. Connect the power plug, from the controller box, into the pop-up phone charger/PC hub.

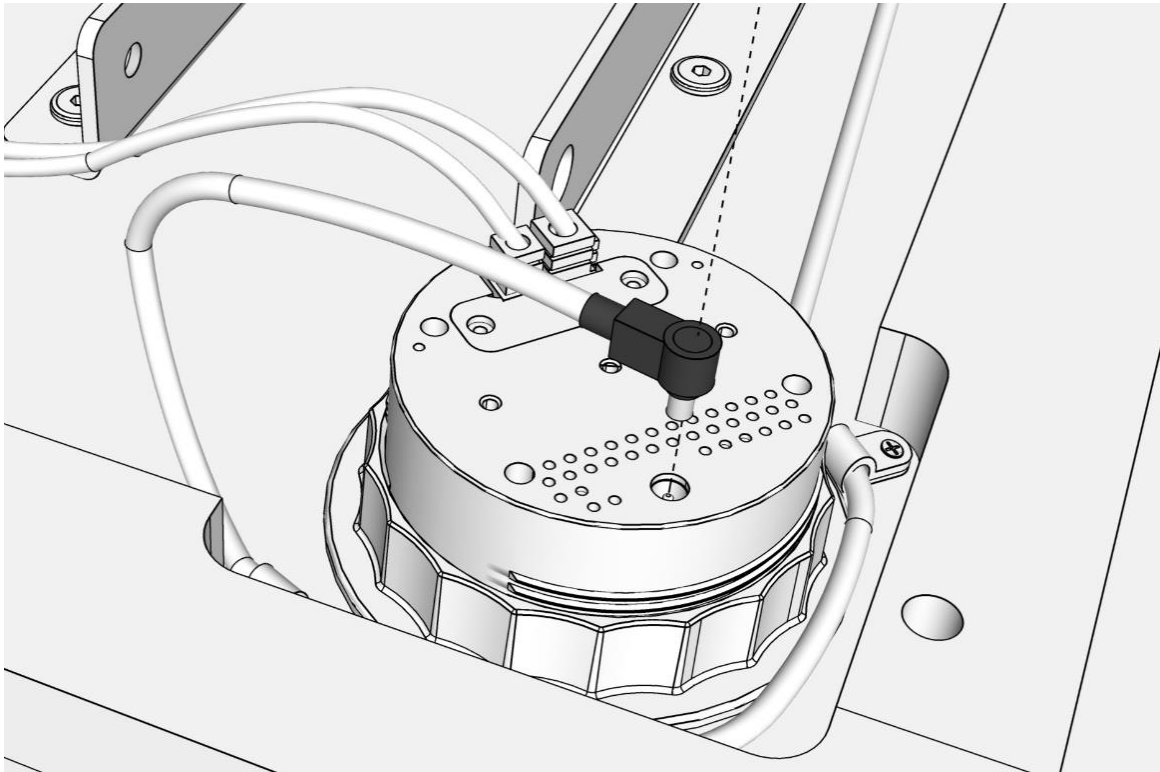

6. Attach the K183 angle brackets to the desktop using the K177 bolts.

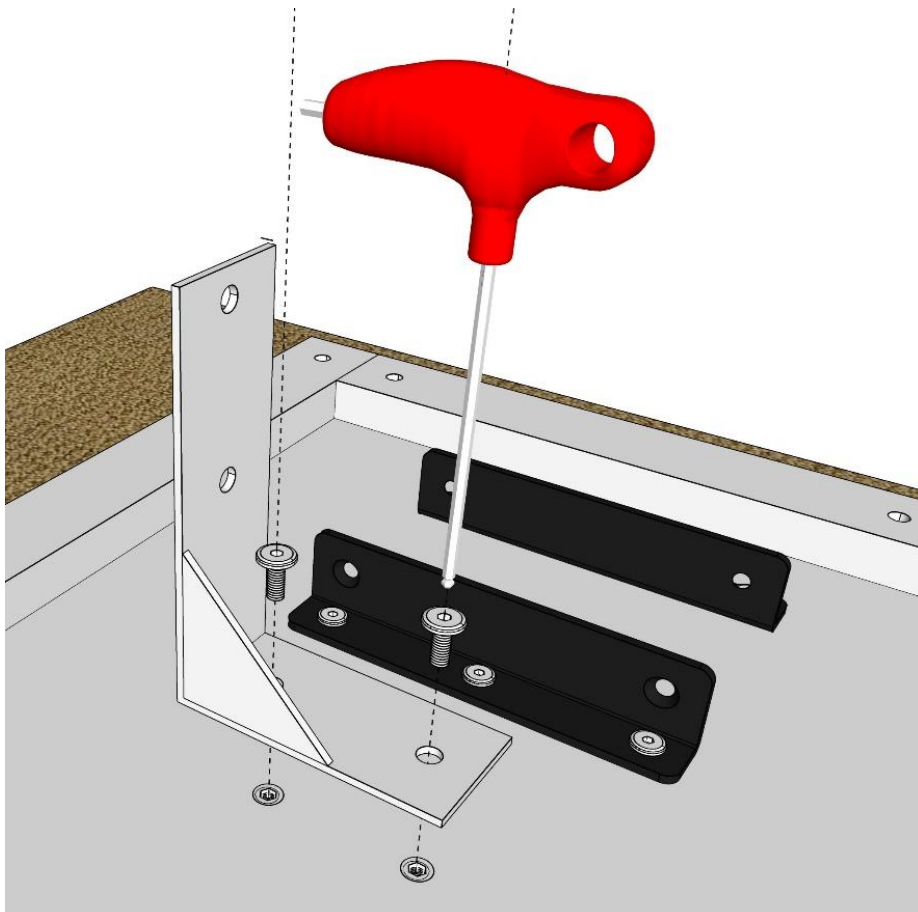

7. Where you have positioned the desk, in relation to power outlet you will plug your desk into, will determine which direction that you run the desk's power cord. You have 3 options on how you can manage the direction that you will run your power cord:
- Option A is to run the power cord to plug into the wall outlet on the left side.
 - Option B is to run the power cord to plug into the wall outlet on the right side.
 - Option C is to run the power cord to plug into the wall outlet behind the desk, which will be extended through the mouse hole in the modesty panel.

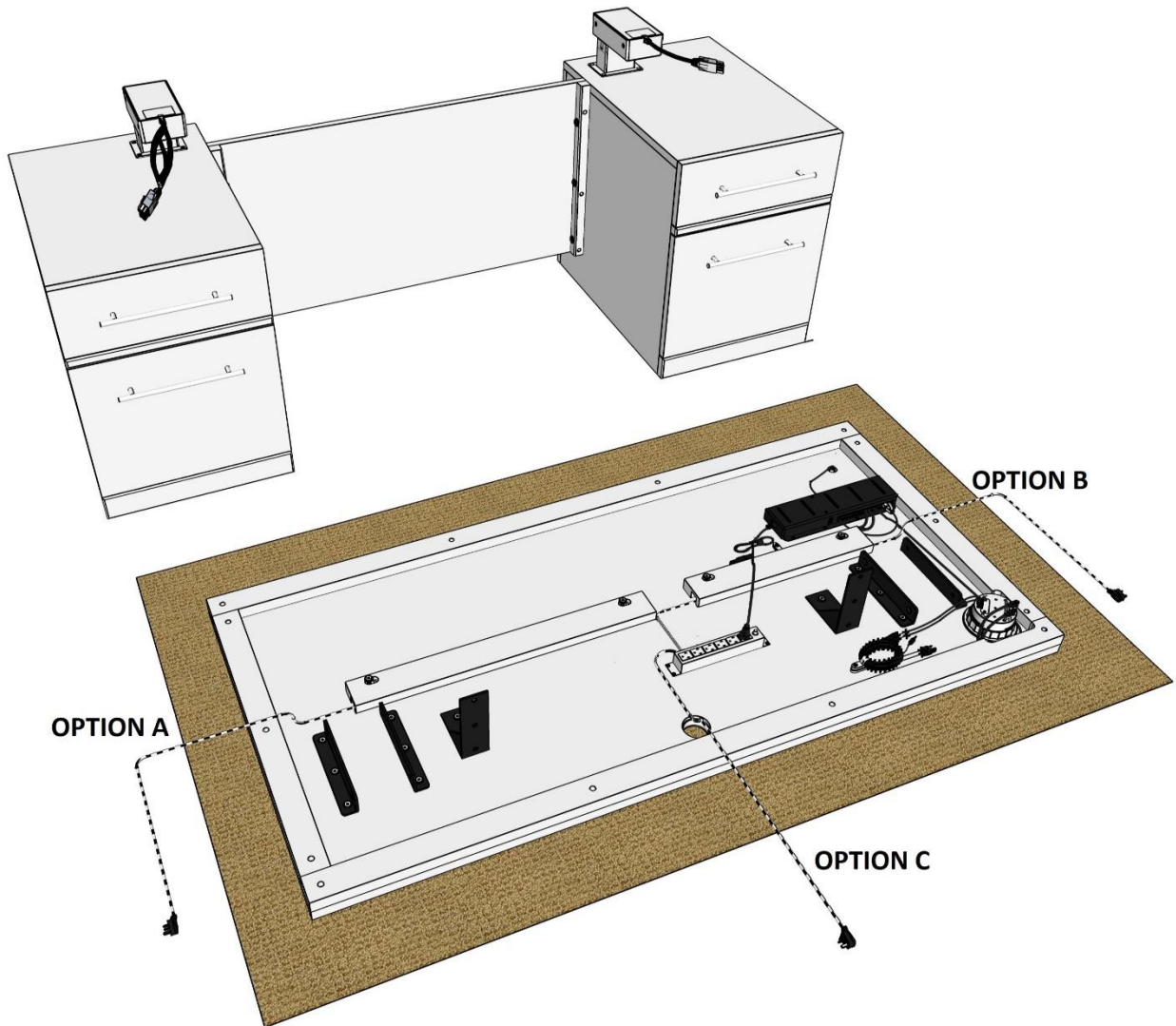

8. If you choose either option A or B, loosen (but do not remove) the bolts on the wire management track, and slip the power cord into it. The smaller of the two tracks can be snugged up not used for the power cord. If you have used the larger track to run the power cord to the left side, leave that track loose. You have one more wire to put into the track in step #13

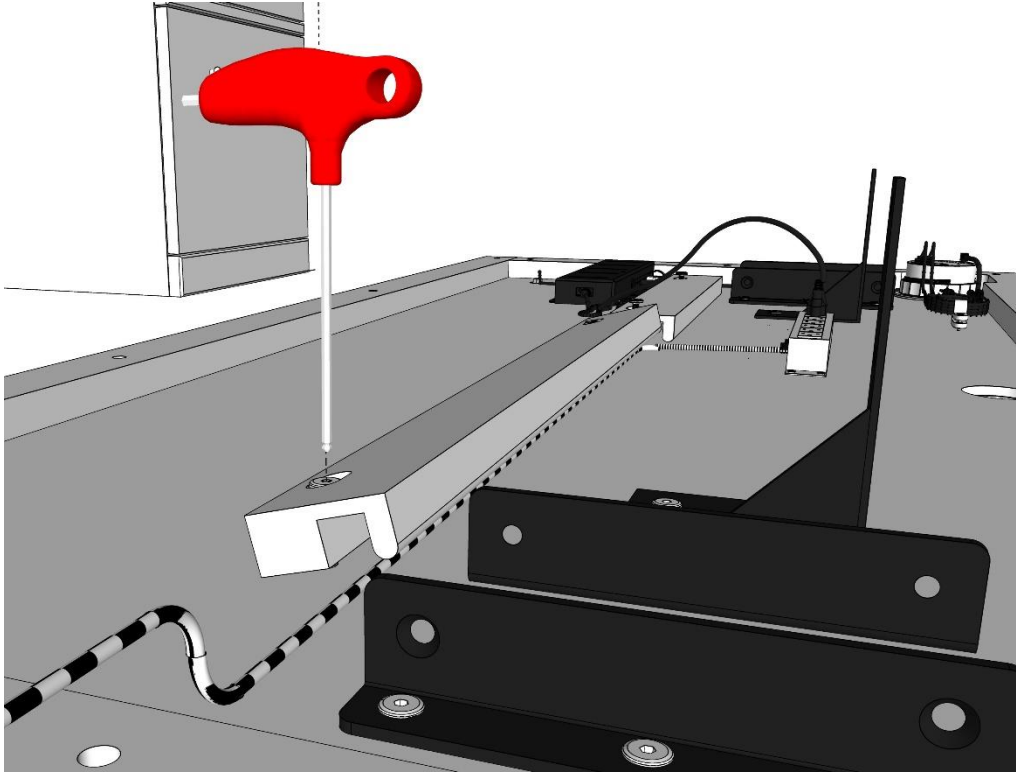

9. From the top drawer of each drawer base, remove the honeycomb cardboard blocks and place them on the outer front corners of the drawer bases.

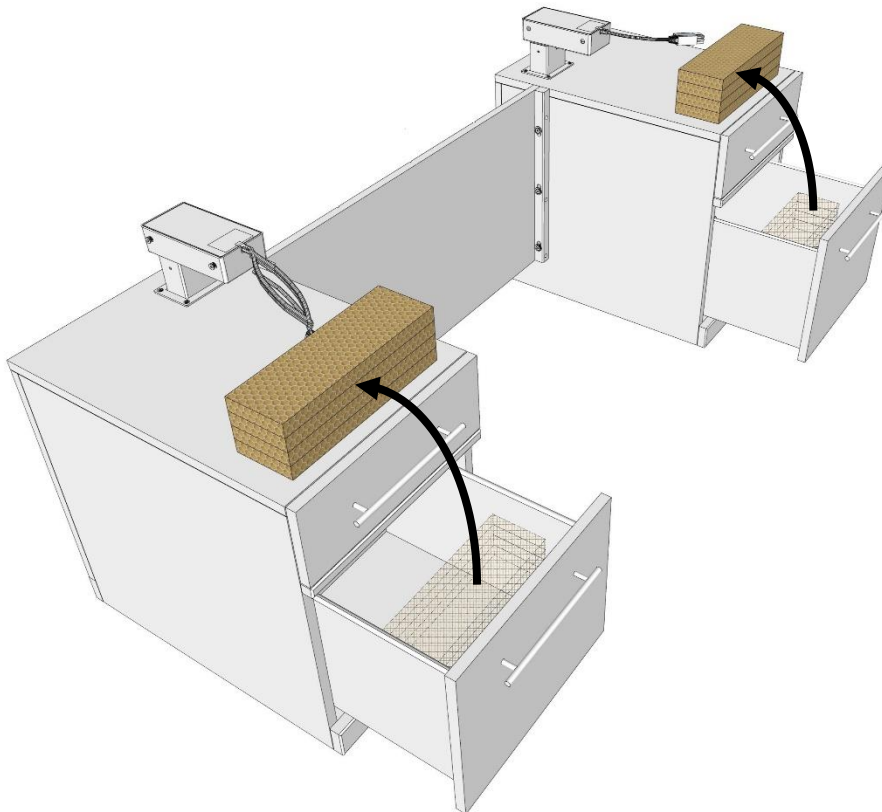

10. Carefully lift the top, flip it over and set the desktop onto the lift legs and honeycomb blocks.

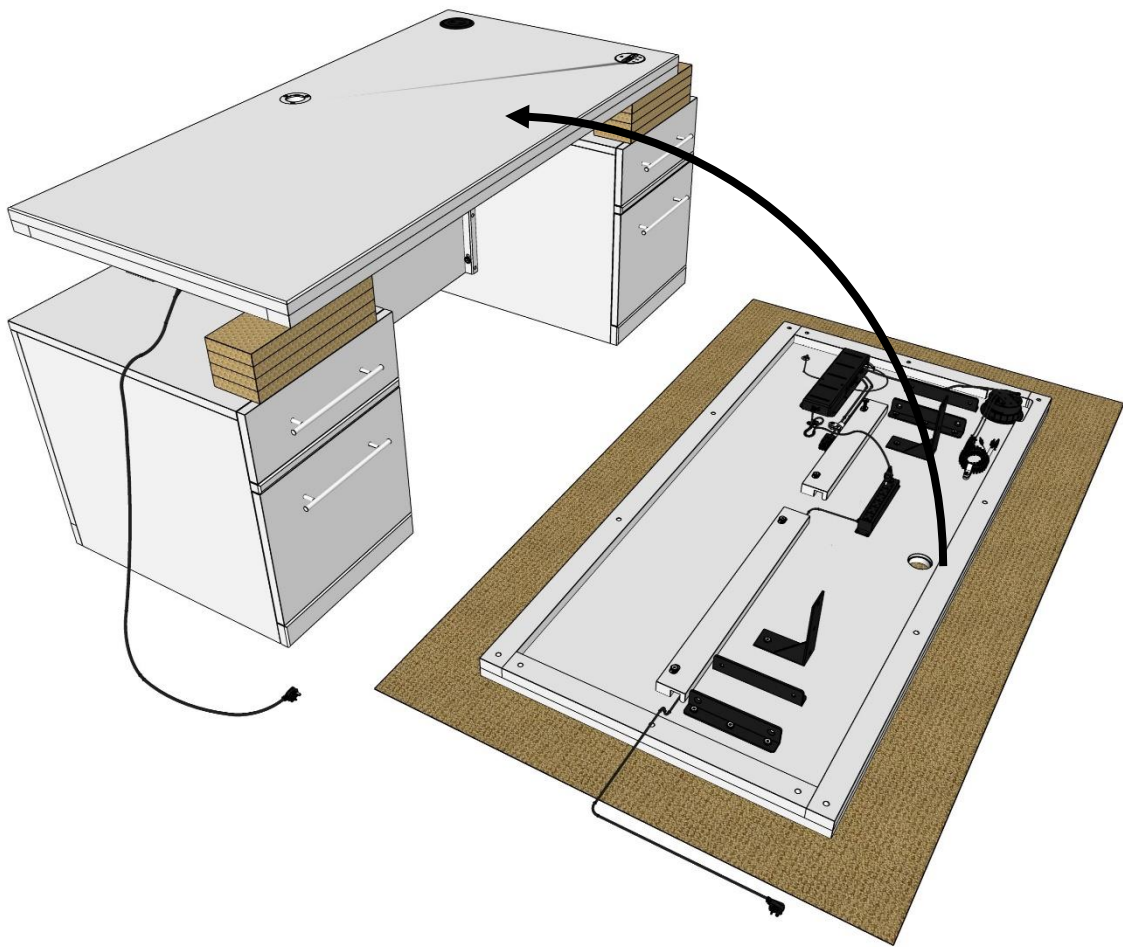

11. Align the holes used to connect the desktop to the lift legs and connect the top to the lift legs using the K121B screws. Finger-start the screws and then tighten them up, using the supplied K184 Allen wrench.

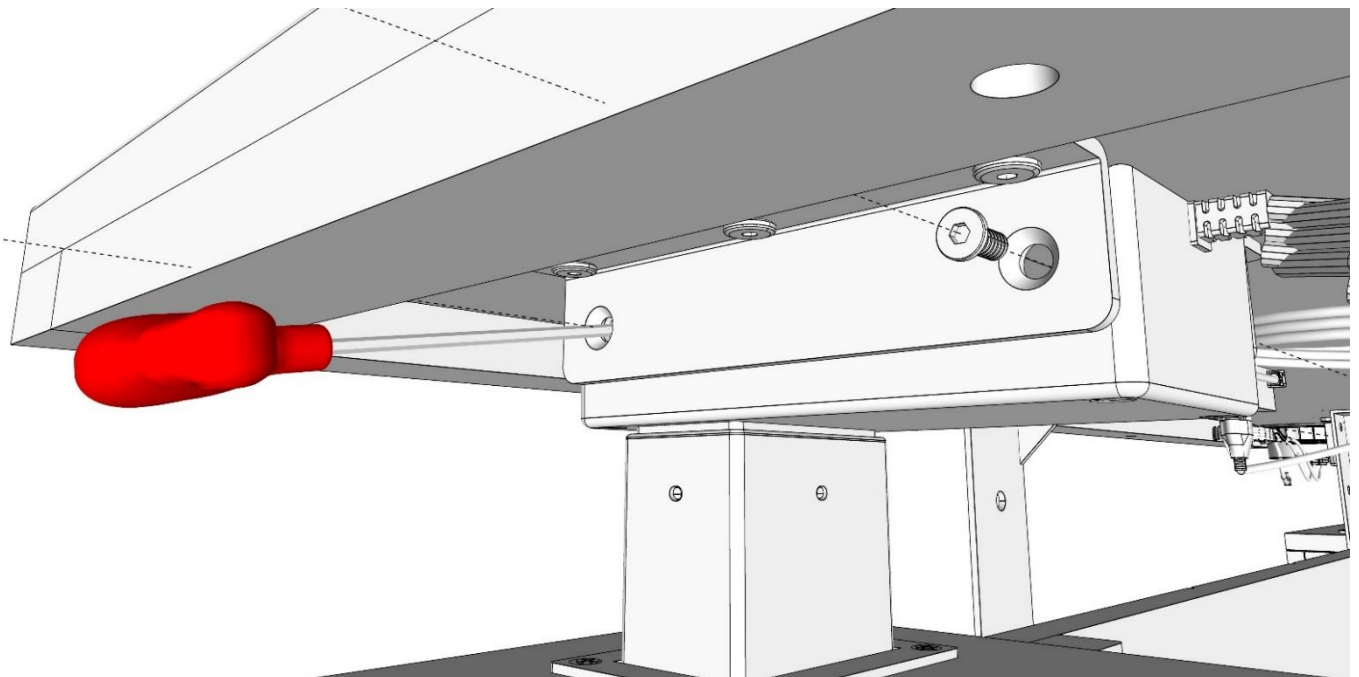

12. **Step 1** - From the underside of the desktop, connect the two power/controller wires from the legs to the matching wires coming from the controller.
- Step 2** - These wires will hang a little, so you will need to install two of the wire management clips as necessary, to secure them to the underside of the desktop.

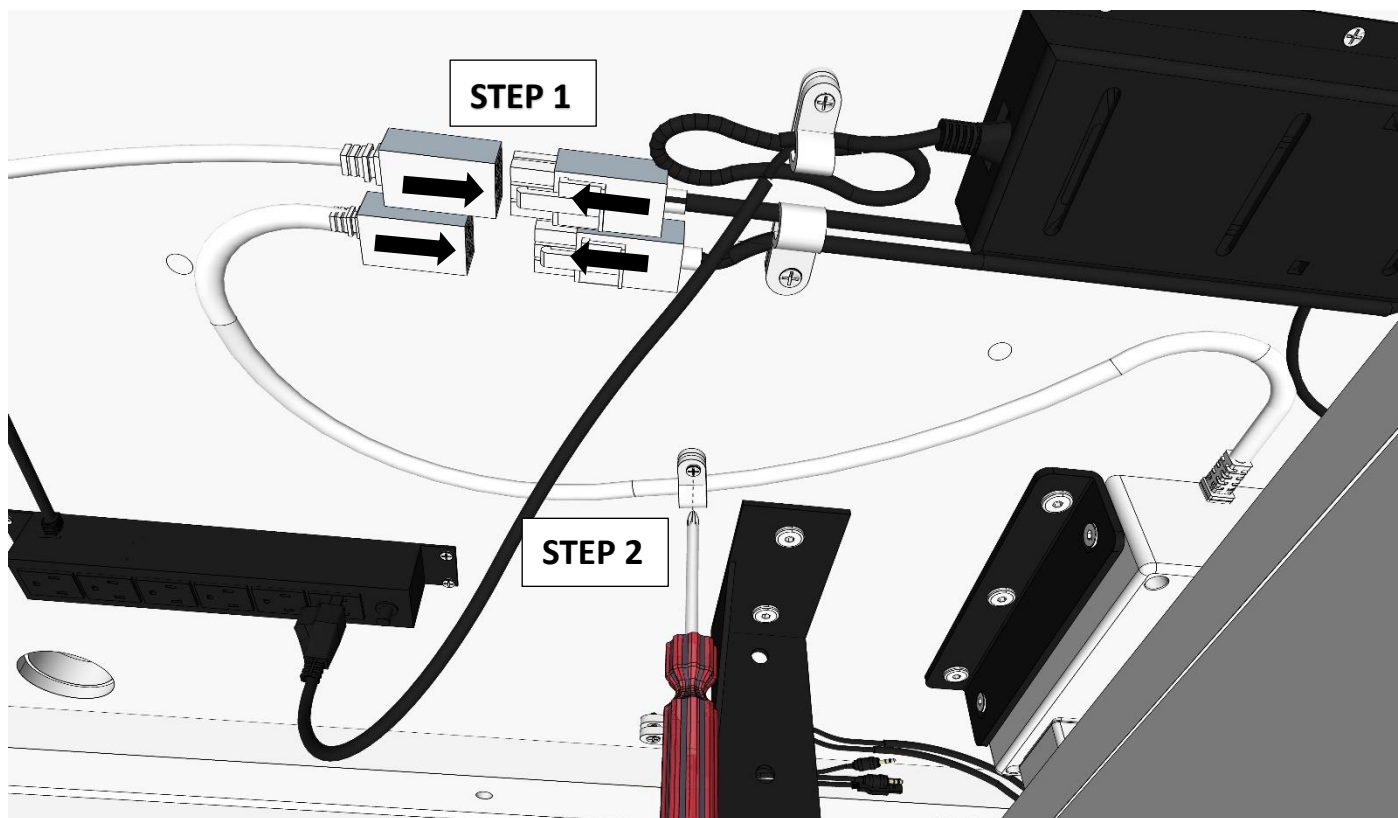

13. Slip the longer power/controller wire, that you just connected, into the longer of the wire management tracks and snug the bolts on the track.

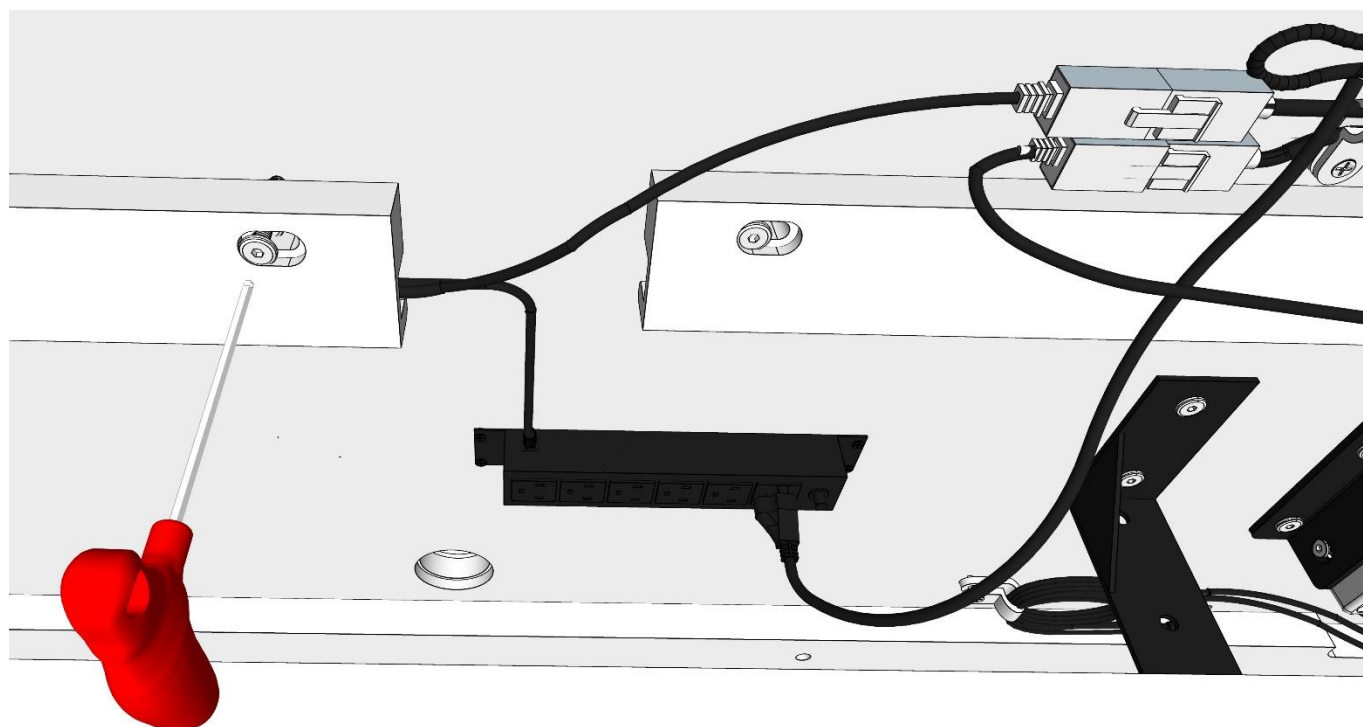

14. *** **YOU MUST SYNCHRONIZE THE LIFT LEGS, before moving on to step #15. Synchronize the lift legs as follows:**

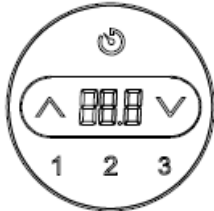

Handset Instruction	
Button	Functionality
	REMINDER button, to activate the " Long-Time Sitting Reminder " function
	UP Button, to lift the desk surface
	DOWN Button, to lower the desk surface
	LED Display
1	Position 1, User saves the 1st Height Position
2	Position 2, User saves the 2nd Height Position
3	Position 3, User saves the 3rd Height Position
	Child Lock , to Lock/Unlock height position, and factory reset purpose.

Operation Guide

- Reset Process
 - a. Factory reset is required for first time initialization or when power cut off due to electrical problems.
 - b. Make sure all cables are connected properly before initialization.
 - c. Press and hold the "" button. Please do not release the button until connects to power.
 - d. LED display shows "RES" then release the "" button, desktop goes down automatically until it reaches its lowest height then rebound to factory reset height.
 - e. LED display shows "h0E", the initialization is completed.
- After the reset process, press the **UP** or **DOWN** button to lift or lower the height of desktop. The LED display shows the real time numerical value. The range of numerical value: 28.5"-47.2".
- Memory setting for height position
 - a. Press the **UP** or **DOWN** button to lift or lower height of desktop.
 - b. You can adjust the height to 35"then press button "1" for 5 seconds, LED display starts flashing and you saved the 1st height position to 35".
 - c. Repeat the same process to save 2nd and 3rd height position accordingly.
 - d. Press button "1", "2" and "3" to reach the saved height position.
- Long-Time Sitting Reminder
 - a. Press REMINDER button "" to activate the function. The LED display start flashing and shows "00"
 - b. Press **UP** or **DOWN** button to adjust countdown time setting. Re-press the "" button to confirm and LED display stops flashing, countdown timing is set.
 - c. When the countdown finished, the buzzer will activate automatically with sound.
 - d. To de-activate the countdown, press "" button and set timing to "00" by using the **UP** or **DOWN** button, then press "" button to confirm.
- The button is to lock height position from preventing further adjustment. To unlock it, simply press it again.

15. Raise the desktop to its maximum height using the controller on the desktop. Now you can access the underside of the desk more easily for the final assembly steps.

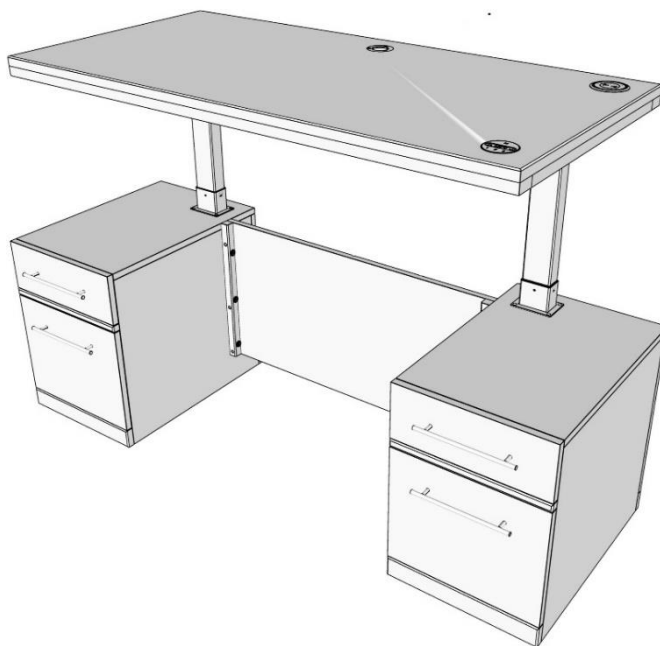

16. Attach the floating modesty panel to the angle brackets using the K177 bolts.

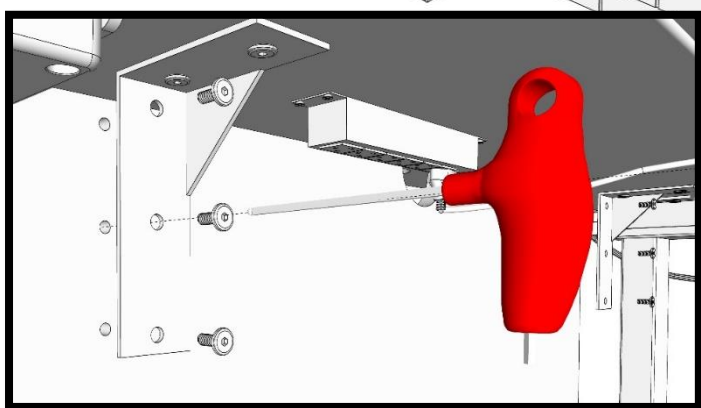
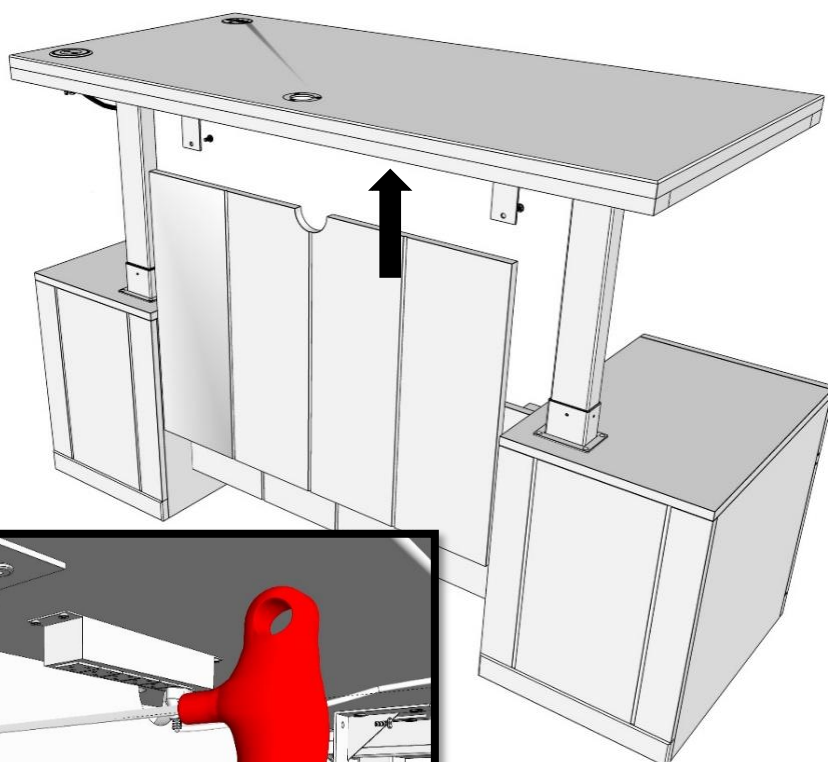

Congratulations, your Sit Stand Desk is now complete!

Pop-up wireless cell phone charger/ PC Hub

