

# ASSEMBLY INSTRUCTIONS

## Upholstered Queen Bed

ASSEMBLY  
REQUIREMENTS

2-Person  
Assembly

1 Hour  
Assembly Time  
(Approximate)

Tools Required  
(Not Provided)

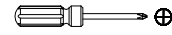

Phillips Screwdriver



Flat Screwdriver

Thank you for purchasing our product!

Please refer and use this assembly instruction to assemble the product. Contact our customer service department in case there are any missing or damage parts or hardware. Replacement parts are normally shipped within 2 or 3 days.

Within 30 days from delivery date

**PRODUCTS PURCHASED THROUGH OUR AUTHORIZED VENDORS ONLY ARE ELIGIBLE FOR REPLACEMENT PARTS.**

We appreciate your business!

**THIS PRODUCT IS FOR INDOOR AND HOUSEHOLD USE ONLY - NOT FOR COMMERCIAL USE.**

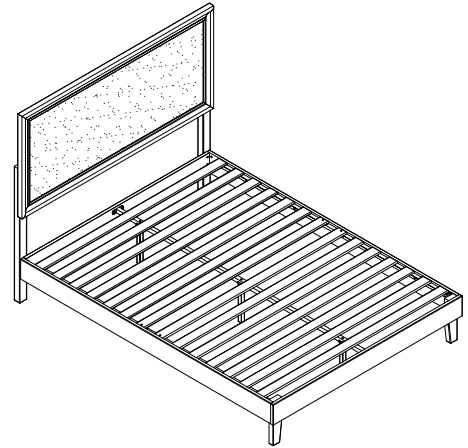

### ASSEMBLY PREPARATION

1. Remove all packaging materials, staples and packing straps from the carton.
2. Refer to Parts List and Hardware List, and ensure parts and hardware are correct before assembly. Contact customer service for missing parts.
3. Place all wooden parts on a clean, flat and soft surface (e.g. carpet or rug) to prevent scratch and damage to parts.

### SAFETY PRECAUTION

1. KEEP ALL HARDWARE PARTS OUT OF REACH OF CHILDREN.
2. DISPOSE PLASTIC PACKAGING MATERIAL IMMEDIATELY TO AVOID ANY RISK OF SUFFOCATION TO CHILDREN AND ANIMALS.

### TIPS FOR ASSEMBLY





1. Allow ample room for assembly and assemble the product near where product will be placed.
2. Assemble the product on a surface that does not scratch or damage the exterior gloss and finish of the furniture.
3. Identify all of the parts, hardware and quantities required for each step.
4. During assembly, do not over-tighten any fittings as this may cause damage.
5. DO NOT USE POWER TOOLS TO ASSEMBLE THIS PRODUCT.
6. Always place the product on a flat, level surface.
7. Do not sit or stand on the partially assembled product; only use the product for which it is intended.

### CARE AND MAINTENANCE

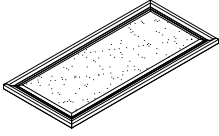
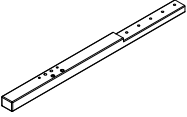
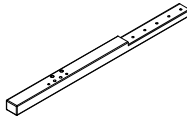
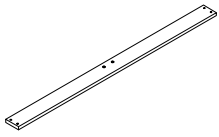
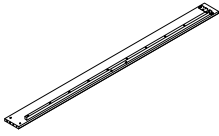
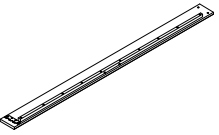



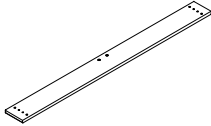
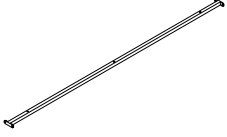

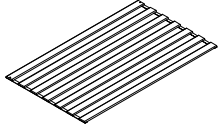

- Use a slightly damp cloth to clean the product. Do not use bleach or abrasive cleaning material.
- Check all the fittings periodically and re-tighten as necessary. Do not use the product if any of the parts is damaged or broken.
- Never allow any kind of liquid to remain on your furniture. Absorption can cause wood to warp or delaminate.
- Do not place hot items (e.g. hot drinks) directly onto the wood surface.
- Do not drag and/or pull the furniture.

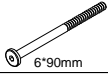
# Parts List

ITEM	DESCRIPTION	PART	QTY
1	Headboard		1pc
2	Headboard Left Leg		1pc
3	Headboard Right Leg		1pc
4	Cross Bar		1pc
5	Left Sideboard		1pc
6	Right Sideboard		1pc

ITEM	DESCRIPTION	PART	QTY
7	Footboard Left Leg		1pc
8	Footboard Right Leg		1pc
9	Footboard		1pc
10	Center Support		1pc
11	Metal Leg		3pc
12	Slats		2pc

# Hardware List

ITEM	DESCRIPTION	HARDWARE	QTY	ITEM	DESCRIPTION	HARDWARE	QTY
<b>A</b>	Screw	 6*90mm	4pcs	<b>E</b>	Screw	 8*50mm	10pc
<b>B</b>	Barrel Nut	 6*23mm	4pcs	<b>F</b>	Washer	 8*22mm	21pcs
<b>C</b>	Screw	 8*20mm	4pcs	<b>G</b>	Wood Dowel	 8*30mm	8pcs
<b>D</b>	Screw	 8*35mm	7pcs	<b>H</b>	Allen Key		1pcs

## Instructions For Barrel Nut

Insert Barrel Nut with the perpendicular hole facing and in-line with the drill hole that the bolt is to be inserted.

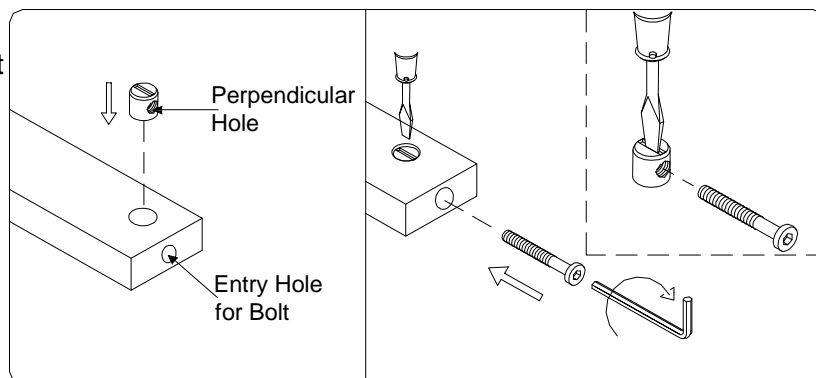

Use a Flathead Screwdriver to hold Barrel Nut in position before inserting bolt to thread into the Barrel Nut.

# Parts Assembly Overview

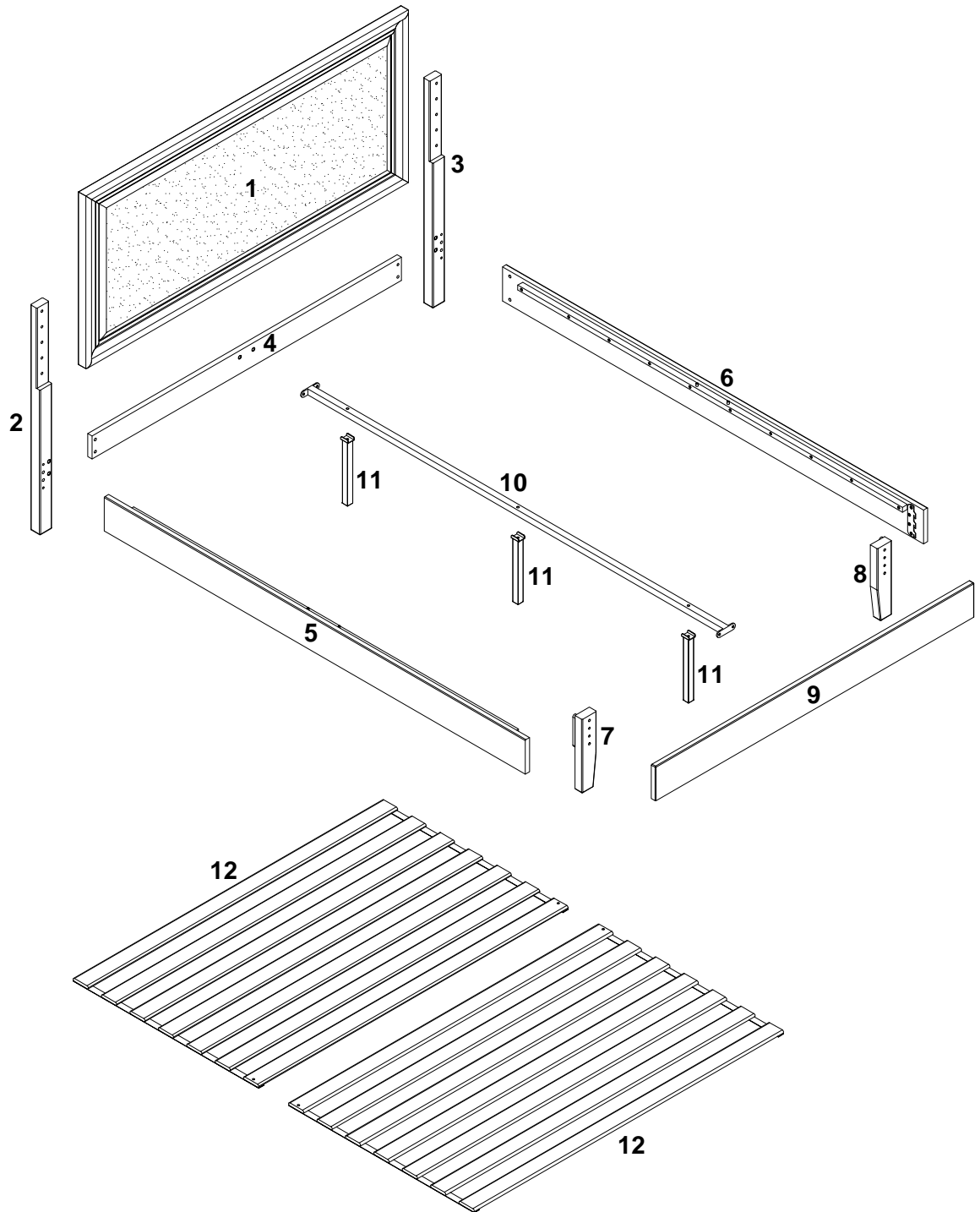

## STEP 1

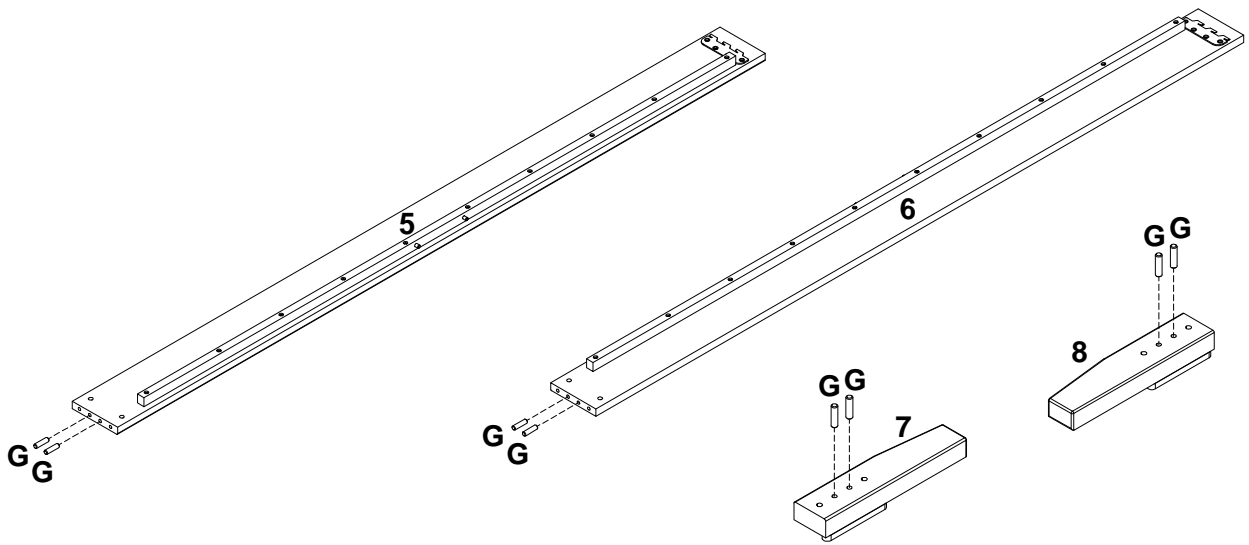

Insert Wood Dowel (G) into the designated holes on Left Sideboard (5), Right Sideboard (6) and Footboard Left & Right Leg (7 & 8) as shown.

## STEP 2

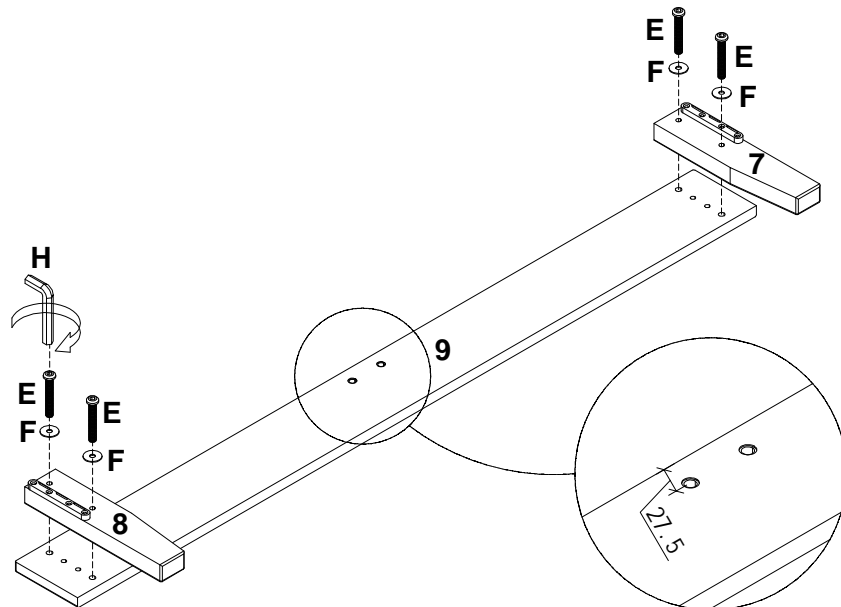

- Place Footboard (9) as shown on a material that does not scratch or damage the part.
- Attach Footboard Left & Right Leg (7 & 8) from STEP 1 to (9) via wood dowels on (7 & 8). Note the orientation of the parts.
- Use Screw (E) fitted with Flat Washer (F) to fasten (8) to (9). Use Allen Key (H) to drive and tighten (E).

### STEP 3

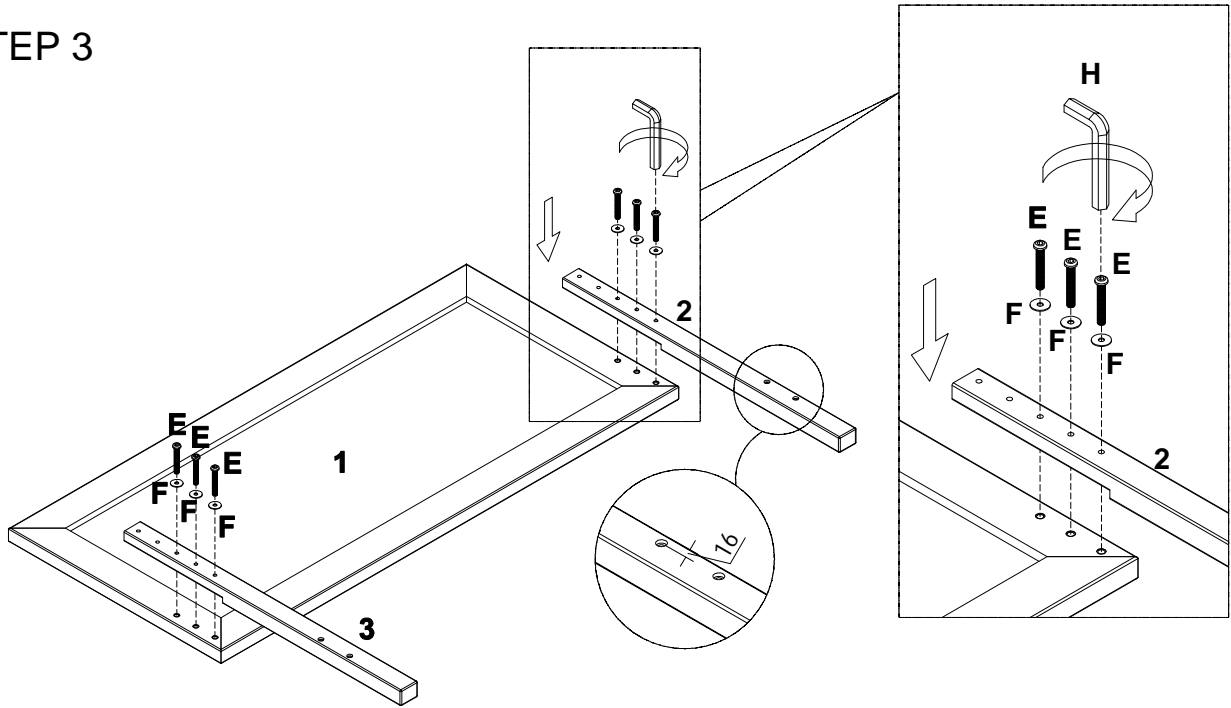

- Place Headboard (1) as shown on a material that does not scratch or damage the part.
- Align the 3 screw holes on Headboard Left & Right Leg (2 & 3) to the 3 screw holes on (1). Check that the lap edge of (2 & 3) is against the the left and right bottom corner of the headboard.
- Use Screw (E) fitted with Flat Washer (F) to fasten (2 & 3) to (1). Use Allen Key (H) to drive and tighten (E).

### STEP 4

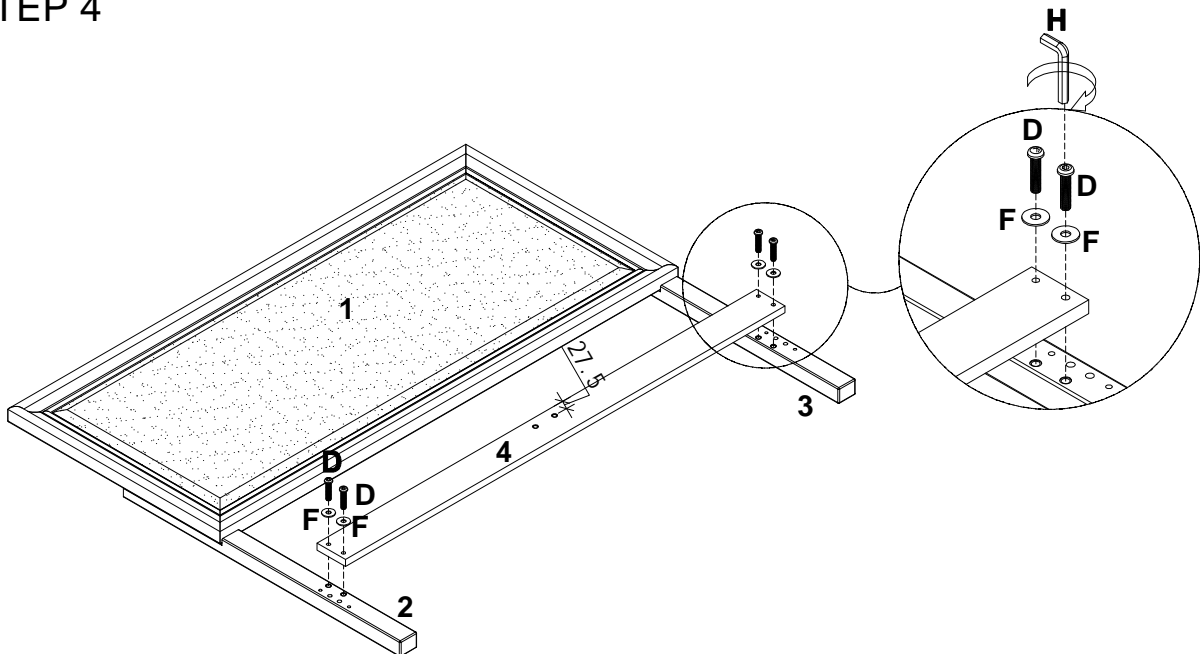

- Place Headboard (1) from STEP 3 as shown
- Align the 2 screw holes at each end of Cross Bar (4) to the 2 screw holes on the inside edge of Headboard Left & Right Leg (2 & 3). Note the orientation of (4) with respect to the 2 screw holes at the center of (4).
- Use Screw (D) fitted with Flat Washer (F) to fasten (4) to (2 & 3). Use Allen Key (H) to drive and tighten (D).

## STEP 5

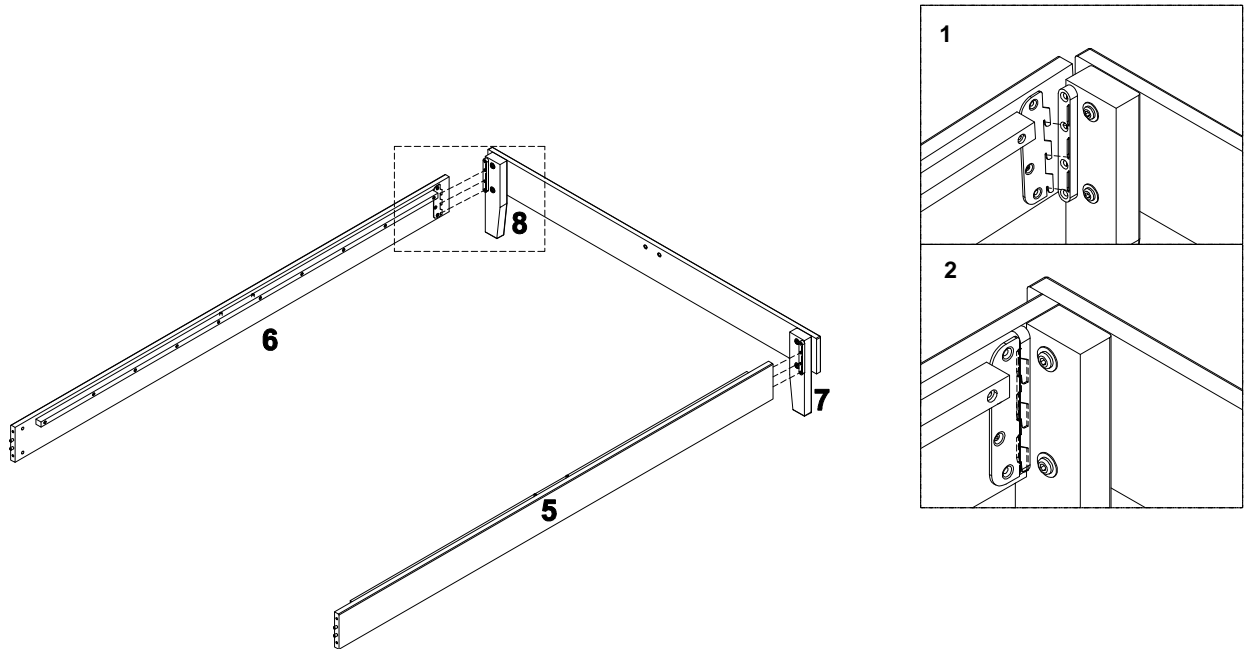

With assistance attach Left Sideboard (5) to the Footboard Left Leg (7) via hook and slot on the respective parts. Next, attach Right Sideboard (6) to the Footboard Right Leg (8) via hook and slot on the respective parts.

## STEP 6

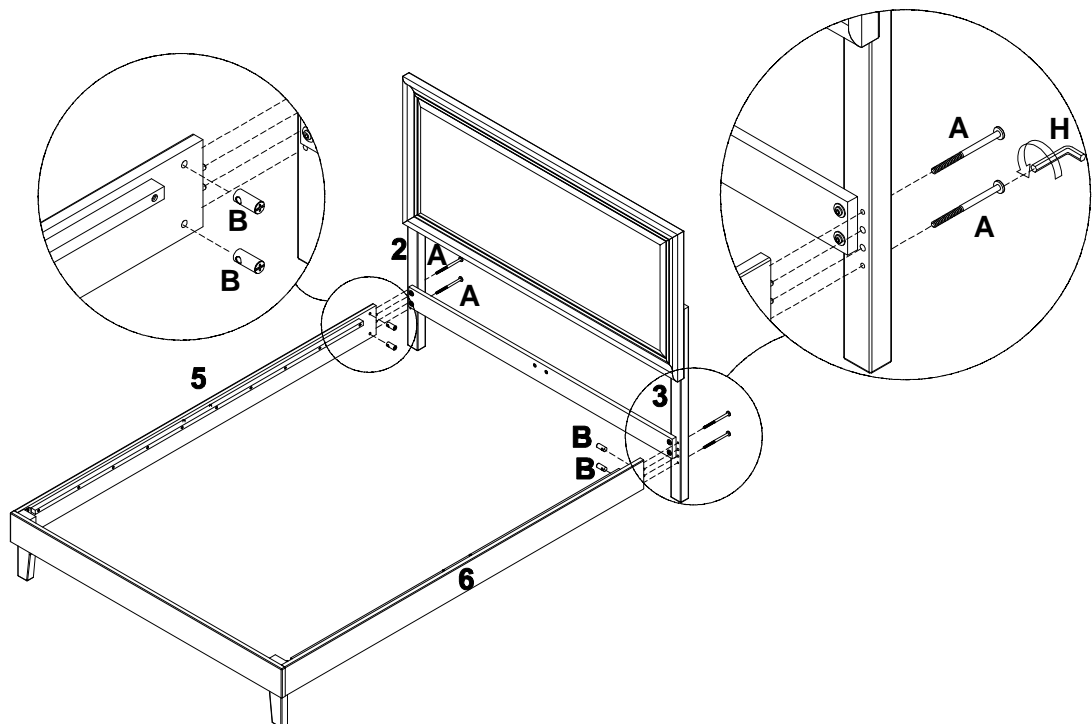

- Fit Barrel Nut (B) into the designated holes on the front edge of Left & Right Sideboard (5 & 6). Refer to Page 3 for instructions on installing Barrel Nut (B).
- Insert Screw (A) through the screw holes on Headboard Left Leg (2) to screw into the Barrel Nut on (5). Use Allen Key (H) to drive (A). Do not tighten (A) completely at this time.
- Insert Screw (A) through the screw holes on Headboard Right Leg (3) to screw into the Barrel Nut on (6). Use Allen Key (H) to drive (A). Tighten all the Screw (A) completely at this time.

## STEP 7

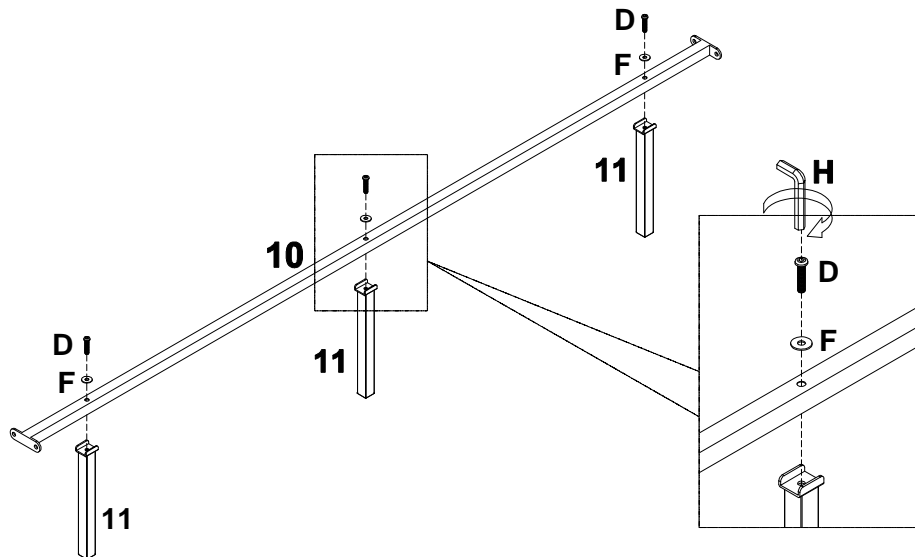

- a) Use Screw (D) fitted with Flat Washer (F) to fasten Metal Leg (11) to Center Support (10).  
Use Allen Key (H) to drive and tighten (D).

## STEP 8

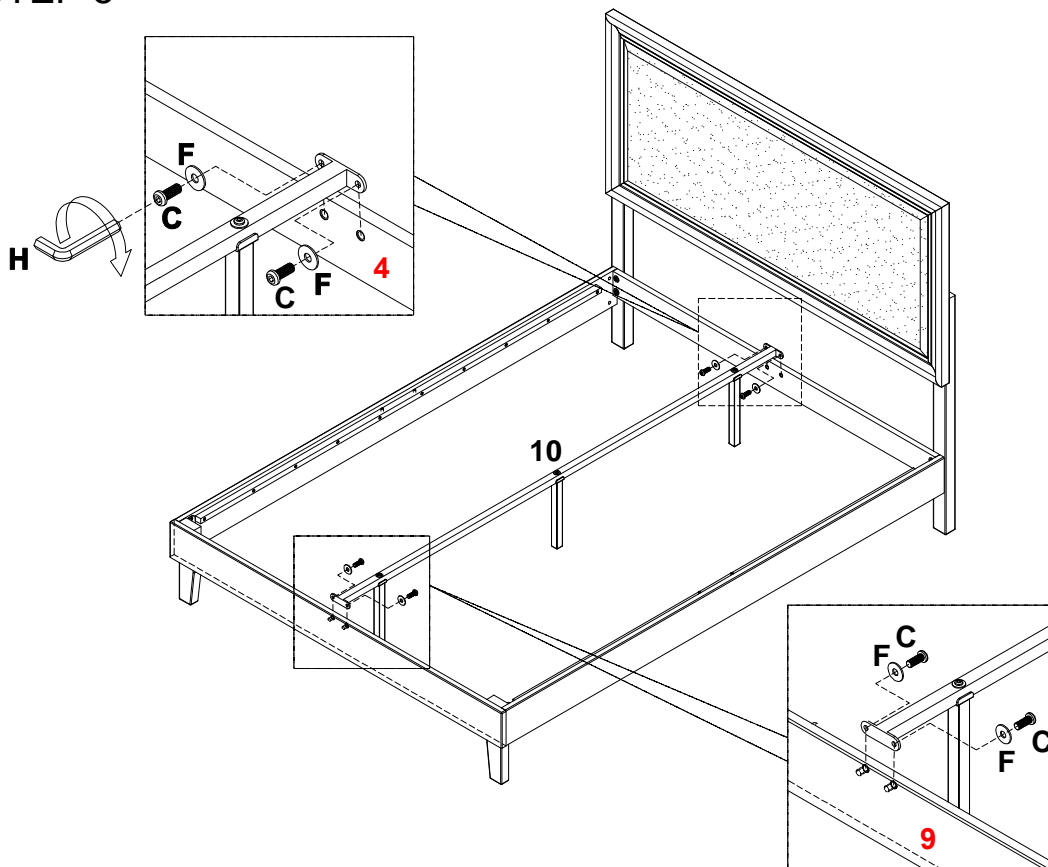

- a) Use Screw (C) fitted with Flat Washer (F) to fasten Metal Leg & Center Support assembly from STEP 7 to the center Cross Bar (4) and Footboard (9) as shown.  
Use Allen Key (H) to drive and tighten (C).

## STEP 9

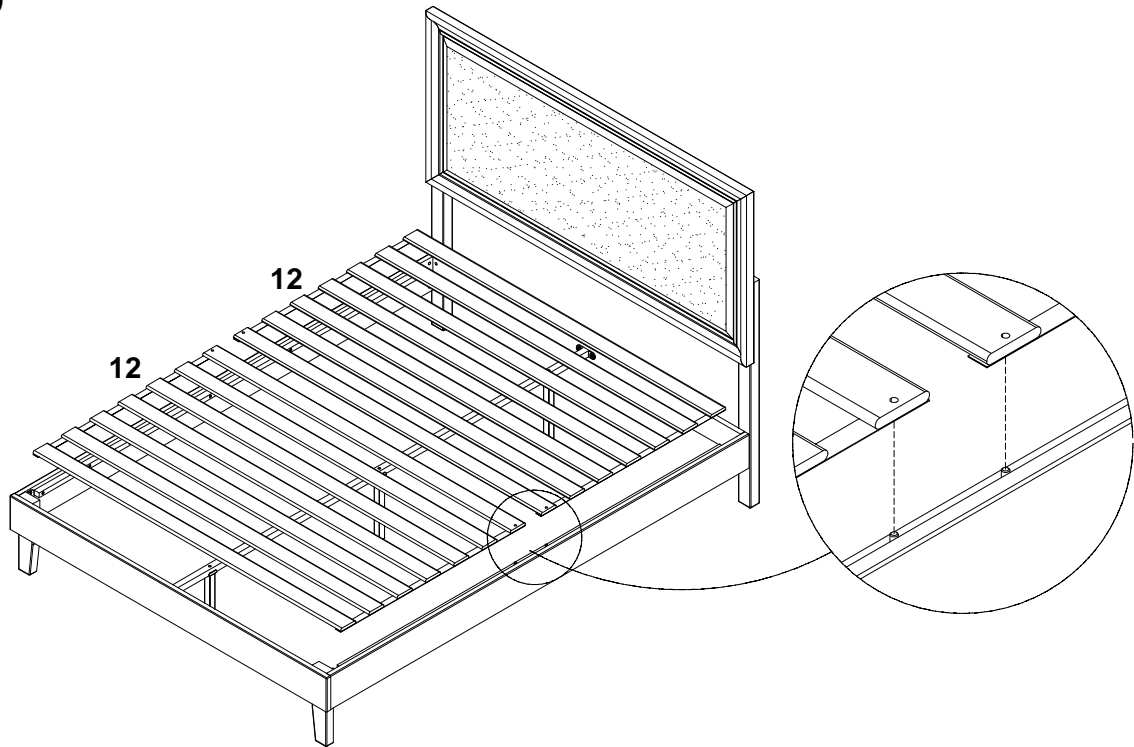

- a) Lay the 2 sets of Slat (12) on the bed frame. Check that the 2 slats with adhesive tapes face up.
  - b) Attach each slat to the "pin" on Sideboard via hole on each end of the slat - refer to enlarged drawing.
- 

## STEP 10

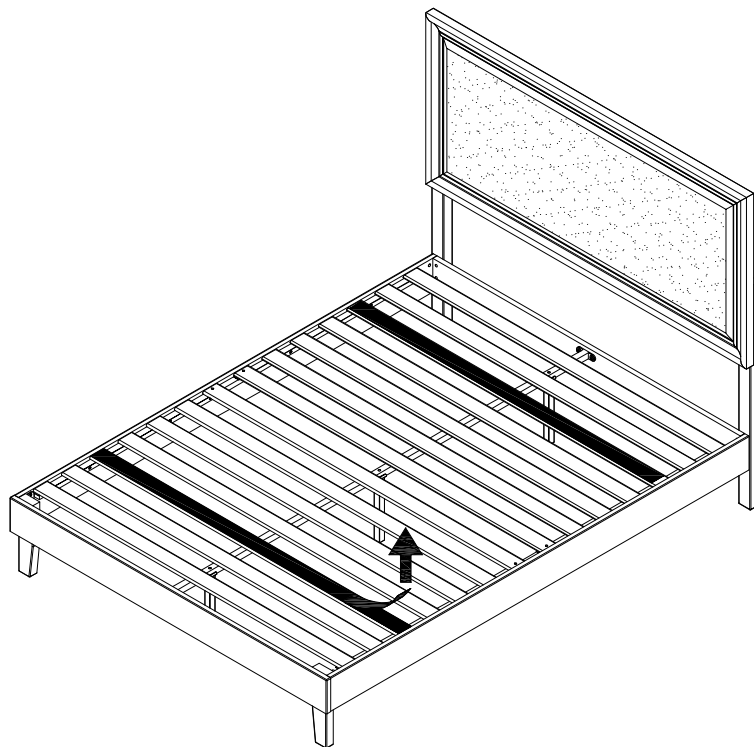

Remove the adhesive tape covering.

The assembly of the bed is complete.