

NOTICE

- * Please make sure that you have all parts indicated and they are in good condition before you begin assembly of this item. Refer to part list and hardware list below for guidance.
- * This item should be assembled on a soft surface to prevent scratching the finish during assembly.
- * This item may require periodic tightening.
- * If you are having difficulty, our friendly Customer Care team is always here to help. Please Email customersupport@safavieh.com

PREPARATION

- * Before beginning assembly of product, make sure all parts are present. Compare parts with part contents list and hardware contents list.
- * If any part is missing or damaged, do not attempt to assemble the product.
- * Estimated Assembly Time: 45 minutes.
- * Tools Required for Assembly (included): Allen Key, while Screwdriver and Hammer (Not Included).

CARE AND MAINTENANCE

WOOD CARE: Adhesive felt pads should always be applied to areas of furniture which make direct contact with flooring, said application will prevent damage to the furniture and or surfaces on which the furniture lies. Objects placed on articles of furniture should rest on nonabrasive material as to prevent damage to the wood finish. Wipe up spills immediately and avoid common hazards such as hot dishes, harsh solvents and abrasives. Cleaning should be done with a soft lint free cotton cloth dampened with water or furniture polish.



ITEM ID: COF3602A

ITEM DIMENSTION: 47.24" X 23.62" X 15.75"

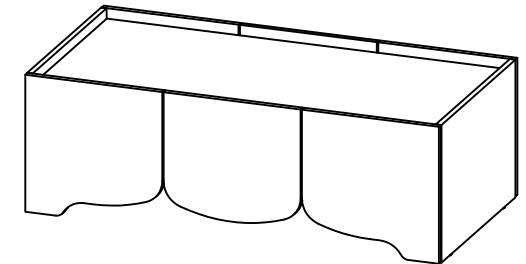





⚠WARNING⚠





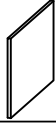
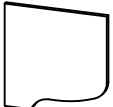

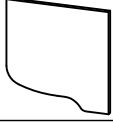

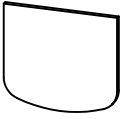
Weight Capacity - 191 LBS

Warning : Do not stand on Coffee Table

Warning : Do not over torque bolts

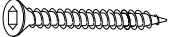
Part List and Hardware List

PIECE	DISCRIPTION	PICTURE	QTY	PIECE	DISCRIPTION	PICTURE	QTY	PIECE	DISCRIPTION	PICTURE	QTY
A	TOP PANEL		X1	D	SIDE PANEL (R)		X1	G	DOOR PANEL (L)		X2
B	BOTTOM PANEL		X1	E	MIDDLE PANEL		X1	H	DOOR PANEL (R)		X2
C	SIDE PANEL (L)		X1	F	DOOR SUPPORT		X2				

HW1	MINIFIX CAM		X20	HW4	M8 X 30MM WOOD DOWEL		X24	HW7	M3.5 X 16MM C.B SCREW		X48
HW2	MINIFIX BOLT		X20	HW5	M6 X 50MM CSK CAP WOOD SCREW		X2	HW8	5/8 PVC NAIL LEG		X4
HW3	MINIFIX CAP		X20	HW6	ALLEN KEY M4		X1	HW9	SOFT CLOSING HINGES 5/8		X8

PREPARATION

- * Before beginning assembly of product, make sure all parts are present. Compare parts with part contents list and hardware contents list.
- * If any part is missing or damaged, do not attempt to assemble the product.
- * Estimated Assembly Time: 45 minutes.
- * Tools Required for Assembly (included): Allen Key, while Screwdriver and Hammer (Not Included).

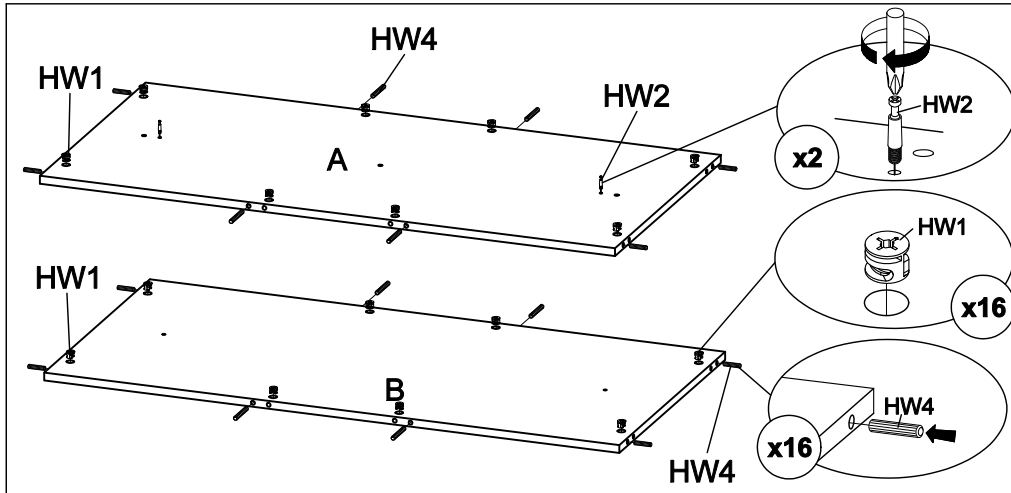

**STEP 1: INSERT HARDWARE (HW1, HW4) INTO PANEL (A, B).
INSERT HARDWARE (HW2) ONTO PANEL (A).**

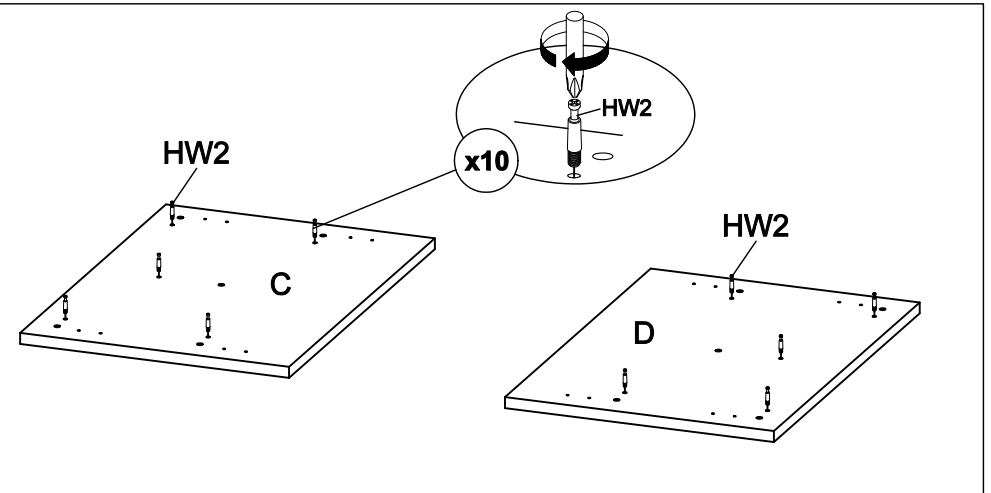

STEP 2: INSERT HARDWARE HW2 ONTO PANEL (C, D).

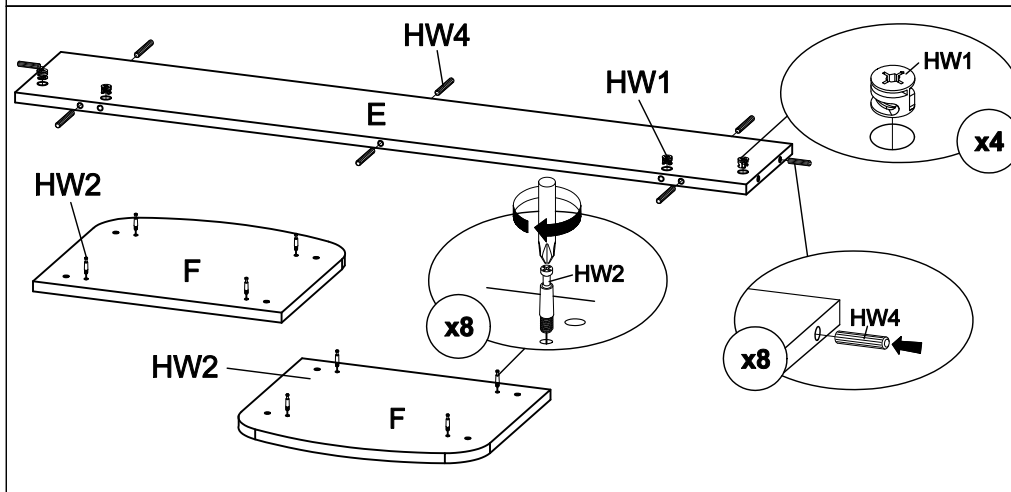

**STEP 3: INSERT HARDWARE (HW1, HW4) INTO PANEL (E).
INSERT HARDWARE (HW2) ONTO PANEL (F).**

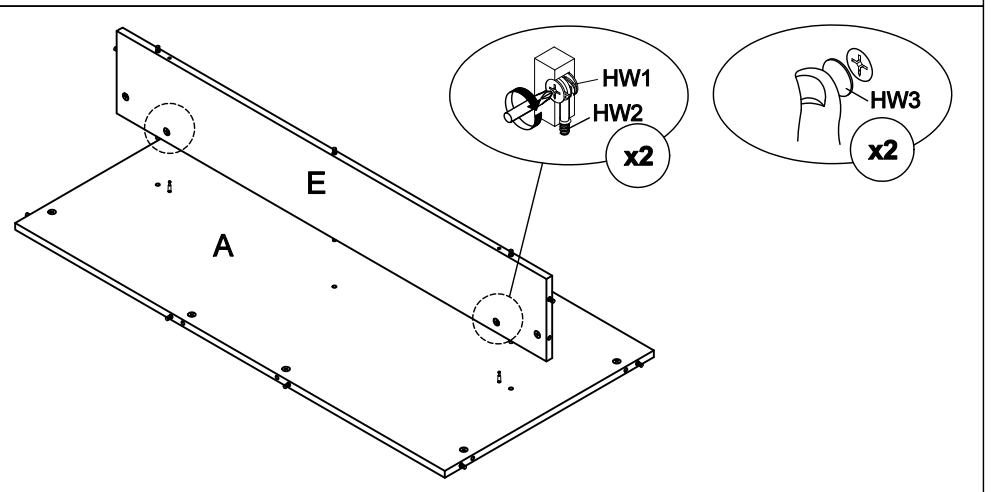

**STEP 4: ATTACH PANEL (A) TO PANEL (E). INSERT ALL HARDWARE (HW2)
INTO (HW1). ROTATE ALL (HW1) UNTIL TIGHT. APPLY (HW3)
ONTO ALL (HW1).**

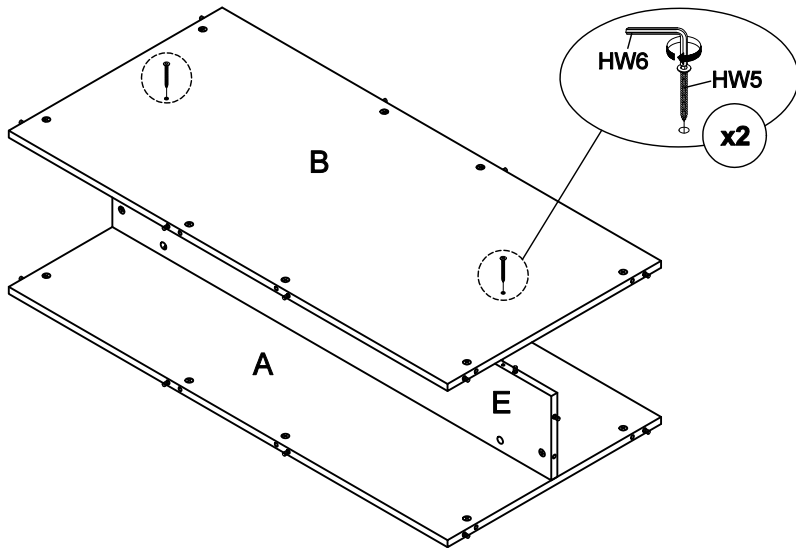

STEP 5: CONNECT PANEL (B) TO PANEL (E) BY USING HARDWARE (HW5, HW6).

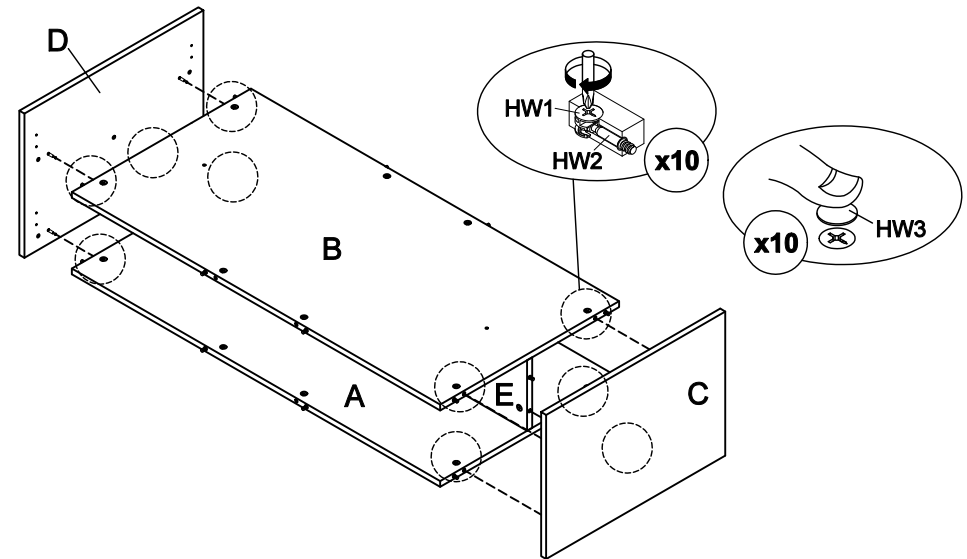

STEP 6: ATTACH PANEL (C, D) TO PANEL (A, B, E). INSERT ALL HARDWARE (HW2) INTO (HW1). ROTATE ALL (HW1) UNTIL TIGHT. APPLY (HW3) ONTO ALL (HW1).

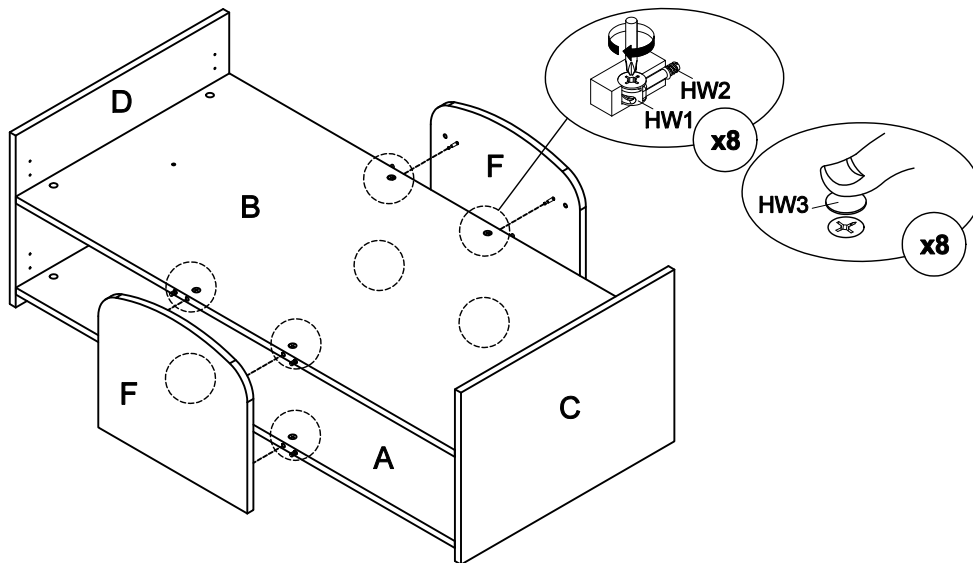

STEP 7: ATTACH PANEL (F) TO PANEL (A, B). INSERT ALL HARDWARE (HW2) INTO (HW1). ROTATE ALL (HW1) UNTIL TIGHT. APPLY (HW3) ONTO ALL (HW1).

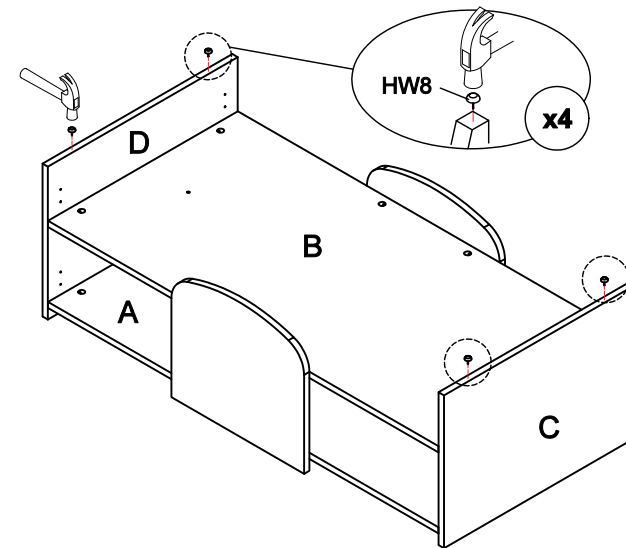

STEP 8: HIT HARDWARE (HW8) INTO BOTTOM OF THE PANEL (C, D).

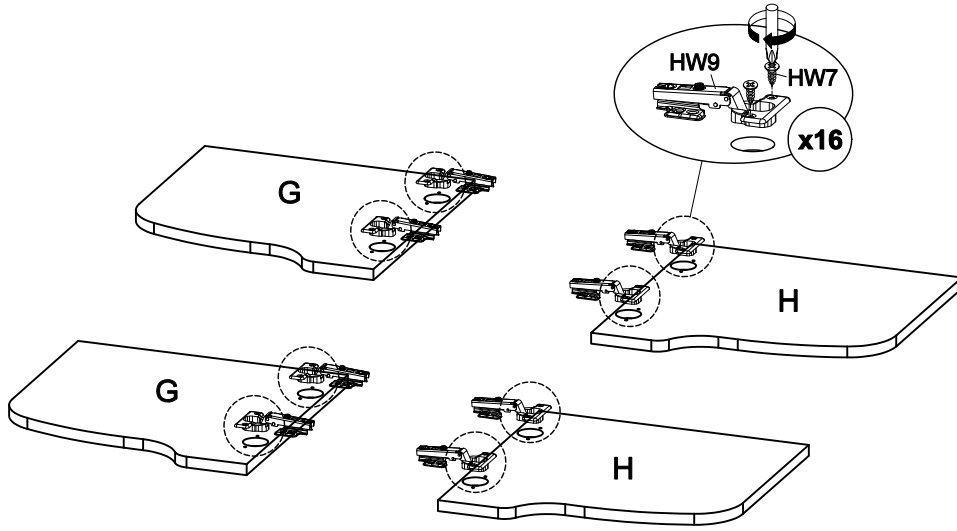

STEP 9: ATTACH HARDWARE (HW9) TO PANEL (G, H) BY USING HARDWARE (HW7).

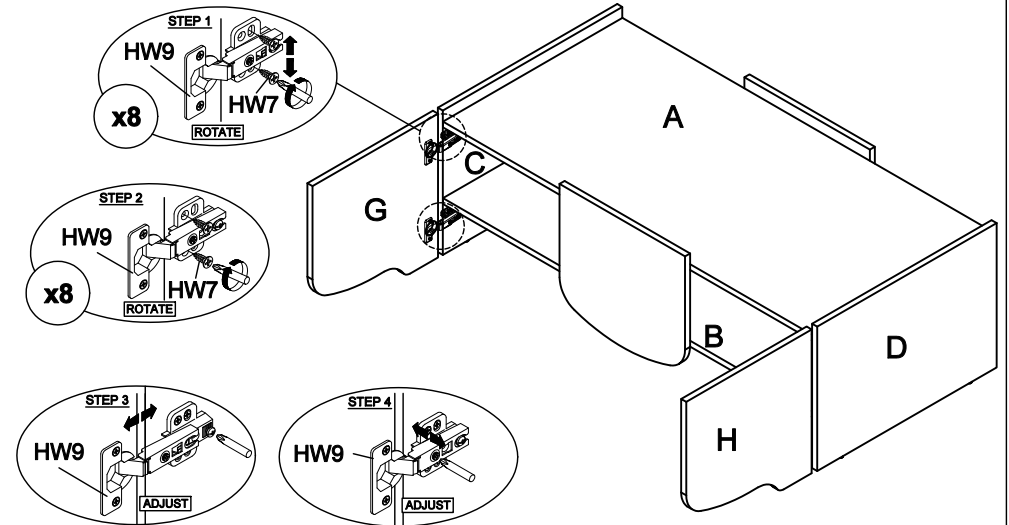

STEP 10: ATTACH HARDWARE (HW9) TO PANEL (C, D) BY USING HARDWARE (HW7). TIGHTEN OR LOOSEN THE SCREW TO ADJUST POSITION OF PANEL (G, H).

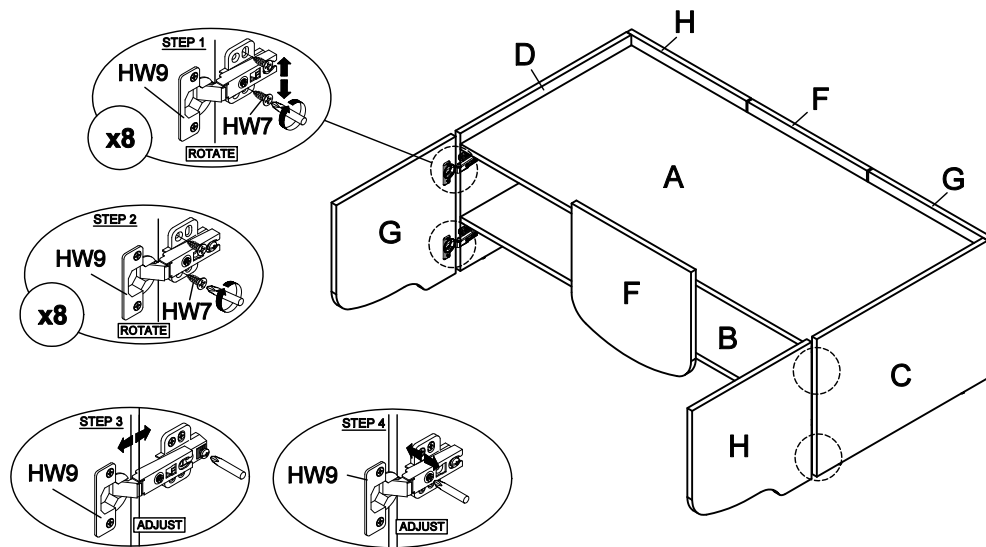

STEP 11: ATTACH HARDWARE (HW9) TO PANEL (C, D) BY USING HARDWARE (HW7). TIGHTEN OR LOOSEN THE SCREW TO ADJUST POSITION OF PANEL (G, H).