

ASSEMBLY INSTRUCTION

This set is included 3 boxes if don't receive full 3 boxes please contact our customer service team

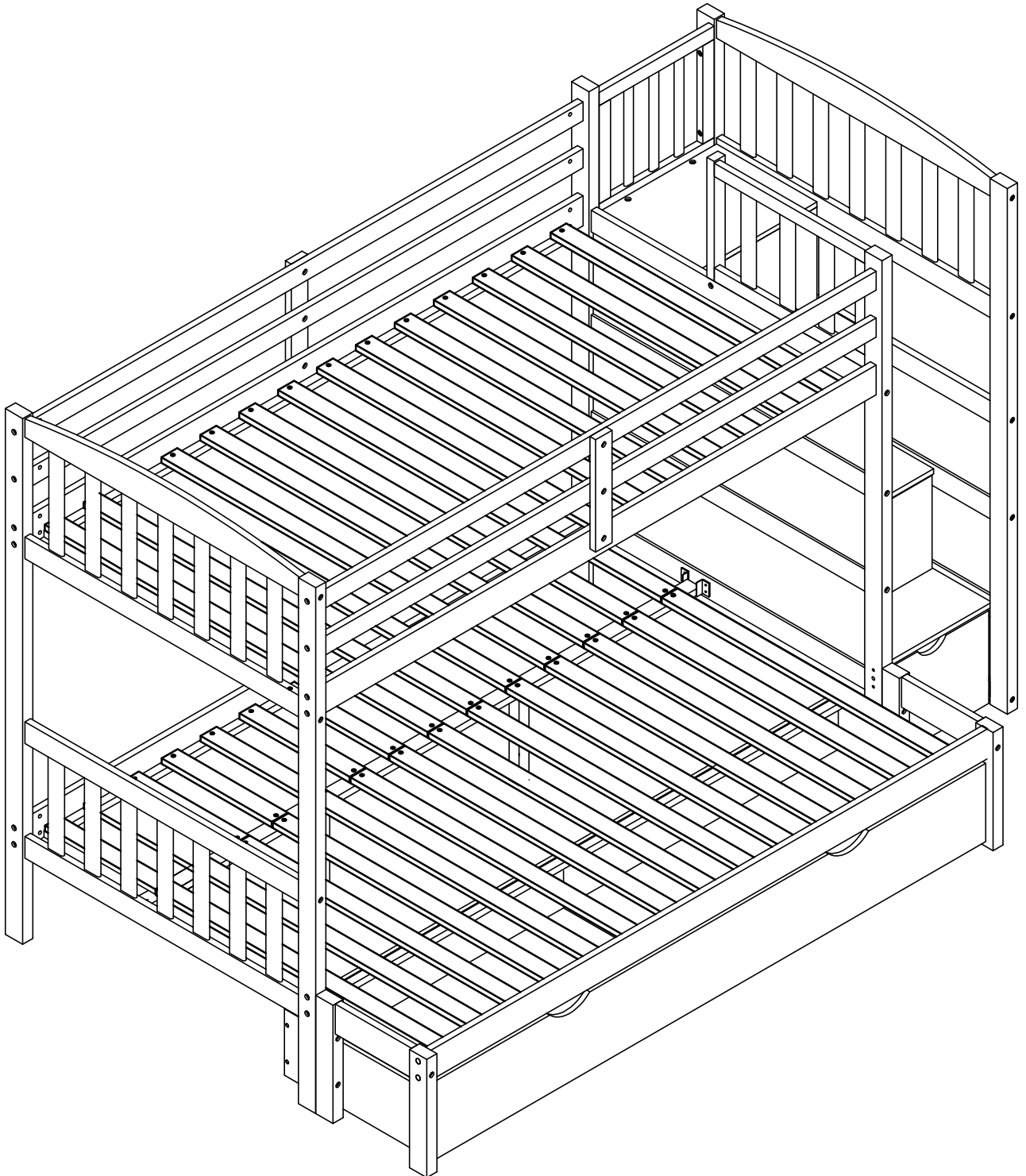

! SAFETY WARNINGS !

1. This bed is designed for use only mattress(es) meeting the following specifications on the upper bunk, and lower bunk:

Bed Type	Length	Width	Thickness
<i>Twin Standard</i>	<i>74" - 75"</i>	<i>38 1/2"</i>	<i>8" max</i>
<i>Full Standard</i>	<i>74" - 75"</i>	<i>53 1/2 "</i>	<i>8" max</i>

2. Replacement parts, including additional guardrails, may be obtained from any of our dealers
3. Follow the information on the warnings appearing on the upper bunk bed end structure and on the carton. Do not remove warning label from bed.
4. Always use the recommended size mattresses or mattress supports, or both, to help prevent the likelihood of entrapment or falls.
5. Surface of the mattress must be at least 5" (127 mm) below the upper edge of guardrails.
6. Do not allow children under 6 years of age to use the upper bunk.
7. Periodically check and ensure that the guardrail, ladder, and other components are in their proper position, free from damage, and that all connectors are tight.
8. Do not allow horseplay on or under the bed and prohibit jumping on the bed
9. Always use the ladder for entering and leaving the upper bunk.
10. Do not use substitute parts. Contact the manufacturer or dealer for replacement parts.
11. Use of a night light may provided added safety precaution for a child using the upper bunk.
12. Always use guardrails on both long sides of the upper bunk. If the bunk bed will be placed next to the wall, the guardrail that runs the full length of the bed should be placed against the wall to prevent entrapment between the bed and wall.
13. The use of water or sleep flotation mattresses is prohibited.
14. **STRANGULATION HAZARD** – Never attach or hang items to any part of the bunk bed that are not designed for use with the bed; for example, but not limited to, hook, belts and jump ropes.
15. Keep these instructions for future reference

ASSEMBLY INSTRUCTION

This Bed could be used as Twin Over Full (Option1) or Twin Over Twin (Option 2) as your decide. If you want to use Twin Over Twin bed please follow from Step 23

OPTION 1

TWIN OVER FULL BED

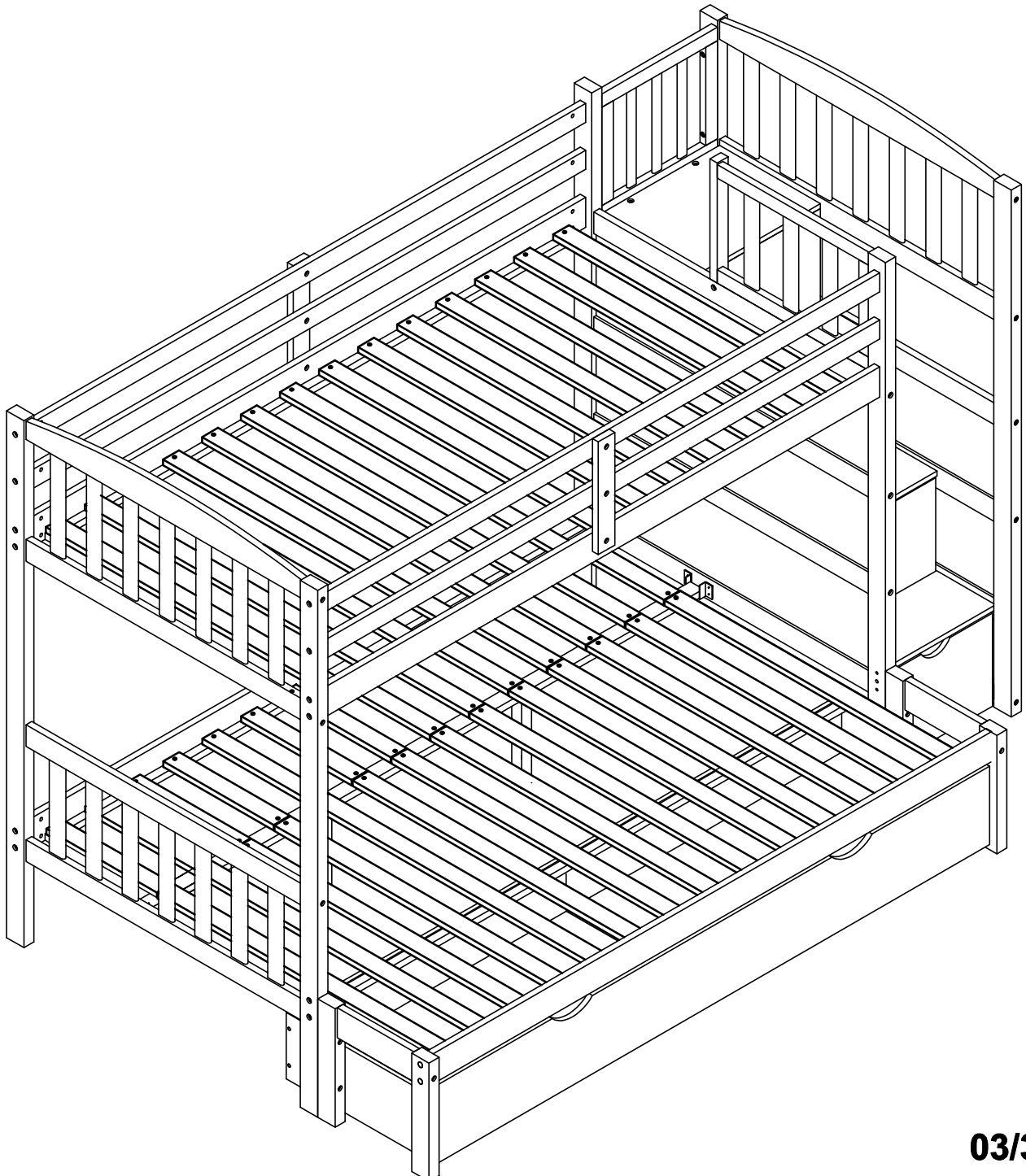

ASSEMBLY INSTRUCTION





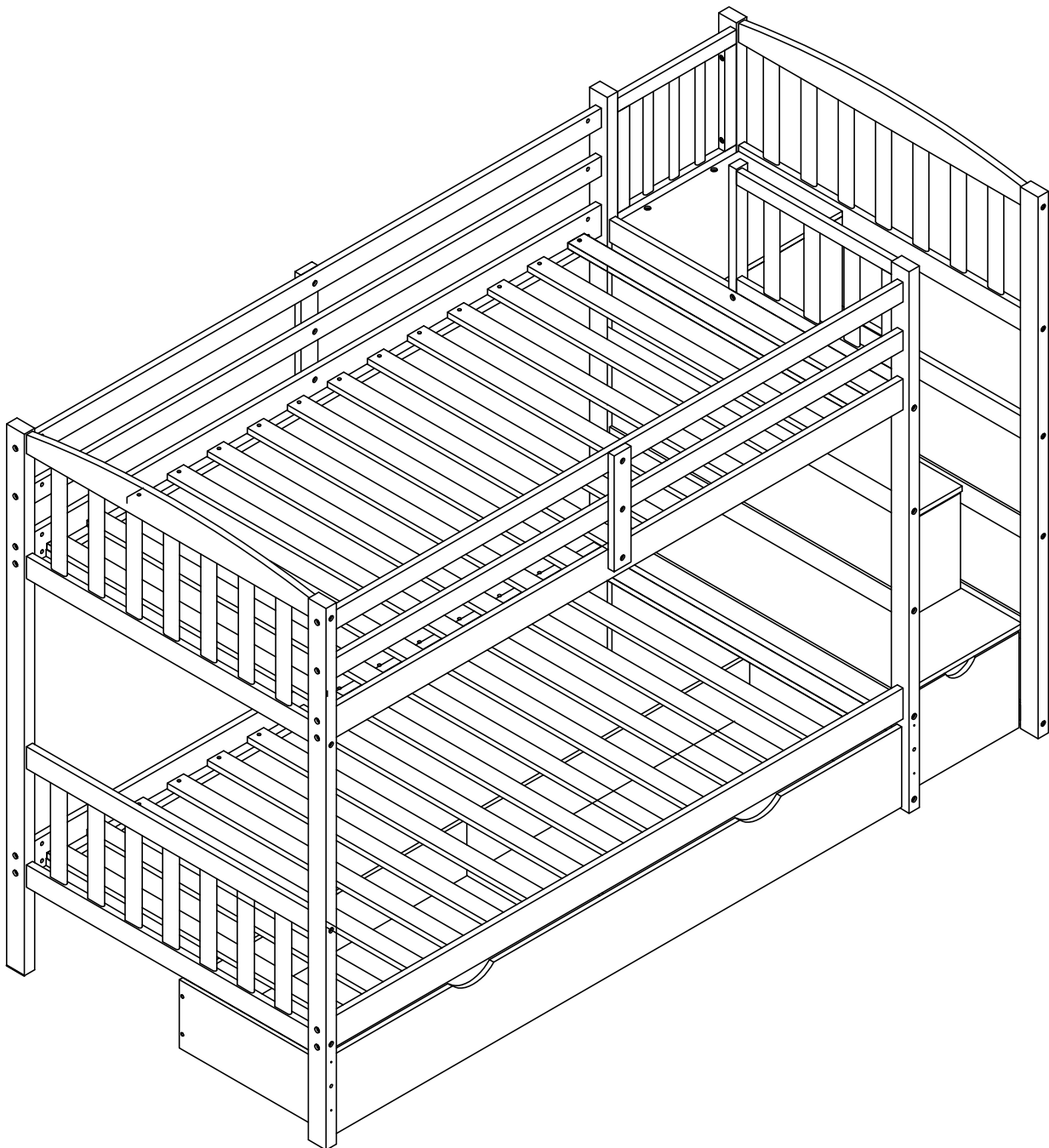

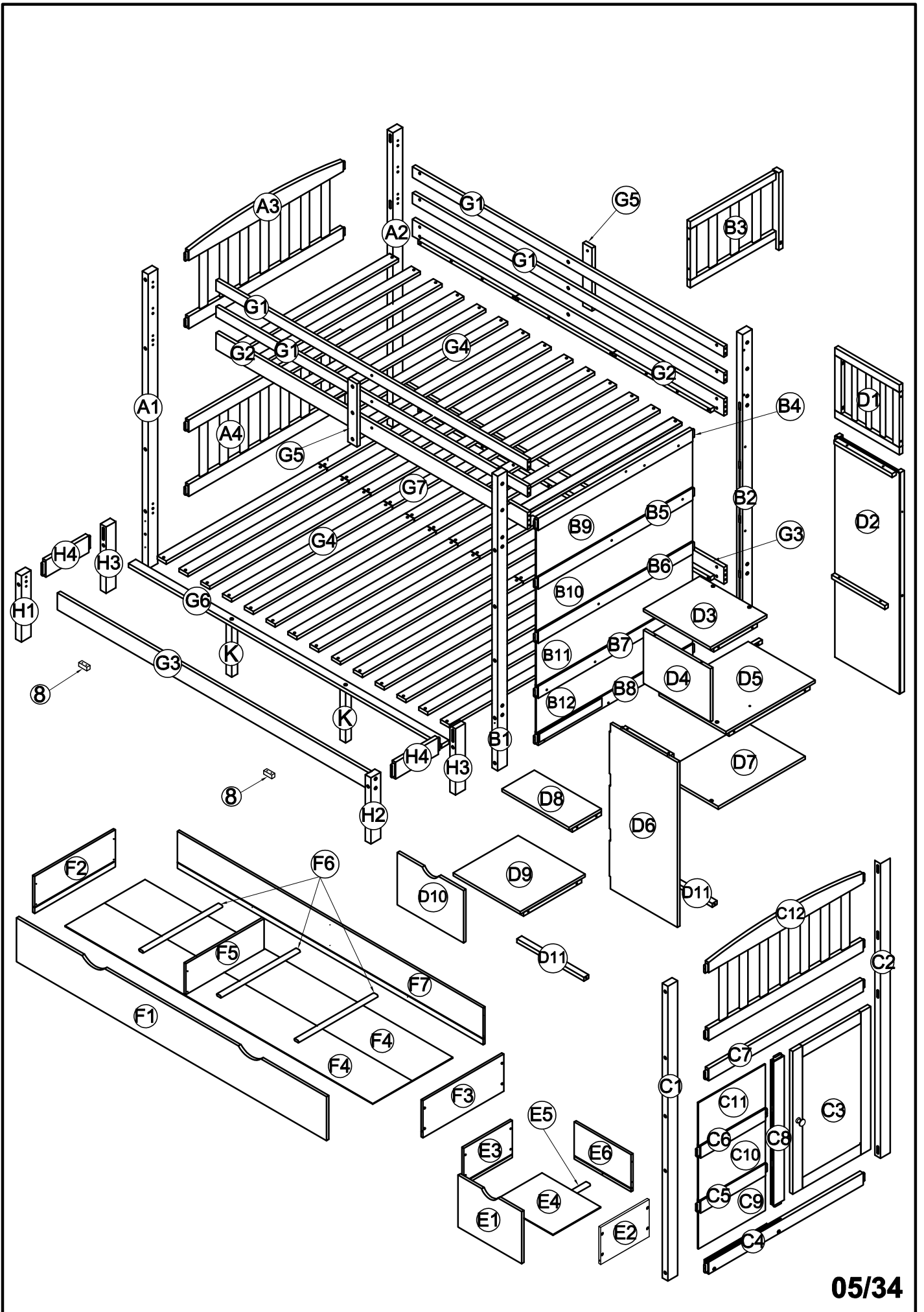

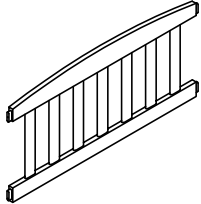
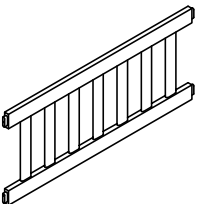
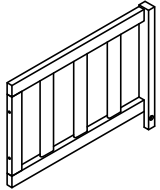
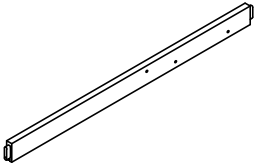
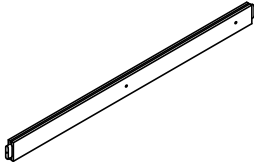
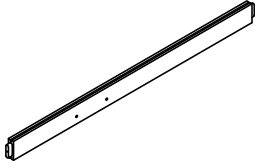
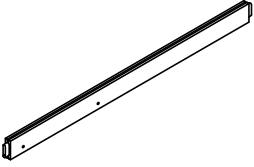
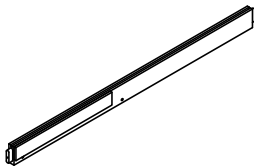
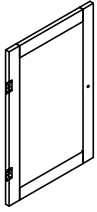

OPTION 2

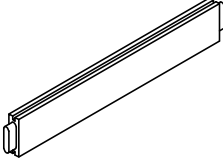
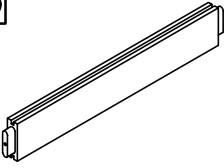
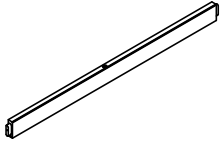
TWIN OVER TWIN BED

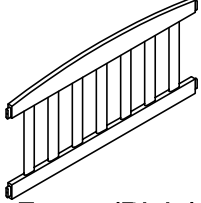

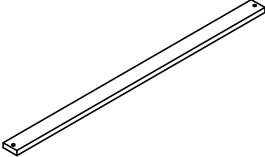
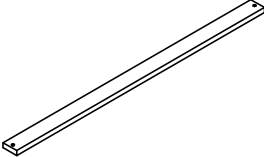

Part List & Hardware List (Box 1)

<p>A3</p>  <p>Side Frame - 1pcs</p>	<p>A4</p>  <p>Side Frame - 1pcs</p>	<p>B3</p>  <p>Side Frame (Center) - 1pcs</p>
<p>B4</p>  <p>Wood Bar (Middle Frame)- 1pcs</p>	<p>B5</p>  <p>Wood Bar (Middle Frame)- 1pcs</p>	<p>B6</p>  <p>Wood Bar (Middle Frame)- 1pcs</p>
<p>B7</p>  <p>Wood Bar (Middle Frame)- 1pcs</p>	<p>B8</p>  <p>Wood Bar (Middle Frame)- 1pcs</p>	<p>C3</p>  <p>Door-1pcs</p>
<p>C4</p>  <p>Wood Bar (Right) - 1pcs</p>	<p>C5</p>  <p>Wood Bar (Right) - 1pcs</p>	<p>C6</p>  <p>Wood Bar (Right) - 1pcs</p>
<p>C7</p>  <p>Wood Bar (Right) - 1pcs</p>	<p>C8</p>  <p>Wood Bar (Right) - 1pcs</p>	<p>C12</p>  <p>SideFrame (Right) - 1pcs</p>
<p>D1</p>  <p>Back Frame- 1pcs</p>	<p>G4</p>  <p>Slats - 28pcs</p>	<p>G7</p>  <p>Short Slats -14pcs</p>
<p>H1</p>  <p>Front Leg(left)-1pcs</p>	<p>H2</p>  <p>Front Leg(Right)-1pcs</p>	<p>H3</p>  <p>Back Leg-2pcs</p>

Part List & Hardware List (Box 1-

H4

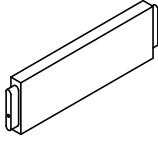

Side Rail-2pcs

K







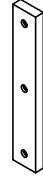

Support Legs-2pcs

G5



Rail - 2pcs

Part List(

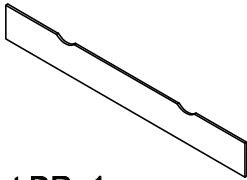
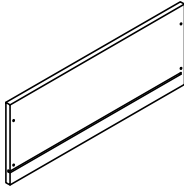
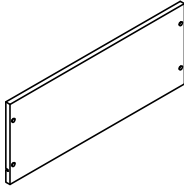
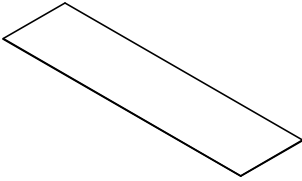
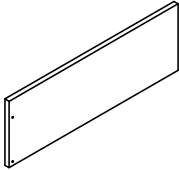
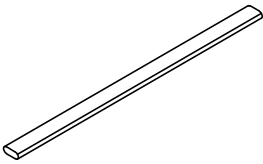
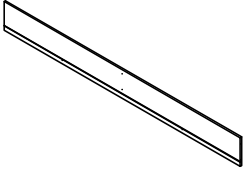
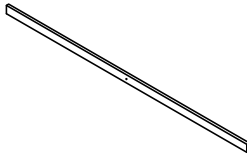
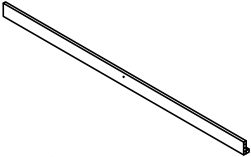
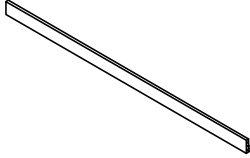
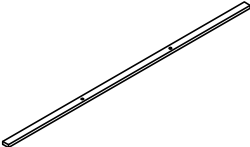
<p>A1</p>  <p>Front Leg (Left) - 1pcs</p>	<p>A2</p>  <p>Black Leg (Left) - 1pcs</p>	<p>B1</p>  <p>Front Leg (Center) - 1pcs</p>
<p>B2</p>  <p>Back Leg (Center) - 1pcs</p>	<p>C1</p>  <p>Front Leg (Right) - 1pcs</p>	<p>C2</p>  <p>Front Leg (Right) - 1pcs</p>
<p>F1</p>  <p>Front DR - 1pcs</p>	<p>F2</p>  <p>Side DR - 1pcs</p>	<p>F3</p>  <p>Side DR - 1pcs</p>
<p>F4</p>  <p>Bottom DR - 2pcs</p>	<p>F5</p>  <p>Center DR - 1pcs</p>	<p>F6</p>  <p>Bottom DR - 3pcs</p>
<p>F7</p>  <p>Back DR - 1pcs</p>	<p>G1</p>  <p>Guardrail - 4pcs</p>	<p>G2</p>  <p>Rail - 2pcs</p>
<p>G3</p>  <p>Rail - 2pcs</p>	<p>G6</p>  <p>Bottom Support Salats - 1pcs</p>	

Part List(

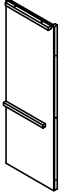
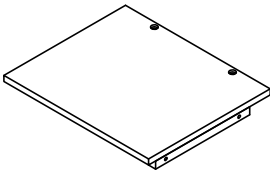
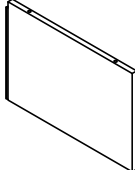
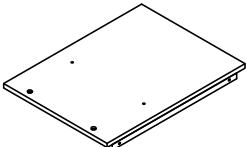
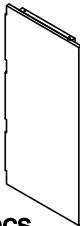
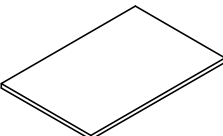
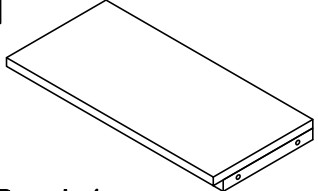
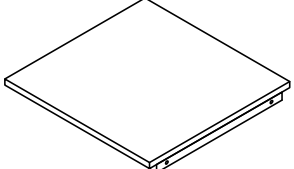
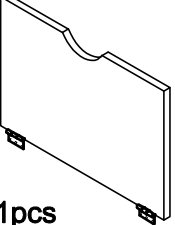
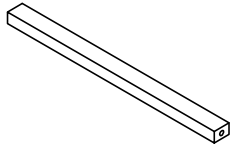
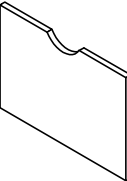
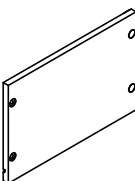
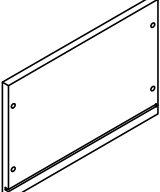
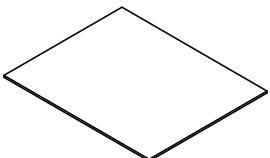
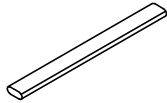
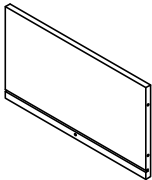
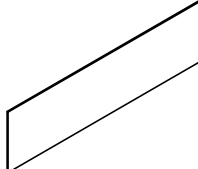
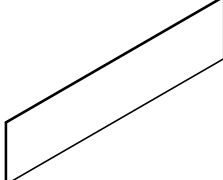
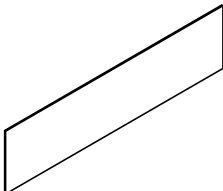
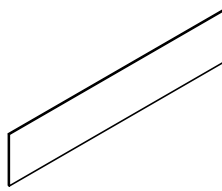
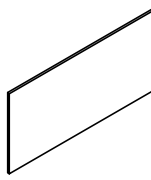
<p>D2</p>  <p>Back Frame- 1pcs</p>	<p>D3</p>  <p>Panel- 1pcs</p>	<p>D4</p>  <p>Panel- 1pcs</p>
<p>D5</p>  <p>Panel- 1pcs</p>	<p>D6</p>  <p>Panel- 1pcs</p>	<p>D7</p>  <p>Panel- 1pcs</p>
<p>D8</p>  <p>Panel- 1pcs</p>	<p>D9</p>  <p>Panel- 1pcs</p>	<p>D10</p>  <p>Panel- 1pcs</p>
<p>D11</p>  <p>Front Rail -2pcs</p>	<p>E1</p>  <p>Front DR -1pcs</p>	<p>E2</p>  <p>Side DR -1pcs</p>
<p>E3</p>  <p>Side DR -1pcs</p>	<p>E4</p>  <p>Bottom DR -1pcs</p>	<p>E5</p>  <p>Bottom DR -1pcs</p>
<p>E6</p>  <p>Back DR -1pcs</p>	<p>B9</p>  <p>Side Panel (Middle Frame) - 1pcs</p>	<p>B10</p>  <p>Side Panel (Middle Frame) - 1pcs</p>
<p>B11</p>  <p>Side Panel (Middle Frame) - 1pcs</p>	<p>B12</p>  <p>Side Panel (Middle Frame) - 1pcs</p>	<p>C9</p>  <p>Side Panel (Right) - 1pcs</p>

Part List(

C10

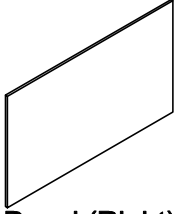





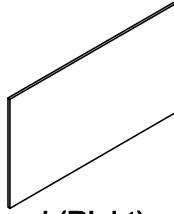







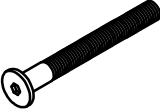

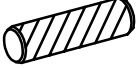
Side Panel (Right) - 1pcs

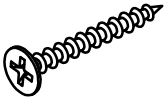
C11

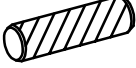

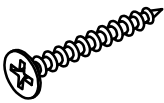
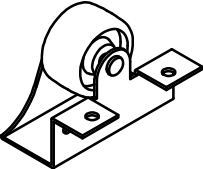
Side Panel (Right) - 1pcs

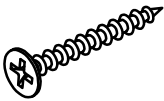
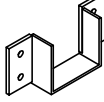
Hardware List

<p>1</p>  <p>Screws 1/4" x80 (34pcs)</p>	<p>1.1</p>  <p>Screws 1/4" x100 (4pcs)</p>	<p>2</p>  <p>Ø1/4" x 25 mm Hex-Head bolts 7pcs</p>
<p>2.1</p>  <p>Ø1/4" x 50 mm Hex-Head bolts 6pcs</p>	<p>3</p>  <p>Ø1/4" x 15 mm Canopy head though - 7pcs</p>	<p>4</p>  <p>Ø10 x 40 mm Wood dowel 18pcs</p>
<p>5</p>  <p>Ø1/4" x 80 mm Hex-Head bolts 24pcs</p>	<p>6</p>  <p>Ø1/4" x 13 mm Horizontal-hole bolts 24pcs</p>	<p>7</p>  <p>M4 x 30 mm Wood Screws 112pcs</p>
<p>8</p>  <p>Drawer Stopper- 2pcs</p>	<p>9</p>  <p>Ø1/4" x 30 mm Hex-Head bolts 32pcs</p>	<p>10</p>  <p>Ø8 x 30 mm Wood dowel 6pcs</p>
<p>11</p>  <p>Ø1/6" x 25 mm Hex-Head bolts 1pcs</p>	<p>12</p>  <p>Handle Wood 1pcs</p>	<p>13</p>  <p>M3 x 12 mm Wood Screws 24pcs</p>
<p>14</p>  <p>Wheels 4pcs</p>	<p>15</p>  <p>Allen Key 1pc</p>	<p>16</p>  <p>M4 x 20 mm Wood Screws 8pcs</p>
<p>17</p>  <p>Bracket Steel 2pcs</p>	<p>18</p>  <p>Ø1/4" x 35 mm Hex-Head bolts 2pcs</p>	

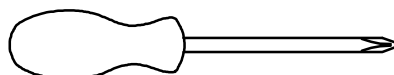

Assembly Tools Required (Not Included)

STEP 1: Following below illustration Assembly Headboard. Using hardware

#1 connect A1 and A2 legs with A3 Frame & A4 Frame to complete Headboard

1



4x2(pcs)

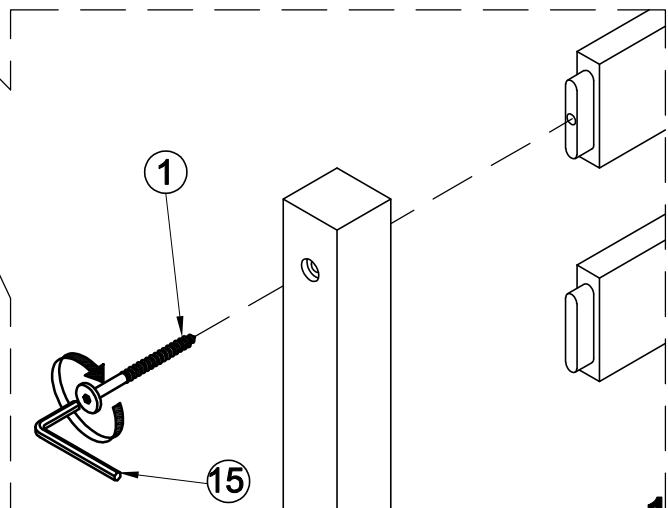
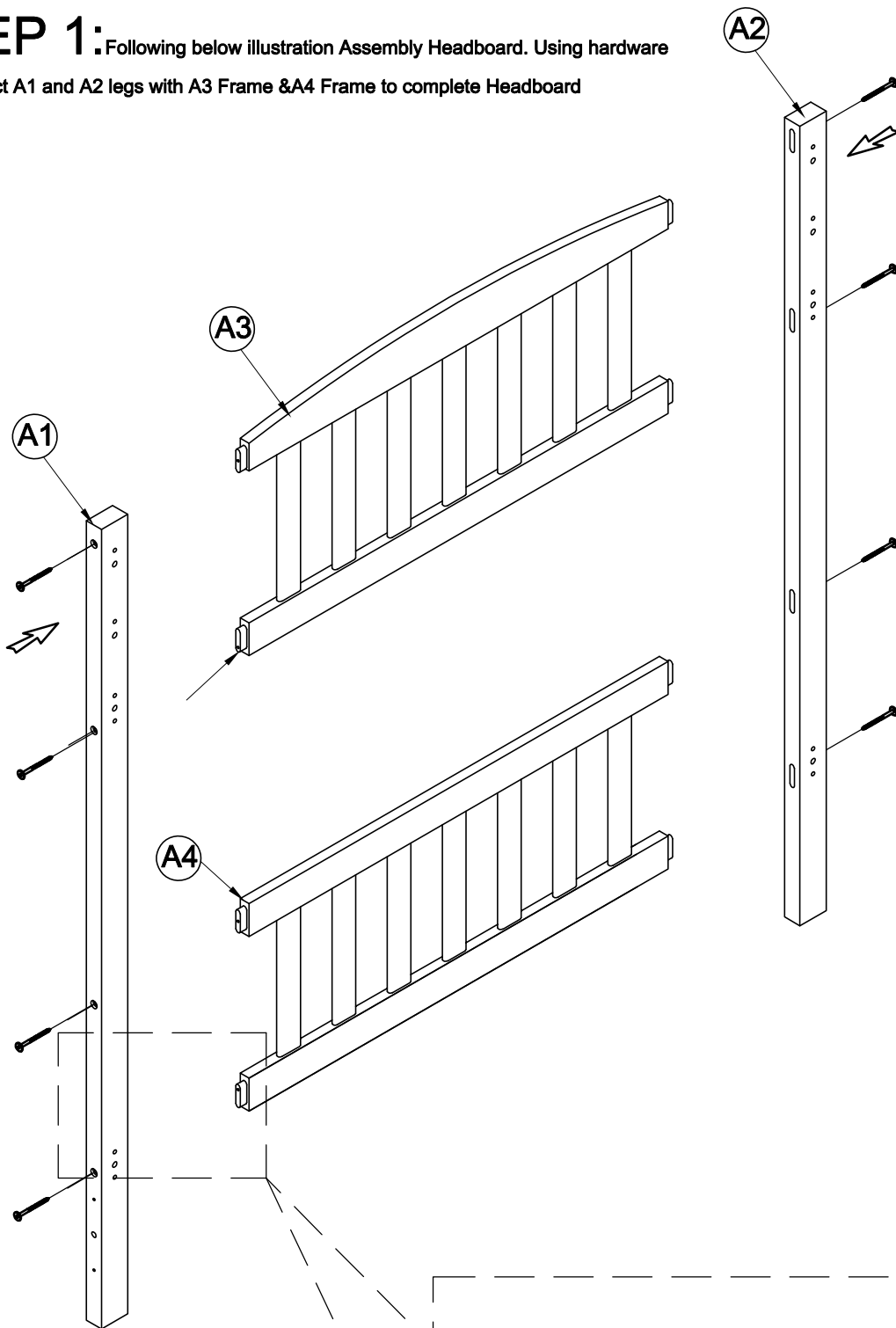

STEP 2-1: Following below illustration Assembly Footboard. Using hardware #1 connect B1 and B2 legs with B4,B5,B6,B7,B8 Wood Bar &B9,B10,B11,B12

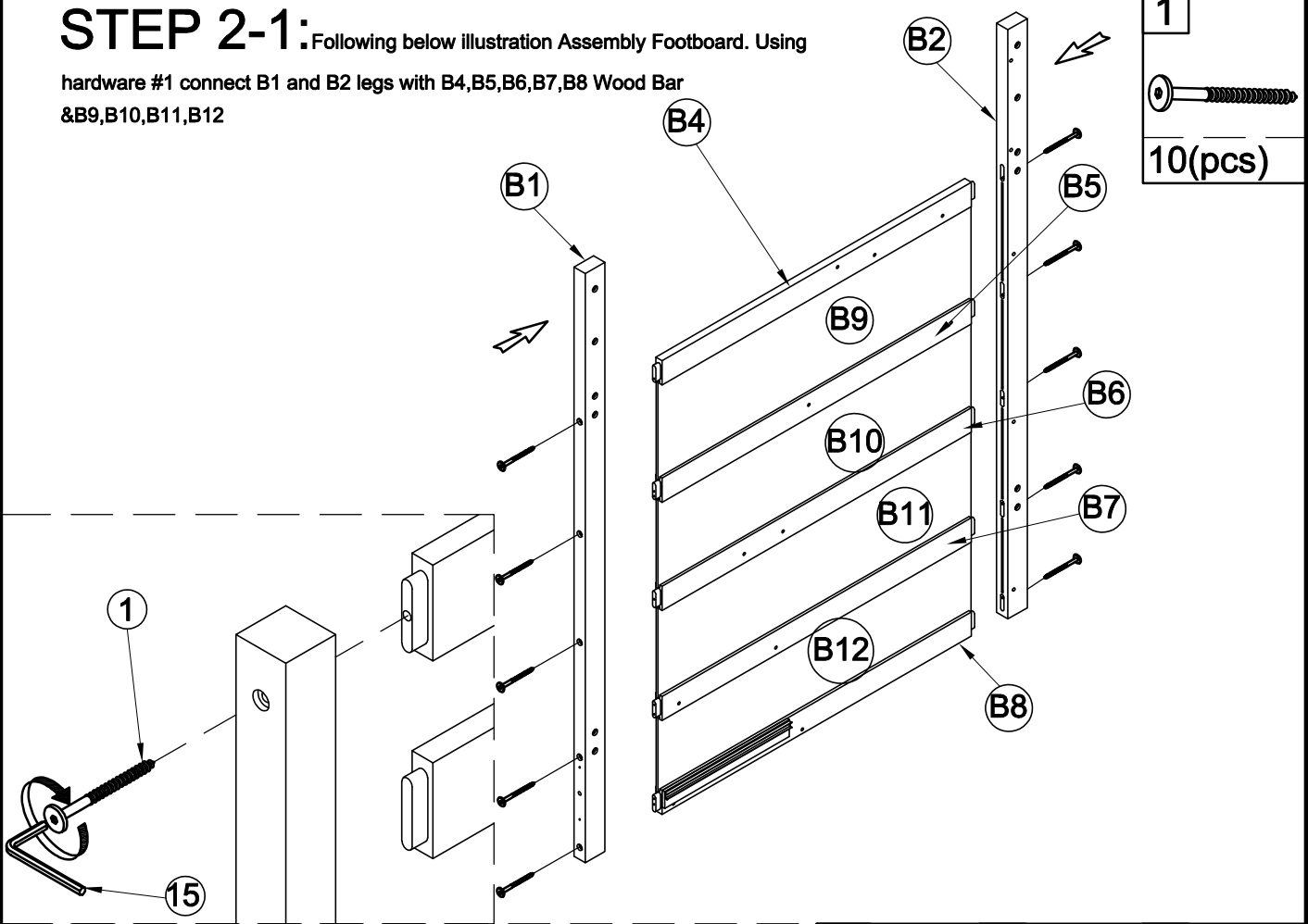

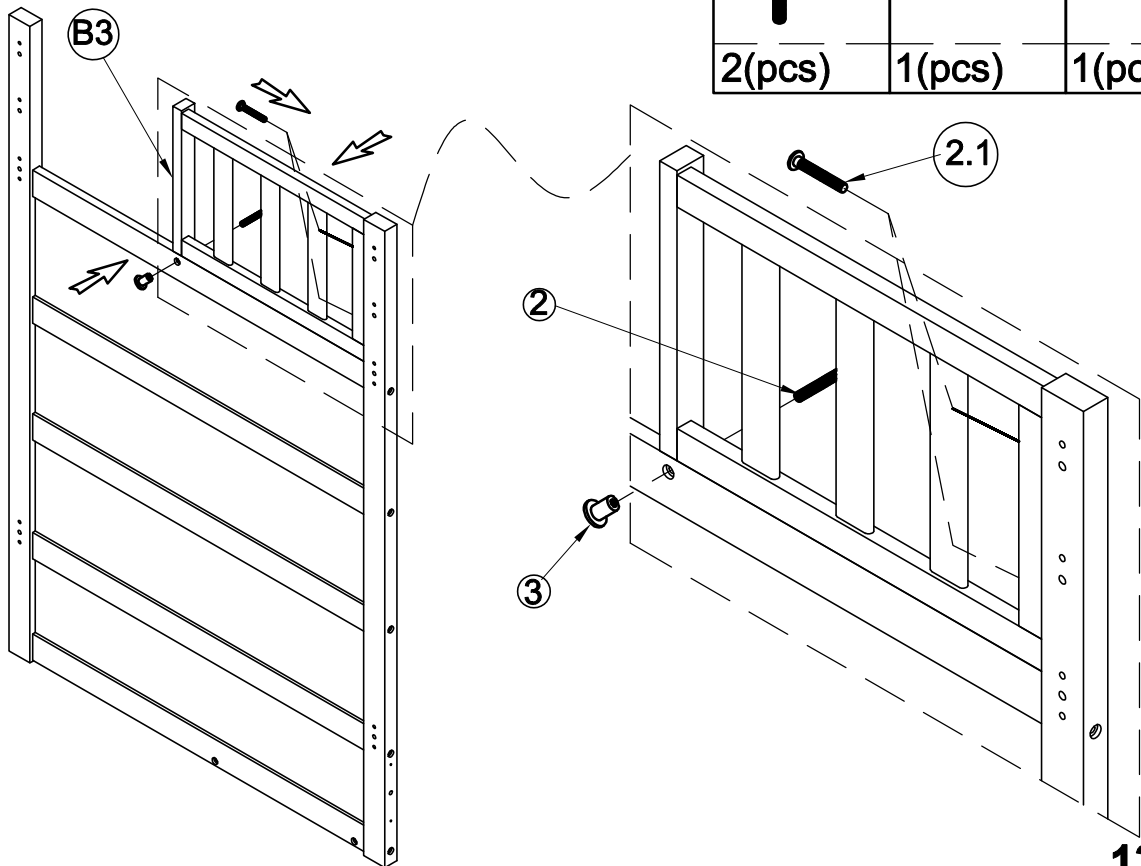

STEP 2-2: Following below illustration Assembly Footboard. Using hardware #2,#2.1,#3 connect Frame(completed on Step 2-1) with B3 Frame to complete Footboard

2.1	3	2
2(pcs)	1(pcs)	1(pcs)

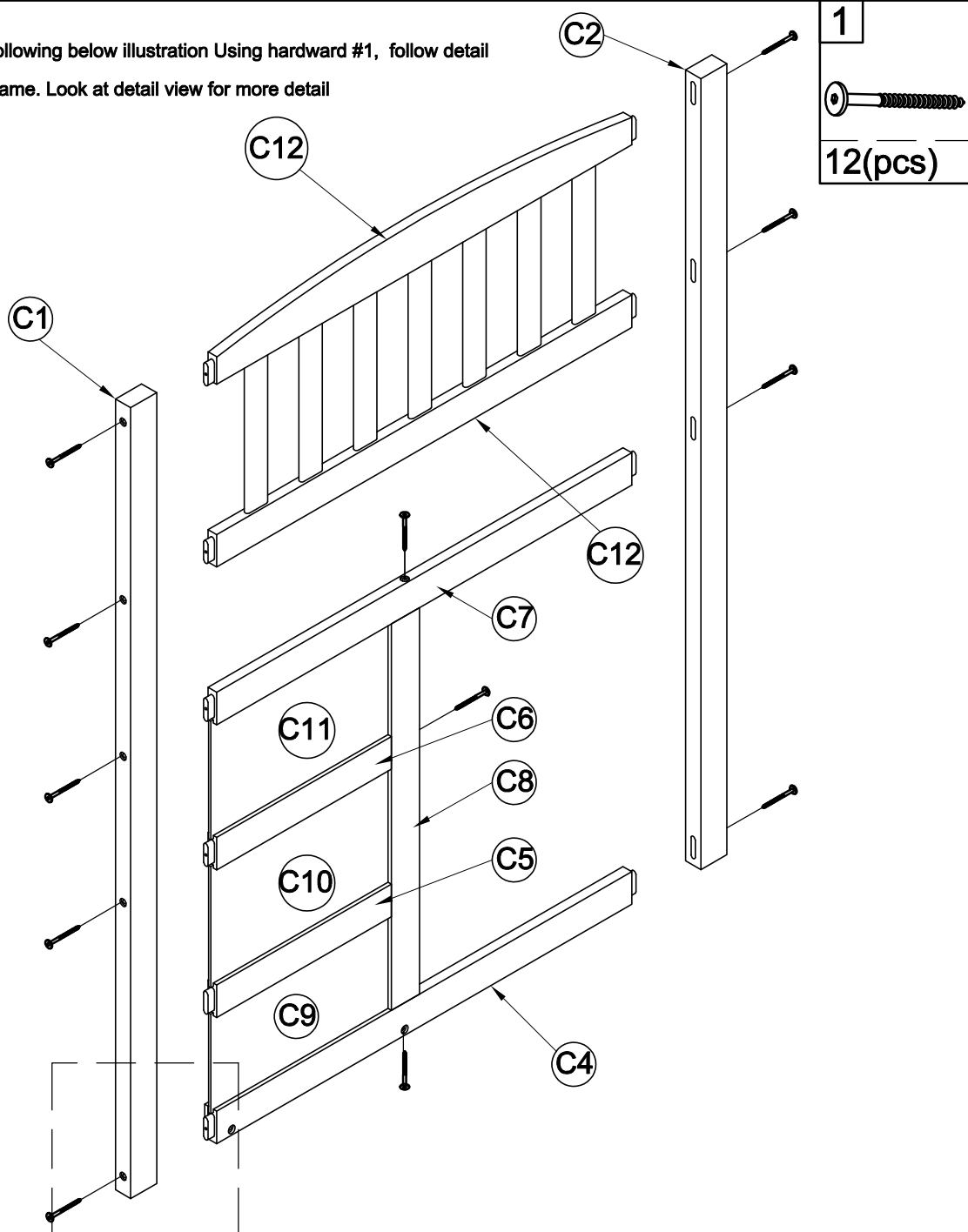

STEP 3: Following below illustration Using hardward #1, follow detail view to Assembly Right Frame. Look at detail view for more detail

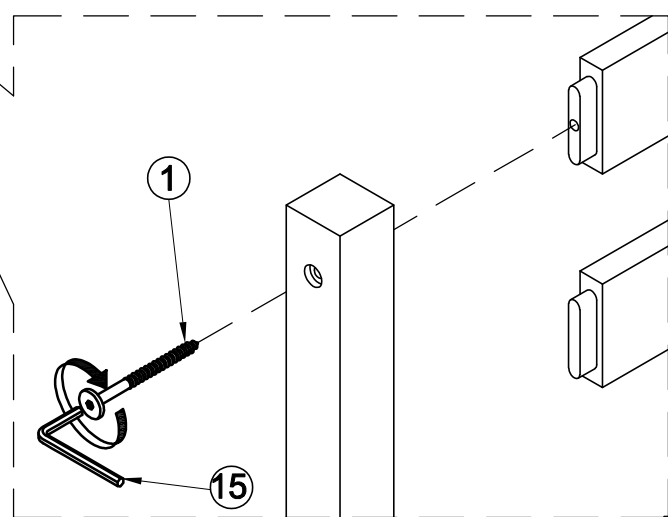

1

12(pcs)



STEP 4: Assembly Extension Kit. Follow the illustration

1



2x2(pcs)

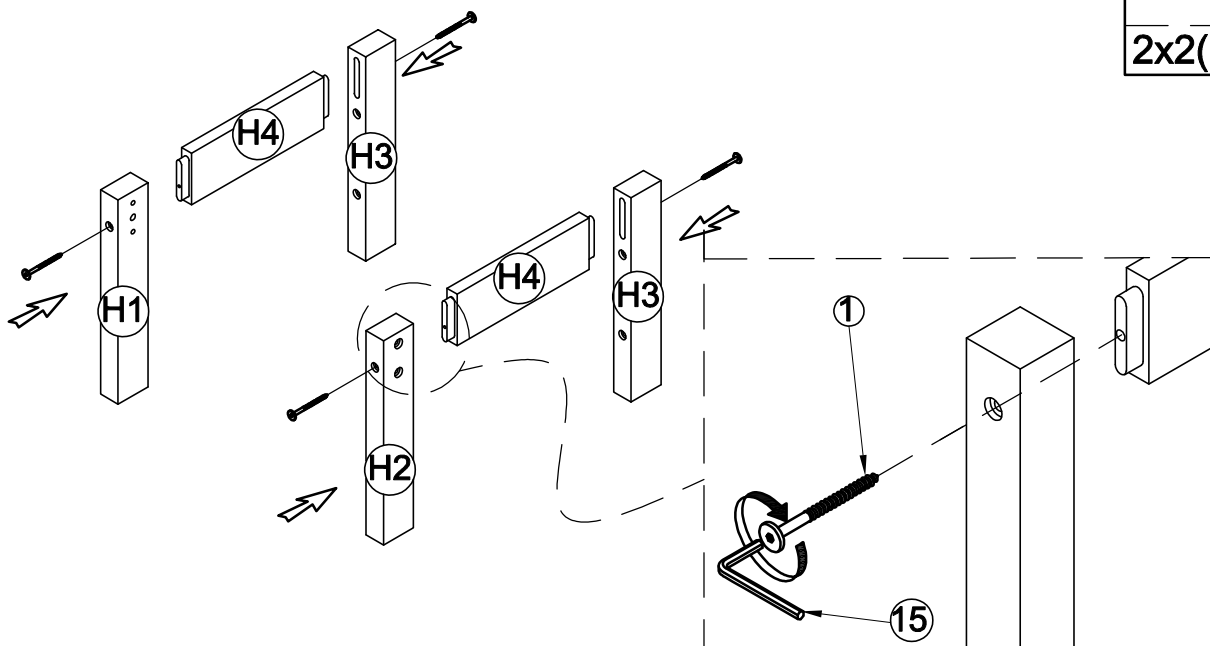

STEP 5: Following the illustration

.Connect Extension With Frame.
Look at detail view for more detail

4

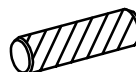

2(pcs)

1.1



4(pcs)

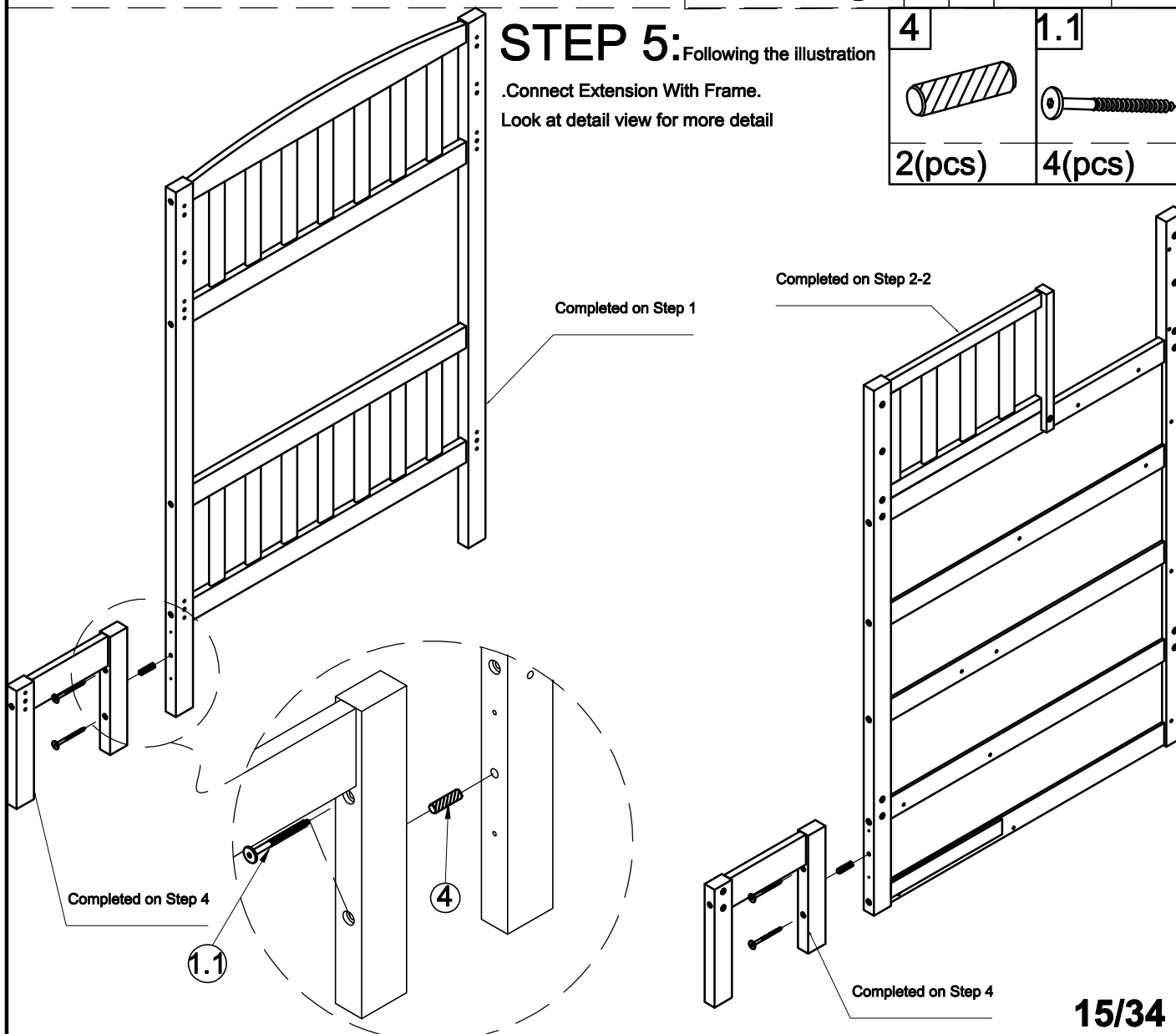

STEP 6:

Following below illustration Using hardware #5, #6 and dowel #4 follow detail view to Assembly Headboard and Footboard and Extension Kit with siderail G2(2),siderail G3(2) & Guardrail G1(4). Look at detail view for more detail

6



24(pcs)

5

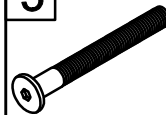

24(pcs)

4

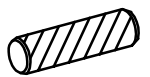

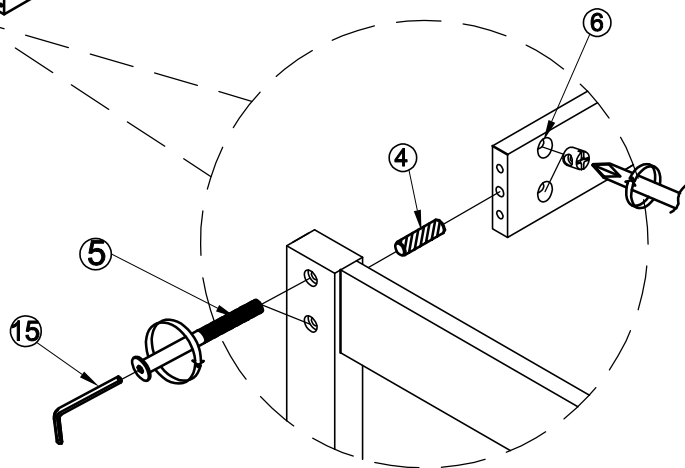
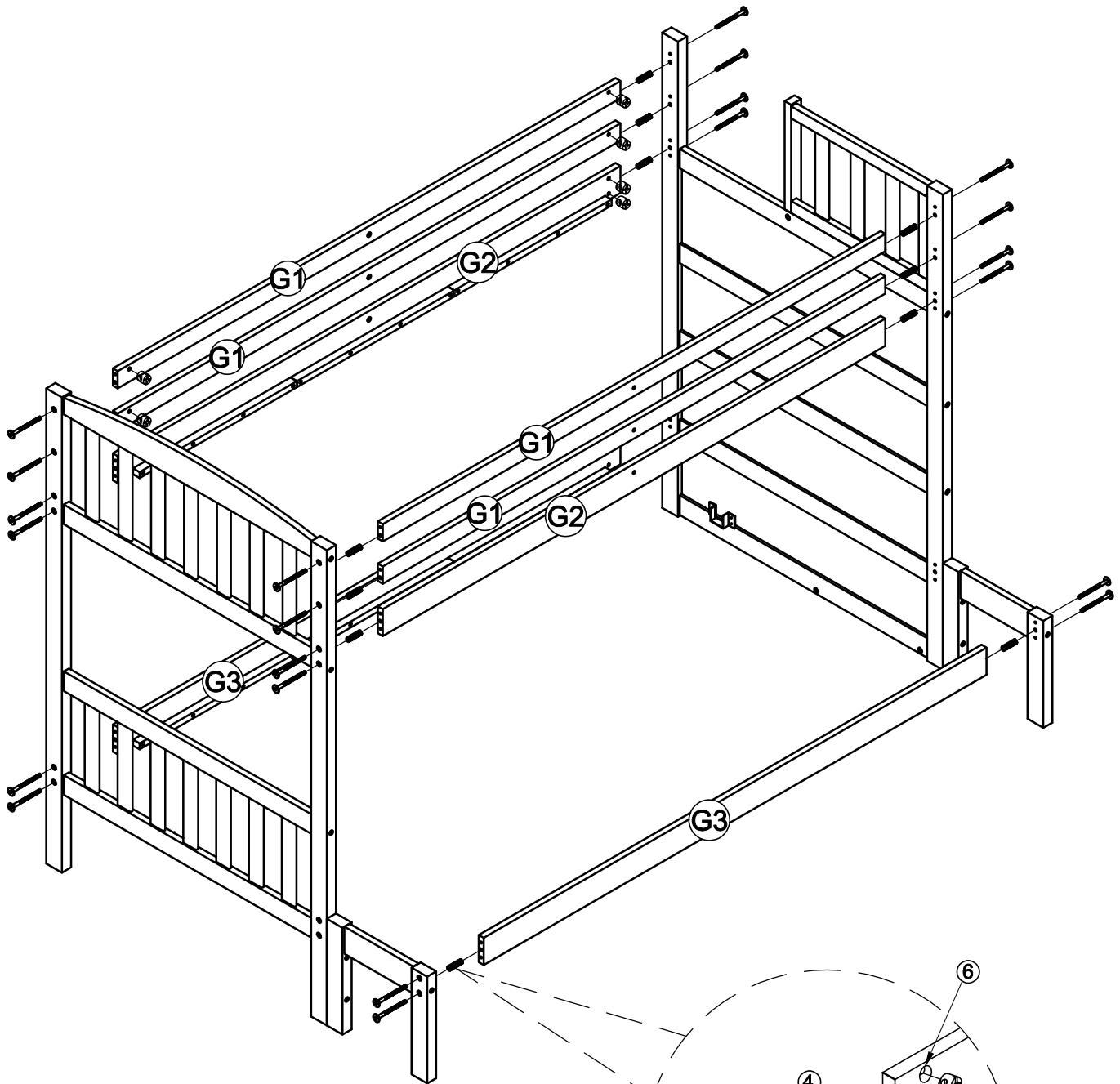

16(pcs)



Inside siderail

STEP 7: Following below illustration Using hardware #2,#3 connect Frame(completed on Step 6) with Rail G5(2).Look at detail view for more detail

3	2
	
6(pcs)	6(pcs)

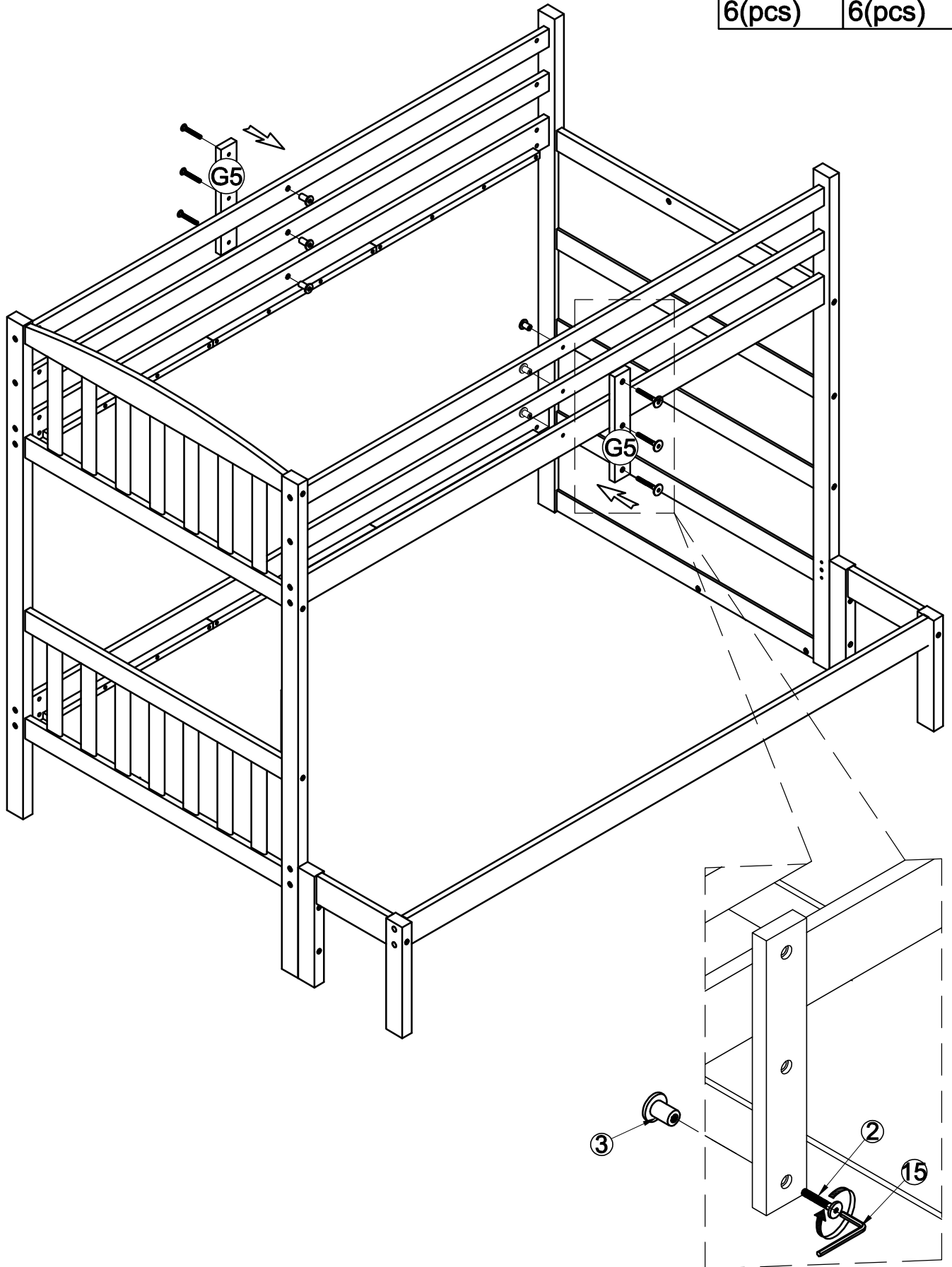

STEP 8: Assembly Middle Support Slats

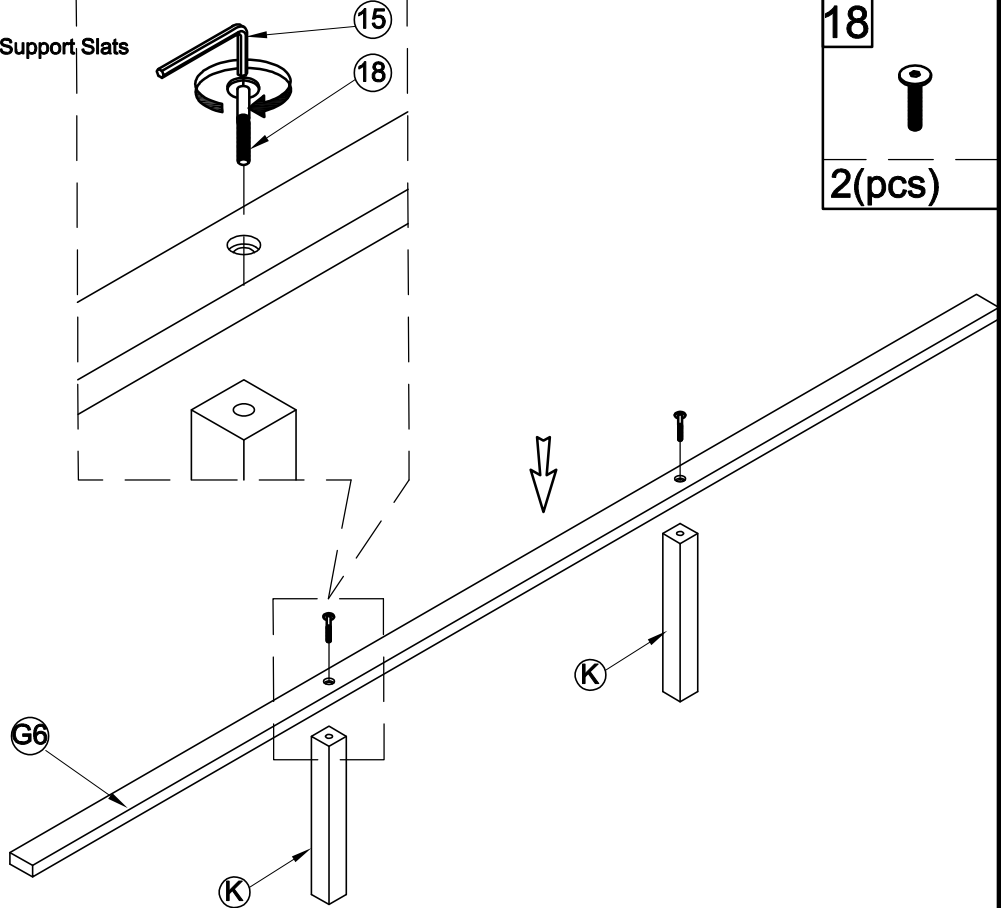

STEP 9: Assembly Steel Bracket

for hold middle support slats

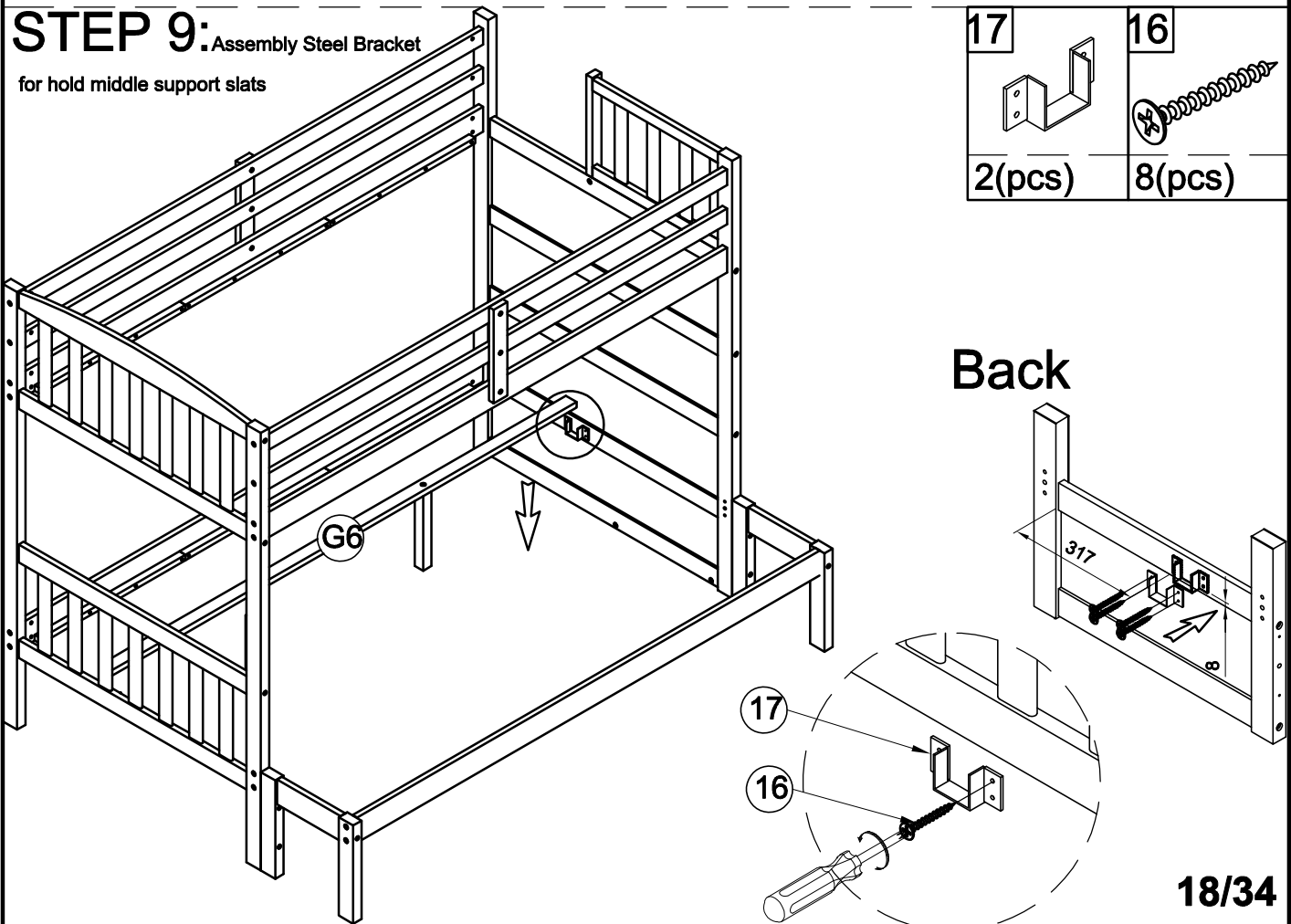

STEP 10:

Following below illustration:

-Assembly 14 short slats G7 and 28 Twin Slats G4 by using hardware #7.

-Using hardware #7 to screw wood block #8 underneath of front siderail

Look at detail view

ATTENTION: REMEMBER TO COMPLETE SCREW ALL SLATS WITH SIDERAIL BEFORE USING.

7





88(pcs)

8

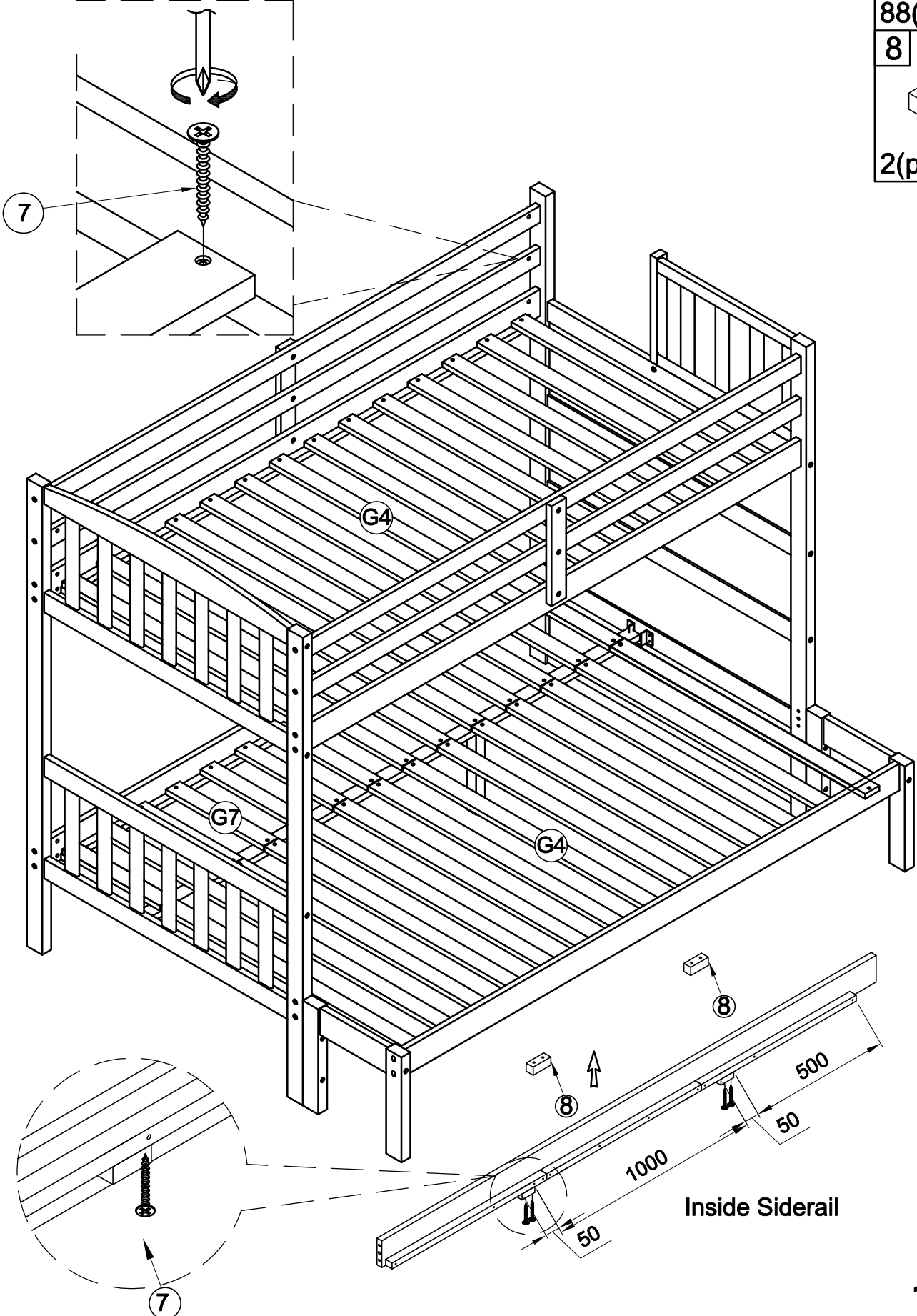

2(pcs)

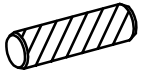

10 	9 
2(pcs)	4(pcs)

STEP 11: Following below illustration. Use hardware #9 and dowel #10 to connect D6&D5 Panel With D2 Frame. Look at detail view for more detail

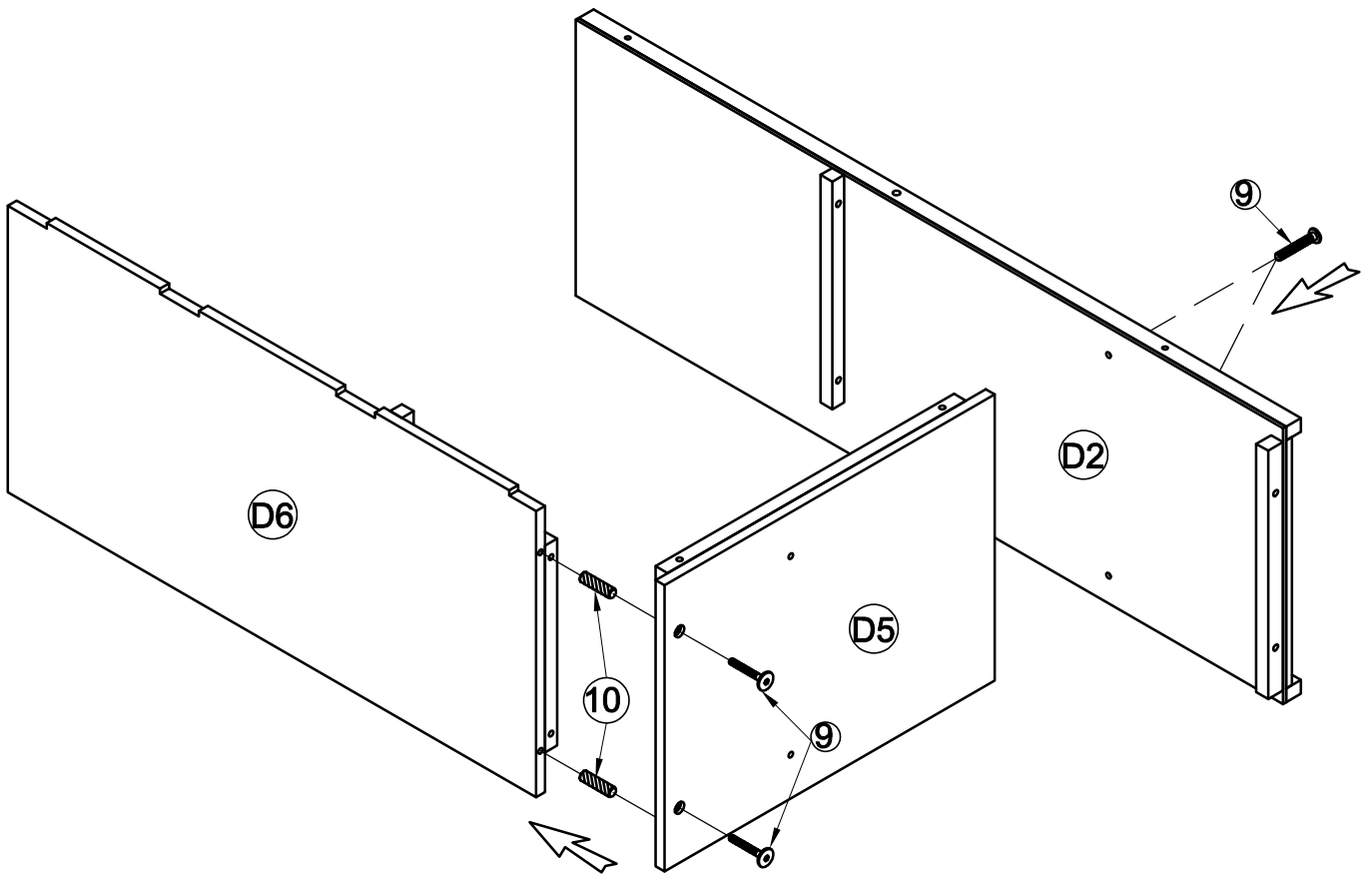

STEP 12: Following below illustration. Use hardware #9 to connect Twin -Full Bed (completed on Step 10) with Frame (completed on Step 11) and D11(2) Wood Bar. Look at detail view for more detail

9



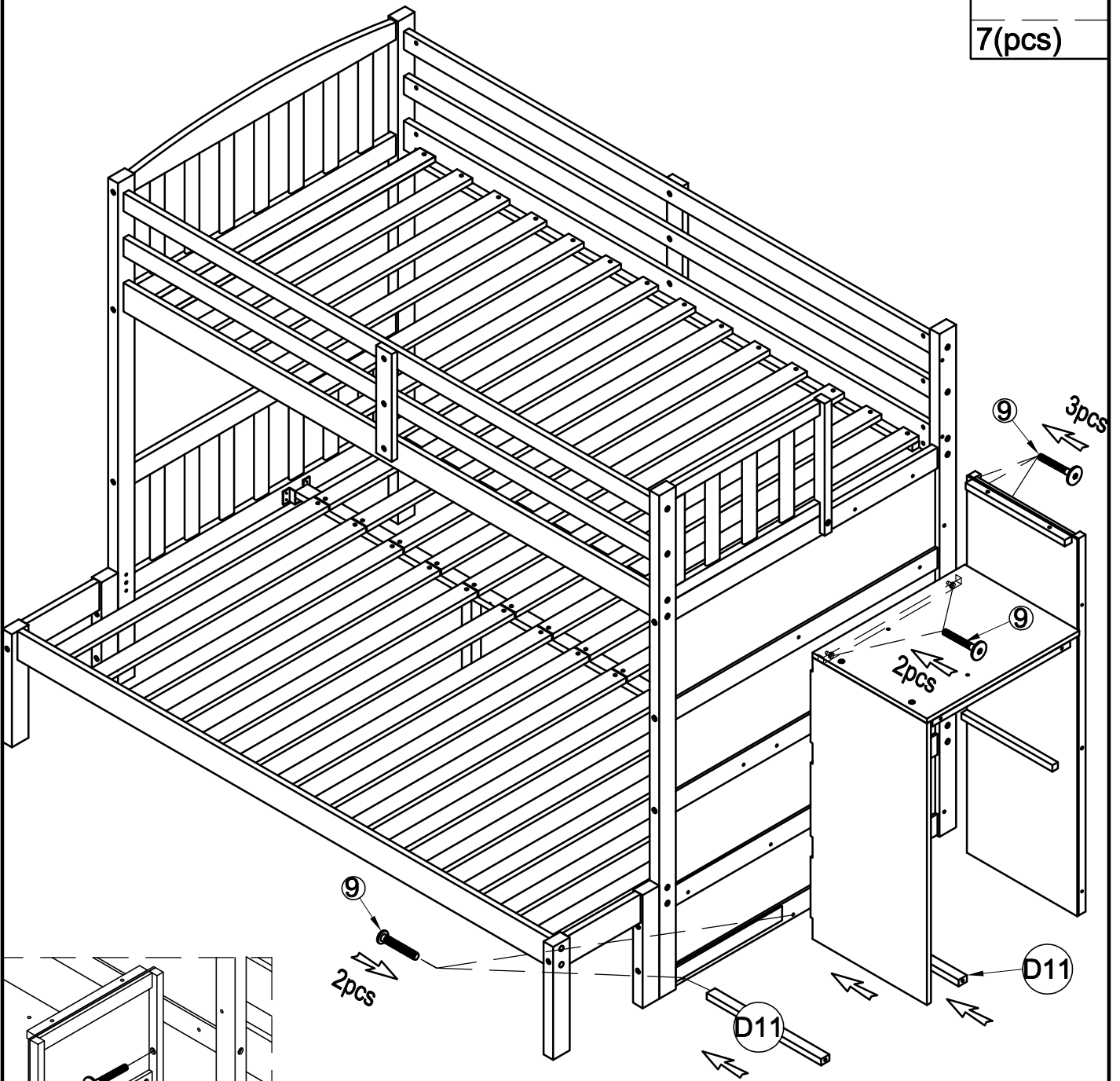

7(pcs)

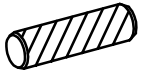

BACK VIEW

STEP 13: Following below illustration. Use hardware #9 and dowel #10 to connect D3&D4 Panel With Frame (completed on Step 12). Look at detail view for more detail

10	9
	
4(pcs)	4(pcs)

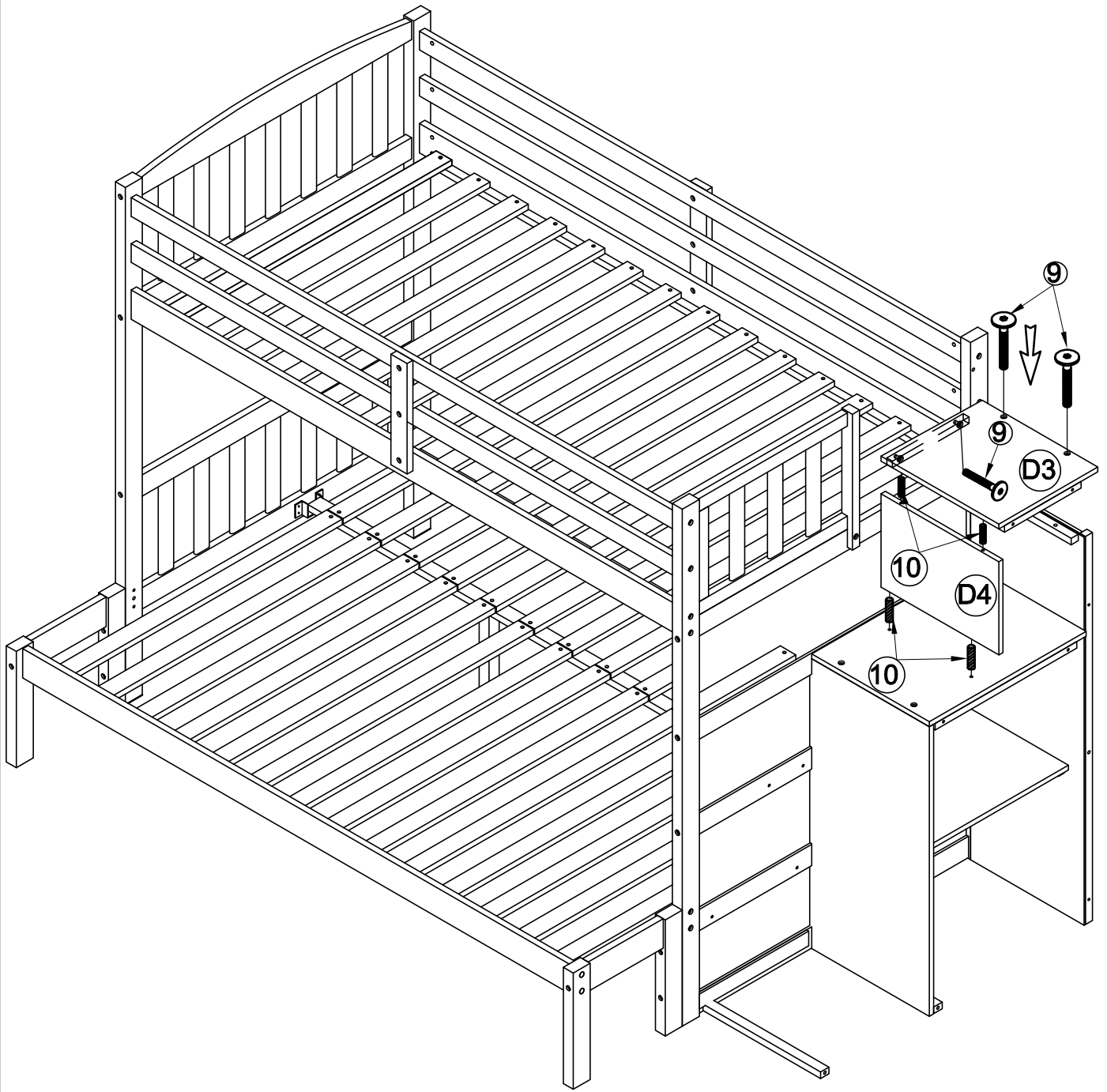

STEP 14:

Following below illustration. Use hardware #9 to connect Frame(completed on Step 13)

With Frame (completed on Step 3).Look at detail view for more detail

9



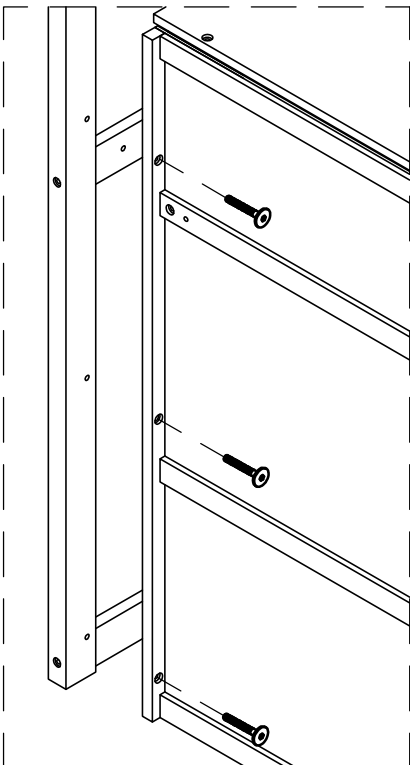
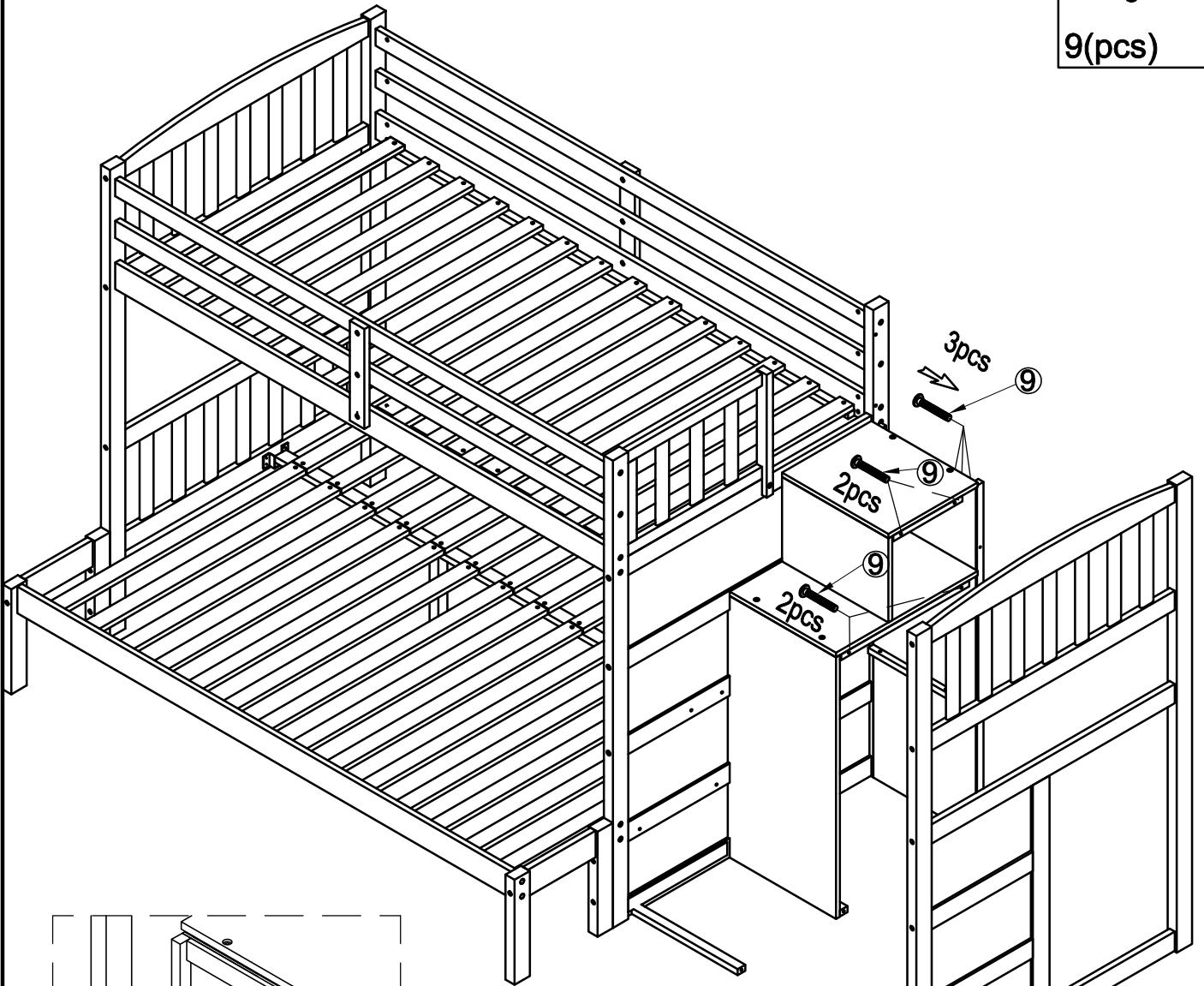

9(pcs)

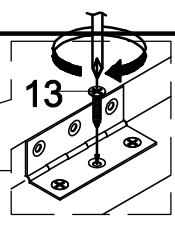
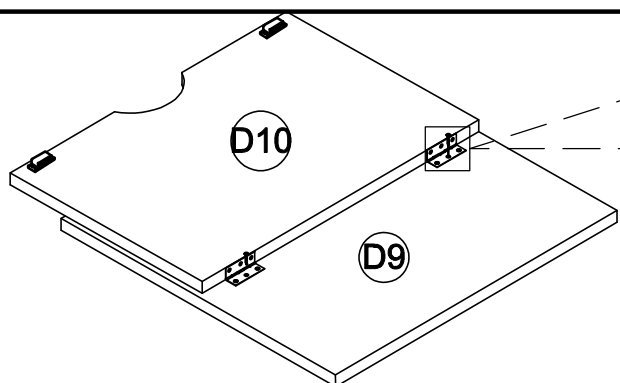

BACK VIEW

STEP 15



13

6(pcs)

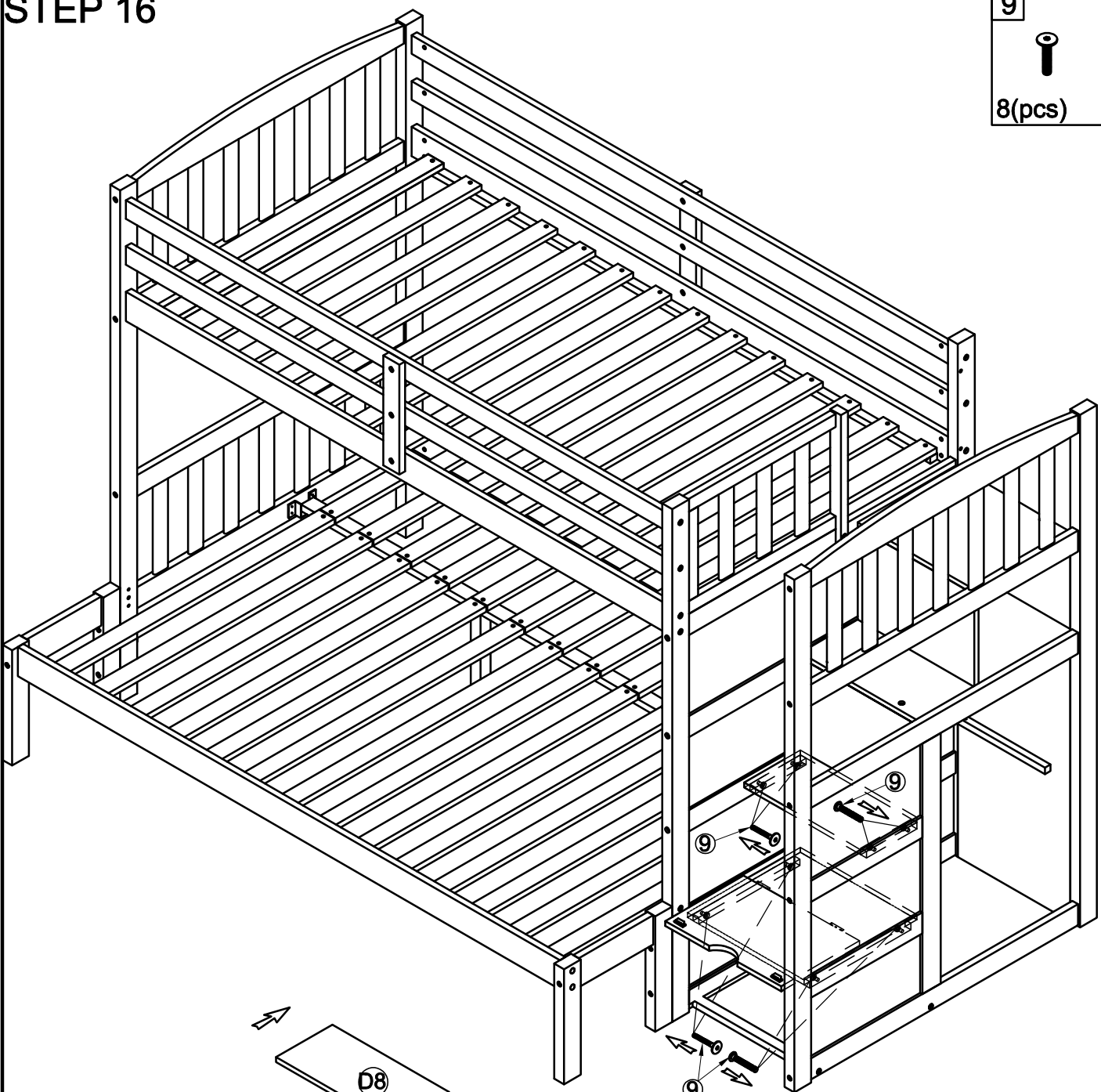
STEP 16

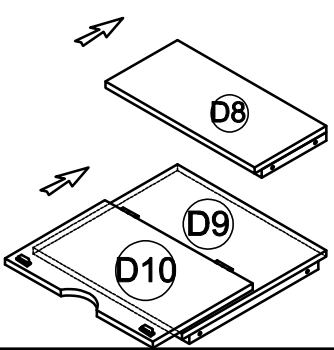

9

8(pcs)

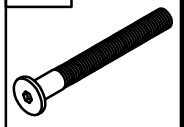

STEP 17

2.1



4(pcs)

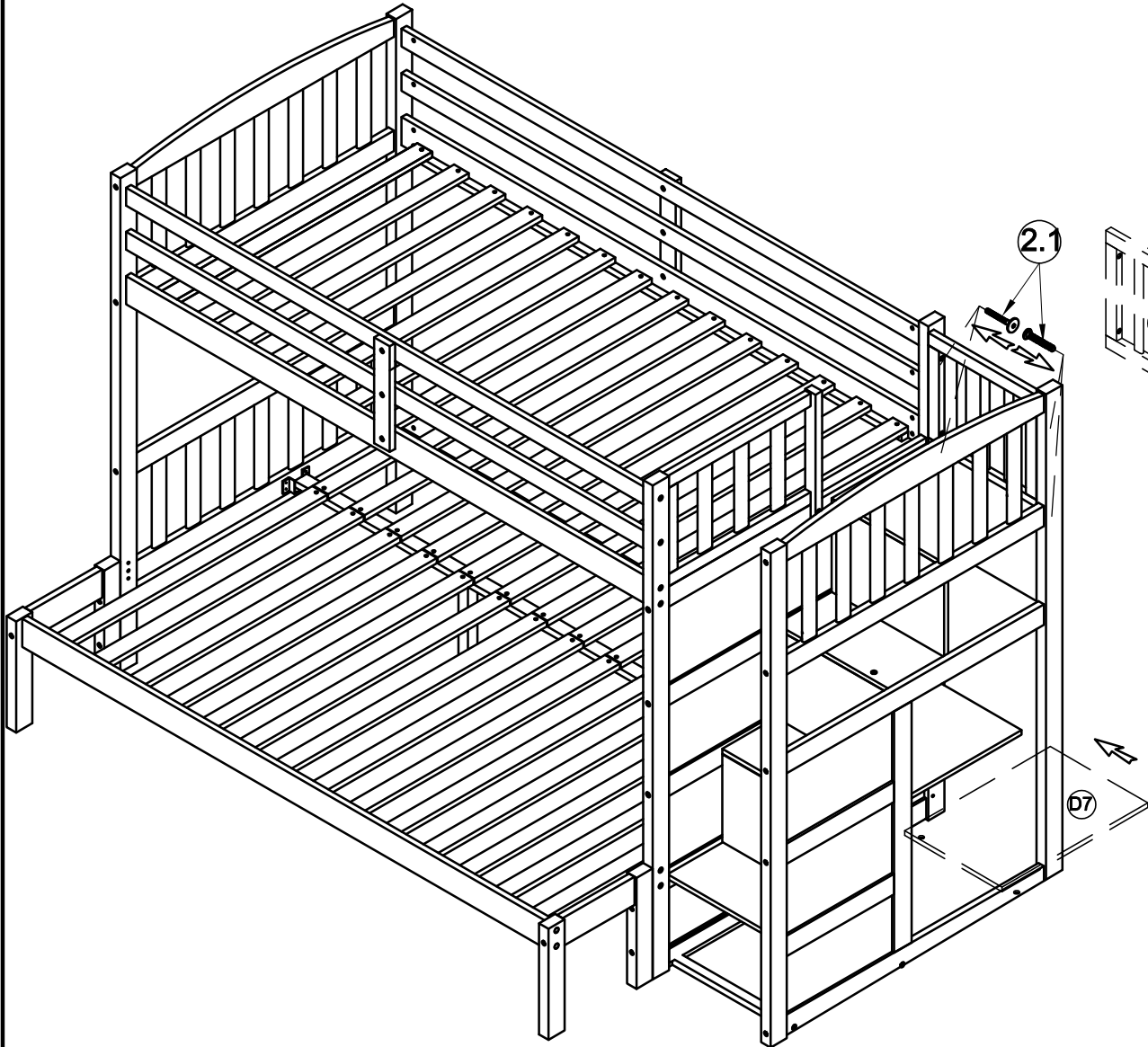

STEP 18

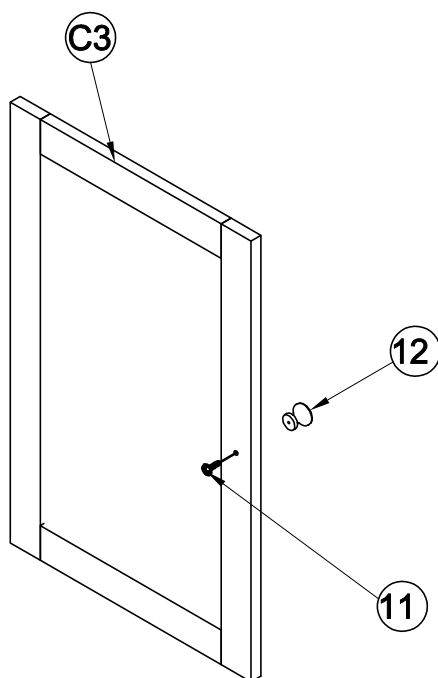

12



1 (pcs)

11



1 (pcs)

STEP 19

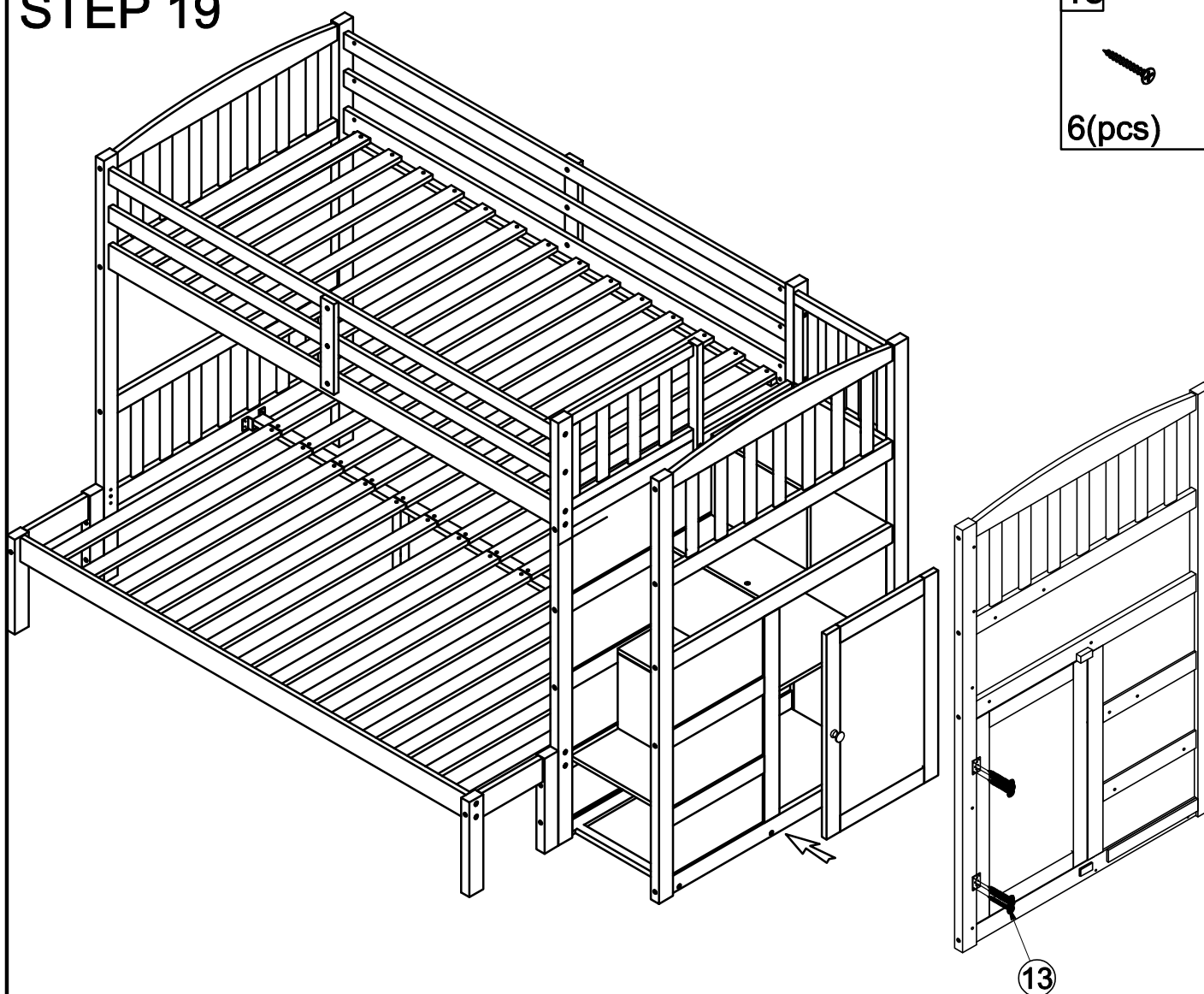

13



6 (pcs)

STEP 20-1:

ASSEMBLY UNDERBED
DRAWER

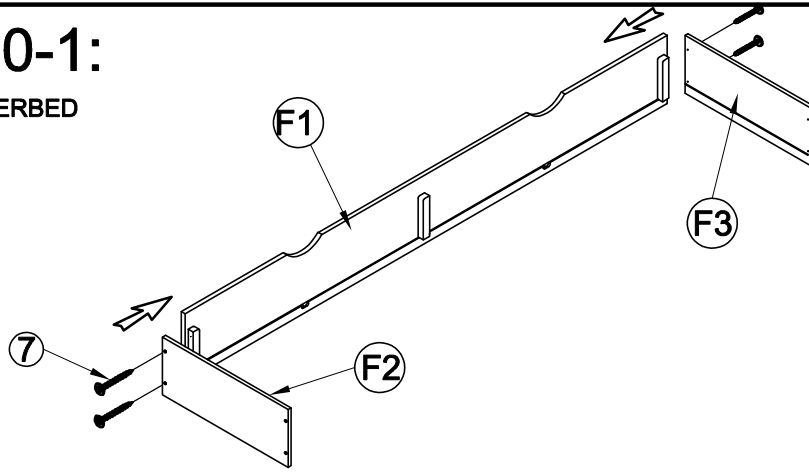

7



4(pcs)

STEP 20-2:

ASSEMBLY UNDERBED
DRAWER

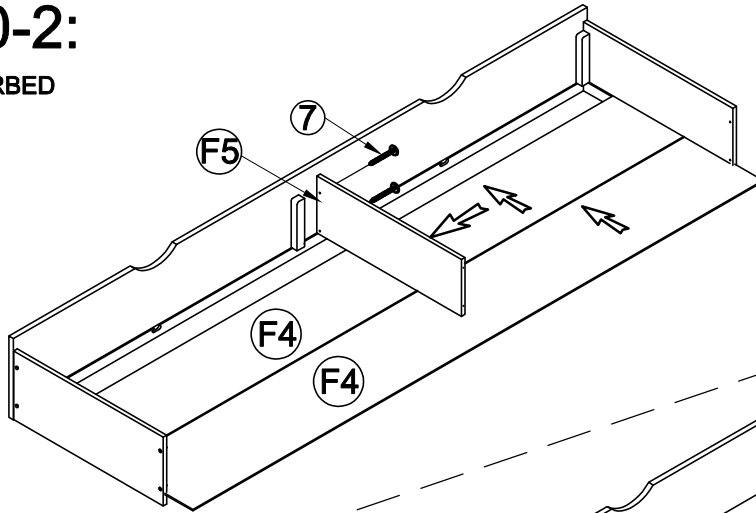

7



2(pcs)

STEP 20-3

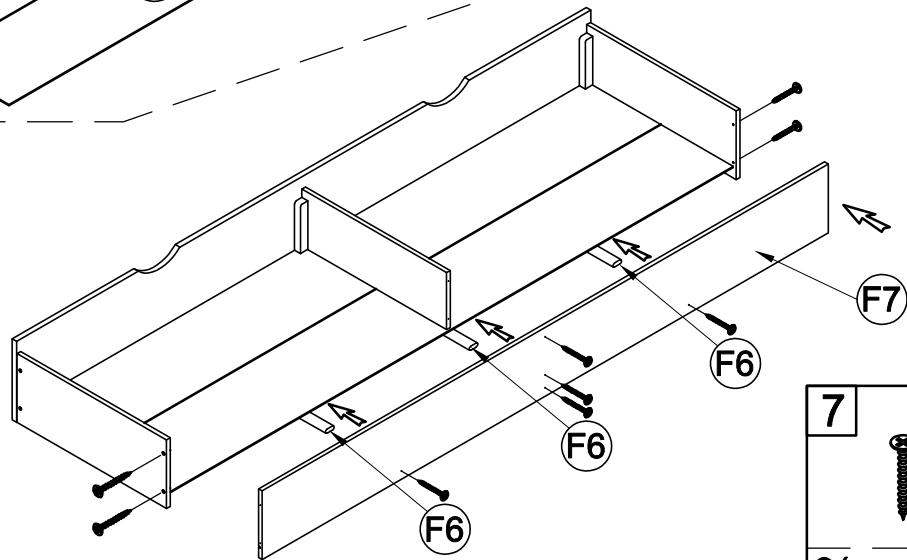

7



9(pcs)

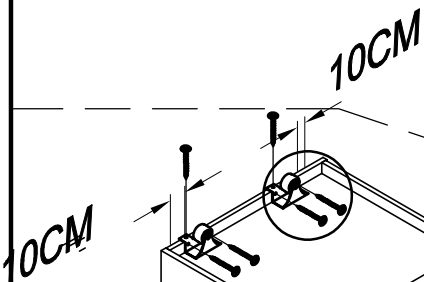

STEP 20-4

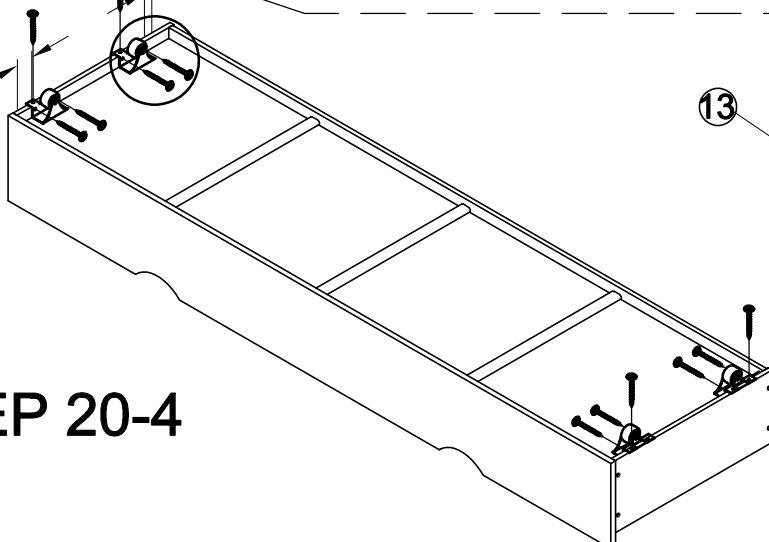

14



4(pcs)

13



12(pcs)

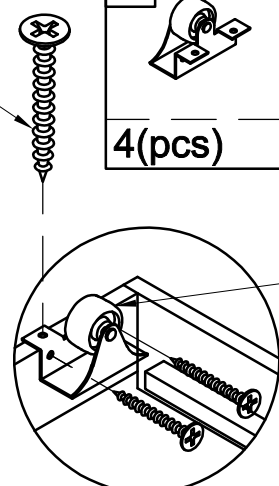

14

27/34

STEP 21-1:

Assembly Under Staircase
Drawer

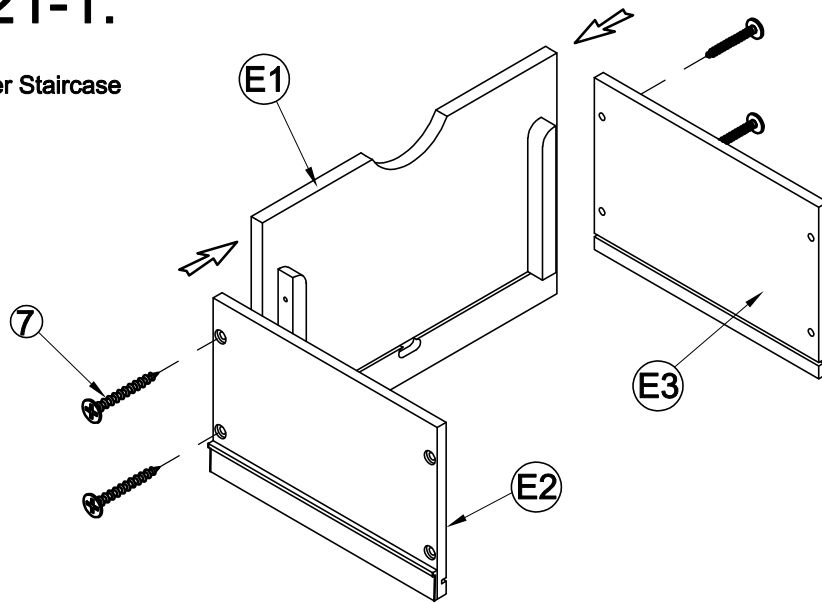

7



4(pcs)

STEP 21-2

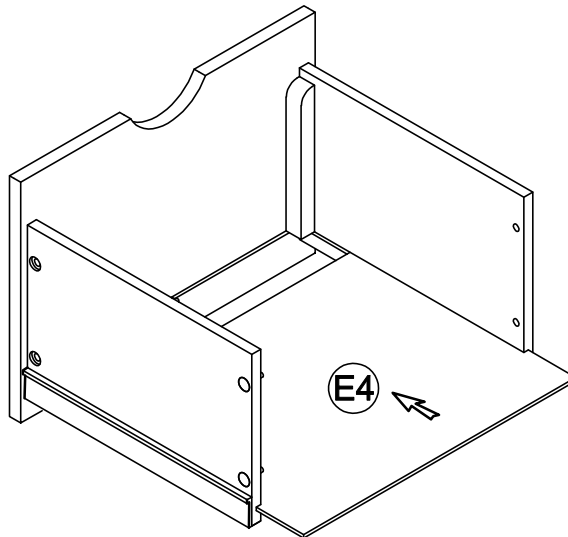

STEP 21-3

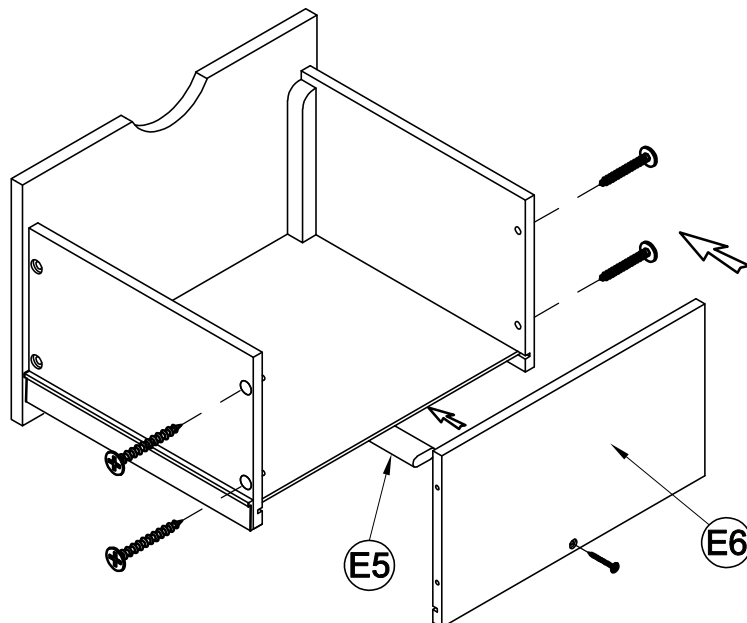

7



5(pcs)

STEP 22: Push 2 Drawers in to
under Bed and under Staircase as follow
picture.

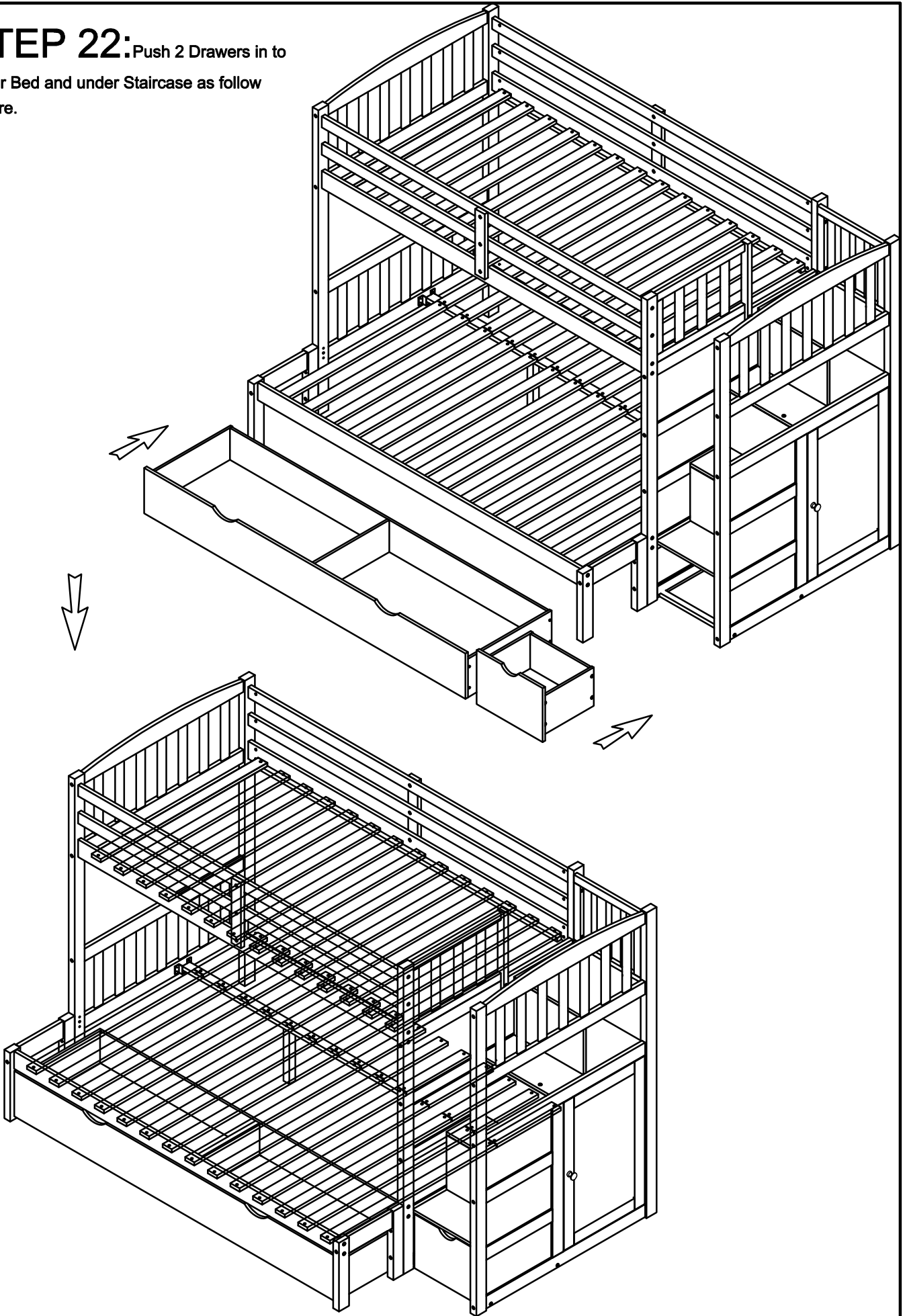

STEP 23: Remove the Under Bed

drawer when you change your mind from using
Twin-Full bed to Twin-Twin Bed

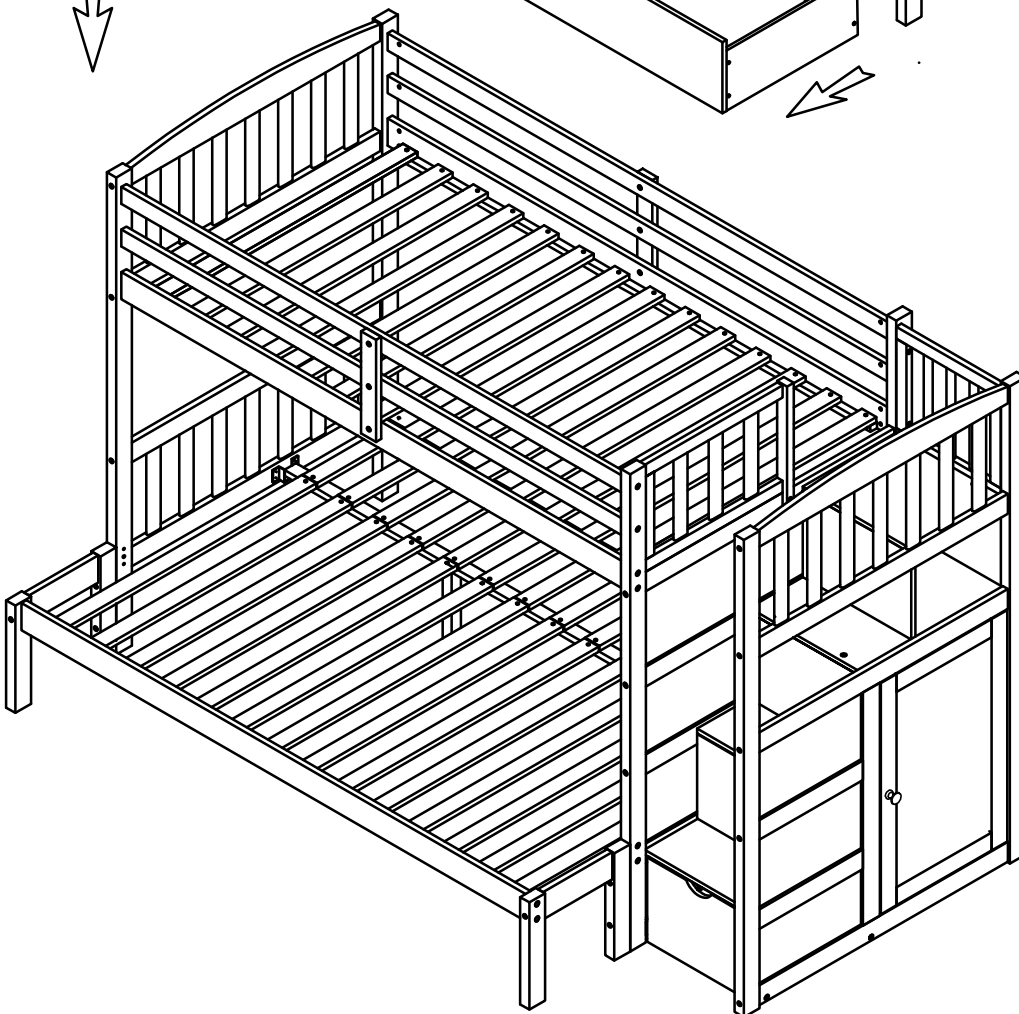
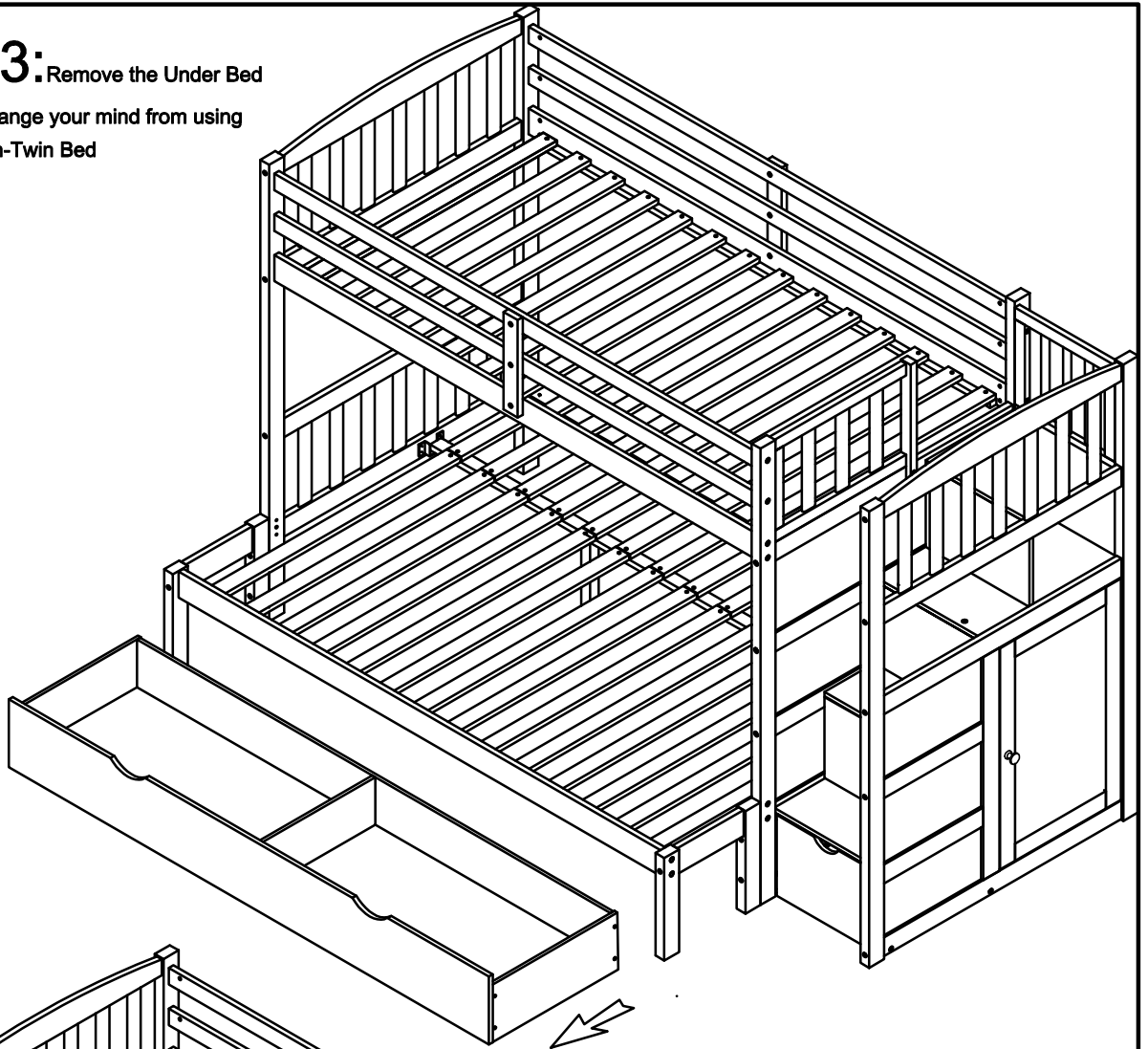

STEP 24: Disassembly Bottom Bed Slats

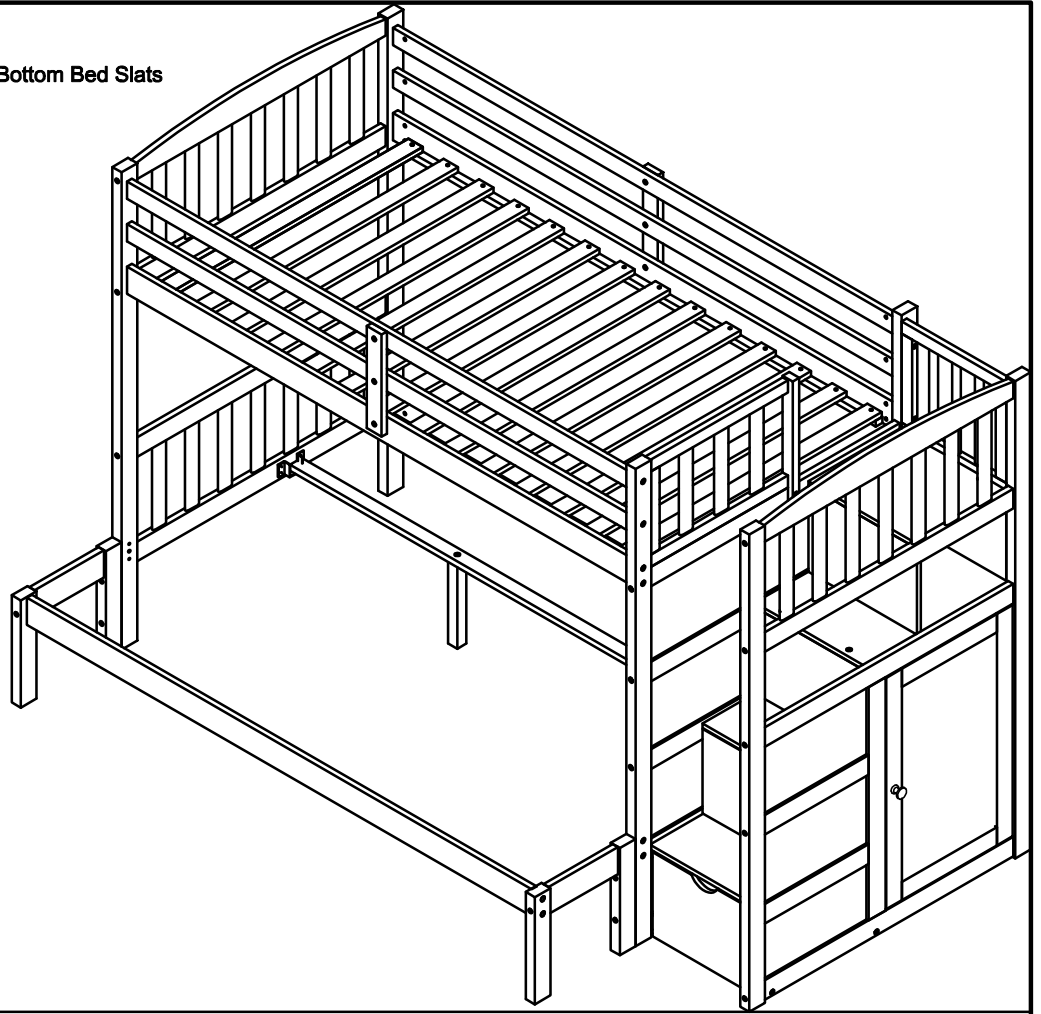

STEP 25: Disassembly extension kit

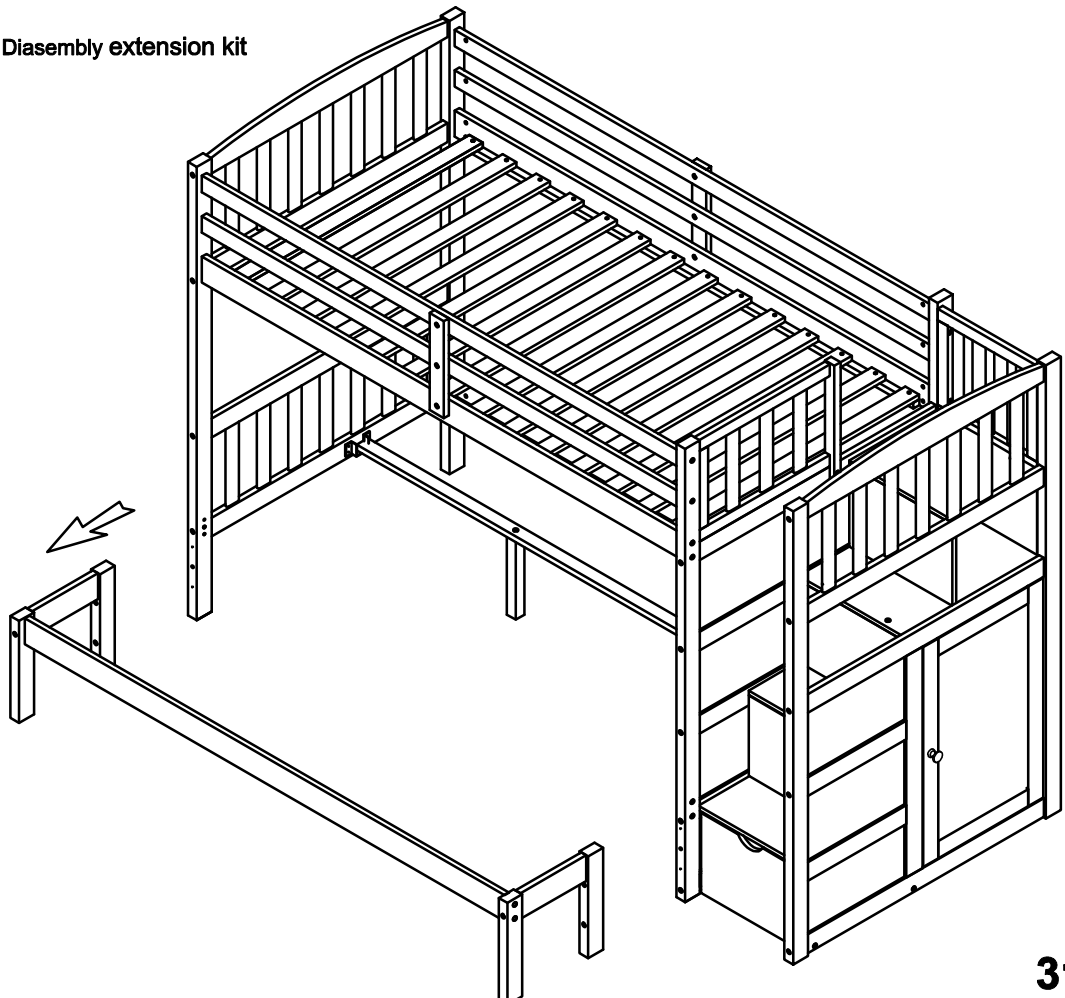

STEP 26: Disassembly Side Rail(front)

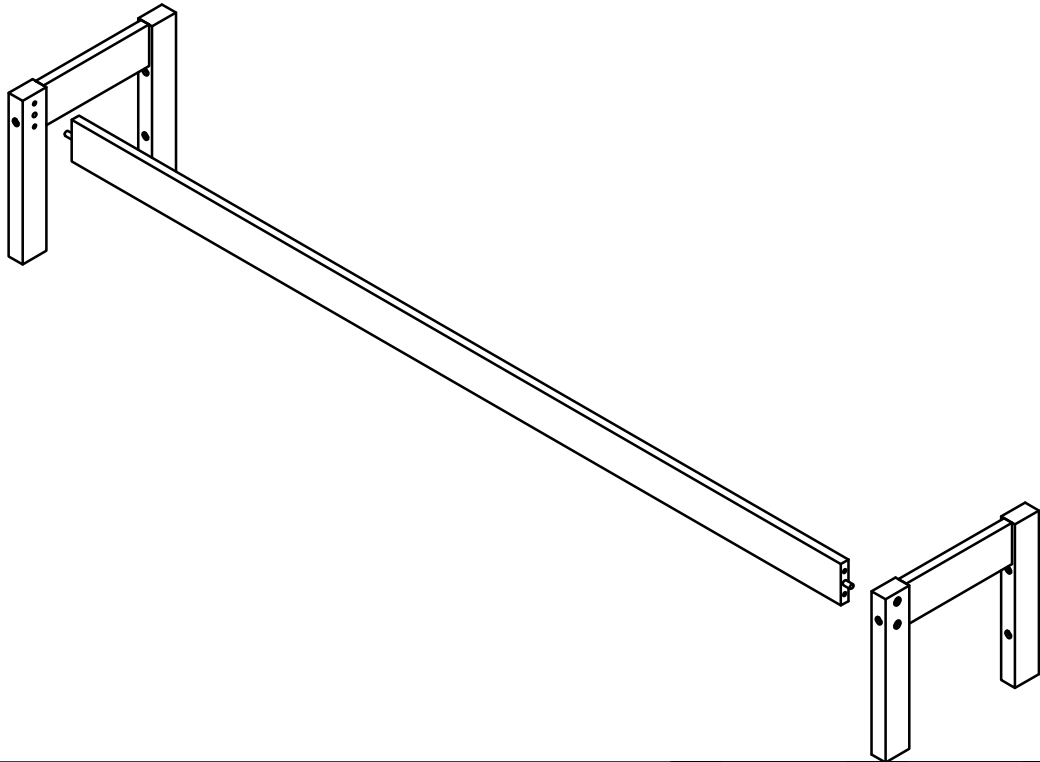

STEP 27: Following the illustration. Use the Siderail G which was disassembled from Step 26 to assembly with Legs

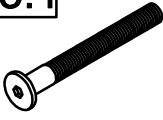
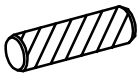
6	5.1	4
		
4(pcs)	4(pcs)	2(pcs)

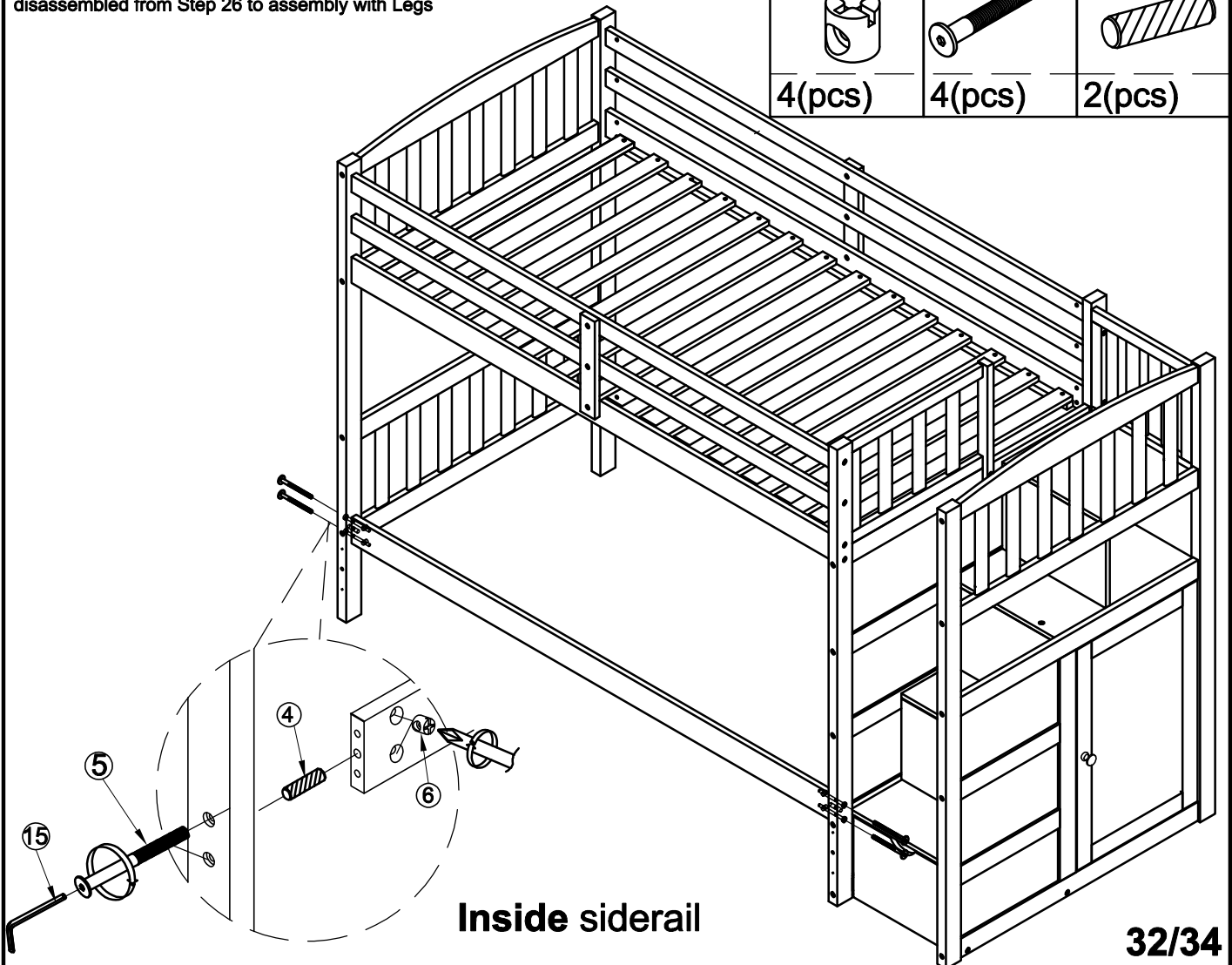

STEP 28:

Follow the illustration . Assembly 14 Twin Slats G4 on bottom

Bed siderail

7



28(pcs)

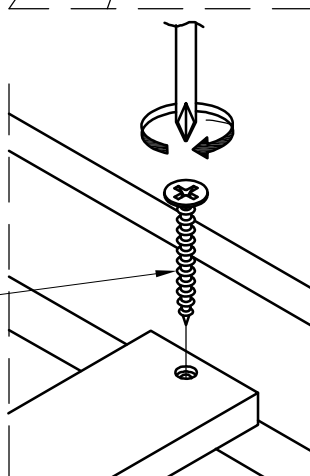
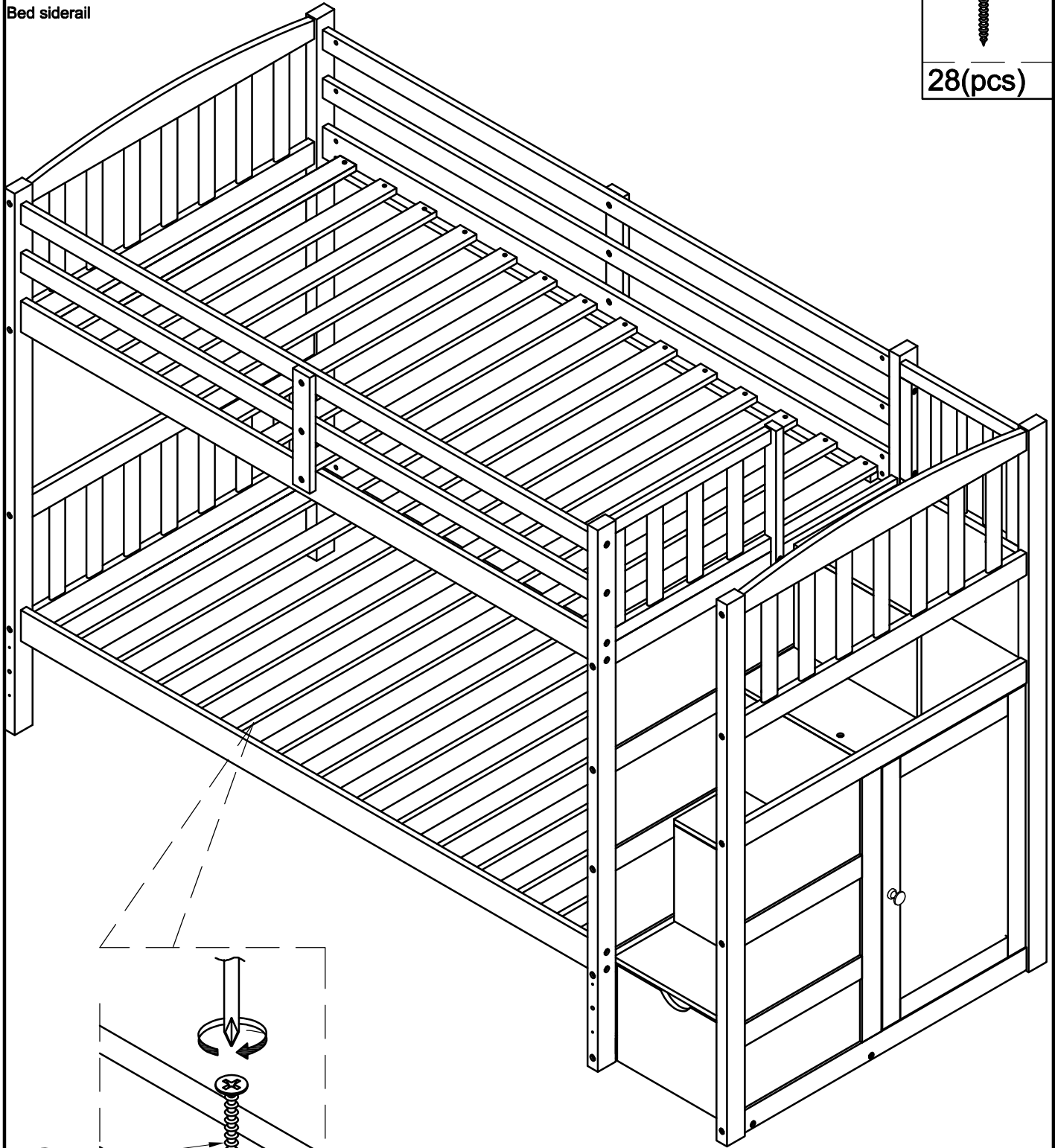

ATTENTION: REMEMBER TO COMPLETE SCREW ALL SLATS WITH SIDERAIL BEFORE USING.

STEP 29: CONGRARULATION. YOU HAVE COMPLETED THE BED.

Just one more step to push the Under Bed Drawer into it position

