

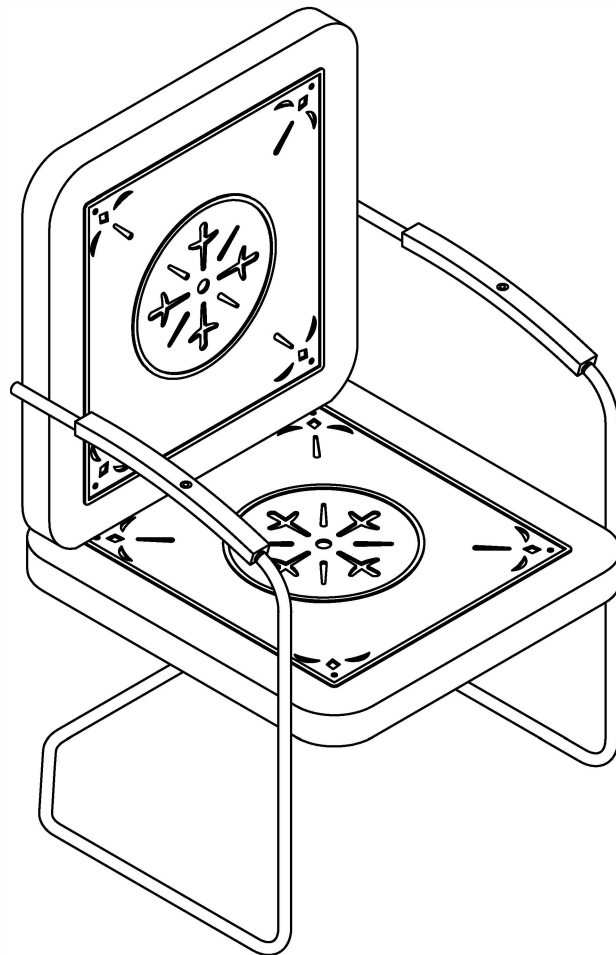

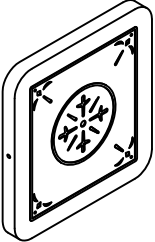

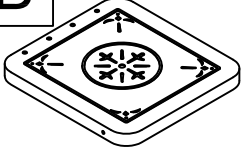

Metal Chair

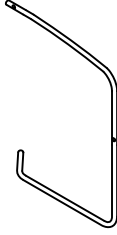
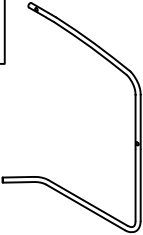
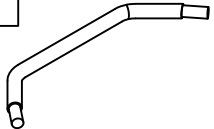
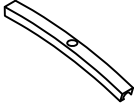

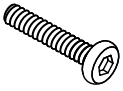
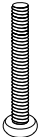

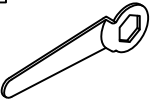

PART LIST

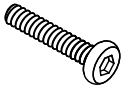
A 	B 	C 	D 	E 
Chair Back 1 PC	Chair Seat 1 PC	Left Support Leg 1 PC	Right Support Leg 1 PC	Leg Connector 1 PC
F 				
Arm Pad 2 PCS				

HARDWARE LIST

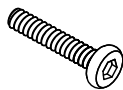
#1  M6X13mm	#2  M6X42mm	#3 	#4 	#5 
Bolt 4 PCS	Long Bolt 4 PCS	Hex Nut 8 PCS	Flat Washer 12 PCS	Plastic Washer 4 PCS
#6 	#7 	#8 	#9  M6X25mm	
Wrench 1 PC	Allen Wrench 1 PC	Round Plastic Washer 4 PCS	Medium Bolt 2 PCS	

EXTRA HARDWARE LIST

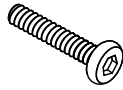
#1  M6X13mm	#2  M6X42mm	#3 	#4 	#8  M6X25mm
Bolt 1 PC	Long Bolt 1 PC	Hex Nut 2 PCS	Flat Washer 4 PCS	Medium Bolt 1 PC

IMPORTANT NOTE: WE RECOMMEND TWO PEOPLE WORK TOGETHER TO ASSEMBLE THE CHAIR

Step 1. Lay chair back (part A) down on a soft flat surface, such as carpet, as shown below. Attach chair seat (part B) to chair back (part A) using bolts (part #1), flat washers (part #4), hex nuts (part #3), wrench (part #6) and allen wrench (part #7).

NOTE: Please do not fully tighten bolts until unit is fully assembled.

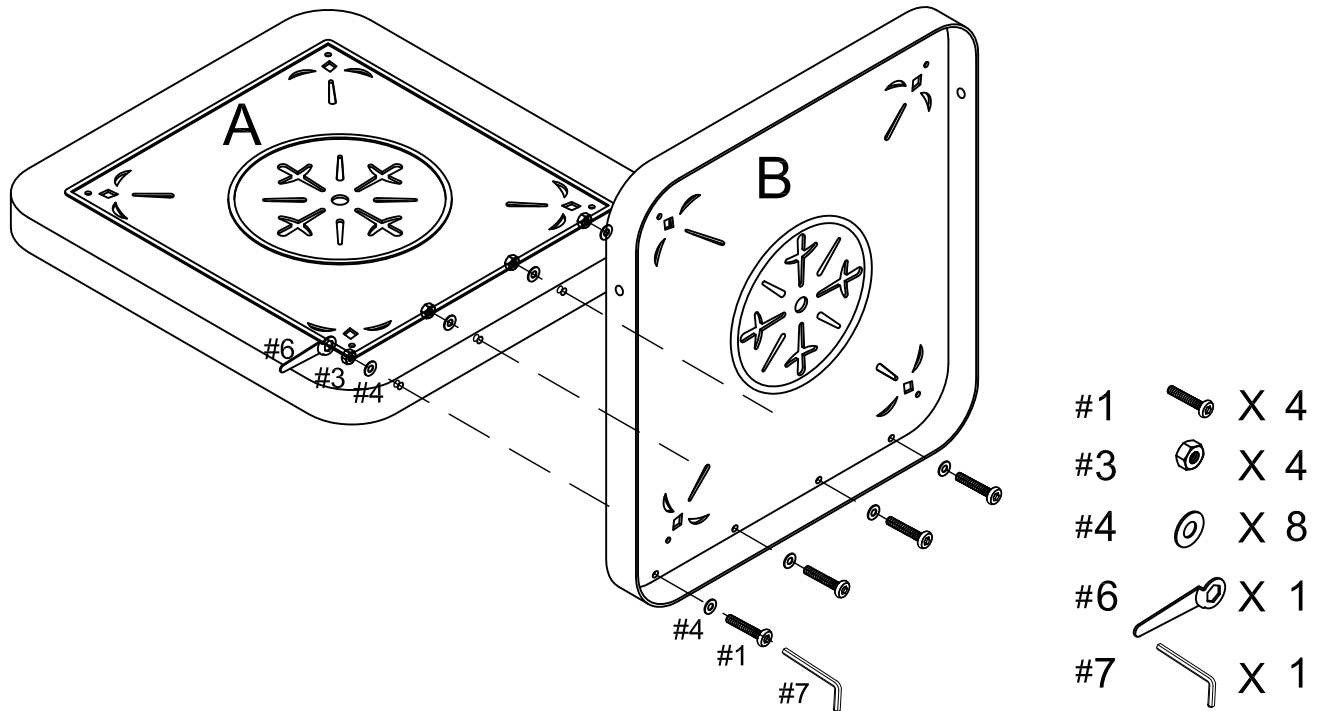

Step 2. Attach left support leg (part C), leg connector (part E) and right support leg (part D). Attach arm pads (part F) to left support leg (part C) and right support leg (part D) using medium bolts (part #9) and allen wrench (part #7).

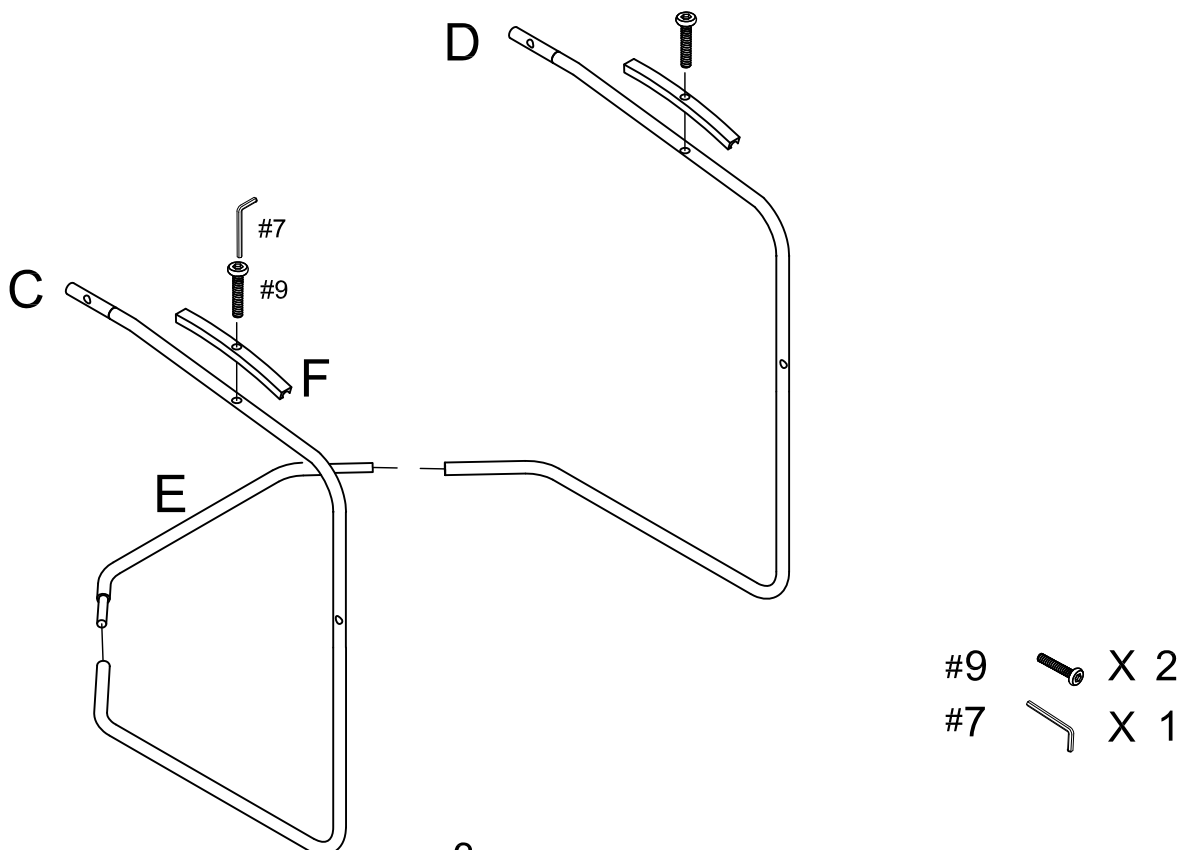

Step 3. Attach support legs (parts C & D) to chair back (part A) and chair seat (part B) using long bolts (part #2), Round Plastic Washer (part #8) and flat washers (part #4), plastic washers (part #5), hex nuts (part #3), wrench (part #6) and allen wrench (part #7) .

NOTE: Please fully tighten all bolts at this time.

