

TV STAND

USER MANUAL

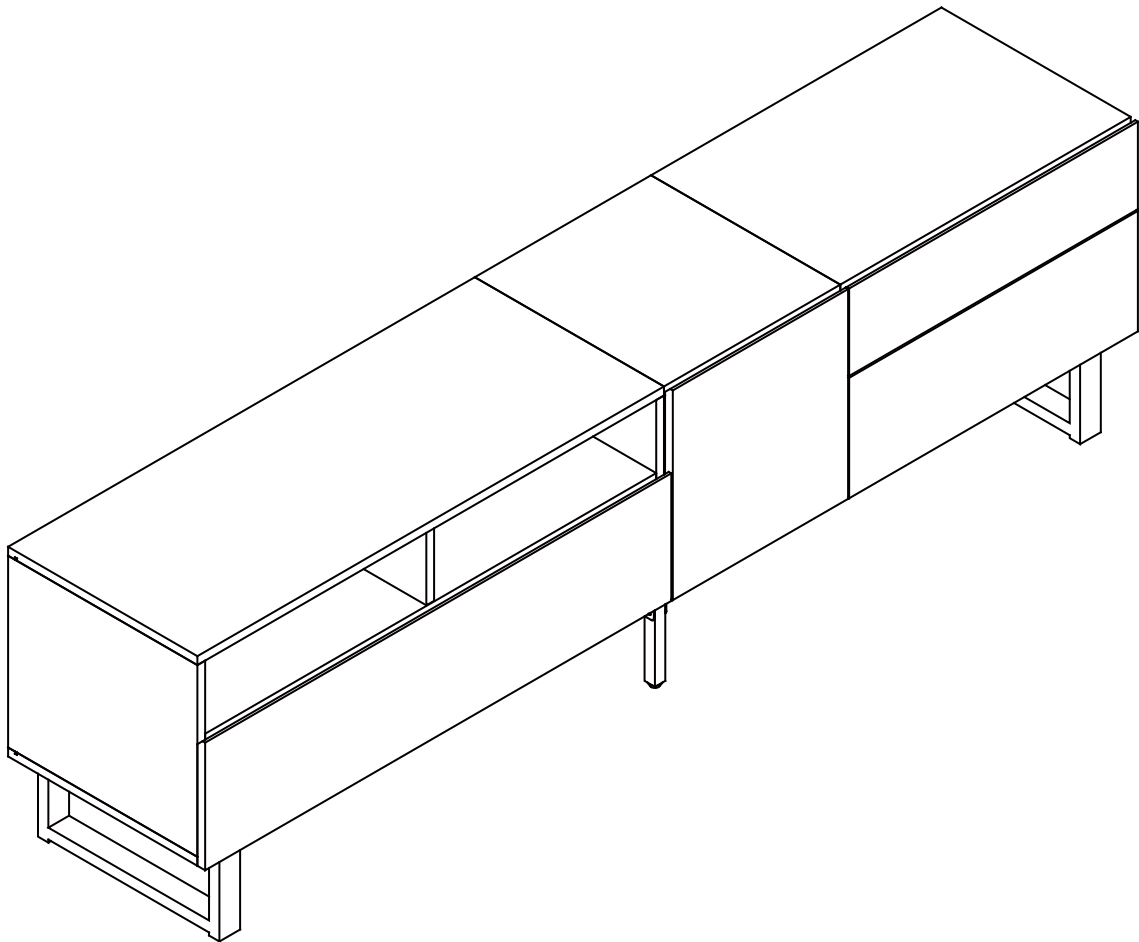

SAVE THESE INSTRUCTIONS FOR FUTURE USE

PLEASE DO NOT RETURN TO STORE



**Please do not return this product to the retailer!!
We are able to assist you in ANY way**

If you find that you have any trouble with assembly or missing or damaged parts please contact the seller.

Before Installation

Important – Please read these instructions fully before starting assembly

Thank you for purchasing this quality product. Be sure to check all packing materials carefully for small parts, which may have come loose inside the carton during shipment. Identify and count all items according to the PARTS LIST and/or HARDWARE LIST shown below. Check you have all the components and tools listed on the following pages.

- We recommend that you assemble this product with the assistance of another person; this will make the assembly easier, and will help eliminate damage to the product or injury to persons during assembly.
- Please do not over tighten screws or bolts until the assembly is completed.
- Keep children and animal away from the work area, small parts could choke if swallowed.
- Please put all parts on a non-abrasive floor before assembly, and follow the assembly steps to assemble your newly purchased product correctly and efficiently.

Cam Lock Assembly Instructions

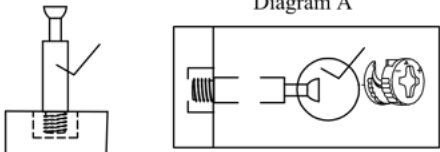
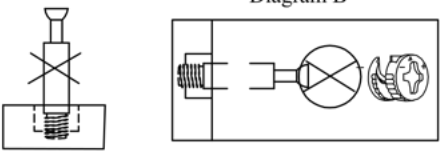
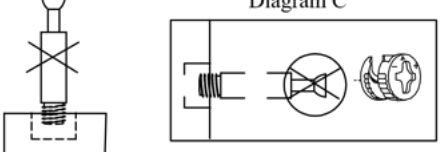
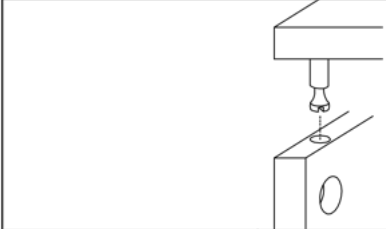
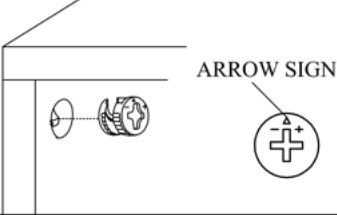
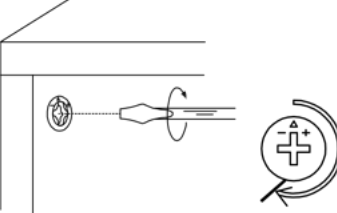
	<p>Diagram A</p> <p>Insert Cam Bolt into hole as shown in diagram A.</p>
	<p>Diagram B</p> <p>Make sure not to insert the Cam Bolt: Too deep as shown in figure B as this will cause the Cam Lock to be misaligned and unable to interlock properly.</p>
	<p>Diagram C</p> <p>Also avoid inserting the Cam Bolt too close to the surface of the hole as shown in figure C, as this will cause the Cam Lock to be too loose, and not interlock properly.</p>
	<p>Connect the panels together.</p>
	<p>ARROW SIGN</p> <p>Insert the Cam Lock so the side opening fits over the head of the Cam Bolt.</p>
	<p>To tighten the Cam Lock, turn it clockwise on half a turn with a flat screwdriver. <i>*Do not use an automatic screwdriver as it may bend or break if too much power is imposed.</i></p>

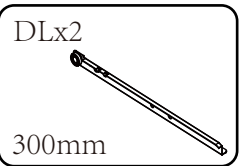
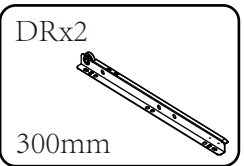
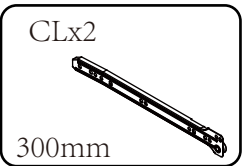
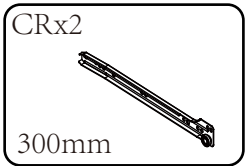
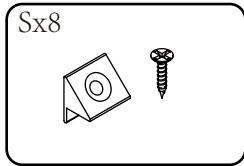
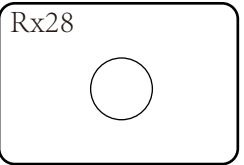
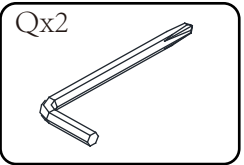
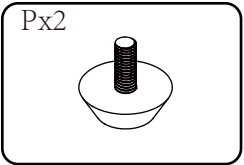
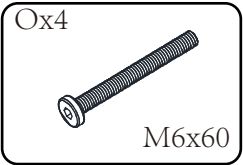
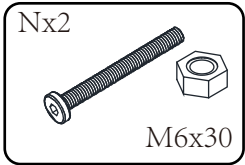
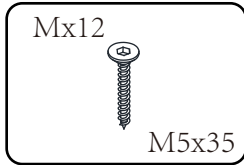
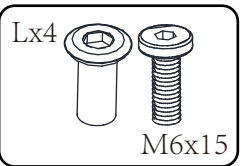
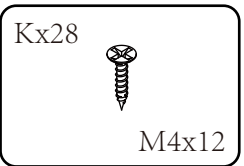
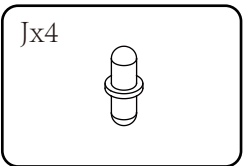
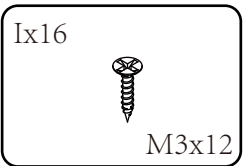
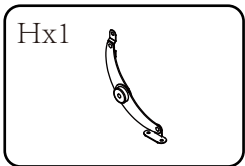
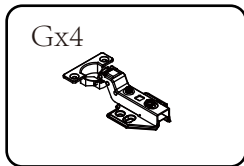
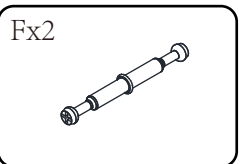
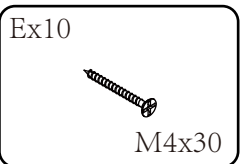
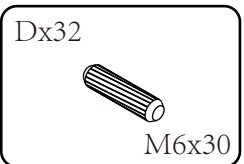
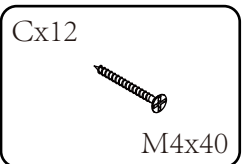
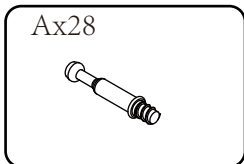
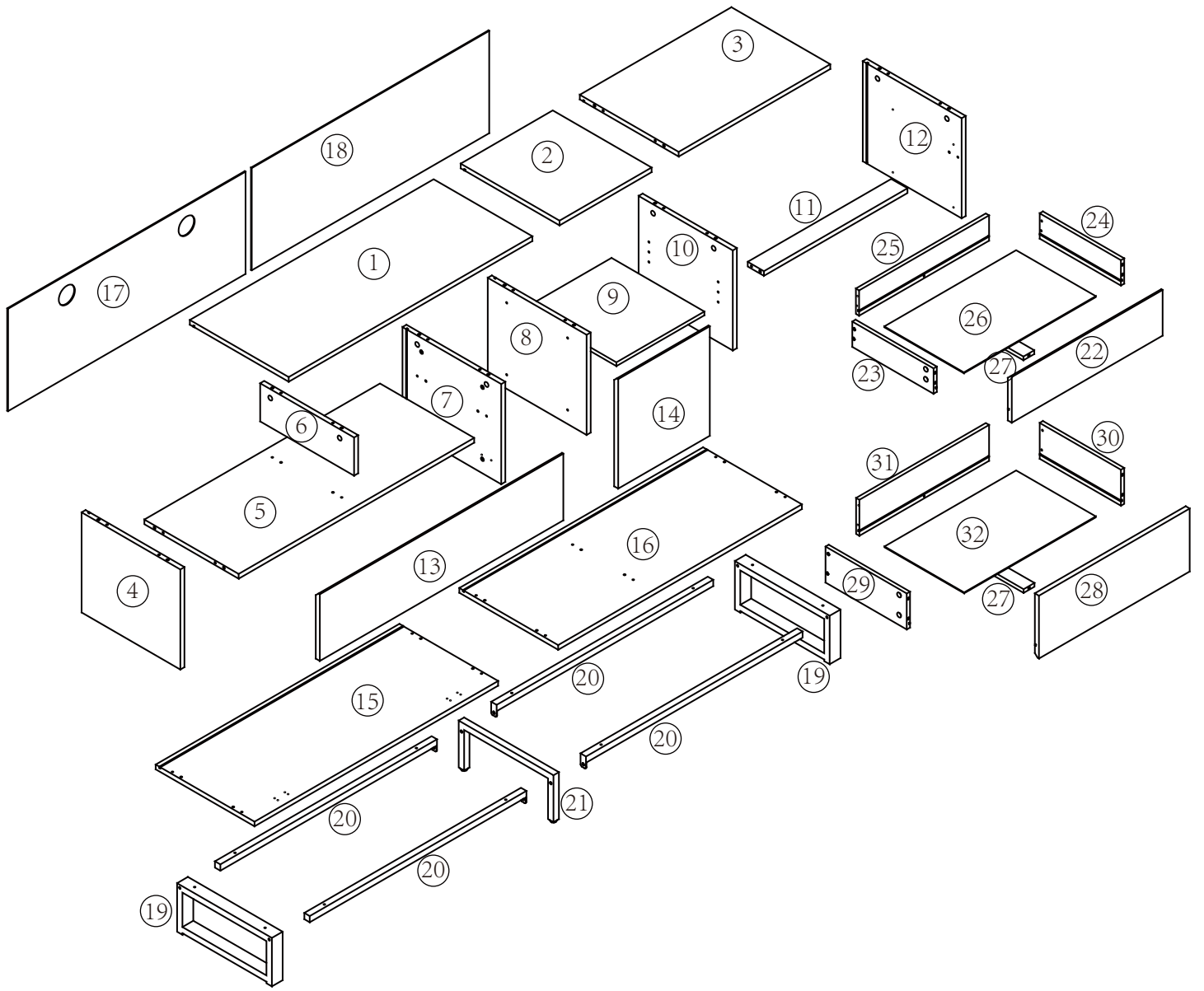

STEP 1

Ax18

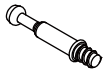

CRx2

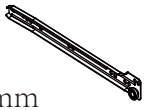

300mm

CLx2

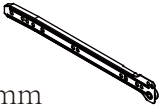

300mm

Ix8



M3x12

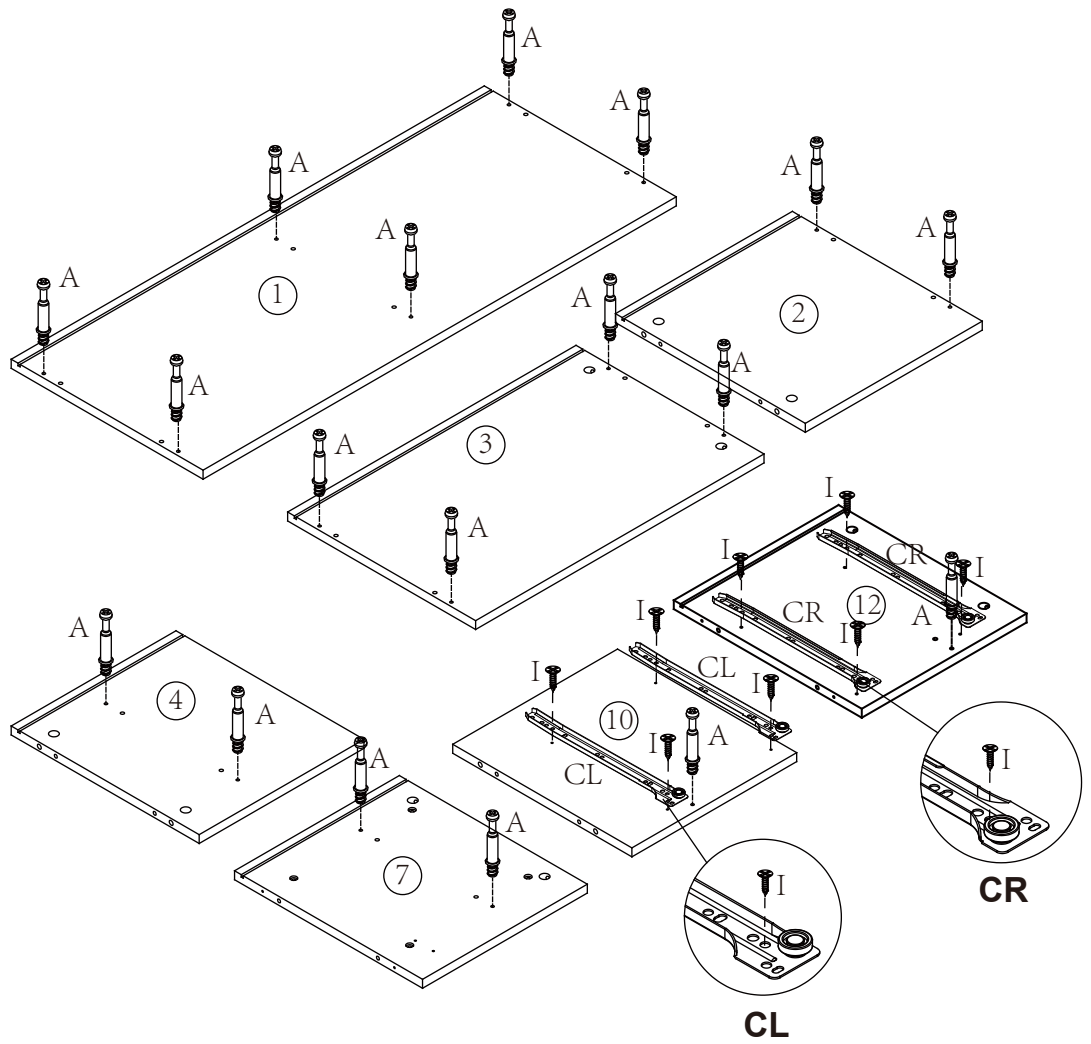

STEP 2

Fx2

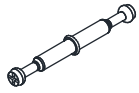

Bx4



Dx2



M6x30

Lx4

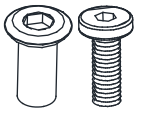

M6x15

Qx2

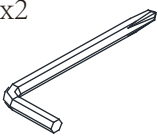

Rx8

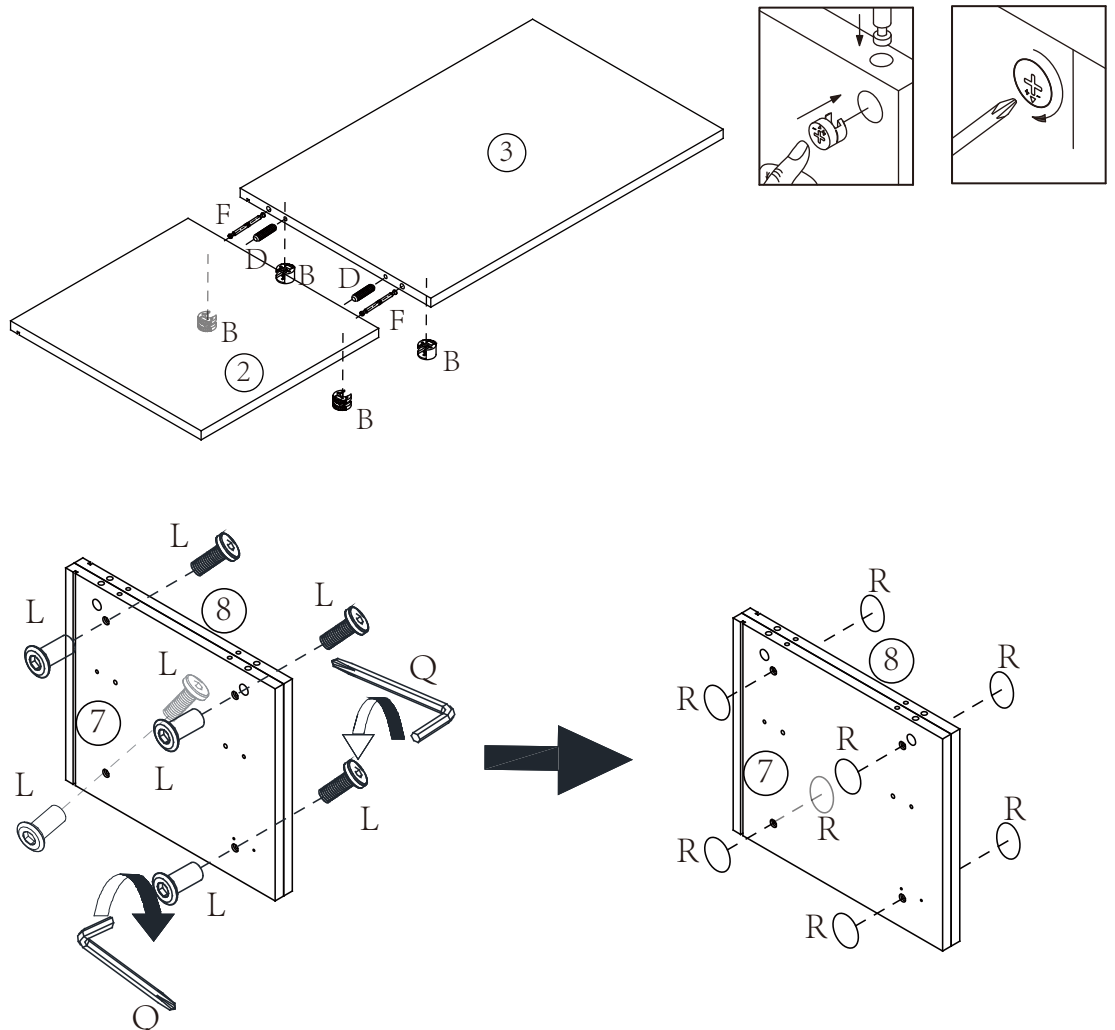

STEP 3

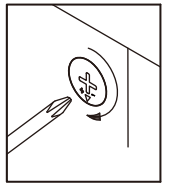
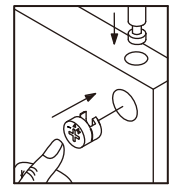
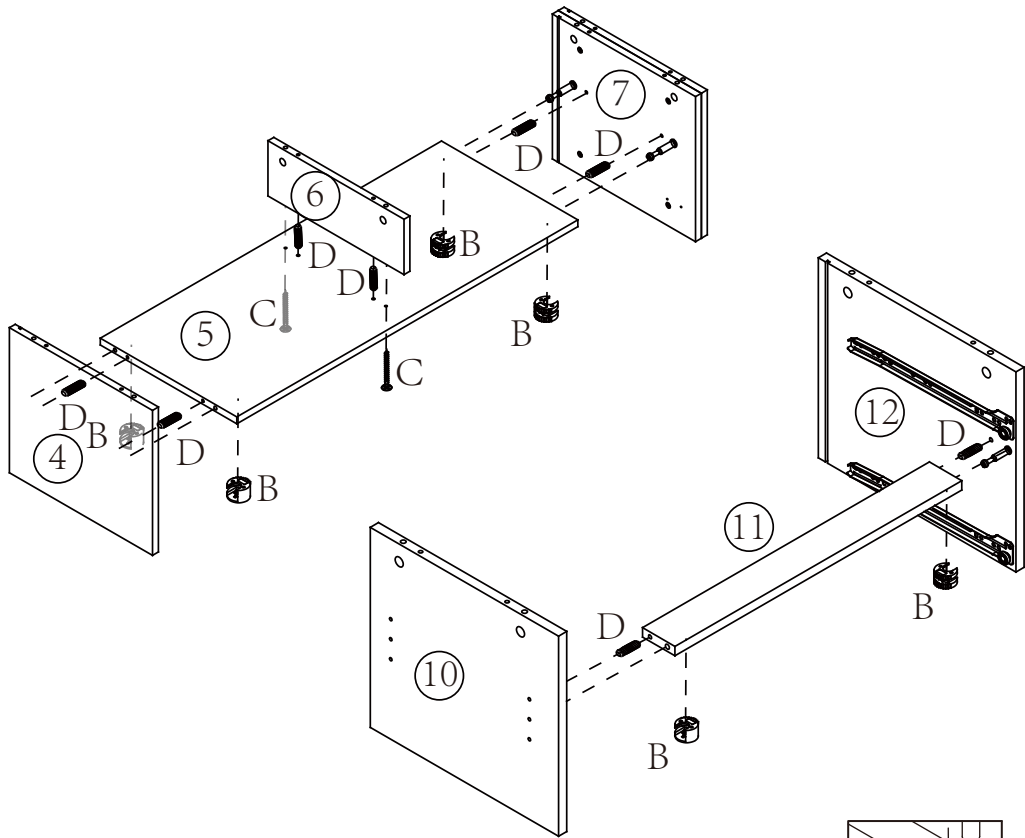
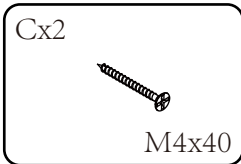
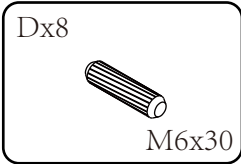

STEP 4

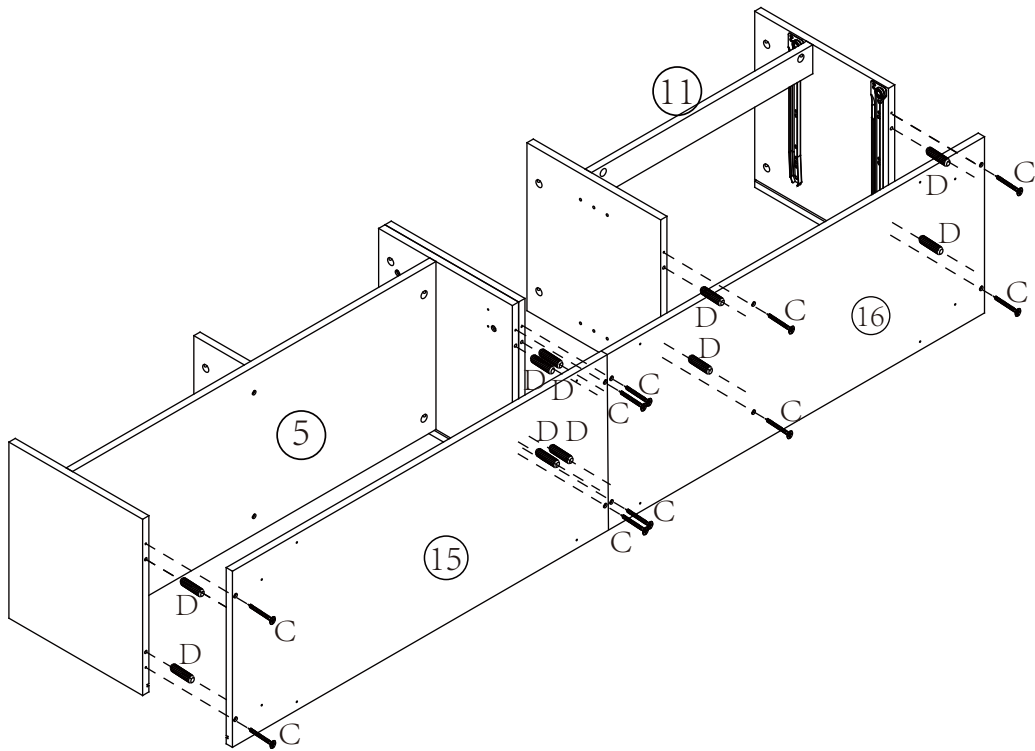
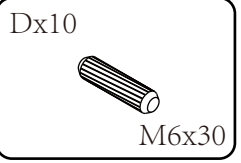
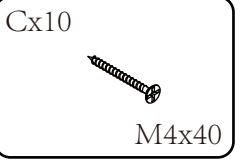

STEP 5

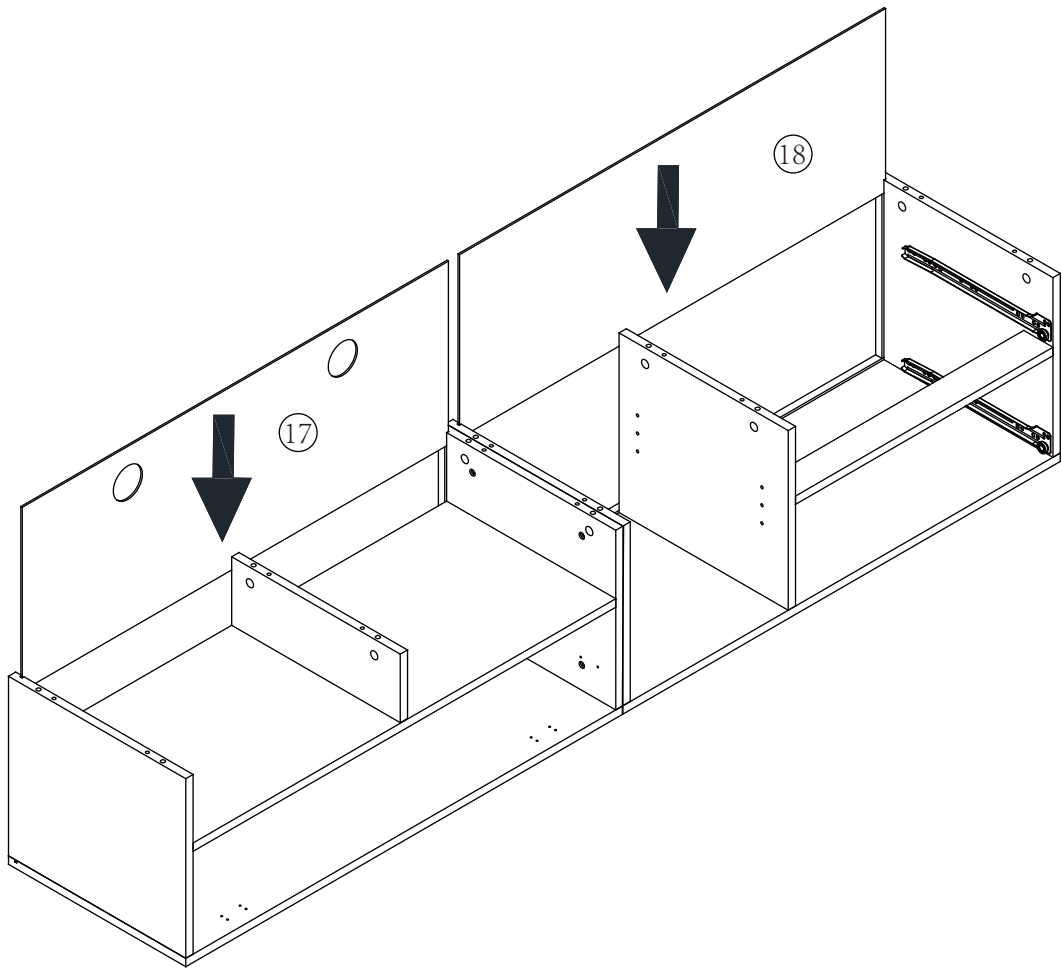

STEP 6

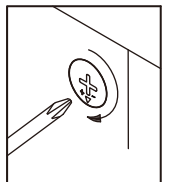
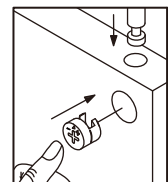
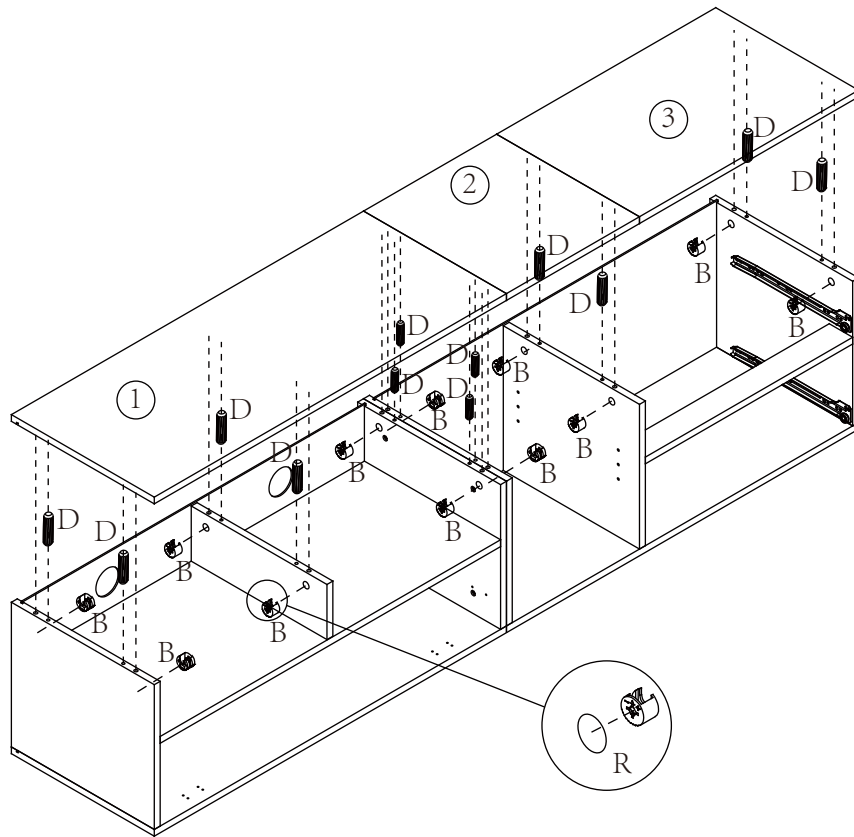
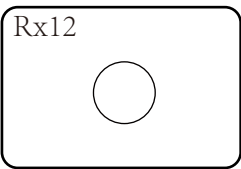
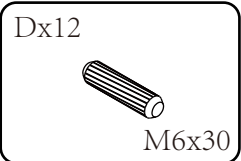

STEP 7

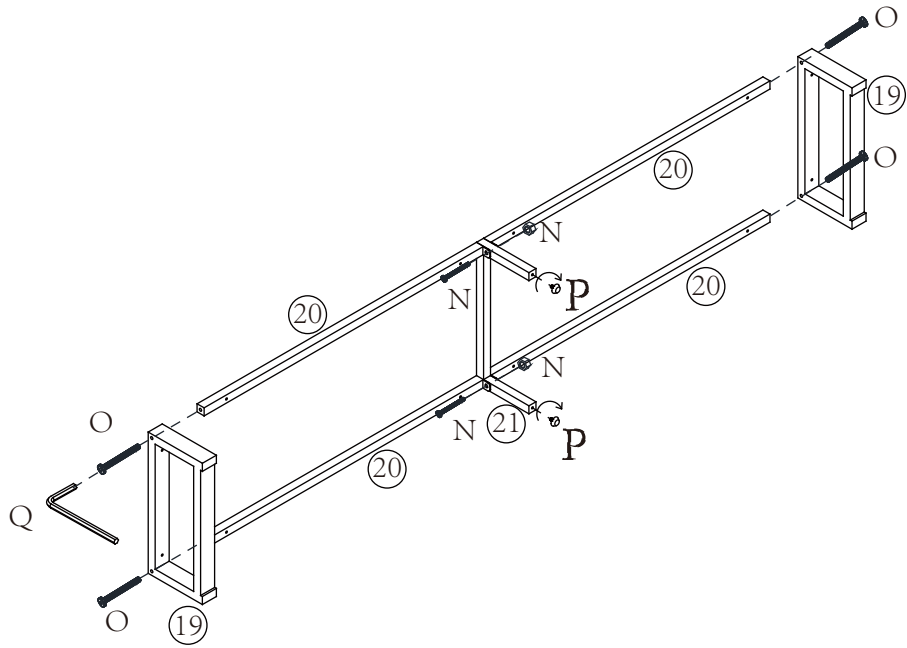
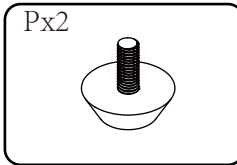
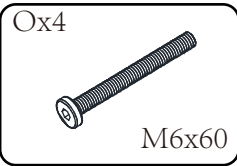
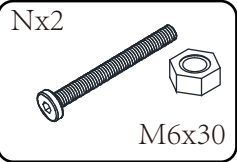

STEP 8

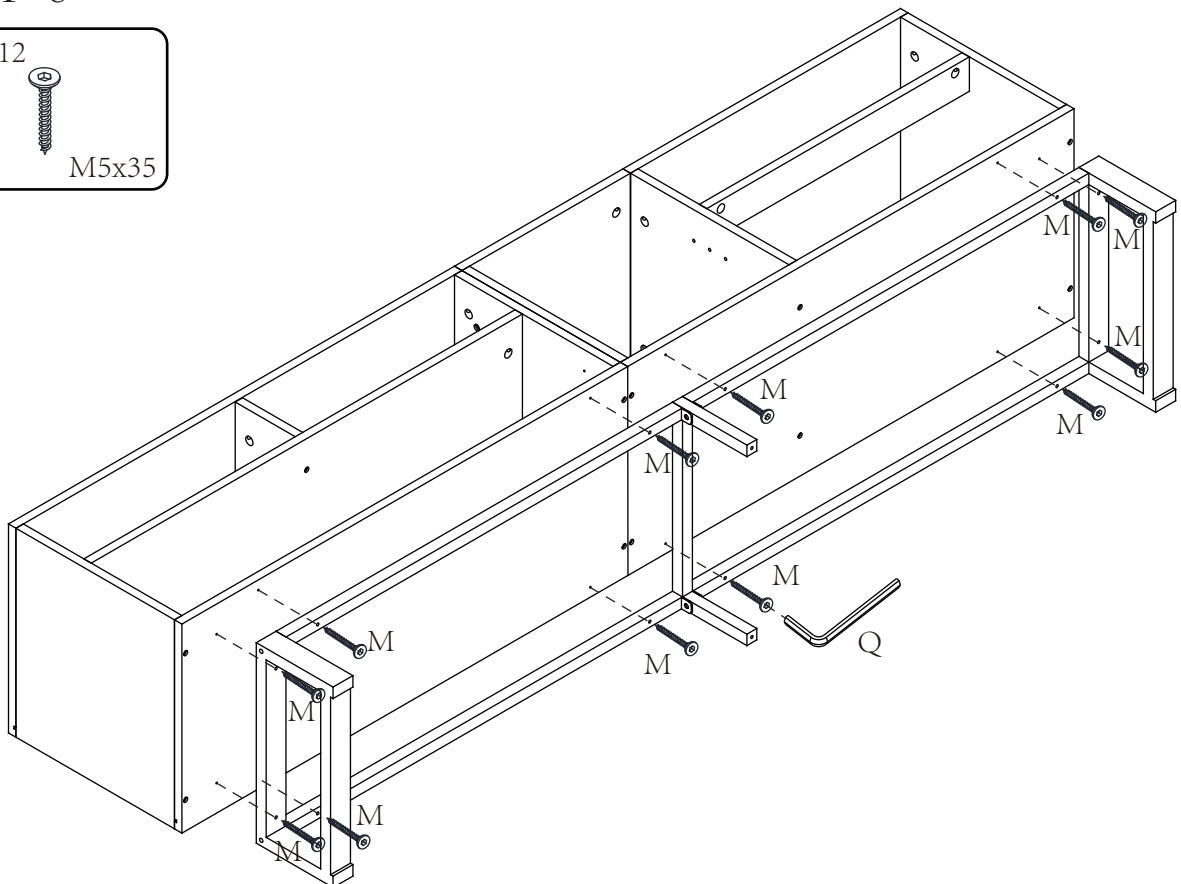
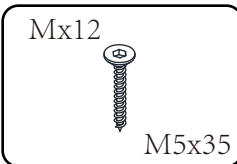

STEP 9

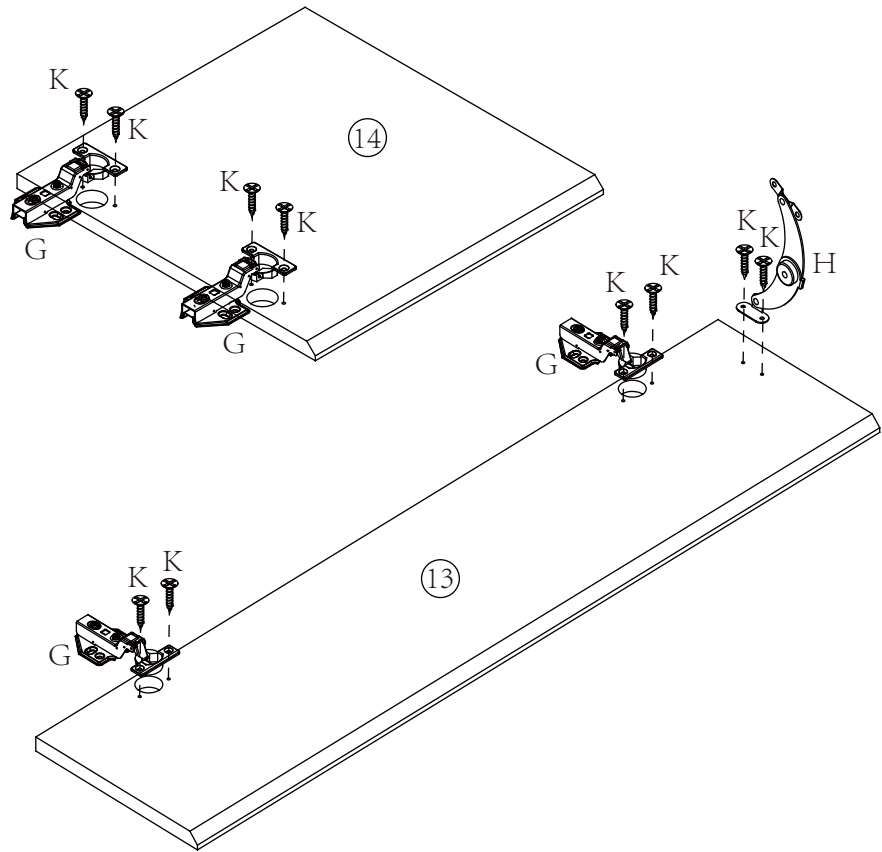
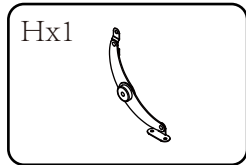
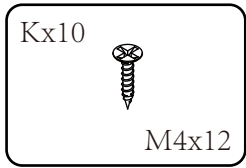
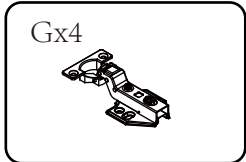

STEP 10

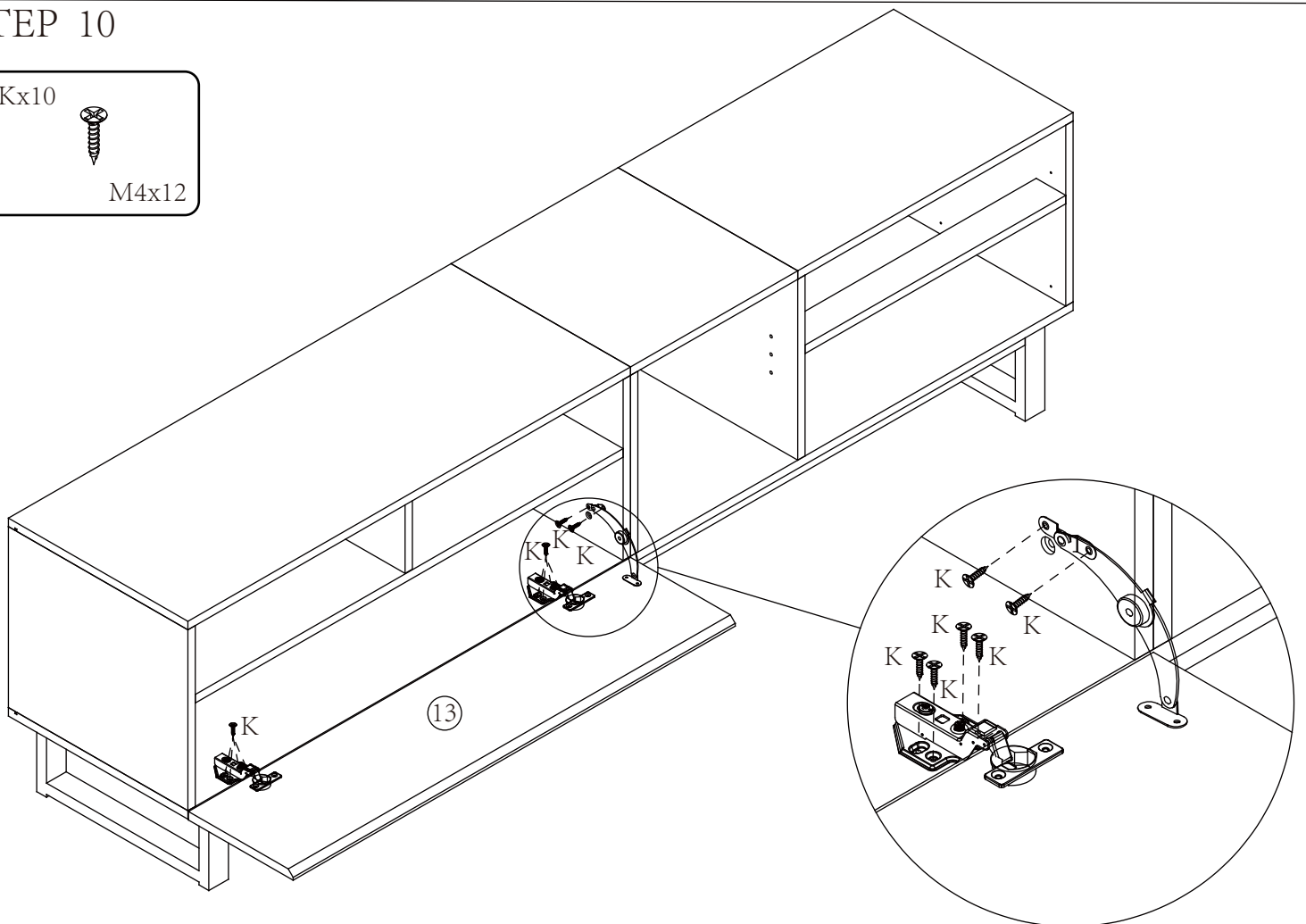
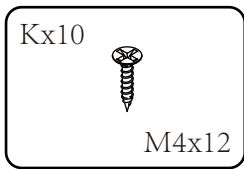

(For detailed hinge adjustment instructions, please refer to the last page.)

STEP 11

Jx4

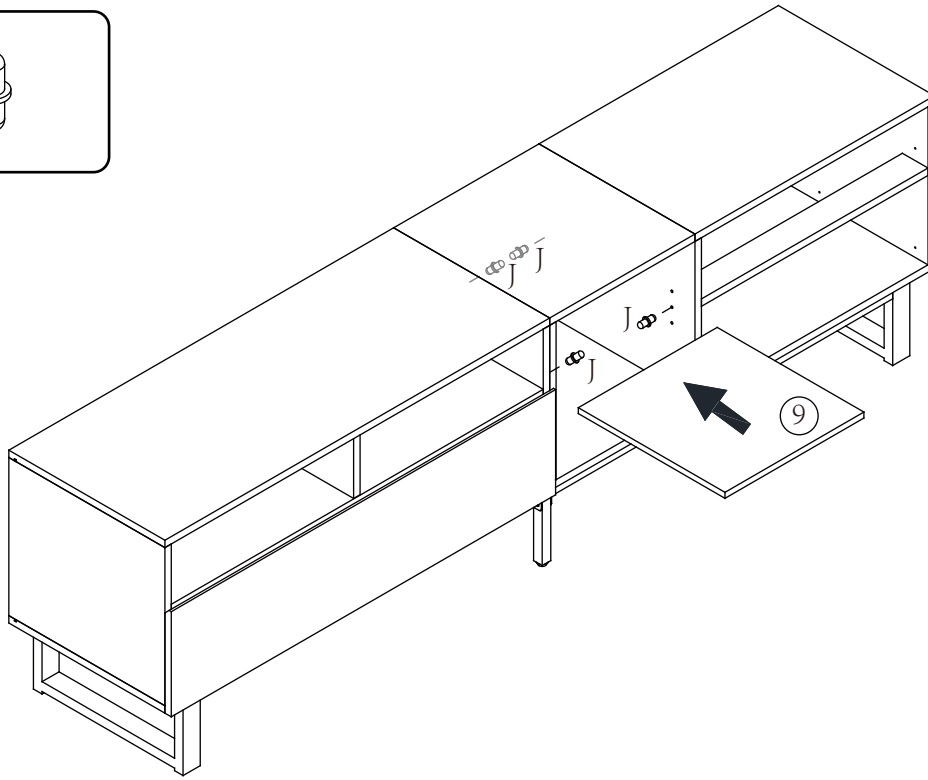

STEP 12

Kx8



M4x12

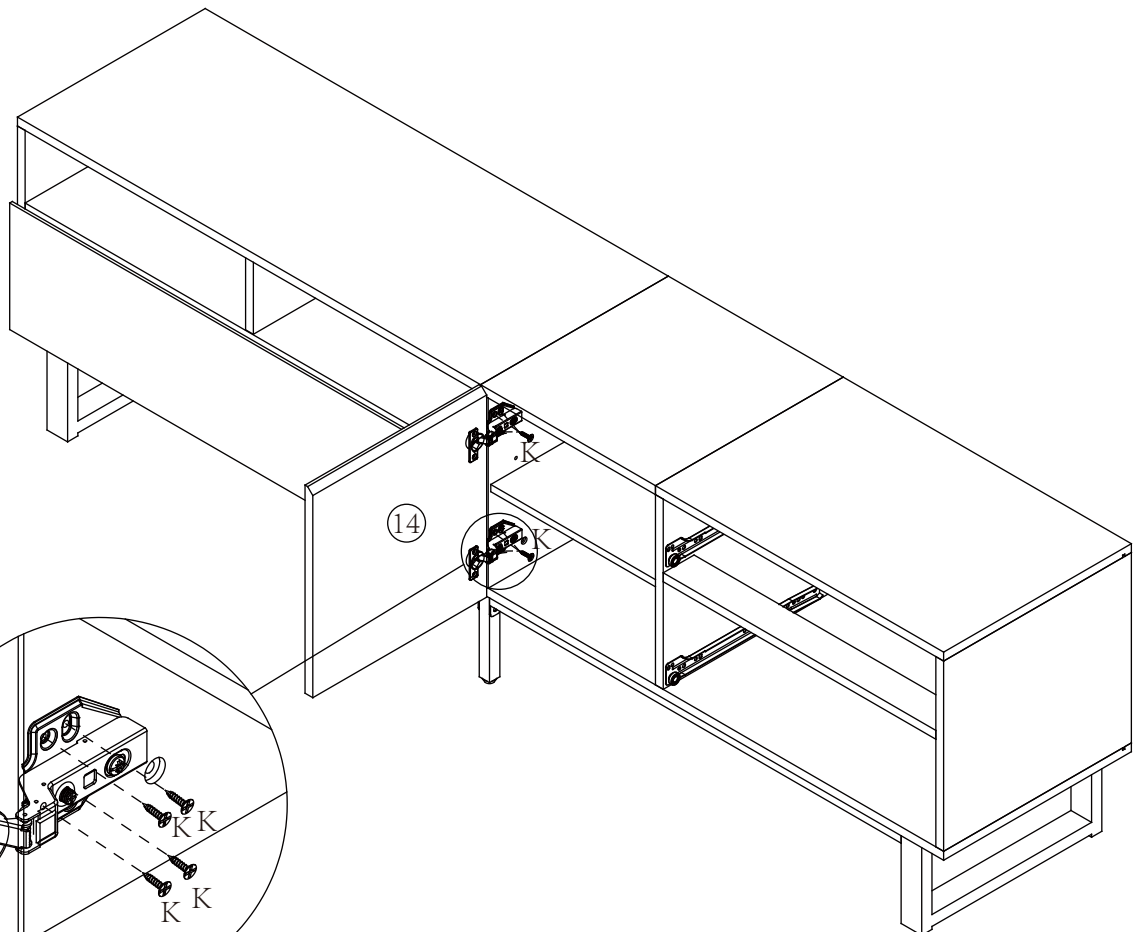
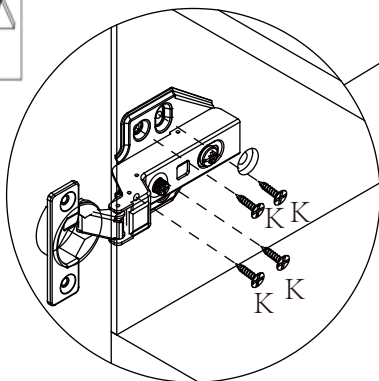
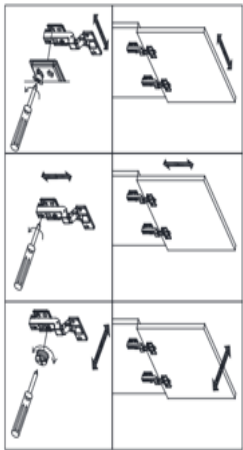

(For detailed hinge adjustment instructions, please refer to the last page.)

STEP 13

Ax10

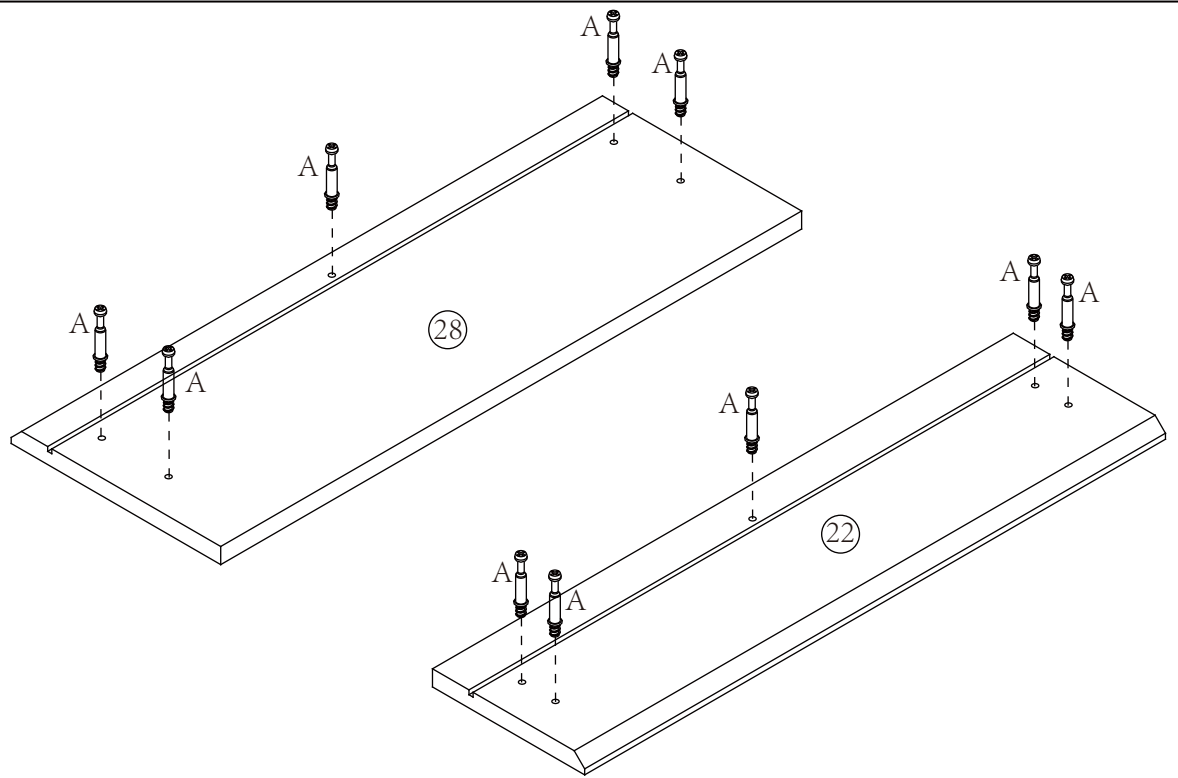

STEP 14

Ex10



M4x30

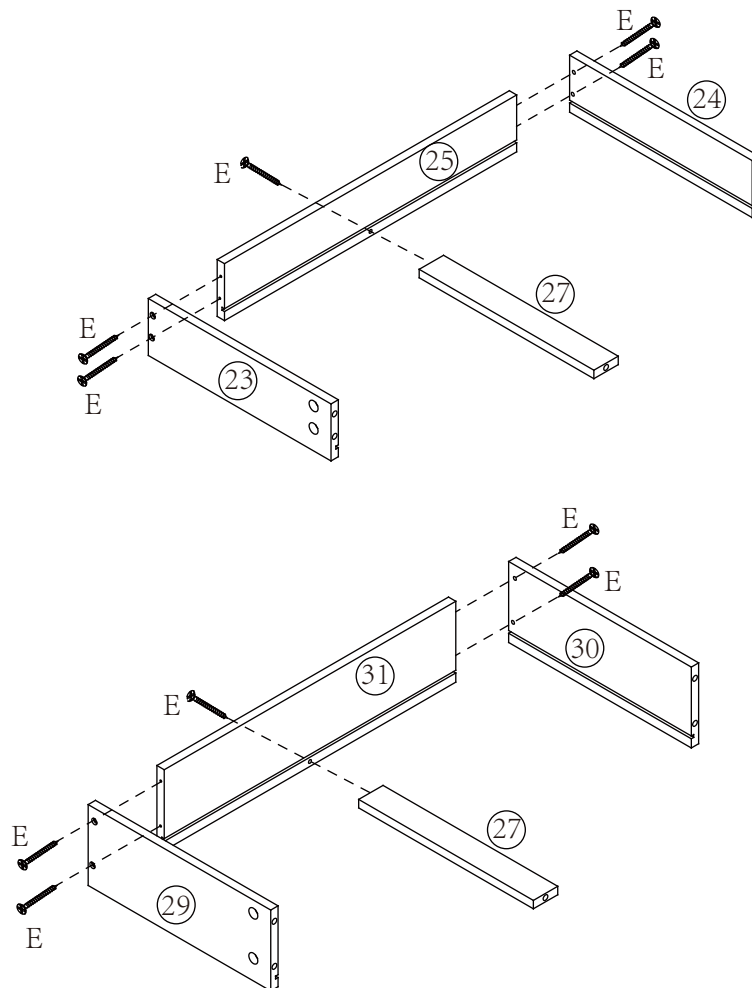

STEP 15

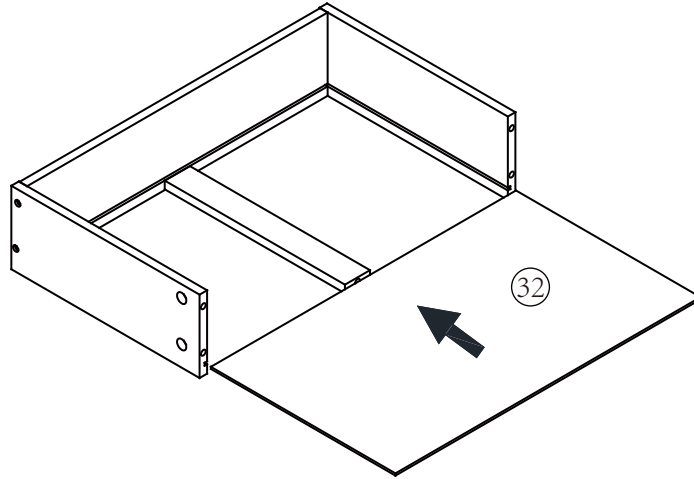
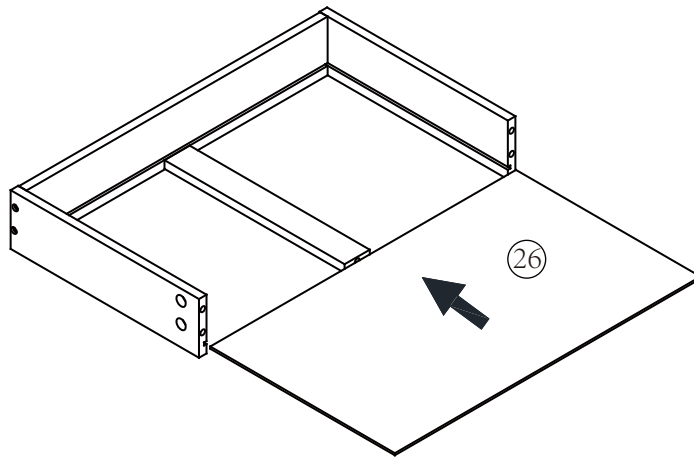

STEP 16

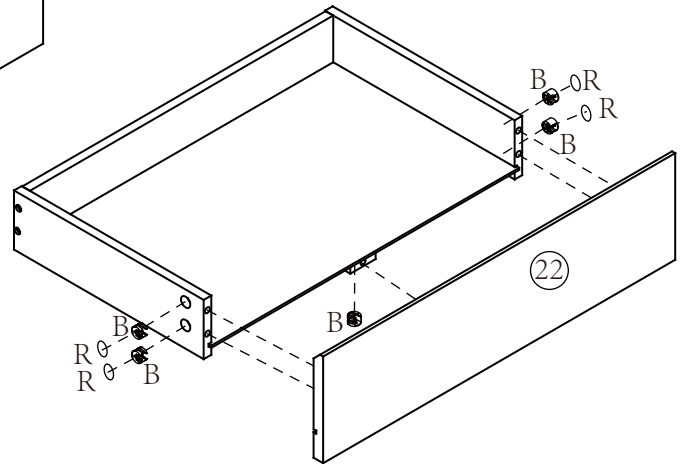
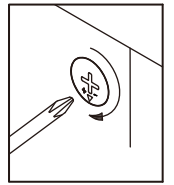
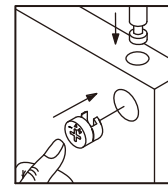
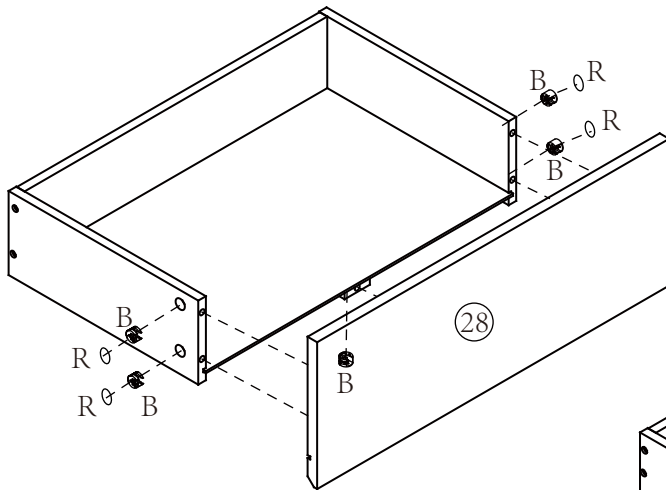

Rx8



Bx10



STEP 17

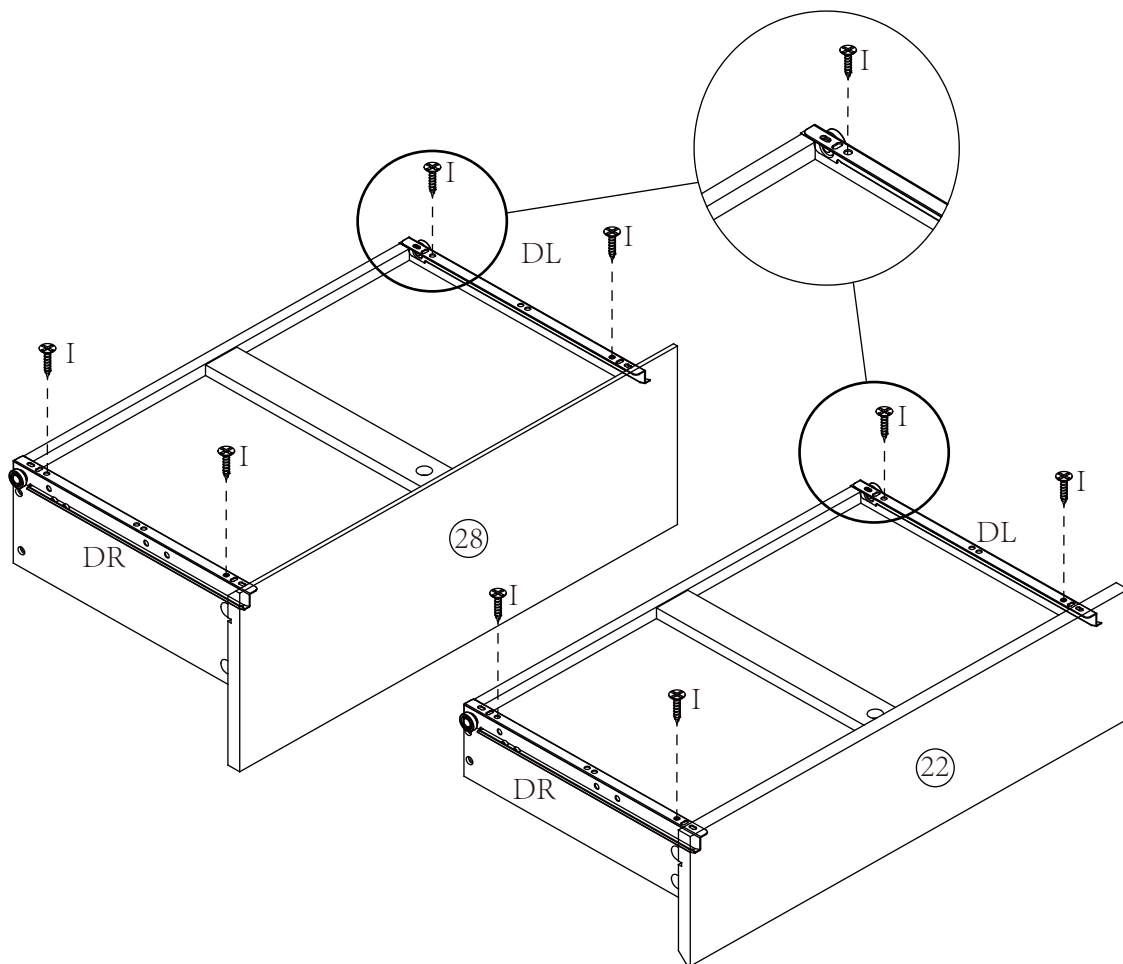
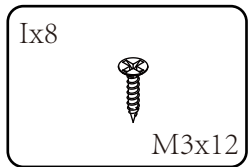
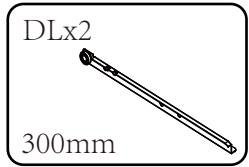
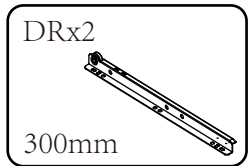

STEP 18

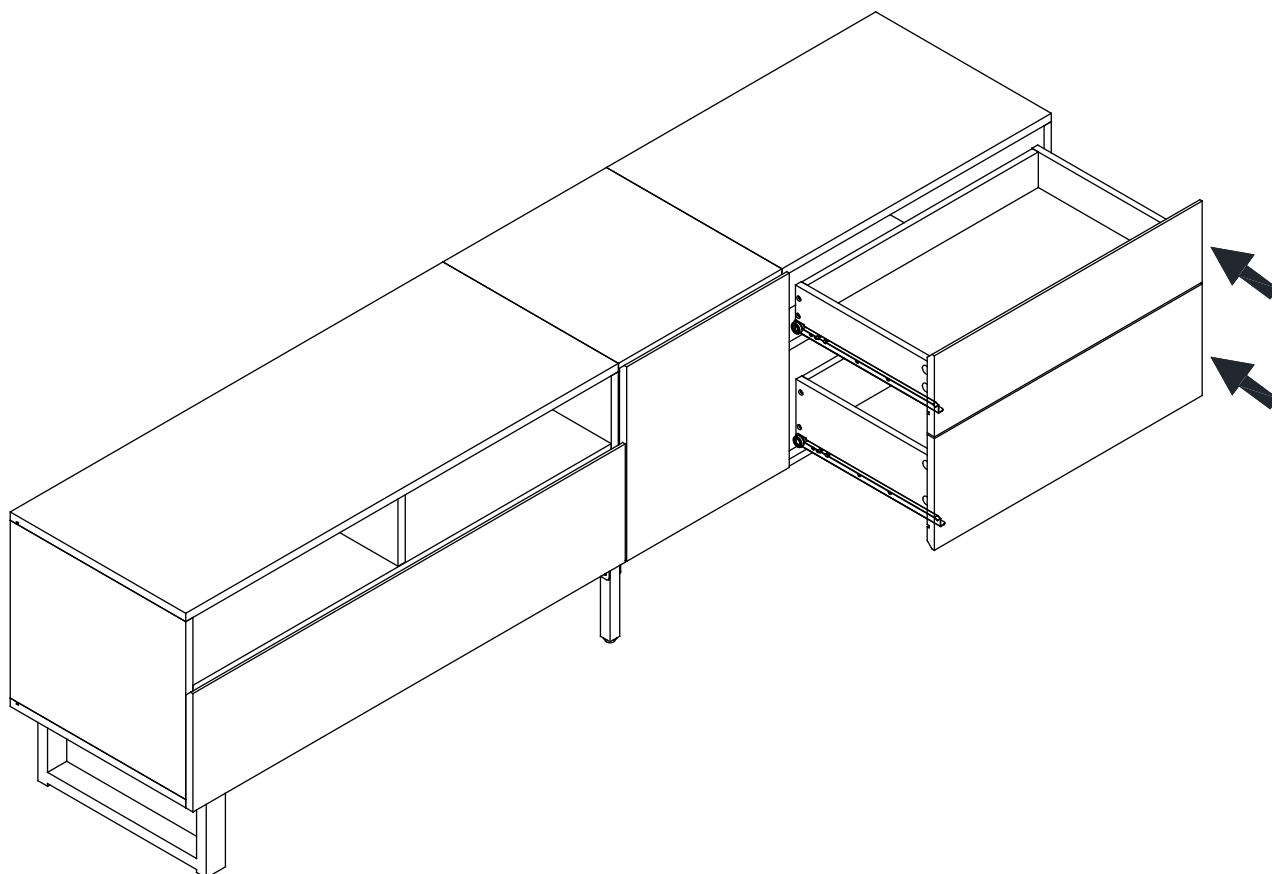

STEP 19

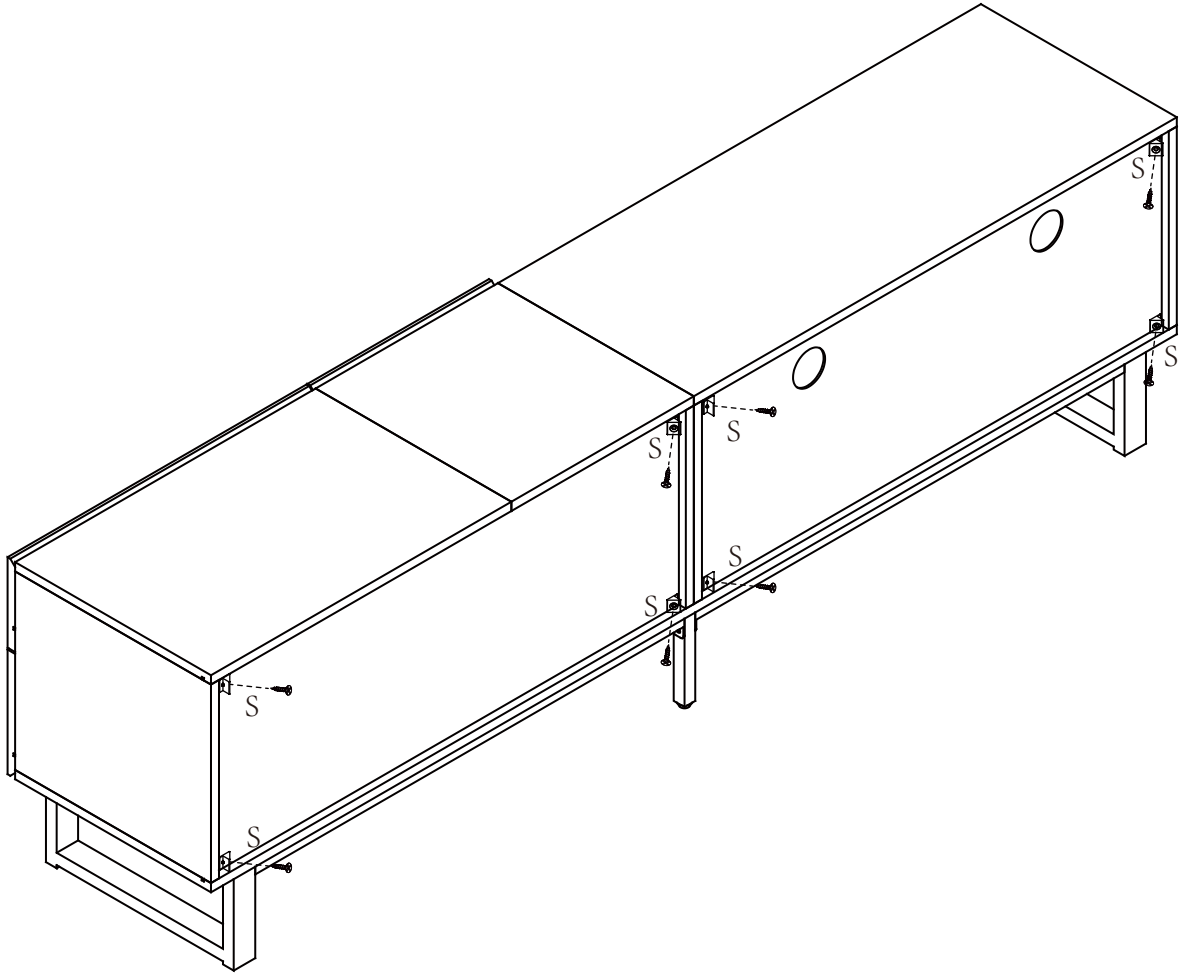

Sx8



HINGE ADJUSTMENTS

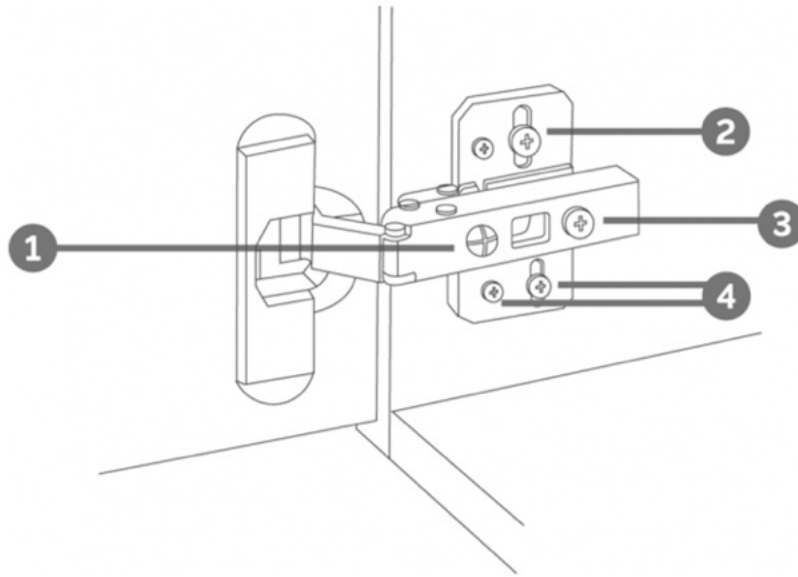

1 Sideways / Tilt adjustment

Turn the screw
clockwise to move the door further away from the side of the cabinet
anticlockwise to move the door closer to the side of the cabinet

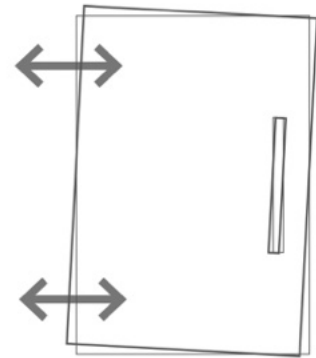

2 4 Height adjustment

While supporting the weight of the door, turn the screws
clockwise to move the door up
anticlockwise to move the door down

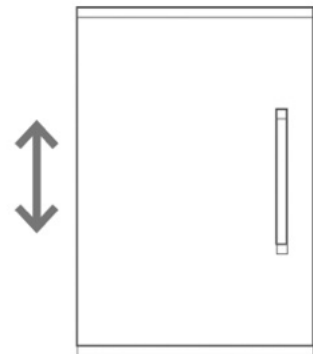

3 Forward and back adjustment

If the gap between the back of the door and the cabinet is too small, and the door may not close fully. Turn the screw
clockwise to decrease the gap between the door and the cabinet
anticlockwise to increase the gap between the door and the cabinet

