

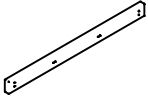











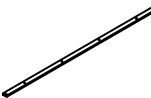
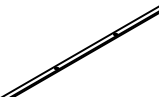
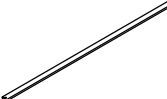



# K

## PART LIST

A	Headboard		1PC
B	Footboard		1PC
C	Legs		4PCS
D	Right Side rail		1PC
E	Left Side rail		1PC
F	Center Rail		2PCS
G	Slats Whit Hole		4PCS
H	Slats		8PCS
I	Center Rail Support		4PCS
J	Slat Support Legs		8PCS

## HARDWARE LIST

1	Bolt $\text{\O}5/16'' \times 1-3/16''$		8PCS
2	Bolt $\text{\O}1/4'' \times 2-1/4''$		16PCS
3	Screw M4 x 1-3/16''		28PCS
4	Lock Washer $\text{\O}5/16''$		8PCS
5	Flat Washer $\text{\O}5/16''$		8PCS
6	Lock Washer $\text{\O}1/4''$		16PCS
7	Flat Washer $\text{\O}1/4''$		16PCS
8	Allen Wrench M4		1PC
9	Anti Slip Sheet		4PCS

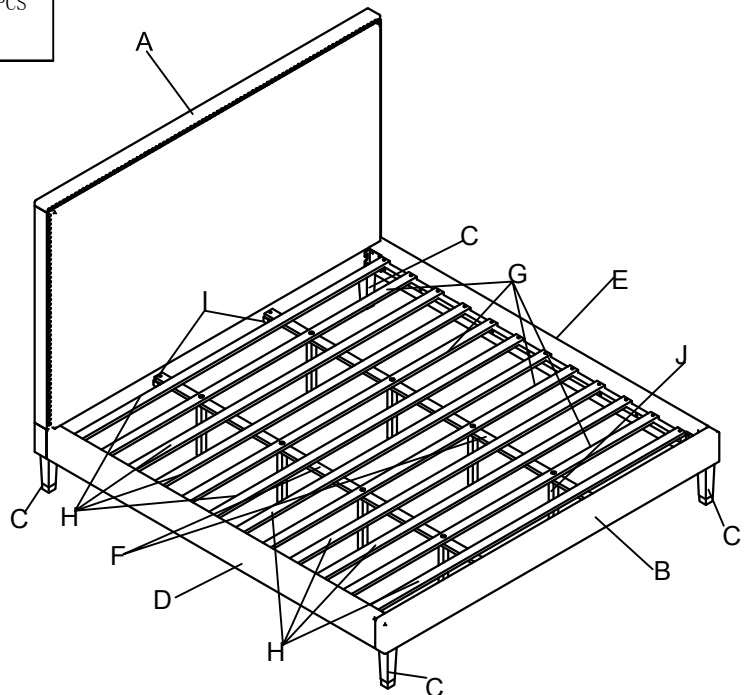

STEP 1

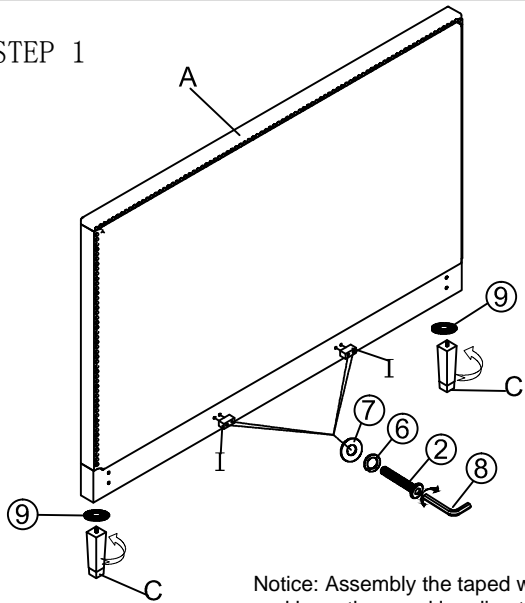

STEP 2

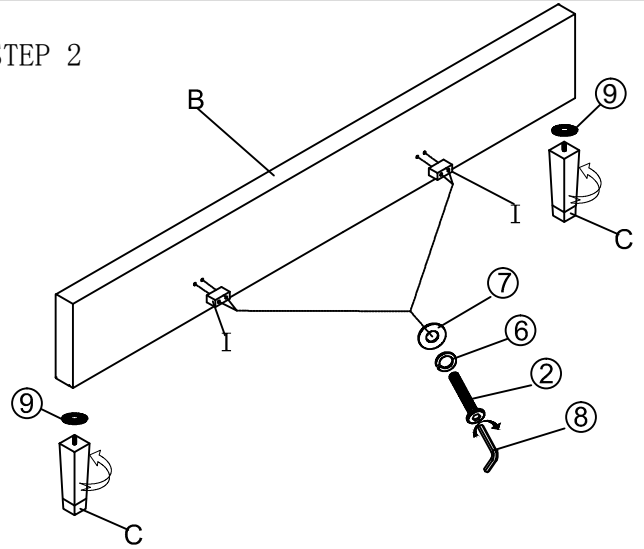

Notice: Assemble the taped wood leg with plastic ring into Headboard/Footboard bottom. Be tighten and keep the wood leg direction aline with headboard/Footboard. See illustration and Simple drawing.

STEP 3

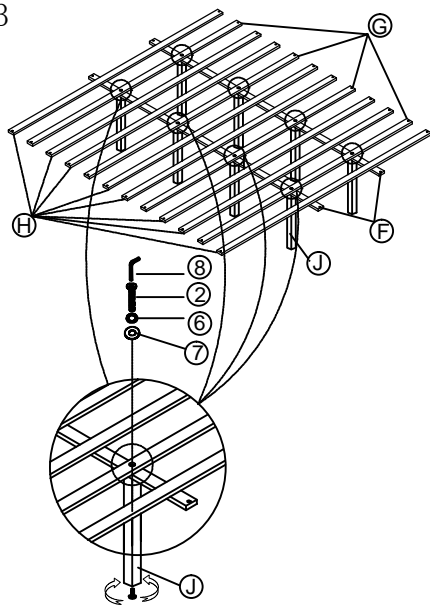

STEP 4

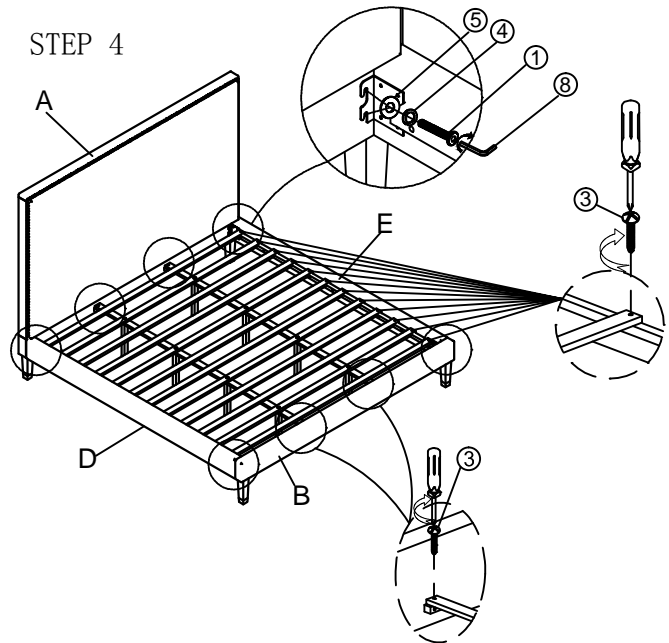

STEP 5

