

Front View

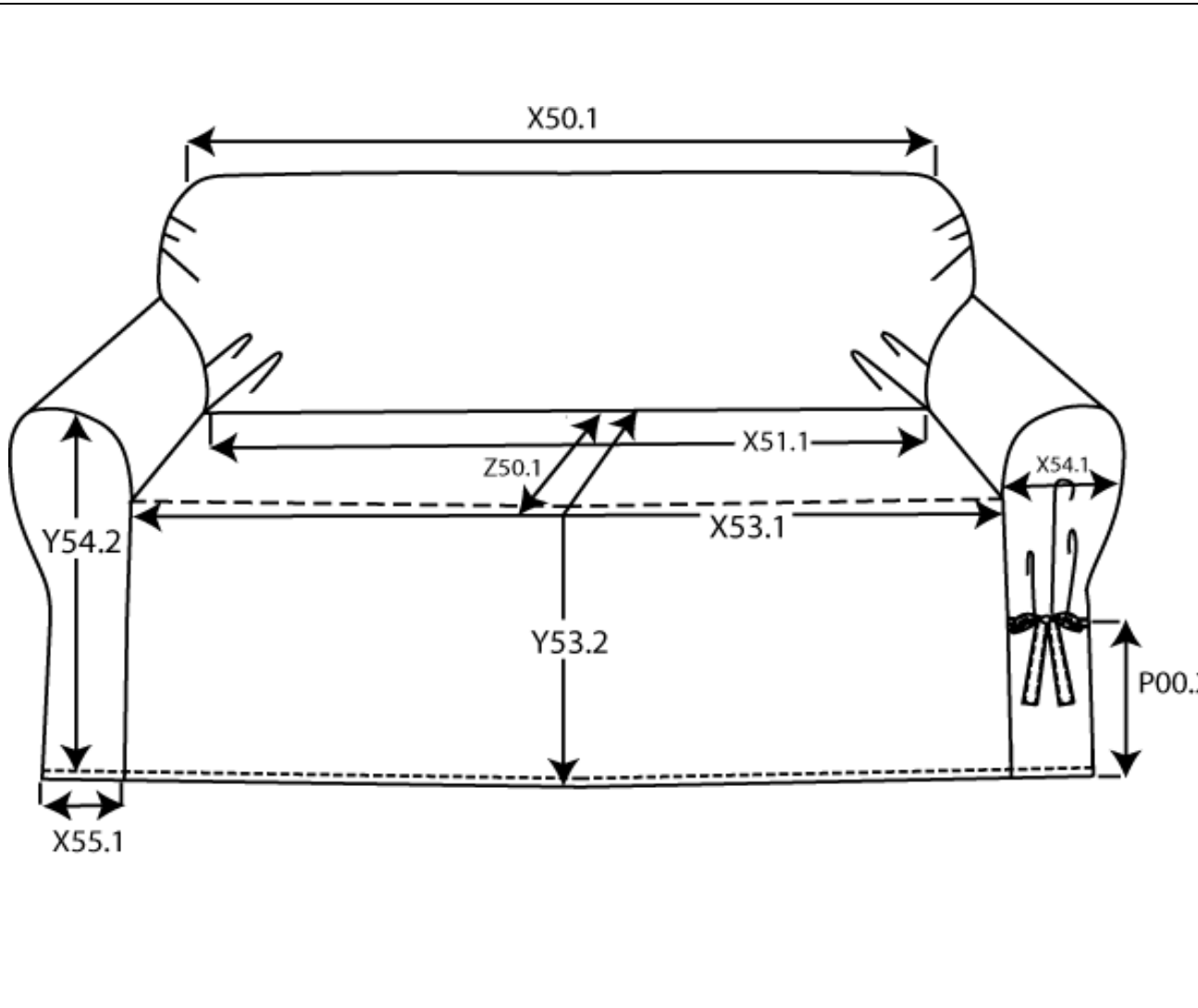

<p>X50.1 <u>Width – Slipcover across top</u> Measure seam to seam across top seam. Measurement does not include binding, ruffle, flange, fringe or piping.</p>
<p>X51.1 <u>Width – Slipcover seat seam</u> Measure seam to seam at seat seam. Measurement does not include binding, ruffle, flange, fringe or piping.</p>
<p>X53.1 <u>Width – Slipcover seat at front</u> Measure seam to seam at front. Measurement does not include binding, ruffle, flange, fringe or piping.</p>
<p>X54.1 <u>Width – Slipcover arm</u> Measure seam to seam at widest point. Measurement does not include binding, ruffle, flange, fringe or piping.</p>
<p>X55.1 <u>Width – Slipcover arm at hem</u> Measure seam to seam at hem. Measurement does not include binding, ruffle, flange, fringe or piping.</p>
<p>P00.2 <u>Placement – Tie</u> Measure edge to tie center. Measurement includes binding, ruffle, flange, fringe or piping.</p>
<p>Y53.2 <u>Length – Slipcover total front</u> Measure seat seam to front hem at center. Measurement includes binding, ruffle, flange, fringe or piping.</p>
<p>Y54.2 <u>Length – Slipcover arm height</u> Measure seam to hem at center front. Measurement includes binding, ruffle, flange, fringe or piping.</p>
<p>Z50.1 <u>Depth – Slipcover seat</u> Measure seam to seam at center. Measurement does not include binding, ruffle, flange, fringe or piping.</p>

Back View

<p>The diagram shows the back view of a garment with a tie. Four measurement lines are indicated: X52.1 (width across the back), Y51.2 (length from shoulder seam to hem), X02.2 (width of the tie), and Y02.2 (length of the tie).</p>	<p>X52.1 <u>Width – Slipcover outer back</u> Measure seam to seam at hem. Measurement does not include binding, ruffle, flange, fringe or piping.</p>
	<p>Y51.2 <u>Length – Slipcover back to hem</u> Measure seam to hem at center back. Measurement includes binding, ruffle, flange, fringe or piping.</p>
	<p>X02.2 <u>Width – Tie</u> Measure edge to edge. Measurement includes binding, ruffle, flange, fringe or piping.</p>
	<p>Y02.2 <u>Length - Tie</u> Measure seam to end. Measurement includes binding, ruffle, flange, fringe or piping.</p>

Other Views

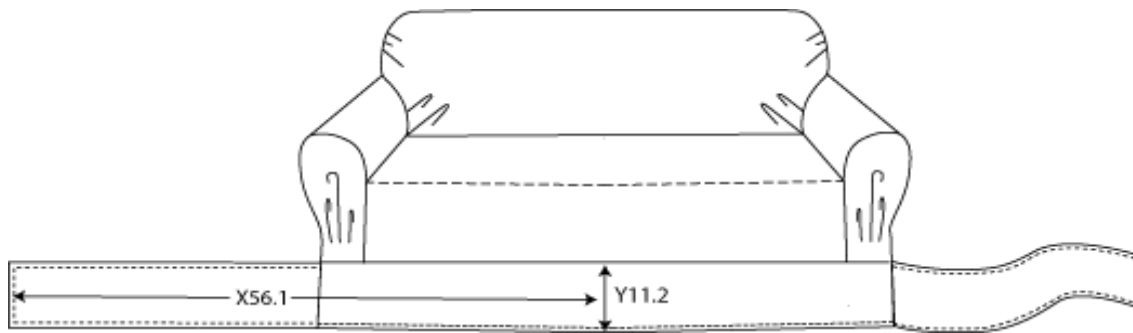

X56.1

Width – Slipcover wrap skirt
Measure center front to end at center.
Measurement includes binding, ruffle, flange, fringe or piping.

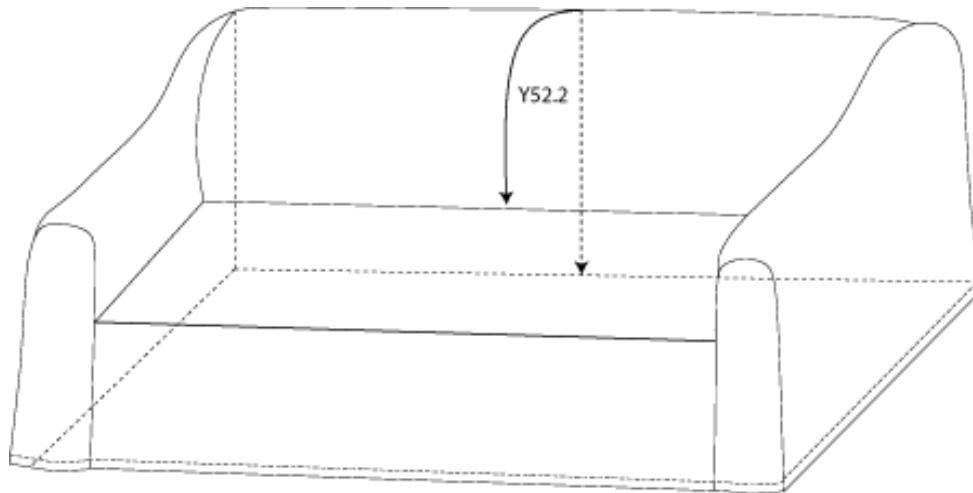

Y11.2

Length - Drop
Measure seam to edge at center.
Measurement includes binding, ruffle, flange, fringe or piping.

Y52.2

Length – Slipcover total back
Measure seat seam to back hem at center.
Measurement does not include binding, ruffle, flange, fringe or piping.

Other Views

<p>The diagram shows a perspective view of a pocket on a rectangular piece of fabric. The overall width of the fabric is labeled X12.1. The length of the pocket opening is labeled Y12.1. The depth of the pocket from the top edge to the bottom of the pocket opening is labeled Z10.1. The distance from the top edge of the pocket opening to the center of the tie is labeled P00.2. The width of the tie is labeled X02.2. The length of the tie is labeled Y02.2. The diagram also shows a curved pocket opening and a straight pocket opening, both with their respective measurements.</p>	<p>X12.1 <u>Width – Fitted Pocket</u> Measure pocket seam to pocket seam. Measurement does not include binding, ruffle, flange, fringe or piping.</p>
	<p>Y12.1 <u>Length – Fitted Pocket</u> Measure pocket seam to pocket seam. Measurement does not include binding, ruffle, flange, fringe or piping.</p>
	<p>Z10.1 <u>Depth – Corner pocket</u> Measure pocket seam from edge to point. Measurement does not include binding, ruffle, flange, fringe or piping.</p>
	<p>P00.2 <u>Placement – Tie</u> Measure edge to tie center. Measurement includes binding, ruffle, flange, fringe or piping.</p>
	<p>X02.2 <u>Width – Tie</u> Measure edge to edge. Measurement includes binding, ruffle, flange, fringe or piping.</p>
	<p>Y02.2 <u>Length - Tie</u> Measure seam to end. Measurement includes binding, ruffle, flange, fringe or piping.</p>