

# Assembly Instructions

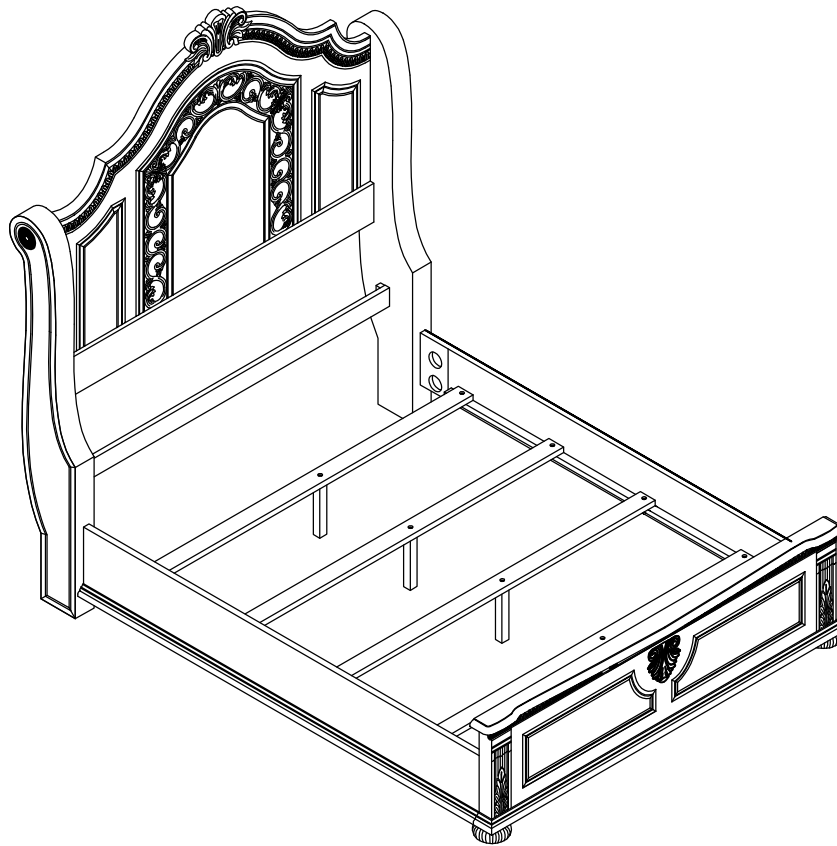

## ASSEMBLY RATING

The Assembly Rating is a 5-point system that shows the degree of effort needed in assembling a specific product (with 1 being easy and 5 being difficult). For some products, two persons are recommended.

EASY  DIFFICULT

## Tools Required For Assembly:

Allen Wrench

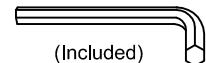

(Included)

Wrench

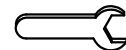

(Included)

Phillips Screwdriver



(Not Included)

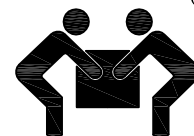

2 PERSONS RECOMMENDED

# ASSEMBLY & CARE ADVICE

FOR YOUR FURNITURE TO LAST, CORRECT ASSEMBLY AND PROPER MAINTENANCE ARE NECESSARY. PLEASE FOLLOW THE INFORMATION PROVIDED BELOW TO FULLY ENJOY YOUR FURNITURE.

## BASIC ASSEMBLY TECHNIQUES



When lock or spring washer is used in an assembly, please make sure the lock or spring washer is placed between the larger flat washer and the head of the screw or bolt.



Position each part correctly and insert screws or bolts into their respective holes by hand tighten or using the proper hand tool. Only tighten when step is completed or when instructed to do so.



Use cardboard or carpet area when assembling furniture to prevent scratches. Make sure the furniture rests on a flat and level surface with each leg evenly touching the floor.



Some furniture comes with height adjustment knobs underneath each leg. To lower or to raise each leg, you need to turn clockwise or counterclockwise, respectively.



Make sure all parts are properly aligned, then use the appropriate hand tool to completely tighten the bolts or screws. Do not use power tools and do not overtighten.



Save the instructions and store the Allen wrench or any supplied tool for later maintenance. After two weeks, check and tighten any loose hardware and repeat again every six months thereafter.

IT IS THE USER'S RESPONSIBILITY TO MAINTAIN THE FURNITURE. THE HARDWARE MAY LOOSEN OVER TIME AND MAY CAUSE THE FURNITURE TO BE WOBBLY AND UNABLE TO SUPPORT ITS INTENDED WEIGHT CAPACITY. THIS MAY LEAD TO COLLAPSE AND MAY CAUSE SERIOUS INJURY.

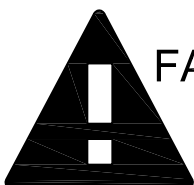





**FAILURE TO FOLLOW THE GUIDELINES ABOVE MAY RESULT IN INJURY AND/OR PROPERTY DAMAGE.**







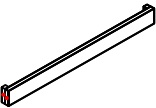
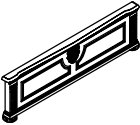
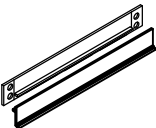
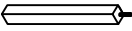

Before you begin, please read Page 2 of "Assembly and Care Advice".

And remember, do not tighten until each step is completed or instructed.

### Parts List

	#1 x 1pc Headboard Panel
	#2 x 2pcs Leg (L & R)
	#3 x 1pc Cross Bar
	#4 x 1pc Footboard
	#5 x 2pcs Bed Rail
	#6 x 4pcs $\text{Ø}1/4"$ Support Leg 30x30x230mm
	#7 x 4pcs Bed Slat

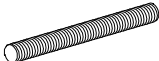
### Hardware List

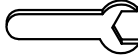
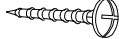
	#A x 8pcs Bolt $\text{Ø}5/16"$ X 1-3/4"
	#B x 8pcs Spring Washer $\text{Ø}5/16"$
	#C x 8pcs Flat Washer $\text{Ø}5/16"$
	#D x 1pc Allen Wrench M4
	#E x 8pcs Thread Bolt $\text{Ø}5/16"$ *4"
	#F x 8pcs Half Moon $\text{Ø}5/16"$
	#G x 8pcs Hex Nut $\text{Ø}5/16"$
	#H x 1pc Wrench 12mm
	#I x 8pcs Wood Screw #4x1-1/4"



1) Align leg (#2L) and crossbar (#3) to the holes of the headboard panel (#1). Prepare 4 bolts assemblies by inserting lock washer (#B), then flat washer (#C) to bolts (#A).  
Secure with bolts (#A) by using an Allen wrench (#D).

#A x 8pcs  
#B x 8pcs  
#C x 8pcs

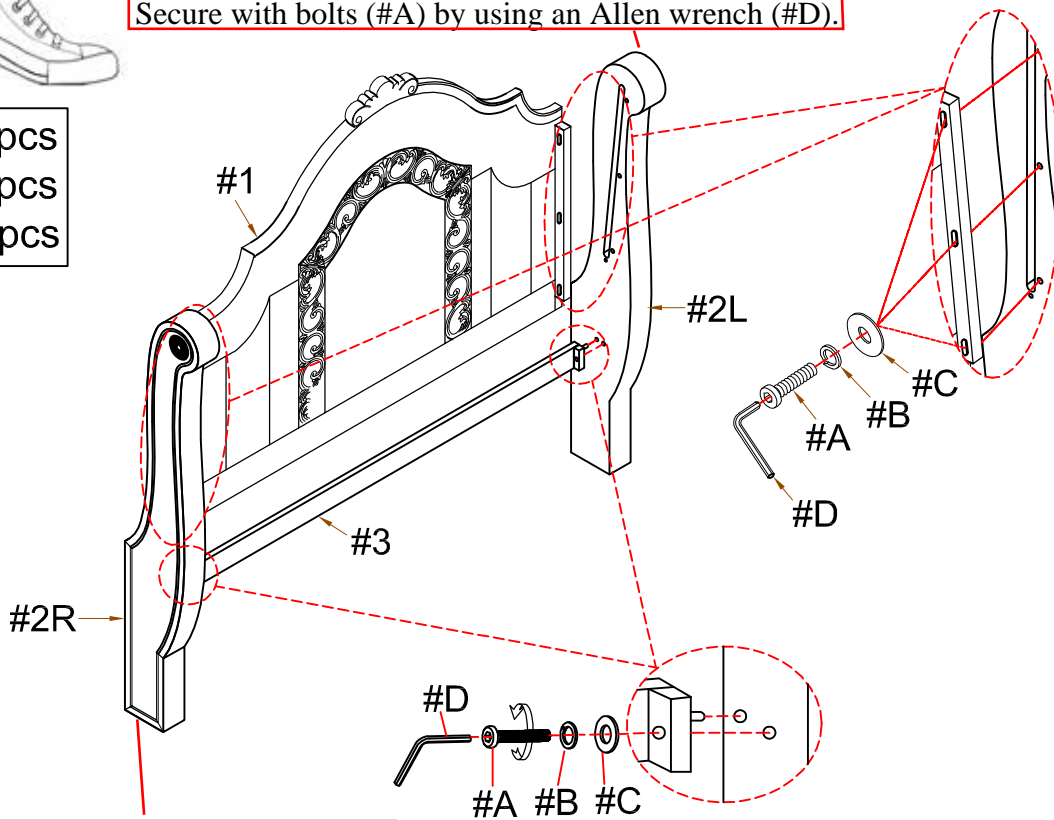

2) Do the same as step 1 to leg (#2R).



Attach thread bolts (#E) to headboard (#1) and footboard (#4). Align bed rails (#5) to headboard (#1) and footboard (#4). Secure with hex nuts (#G) by using a wrench (#H).

#E x 8pcs  
#F x 8pcs  
#G x 8pcs

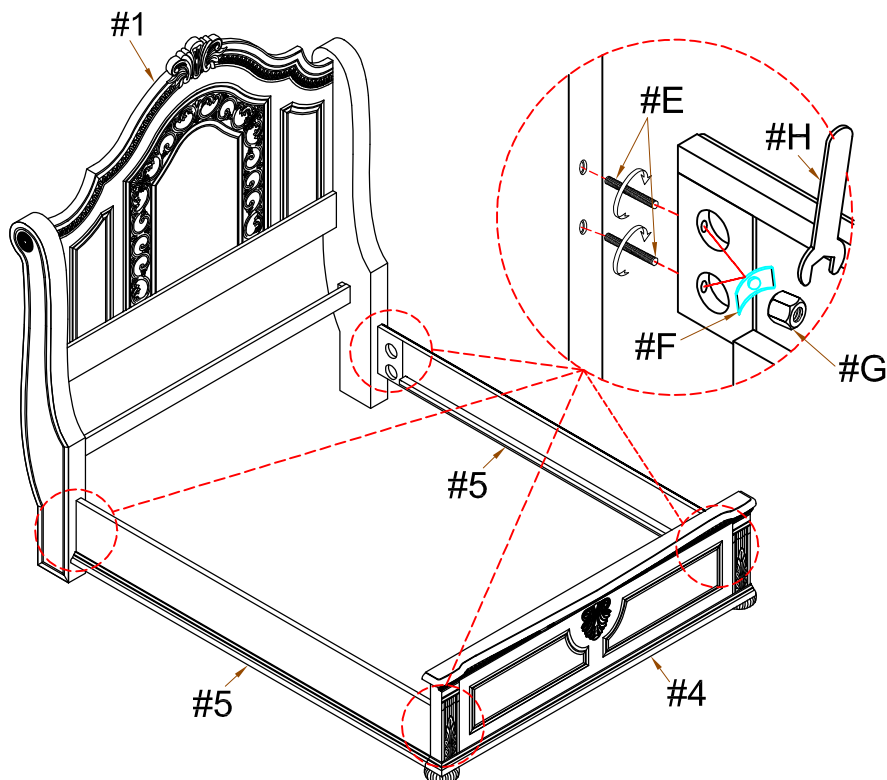

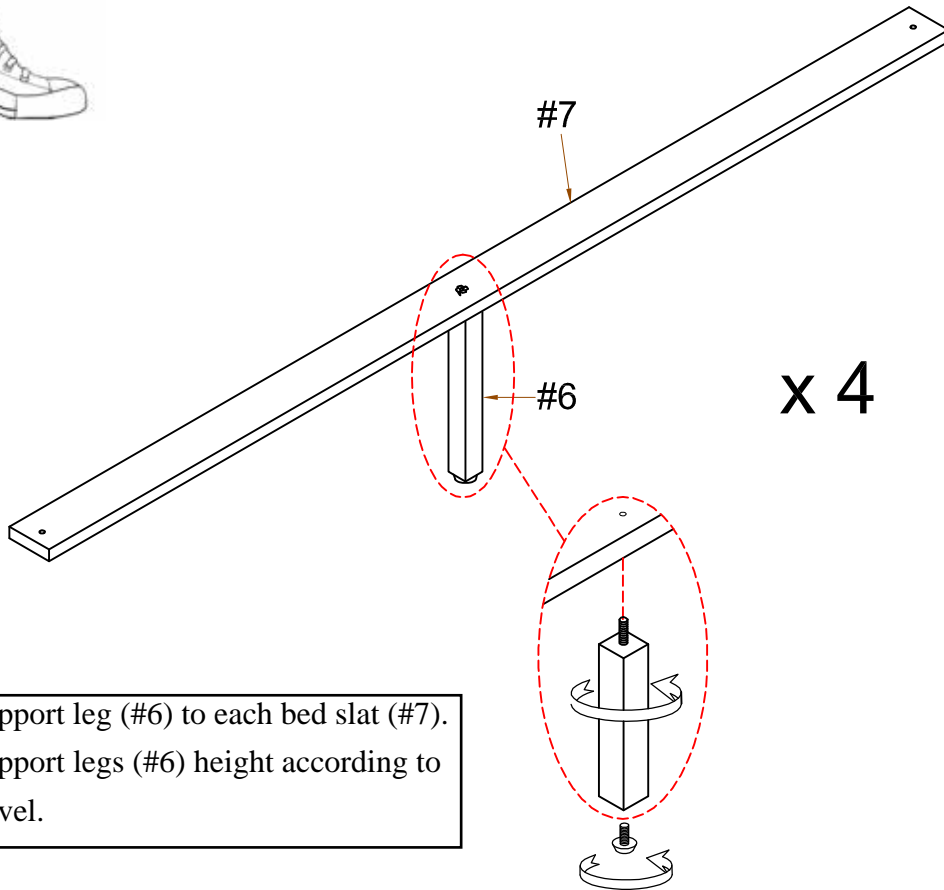

Attach support leg (#6) to each bed slat (#7).  
Adjust support legs (#6) height according to ground level.



Align bed slats (#7) to the holes of the bed rails (#5).  
Secure with wood screw (#1) by using a screwdriver.

#1 x 8pcs

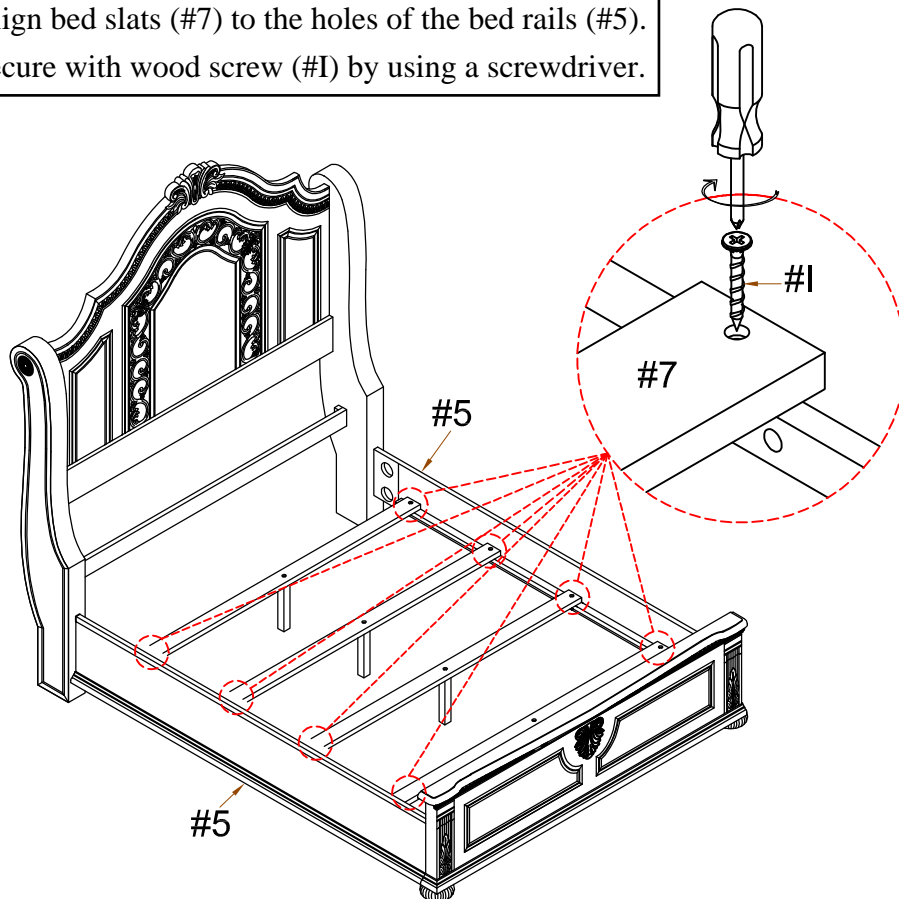

ASSEMBLY IS COMPLETED

# Assembly Instructions

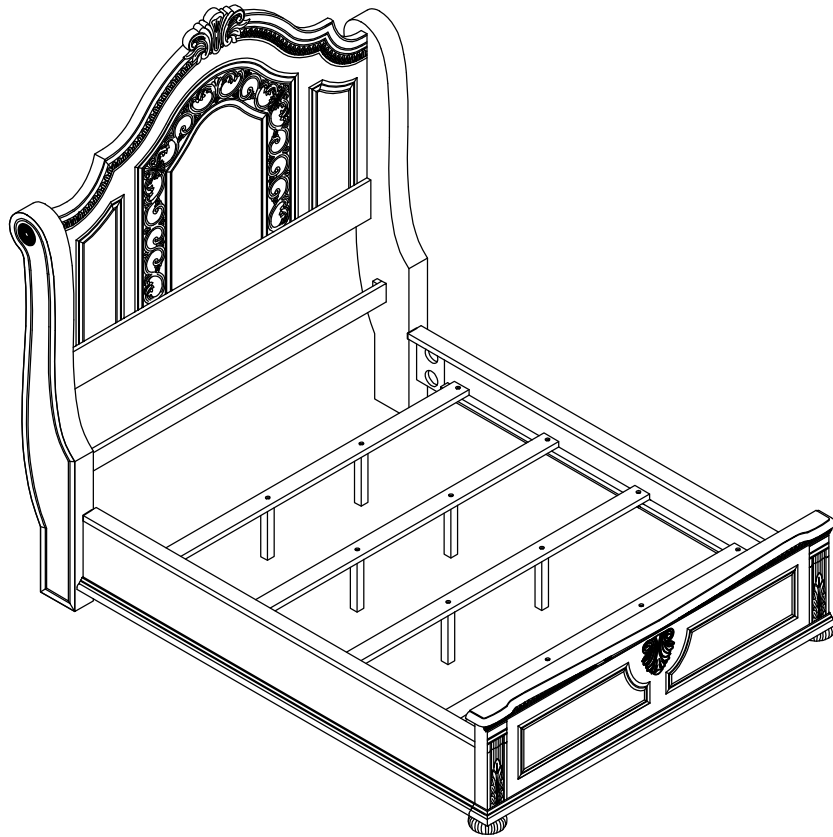

## ASSEMBLY RATING

The Assembly Rating is a 5-point system that shows the degree of effort needed in assembling a specific product (with 1 being easy and 5 being difficult). For some products, two persons are recommended.

EASY



DIFFICULT

## Tools Required For Assembly:

Allen Wrench

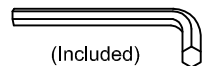

(Included)

Wrench

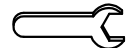

(Included)

Phillips Screwdriver



(Not Included)



2 PERSONS RECOMMENDED

# ASSEMBLY & CARE ADVICE

FOR YOUR FURNITURE TO LAST, CORRECT ASSEMBLY AND PROPER MAINTENANCE ARE NECESSARY. PLEASE FOLLOW THE INFORMATION PROVIDED BELOW TO FULLY ENJOY YOUR FURNITURE.

## BASIC ASSEMBLY TECHNIQUES

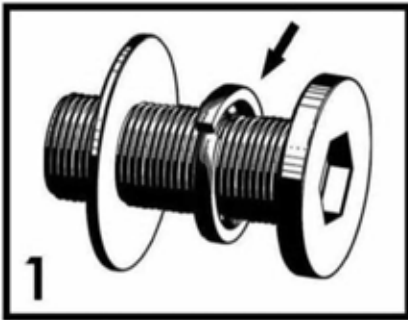

When lock or spring washer is used in an assembly, please make sure the lock or spring washer is placed between the larger flat washer and the head of the screw or bolt.



Position each part correctly and insert screws or bolts into their respective holes by hand tighten or using the proper hand tool. Only tighten when step is completed or when instructed to do so.

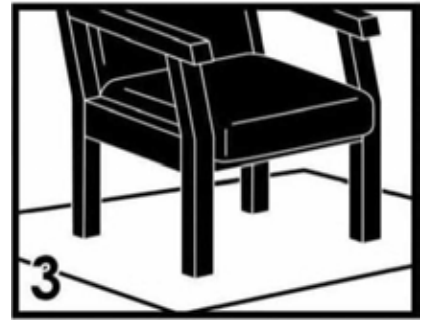

Use cardboard or carpet area when assembling furniture to prevent scratches. Make sure the furniture rests on a flat and level surface with each leg evenly touching the floor.

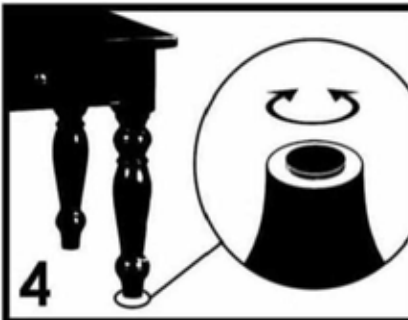

Some furniture comes with height adjustment knobs underneath each leg. To lower or to raise each leg, you need to turn clockwise or counterclockwise, respectively.

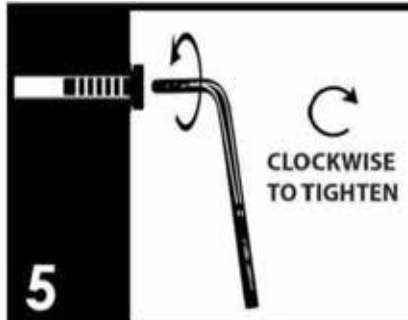

Make sure all parts are properly aligned, then use the appropriate hand tool to completely tighten the bolts or screws. Do not use power tools and do not overtighten.

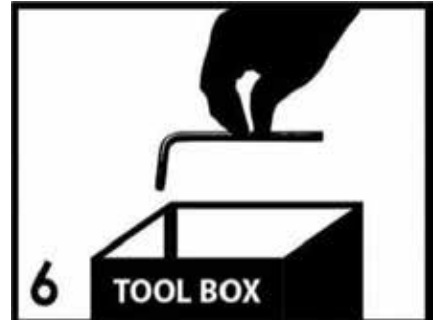

Save the instructions and store the Allen wrench or any supplied tool for later maintenance. After two weeks, check and tighten any loose hardware and repeat again every six months thereafter.

IT IS THE USER'S RESPONSIBILITY TO MAINTAIN THE FURNITURE. THE HARDWARE MAY LOOSEN OVER TIME AND MAY CAUSE THE FURNITURE TO BE WOBBLY AND UNABLE TO SUPPORT ITS INTENDED WEIGHT CAPACITY. THIS MAY LEAD TO COLLAPSE AND MAY CAUSE SERIOUS INJURY.

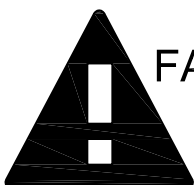





**FAILURE TO FOLLOW THE GUIDELINES ABOVE MAY RESULT IN INJURY AND/OR PROPERTY DAMAGE.**







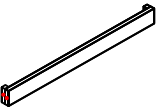
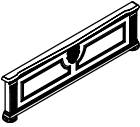
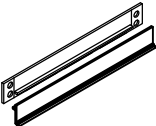
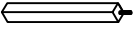

Before you begin, please read Page 2 of "Assembly and Care Advice".

And remember, do not tighten until each step is completed or instructed.

### Parts List

	#1 x 1pc Headboard Panel
	#2 x 2pcs Leg (L & R)
	#3 x 1pc Cross Bar
	#4 x 1pc Footboard
	#5 x 2pcs Bed Rail
	#6 x 8pcs $\text{Ø}1/4"$ Support Leg 30x30x230mm
	#7 x 4pcs Bed Slat

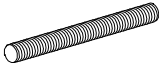
### Hardware List

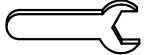
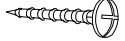
	#A x 8pcs Bolt $\text{Ø}5/16"$ X 1-3/4"
	#B x 8pcs Spring Washer $\text{Ø}5/16"$
	#C x 8pcs Flat Washer $\text{Ø}5/16"$
	#D x 1pc Allen Wrench M4
	#E x 8pcs Thread Bolt $\text{Ø}5/16"$ *4"
	#F x 8pcs Half Moon $\text{Ø}5/16"$
	#G x 8pcs Hex Nut $\text{Ø}5/16"$
	#H x 1pc Wrench 12mm
	#I x 8pcs Wood Screw #4x1-1/4"



1) Align leg (#2L) and crossbar (#3) to the holes of the headboard panel (#1). Prepare 4 bolts assemblies by inserting lock washer (#B), then flat washer (#C) to bolts (#A). Secure with bolts (#A) by using an Allen wrench (#D).

#A x 8pcs  
#B x 8pcs  
#C x 8pcs

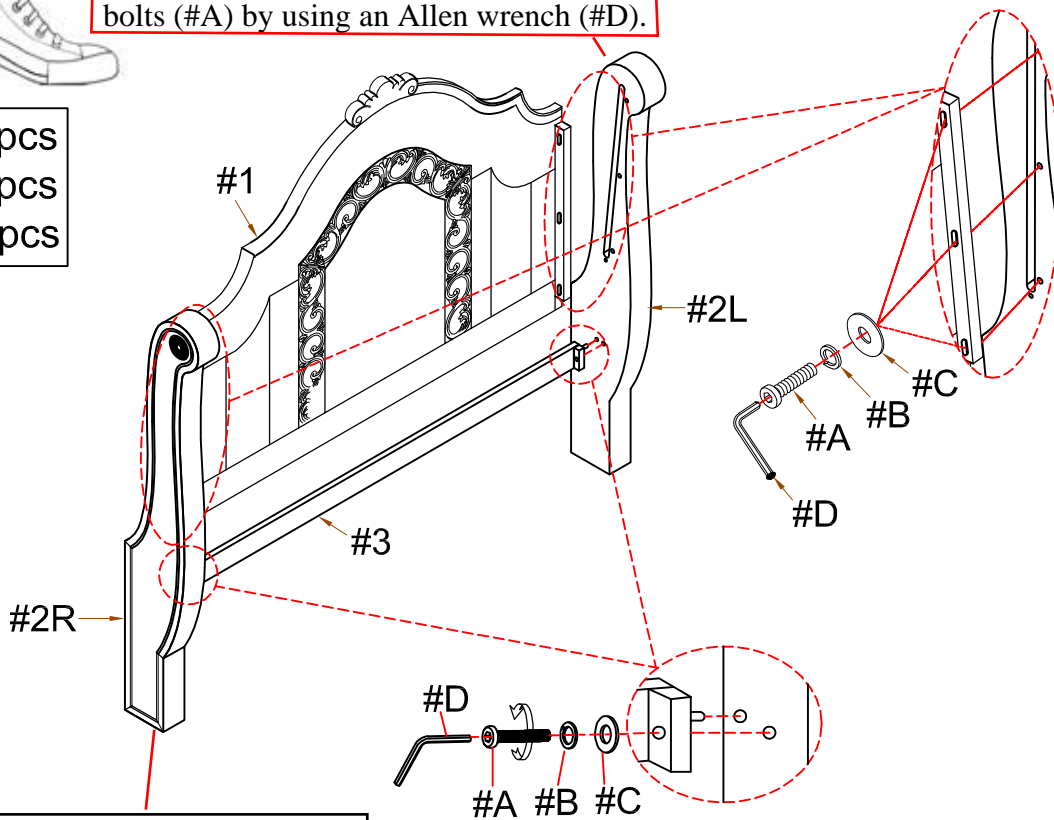

2) Do the same as step 1 to leg (#2R)



Attach thread bolts (#E) to headboard (#1) and footboard (#4). Align bed rails (#5) to headboard (#1) and footboard (#4). Secure with hex nuts (#G) by using a wrench (#H).

#E x 8pcs  
#F x 8pcs  
#G x 8pcs

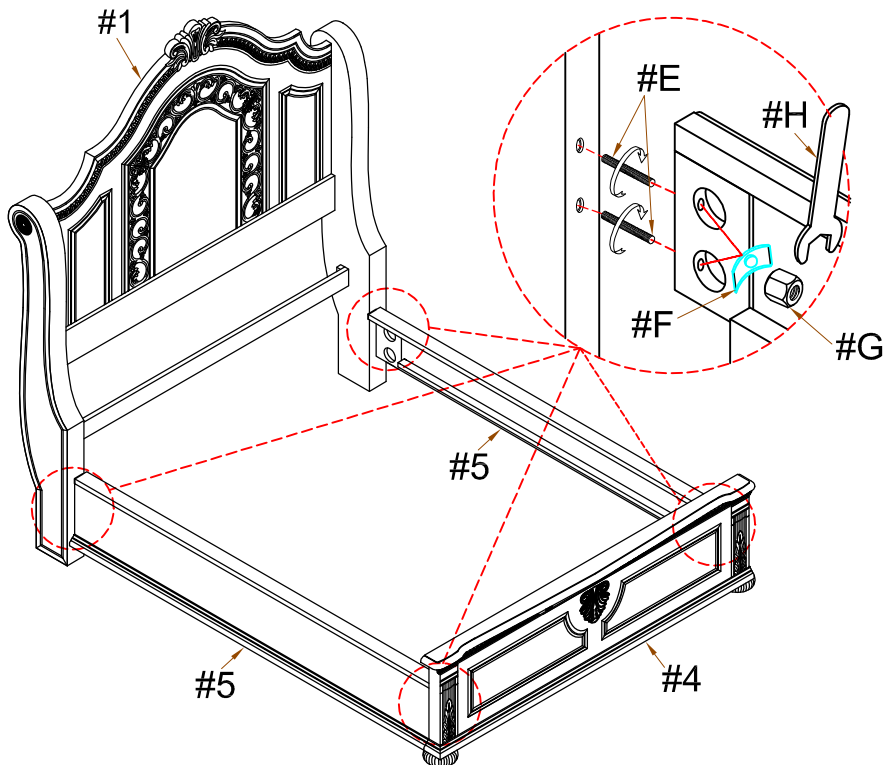

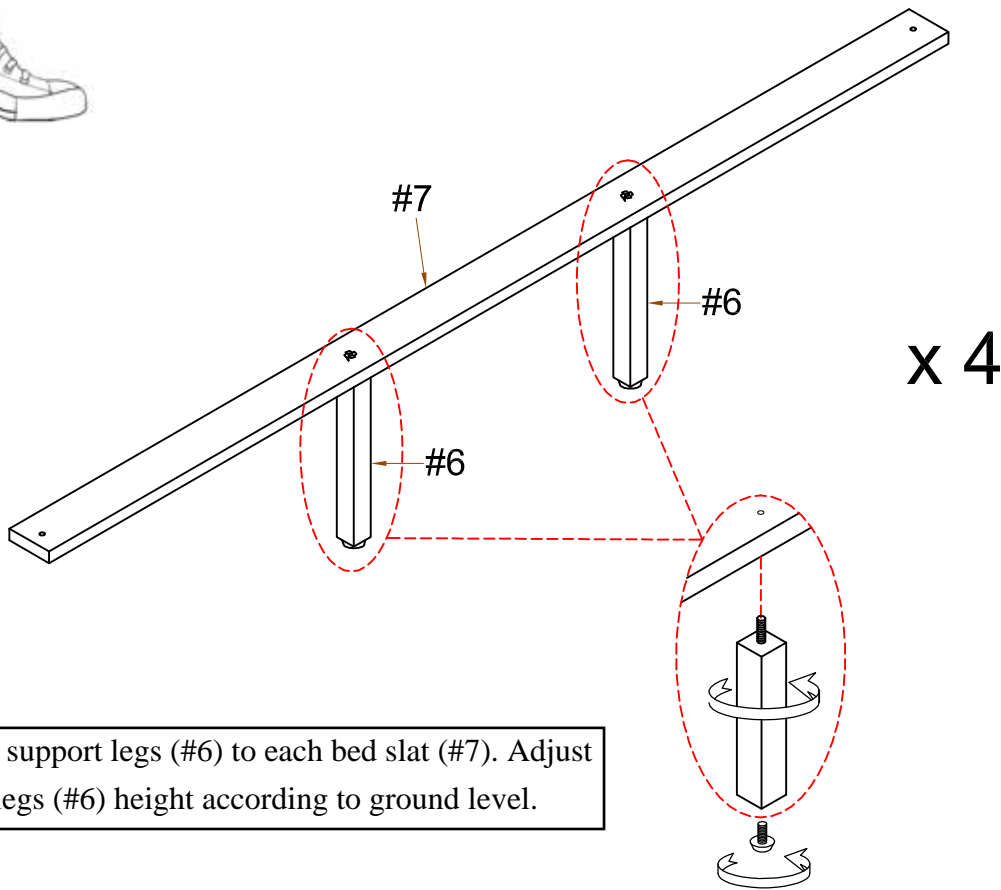

Attach 2 support legs (#6) to each bed slat (#7). Adjust support legs (#6) height according to ground level.



Align bed slats (#7) to the holes of the bed rails (#5). Secure with wood screw (#1) by using a screwdriver.

#1 x 8pcs

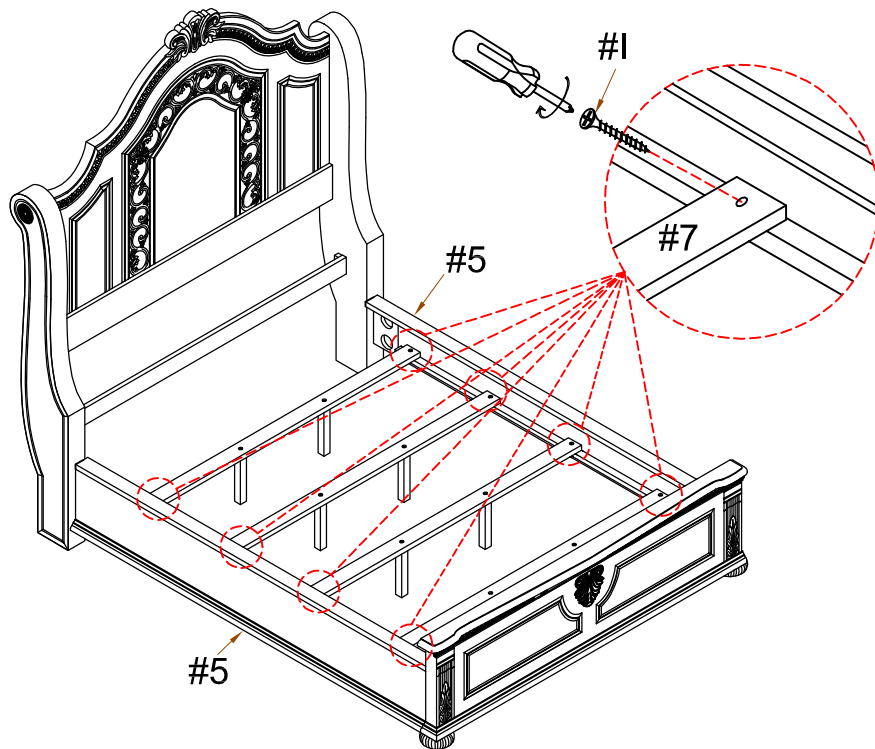

ASSEMBLY IS COMPLETED

# Assembly Instructions

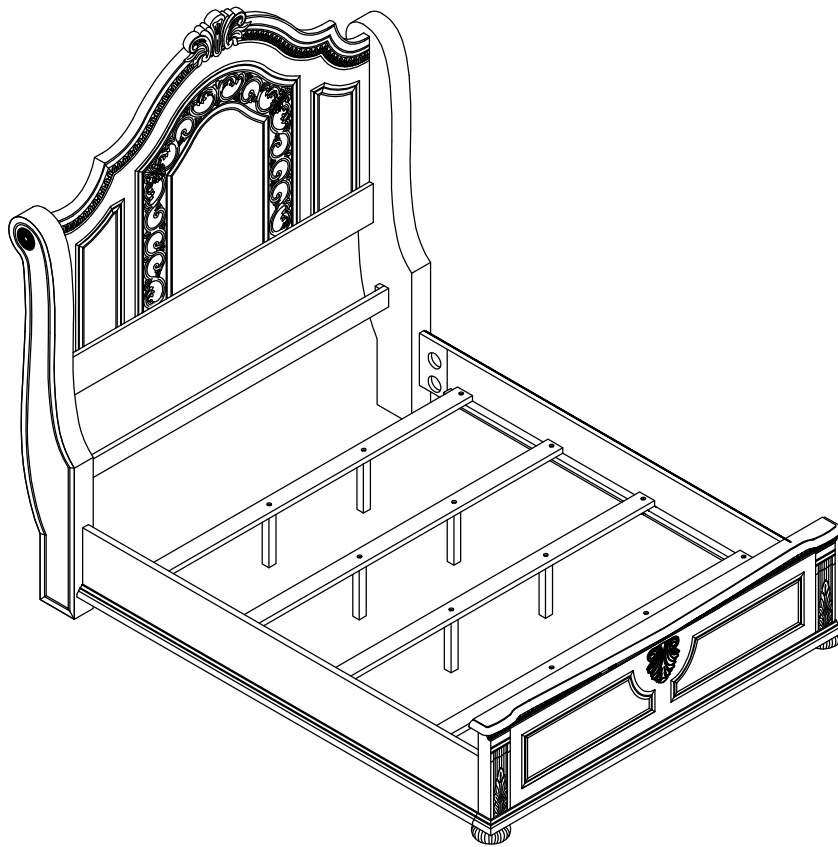

## ASSEMBLY RATING

The Assembly Rating is a 5-point system that shows the degree of effort needed in assembling a specific product (with 1 being easy and 5 being difficult). For some products, two persons are recommended.

EASY



DIFFICULT

## Tools Required For Assembly:

Allen Wrench

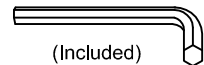

(Included)

Wrench

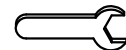

(Included)

Phillips Screwdriver



(Not Included)

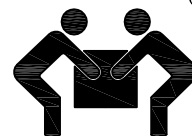

2 PERSONS RECOMMENDED

# ASSEMBLY & CARE ADVICE

FOR YOUR FURNITURE TO LAST, CORRECT ASSEMBLY AND PROPER MAINTENANCE ARE NECESSARY. PLEASE FOLLOW THE INFORMATION PROVIDED BELOW TO FULLY ENJOY YOUR FURNITURE.

## BASIC ASSEMBLY TECHNIQUES

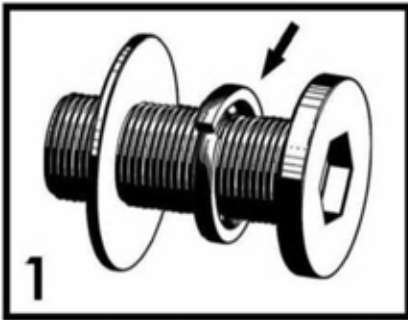

When lock or spring washer is used in an assembly, please make sure the lock or spring washer is placed between the larger flat washer and the head of the screw or bolt.



Position each part correctly and insert screws or bolts into their respective holes by hand tighten or using the proper hand tool. Only tighten when step is completed or when instructed to do so.

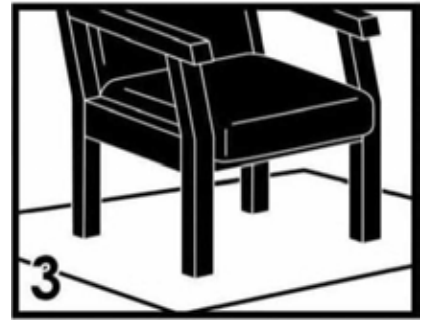

Use cardboard or carpet area when assembling furniture to prevent scratches. Make sure the furniture rests on a flat and level surface with each leg evenly touching the floor.

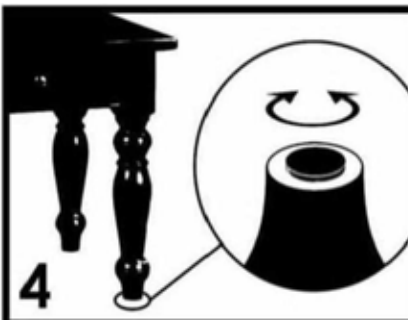

Some furniture comes with height adjustment knobs underneath each leg. To lower or to raise each leg, you need to turn clockwise or counterclockwise, respectively.

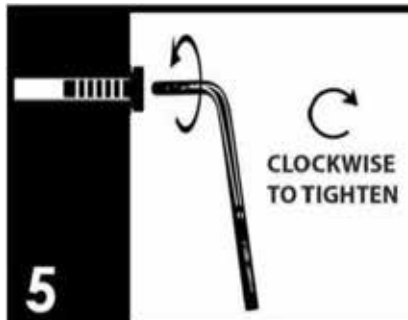

Make sure all parts are properly aligned, then use the appropriate hand tool to completely tighten the bolts or screws. Do not use power tools and do not overtighten.



Save the instructions and store the Allen wrench or any supplied tool for later maintenance. After two weeks, check and tighten any loose hardware and repeat again every six months thereafter.

IT IS THE USER'S RESPONSIBILITY TO MAINTAIN THE FURNITURE. THE HARDWARE MAY LOOSEN OVER TIME AND MAY CAUSE THE FURNITURE TO BE WOBBLY AND UNABLE TO SUPPORT ITS INTENDED WEIGHT CAPACITY. THIS MAY LEAD TO COLLAPSE AND MAY CAUSE SERIOUS INJURY.

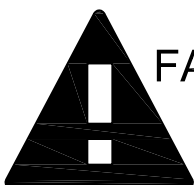





**FAILURE TO FOLLOW THE GUIDELINES ABOVE MAY RESULT IN INJURY AND/OR PROPERTY DAMAGE.**







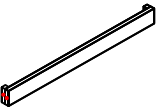
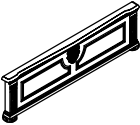
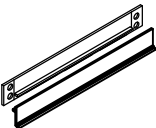
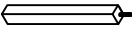

Before you begin, please read Page 2 of "Assembly and Care Advice".

And remember, do not tighten until each step is completed or instructed.

### Parts List

	#1 x 1pc Headboard Panel
	#2 x 2pcs Leg (L & R)
	#3 x 1pc Cross Bar
	#4 x 1pc Footboard
	#5 x 2pcs Bed Rail
	#6 x 8pcs Ø1/4" Support Leg 30x30x230mm
	#7 x 4pcs Bed Slat

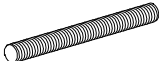
### Hardware List

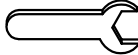
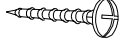
	#A x 8pcs Bolt Ø5/16" X 1-3/4"
	#B x 8pcs Spring Washer Ø5/16"
	#C x 8pcs Flat Washer Ø5/16"
	#D x 1pc Allen Wrench M4
	#E x 8pcs Thread Bolt Ø5/16"*4"
	#F x 8pcs Half Moon Ø5/16"
	#G x 8pcs Hex Nut Ø5/16"
	#H x 1pc Wrench 12mm
	#I x 8pcs Wood Screw #4x1-1/4"



1) Align leg (#2L) and crossbar (#3) to the holes of the headboard panel (#1). Prepare 4 bolts assemblies by inserting lock washer (#B), then flat washer (#C) to bolts (#A). Secure with bolts (#A) by using an Allen wrench (#D).

#A x 8pcs  
#B x 8pcs  
#C x 8pcs

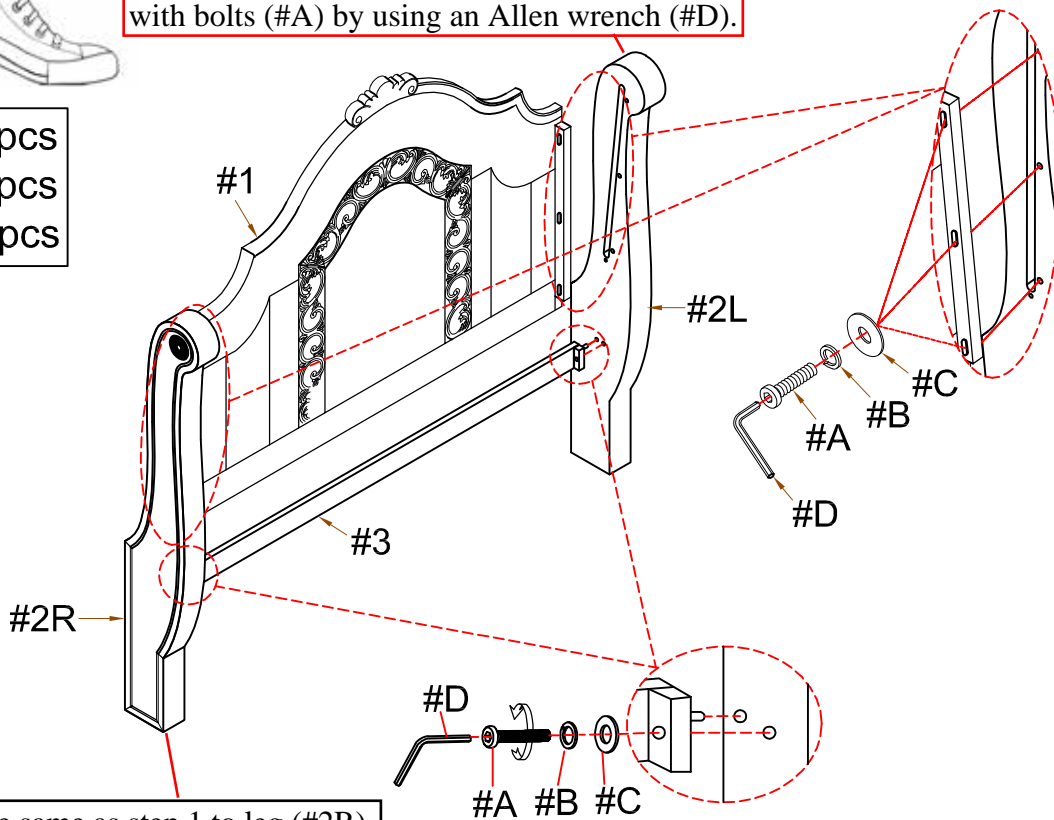

2) Do the same as step 1 to leg (#2R).



Attach thread bolts (#E) to headboard (#1) and footboard (#4). Align bed rails (#5) to headboard (#1) and footboard (#4). Secure with hex nuts (#G) by using a wrench (#H).

#E x 8pcs  
#F x 8pcs  
#G x 8pcs

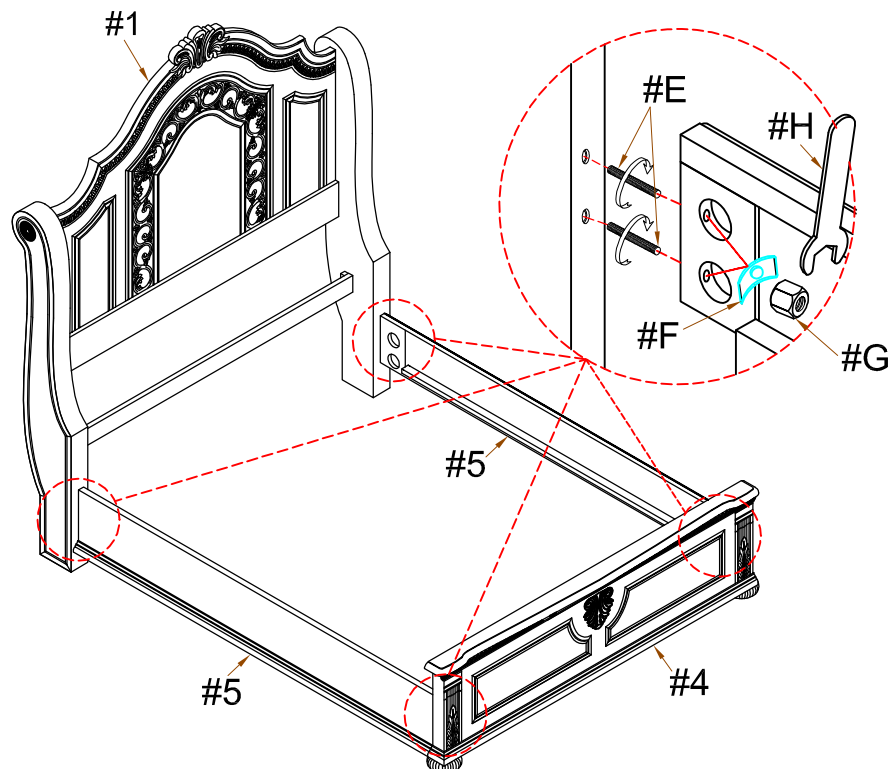

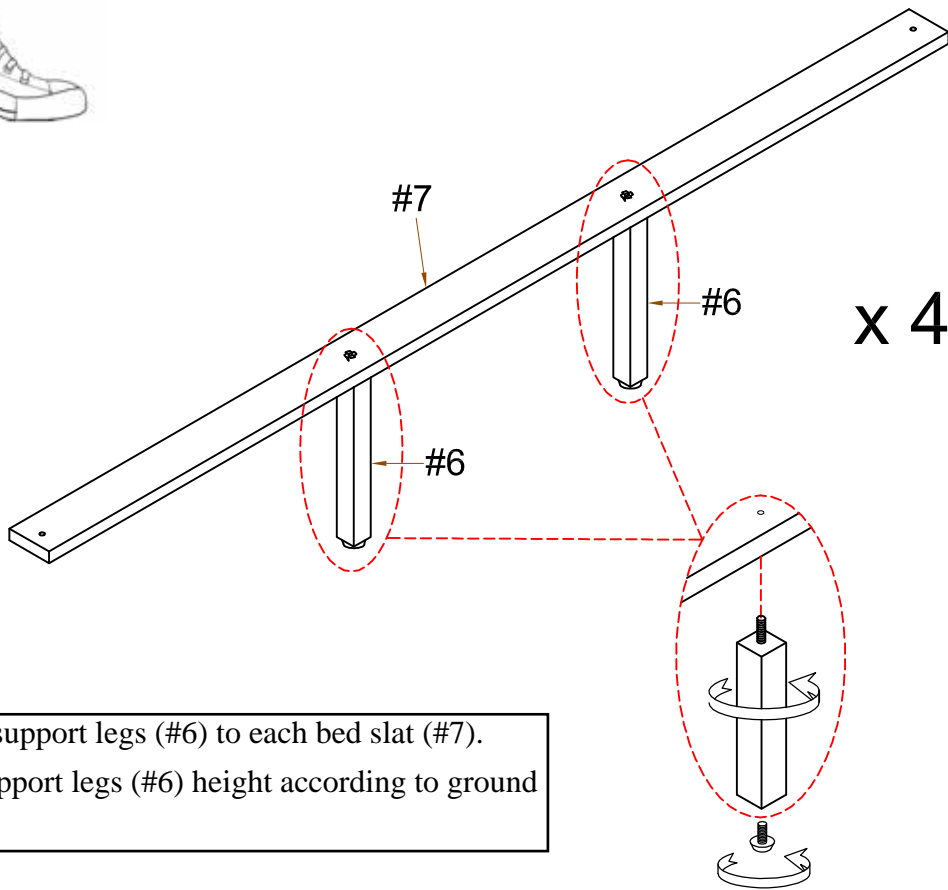

Attach 2 support legs (#6) to each bed slat (#7).  
Adjust support legs (#6) height according to ground level.



Align bed slats (#7) to the holes of the bed rails (#5).  
Secure with wood screw (#1) by using a screwdriver.

#1 x 8pcs

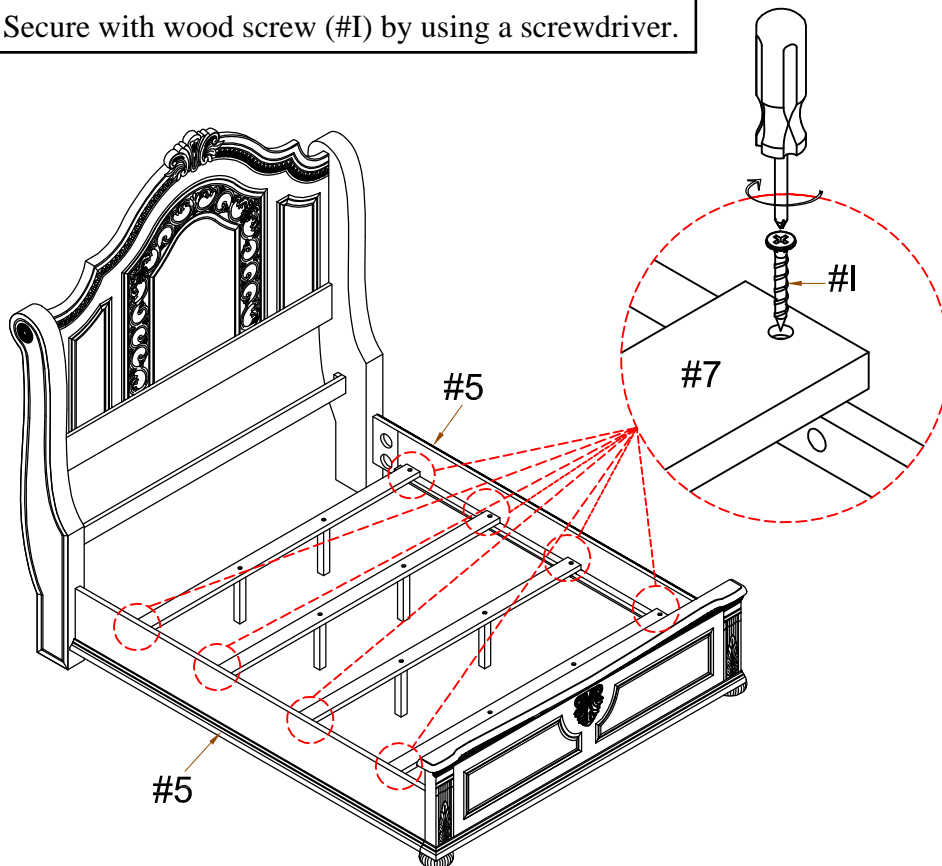

ASSEMBLY IS COMPLETED